

客户/Ciient _____

名称/TYPE Wireless charging and transmitting coil

产品型号/Model NO G42.7*2.0

本公司工程部/For Enginer Departner Only	
修改内容/Rvised Cintent	认可日期/APProved Date

编制/Prepared

审核/Checked

认可/Approved

万纪美

万纪美

刘成昭

客户认可回签/Authorixed Signaturure Company Chop		
工程/ Enginrer	认可/QC APProved	认可日期/APProved

Antenna Manufacturer:

Name: Shenzhen Ruitong Qianye Technology Co., Ltd

Address: Room 301, Building A4, Xinwei Fourth Industrial Zone, Xinzhuang Community, Matian Street, Guangming District, Shenzhen, Guangdong Province, China

一、 线圈工艺/Winding Procese:

NO	绕组	线规	匝数	绕线方向	备注
1	N1	2UEW-B-0.08*80*	10TS	CCW	
2					

二. 电气性能/FEATURES:

1.测试条件 (Test conditions) : 25°C,65%RH@100KHz/1V

1.1 电感量 (Inductance)

1.11 L0A (单独线圈) =3.6uH±20%

1.12 L0A(线圈+磁片)=6.2uH±10%

1.2 Q 值=50MIN

1.3 直流电阻 (DCR) : 80mΩ MAX

1.4 工作温度(Operating Temperature): -25°C~85°C

2.测试仪器(Test instrument): L:创达 1068+1310;DCR:502BC;SIZE:Callipers

3.材料清单

NO	项目	材料
1	WIRE	φ 0.08*80 2UEW-
2	FERRITE	42.7**0.8 L型双槽 有孔铁氧体硬磁背面双面胶
3	GLUE	水性白胶
4	SOLDER	HQ-996/JS-996
5	Tin	千岛纯锡
6	High temperature adhesive	
7		
8		

四. 外形图/OUTSIDE DIAGRA

单位: MM

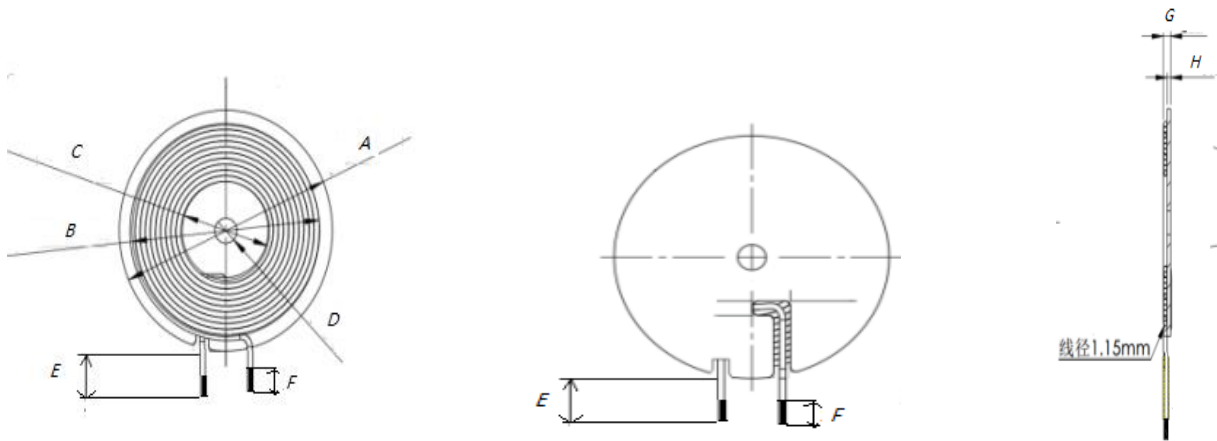

注: 线圈中心贴 20.3MM 垫子, 磁片背面贴双面背胶。

标准	A	B	C	D	E	F	G	
STD	42.7±0.3	39.5±0.3	20.5±0.5	5.3±0.5	20±2	3±1	2.0±0.2	

单位: MM

五. 包装/PACKAGE

5.1 包装图片 Packing pictures:

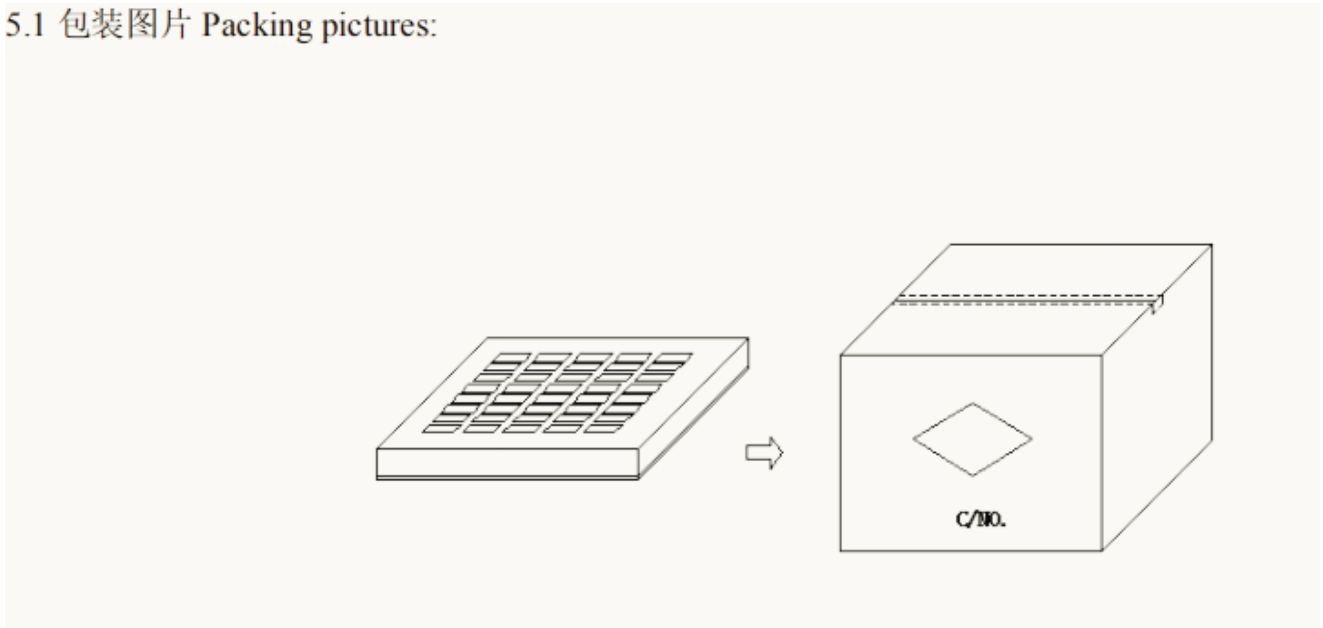

5.2 包装数量及规格 Packing Quantity:

项目 Item	数量 Quantity	材料规格 Material
盒 Box	350 Pcs	345*330*50 mm
箱 Big Carton	1750 Pcs	360*340*280 mm

5.3 包装以现有包装盘为参照标准，以实际出货包装为准，如有特殊要求可定制。

The packaging shall be based on the existing packing plate and the actual delivery package shall prevail .If there is any requirement,we can customize it.

六、贮存和使用条件 Storage and Use condition

6.1 贮存条件 Storage condition

6.1.1 建议贮存条件：温度 $-25^{\circ}\text{C} \sim 85^{\circ}\text{C}$ ，湿度 70% (Max.)

Recommended keeping conditions: $-25^{\circ}\text{C} \sim 85^{\circ}\text{C}$, 70%RH (Max.)

6.1.2 贮存期限：自生产之日起六个月内

Storage life : Within the limits of six months from being produced.

6.2 使用条件 Use condition

使用条件限制：温度 $=-25^{\circ}\text{C} \sim 85^{\circ}\text{C}$ ，湿度 $\leq 90\%$

Use condition limit: $T=-25^{\circ}\text{C} \sim 85^{\circ}\text{C}$, $\text{RH} \leq 90\%$.