

5.8 Unwanted Emission

Ambient condition

Temperature	Relative humidity	Pressure
15°C ~ 35°C	20% ~ 80%	86 kPa ~ 106 kPa

Method of Measurement

The test set-up was made in accordance to the general provisions of ANSI C63.10. The Equipment Under Test (EUT) was set up on a non-conductive table in the semi-anechoic chamber. The test was performed at the distance of 3 m between the EUT and the receiving antenna. The radiated emissions measurements were made in a typical installation configuration.

Sweep the whole frequency band through the range from 9 kHz to the 10th harmonic of the carrier, and the emissions less than 20 dB below the permissible value are reported.

During the test, below 30MHz, the center of the loop shall be 1 meters; above 30MHz, the height of receive antenna shall be moved from 1 to 4 meters, and the antenna shall be performed under horizontal and vertical polarization. The turntable shall be rotated from 0 to 360 degrees for detecting the maximum of radiated spurious signal level. The measurements shall be repeated with orthogonal polarization of the test antenna. The data of cable loss and antenna factor has been calibrated in full testing frequency range before the testing.

Set the spectrum analyzer in the following:

9kHz~150 kHz

RBW=200Hz, VBW=1kHz/ Sweep=AUTO

150 kHz~30MHz

RBW=9kHz, VBW=30kHz,/ Sweep=AUTO

Below 1GHz

RBW=100kHz / VBW=300kHz / Sweep=AUTO

Above 1GHz

(a) PEAK: RBW=1MHz VBW=3MHz/ Sweep=AUTO

(b) AVERAGE: RBW=1MHz / VBW=3MHz / Sweep=AUTO

detector; The measurements employing a CISPR quasi-peak detector except for the frequency bands 9-90 kHz, 110-490 kHz and above 1000 MHz. Radiated emission limits in these three bands are based on measurements employing an average detector.

The dwell time per channel of the hopping signal is less than 100 ms, then the reading obtained with the 10 Hz VBW may be further adjusted by a "duty cycle correction factor", derived from $20\log(\text{dwell time}/100 \text{ ms})$, in an effort to demonstrate compliance with the 15.209 limit.

If the emission is pulsed, modify the unit for continuous operation; use the settings shown above, then correct the reading by subtracting the peak- average correction factor, derived form the appropriate duty cycle calculation.

This setting method can refer to **KDB 558074 D01**.

This mode was measured in the following mode: EUT with cradle and EUT without cradle. The worst emission was found in EUT with cradle mode and the worst case was recorded.

The test is in transmitting mode.

Test setup

9kHz~ 30MHz

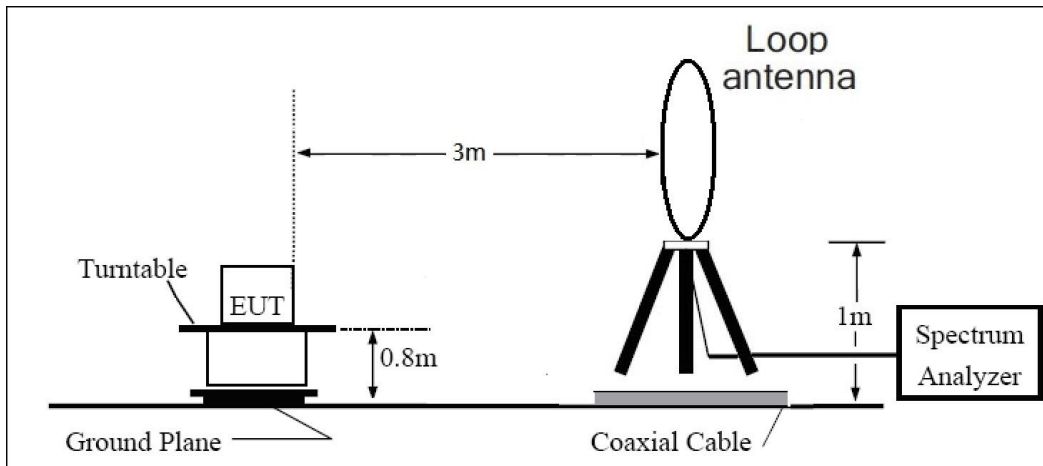

30MHz~ 1GHz

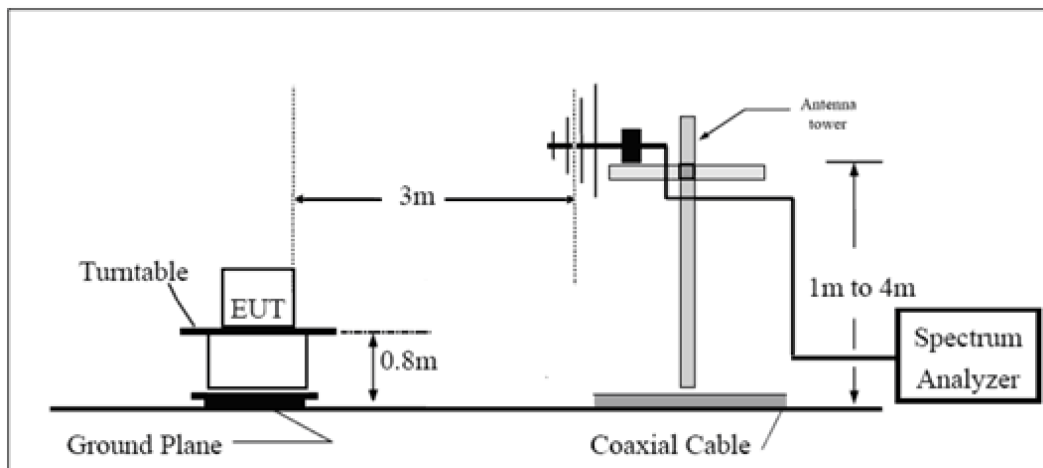

Above 1GHz

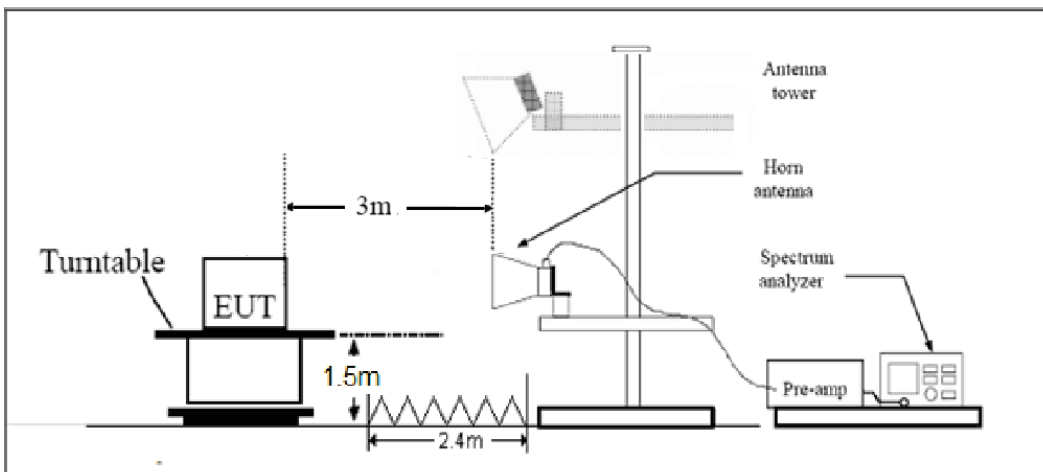

Note: Area side:2.4mX3.6m

Limits

Rule Part 15.247(d) specifies that “In addition, radiated emissions which fall in the restricted bands, as defined in § 15.205(a), must also comply with the radiated emission limits specified in § 15.209(a) (see § 15.205(c)).”

Limit in restricted band

Frequency of emission (MHz)	Field strength($\mu\text{V/m}$)	Field strength($\text{dB}\mu\text{V/m}$)
0.009–0.490	2400/F(kHz)	/
0.490–1.705	24000/F(kHz)	/
1.705–30.0	30	/
30-88	100	40
88-216	150	43.5
216-960	200	46
Above960	500	54

§15.35(b)

There is also a limit on the radio frequency emissions, as measured using instrumentation with a peak detector function, corresponding to 20 dB above the maximum permitted average limit.

Peak Limit=74dB $\mu\text{V/m}$

Average Limit=54dB $\mu\text{V/m}$

Spurious Radiated Emissions are permitted in any of the frequency bands listed below:

MHz	MHz	MHz	GHz
0.090-0.110	16.42-16.423	399.9-410	4.5-5.15
¹ 0.495-0.505	16.69475-16.69525	608-614	5.35-5.46
2.1735-2.1905	16.80425-16.80475	960-1240	7.25-7.75
4.125-4.128	25.5-25.67	1300-1427	8.025-8.5
4.17725-4.17775	37.5-38.25	1435-1626.5	9.0-9.2
4.20725-4.20775	73-74.6	1645.5-1646.5	9.3-9.5
6.215-6.218	74.8-75.2	1660-1710	10.6-12.7
6.26775-6.26825	108-121.94	1718.8-1722.2	13.25-13.4
6.31175-6.31225	123-138	2200-2300	14.47-14.5
8.291-8.294	149.9-150.05	2310-2390	15.35-16.2
8.362-8.366	156.52475-156.52525	2483.5-2500	17.7-21.4
8.37625-8.38675	156.7-156.9	2690-2900	22.01-23.12
8.41425-8.41475	162.0125-167.17	3260-3267	23.6-24.0
12.29-12.293	167.72-173.2	3332-3339	31.2-31.8
12.51975-12.52025	240-285	3345.8-3358	36.43-36.5
12.57675-12.57725	322-335.4	3600-4400	(²)
13.36-13.41			

Measurement Uncertainty

The assessed measurement uncertainty to ensure 95% confidence level for the normal distribution is with the coverage factor $k = 1.96$.

Frequency	Uncertainty
9kHz-30MHz	3.55 dB
30MHz-200MHz	4.17 dB
200MHz-1GHz	4.84 dB
1-18GHz	4.35 dB
18-26.5GHz	5.90 dB
26.5GHz~40GHz	5.92 dB

Test Results:

The following graphs display the maximum values of horizontal and vertical by software.

The signal beyond the limit is carrier.

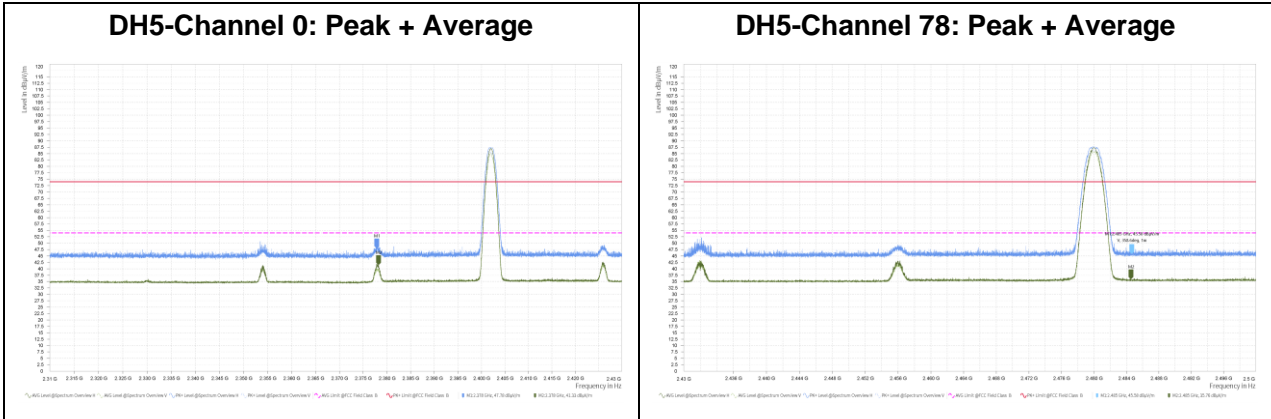

The bandage was performed in all EDR mode (2DH5 and 3DH5), 3DH5 was selected as the worse condition. The test data of the worst-case condition was recorded in this report.

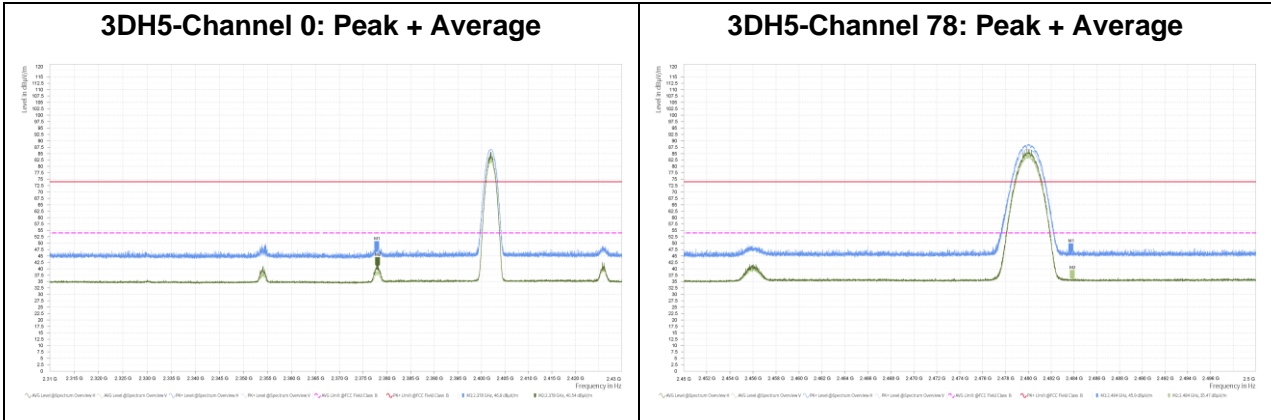

Result of RE

Test result

Sweep the whole frequency band through the range from 9kHz to the 10th harmonic of the carrier,

The following graphs display the maximum values of horizontal and vertical by software.
 For above 1GHz, Blue trace uses the peak detection, Green trace uses the average detection.

During the test, the Radiates Emission from 9kHz to 1GHz was performed in all modes with all channels, BT **GFSK Channel 0** are selected as the worst condition. The test data of the worst-case condition was recorded in this report.

A symbol ($\text{dB } \mu\text{V/m}$) in the test plot below means (dB $\mu\text{V/m}$)

Continuous TX mode:

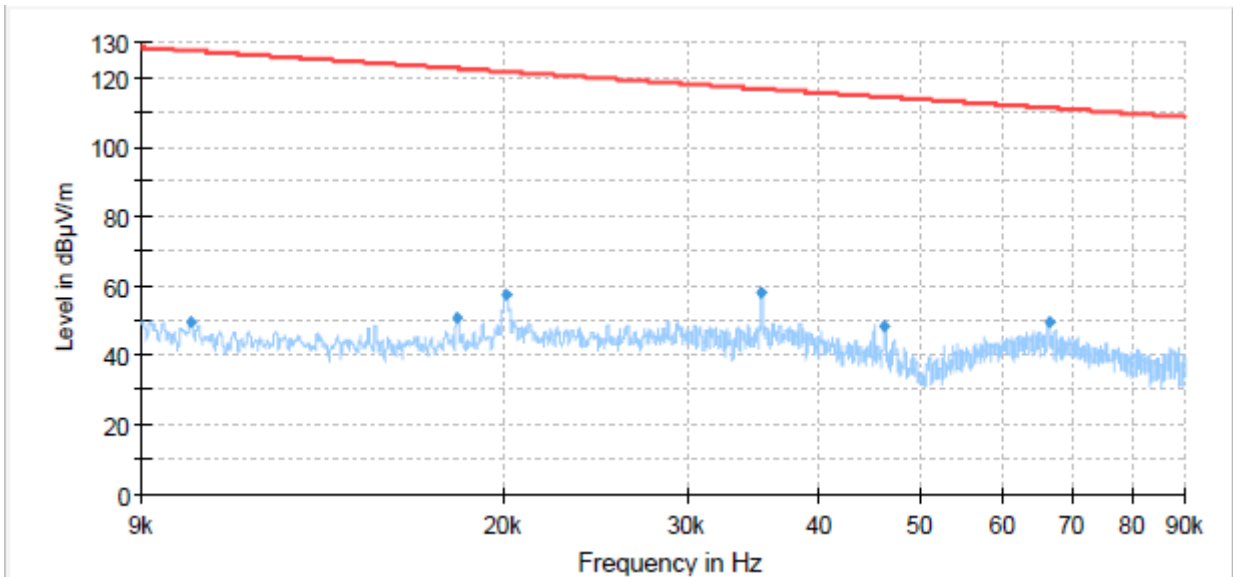

Radiates Emission from 9kHz to 90kHz

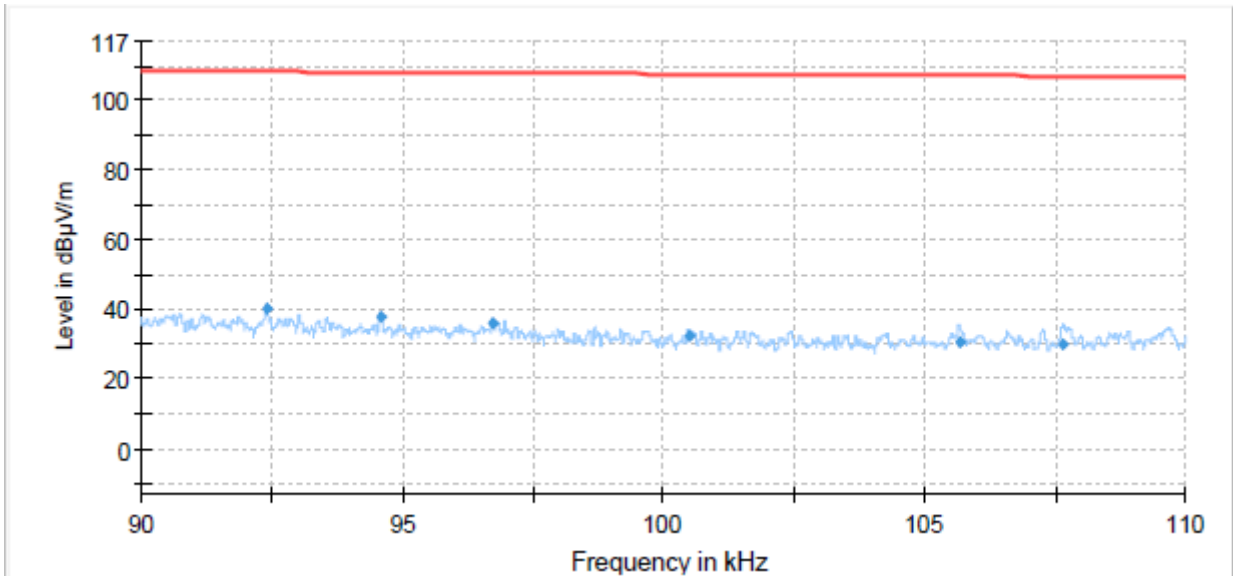

Radiates Emission from 90kHz to 110kHz

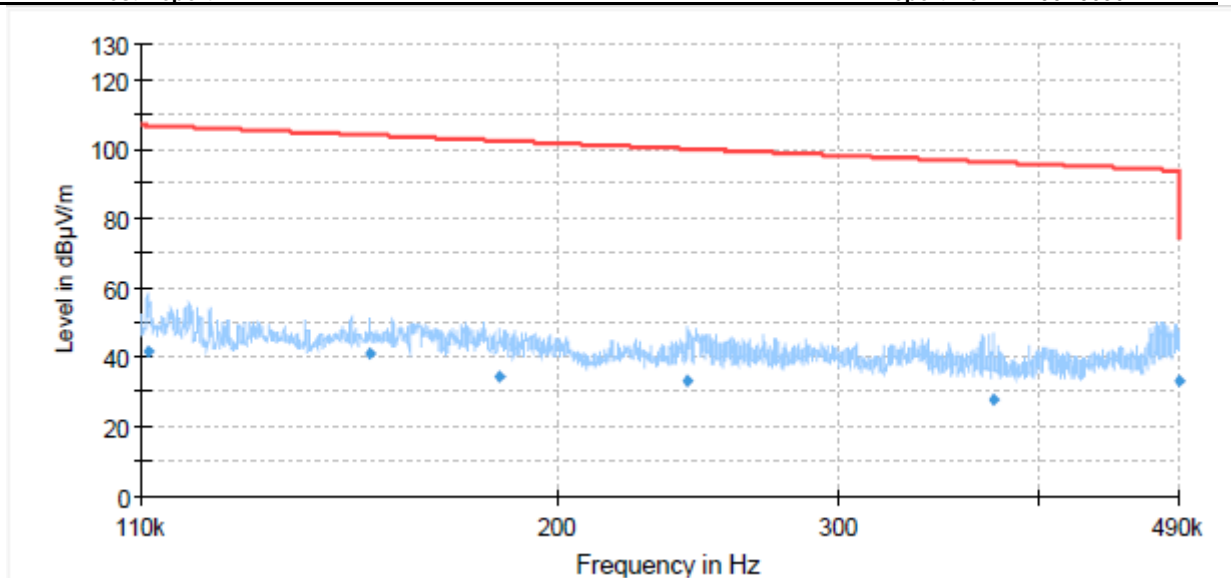

Radiates Emission from 110kHz to 490kHz

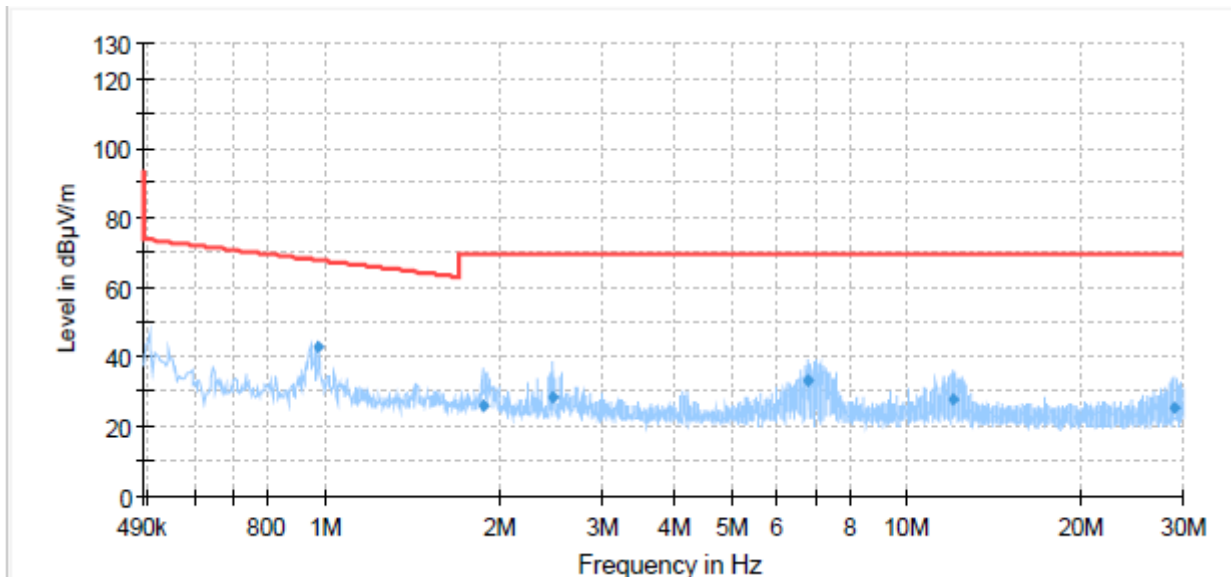

Radiates Emission from 490kHz to 30MHz

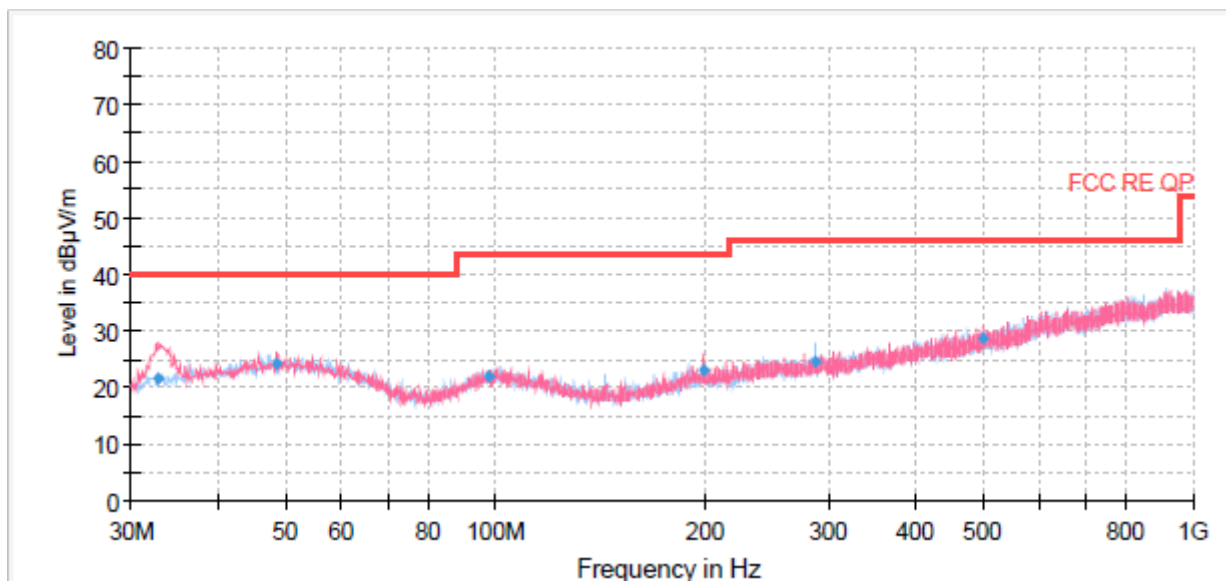

Radiates Emission from 30MHz to 1GHz

Frequency (MHz)	Quasi-Peak (dBµV/m)	Limit (dBµV/m)	Margin (dB)	Height (cm)	Polarization	Azimuth (deg)	Correct Factor (dB)
32.67	21.52	40.00	18.48	125.0	V	355.00	17
48.55	24.10	40.00	15.90	175.0	V	6.00	20
97.42	21.77	43.50	21.73	100.0	H	278.00	18
197.93	22.98	43.50	20.52	225.0	V	44.00	18
287.54	24.67	46.00	21.33	125.0	H	260.00	21
498.75	28.82	46.00	17.18	192.0	V	0.00	25

Remark: 1. Correction Factor = Antenna factor + Insertion loss (cable loss + amplifier gain)

2. Margin = Limit – Quasi-Peak

DH5-Channel 0

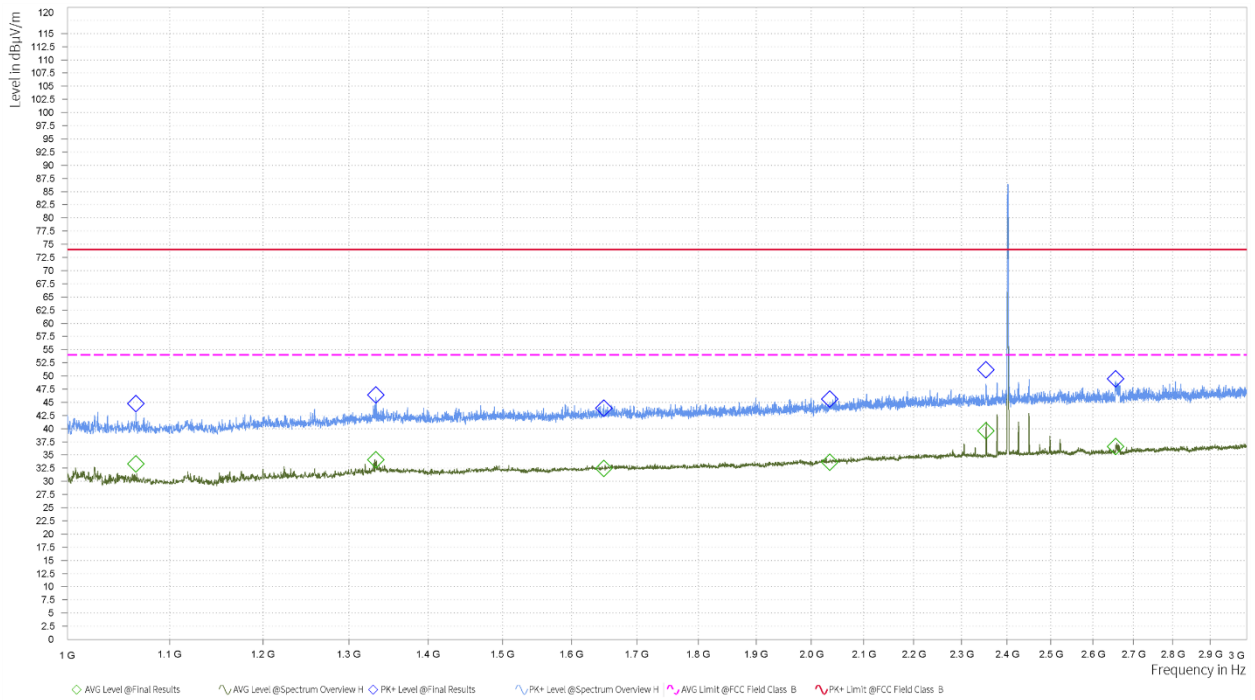

Note: The signal beyond the limit is carrier.
Radiates Emission from 1GHz to 3GHz

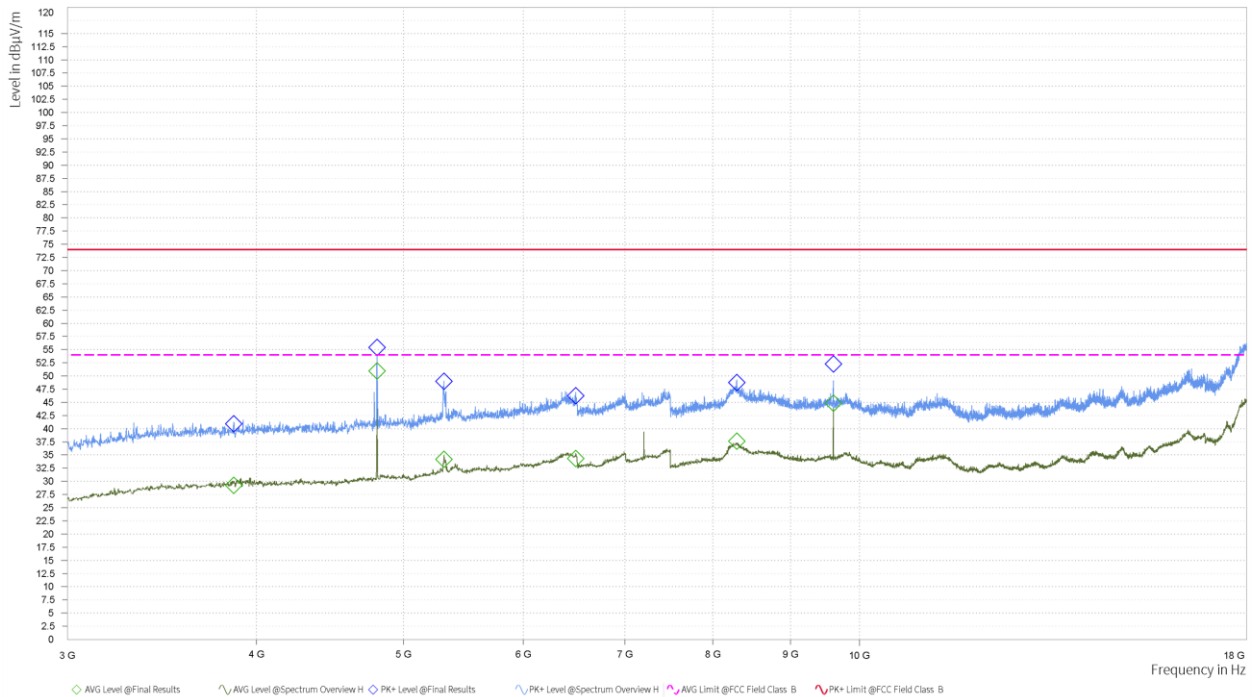

Radiates Emission from 3GHz to 18GHz

Frequency (MHz)	MaxPeak (dBμV/m)	MaxPeak Limit (dBμV/m)	MaxPeak Margin (dB)	Average (dBμV/m)	Average Limit (dBμV/m)	Average Margin (dB)	Meas. Time (ms)	Pol	Azimuth (deg)	Height (m)	Corr. (dB/m)
1,066.000	44.76	74.00	29.24	33.30	54.00	20.70	1.000	H	68.5	2.00	-6.35
1,333.250	46.41	74.00	27.59	34.09	54.00	19.91	1.000	H	51.8	2.00	-3.56
1,648.250	43.86	74.00	30.14	32.41	54.00	21.59	1.000	H	143.9	2.00	-1.37
2,035.000	45.58	74.00	28.42	33.66	54.00	20.34	1.000	H	143.9	2.00	0.86
2,353.500	51.22	74.00	22.78	39.60	54.00	14.40	1.000	H	157.3	1.00	2.17
2,655.750	49.48	74.00	24.52	36.64	54.00	17.36	1.000	H	360	2.00	3.03
9,607.500	52.27	74.00	21.73	44.83	54.00	9.17	1.000	H	268.1	1.00	4.64

Remark: 1. Correction Factor = Antenna factor + Insertion loss (cable loss + amplifier gain)

2. Margin = Limit –MAX Peak/ Average

DH5-Channel 39

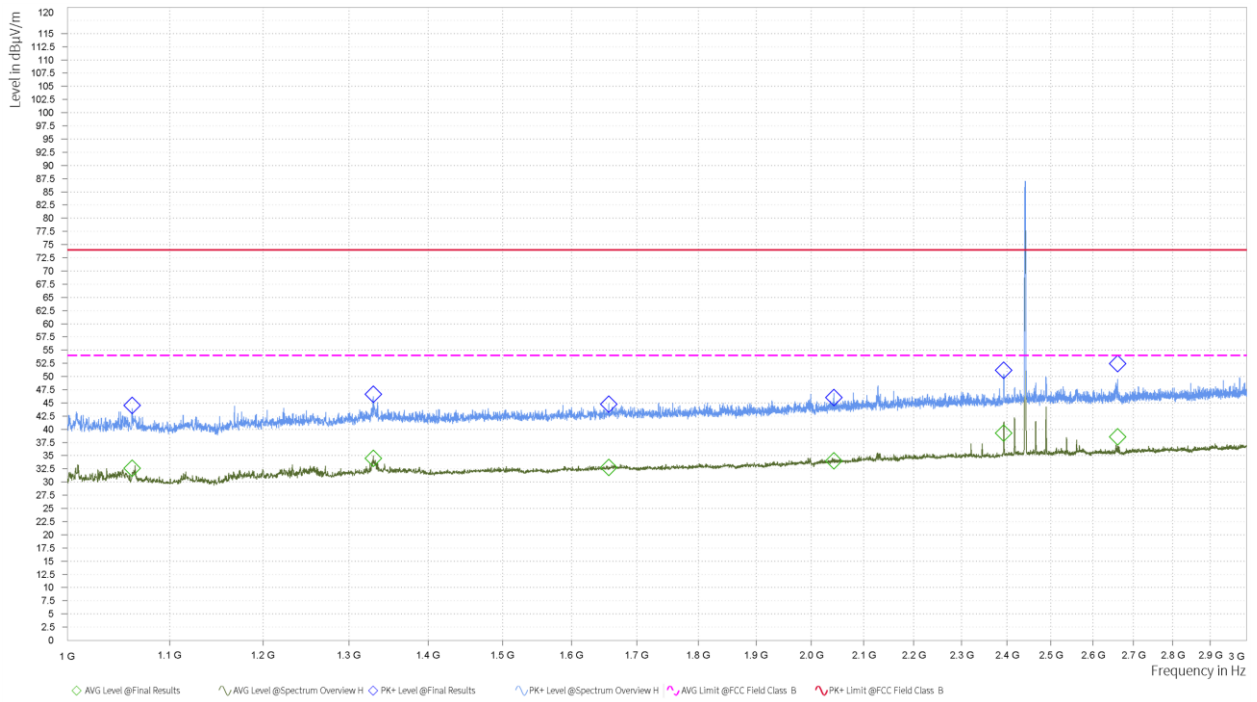

Note: The signal beyond the limit is carrier.
Radiates Emission from 1GHz to 3GHz

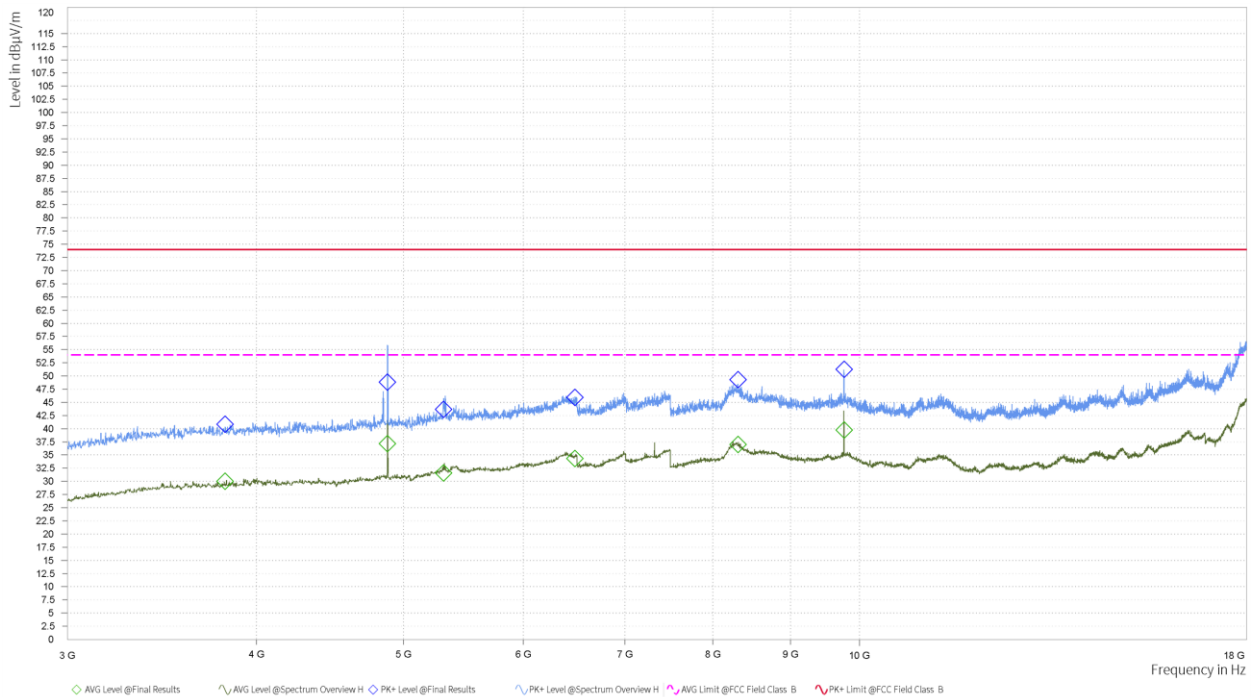

Radiates Emission from 3GHz to 18GHz

Frequency (MHz)	MaxPeak (dBμV/m)	MaxPeak Limit (dBμV/m)	MaxPeak Margin (dB)	Average (dBμV/m)	Average Limit (dBμV/m)	Average Margin (dB)	Meas. Time (ms)	Pol	Azimuth (deg)	Height (m)	Corr. (dB/m)
1,062.250	44.49	74.00	29.51	32.58	54.00	21.42	1.000	H	84.1	2.00	-6.38
1,329.750	46.61	74.00	27.39	34.51	54.00	19.49	1.000	H	21.5	1.00	-3.62
1,656.000	44.72	74.00	29.28	32.76	54.00	21.24	1.000	H	219.1	2.00	-1.21
2,042.250	46.05	74.00	27.95	34.04	54.00	19.96	1.000	H	240.1	2.00	0.95
2,392.500	51.20	74.00	22.80	39.29	54.00	14.71	1.000	H	304.1	1.00	2.48
2,660.500	52.44	74.00	21.56	38.58	54.00	15.42	1.000	H	289.9	1.00	3.04
9,765.000	51.28	74.00	22.72	39.73	54.00	14.27	1.000	H	282.8	1.00	4.81

Remark: 1. Correction Factor = Antenna factor + Insertion loss (cable loss + amplifier gain)

2. Margin = Limit –MAX Peak/ Average

DH5-Channel 78

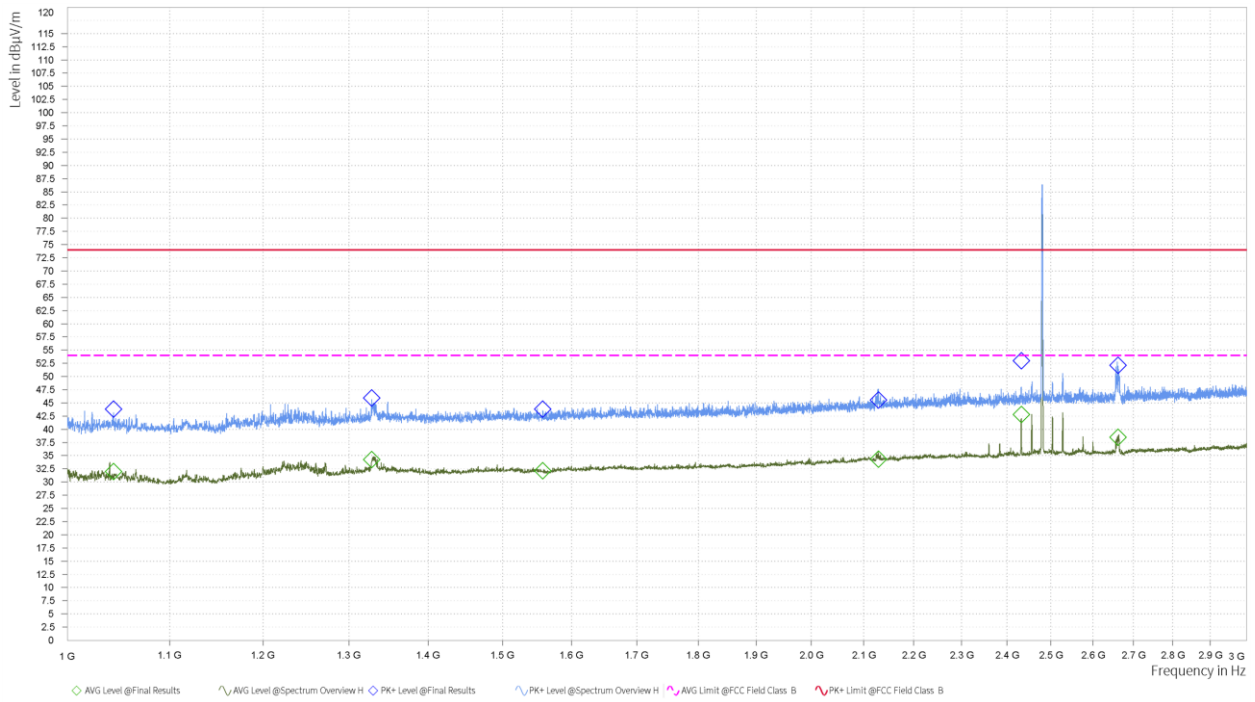

Note: The signal beyond the limit is carrier.
Radiates Emission from 1GHz to 3GHz

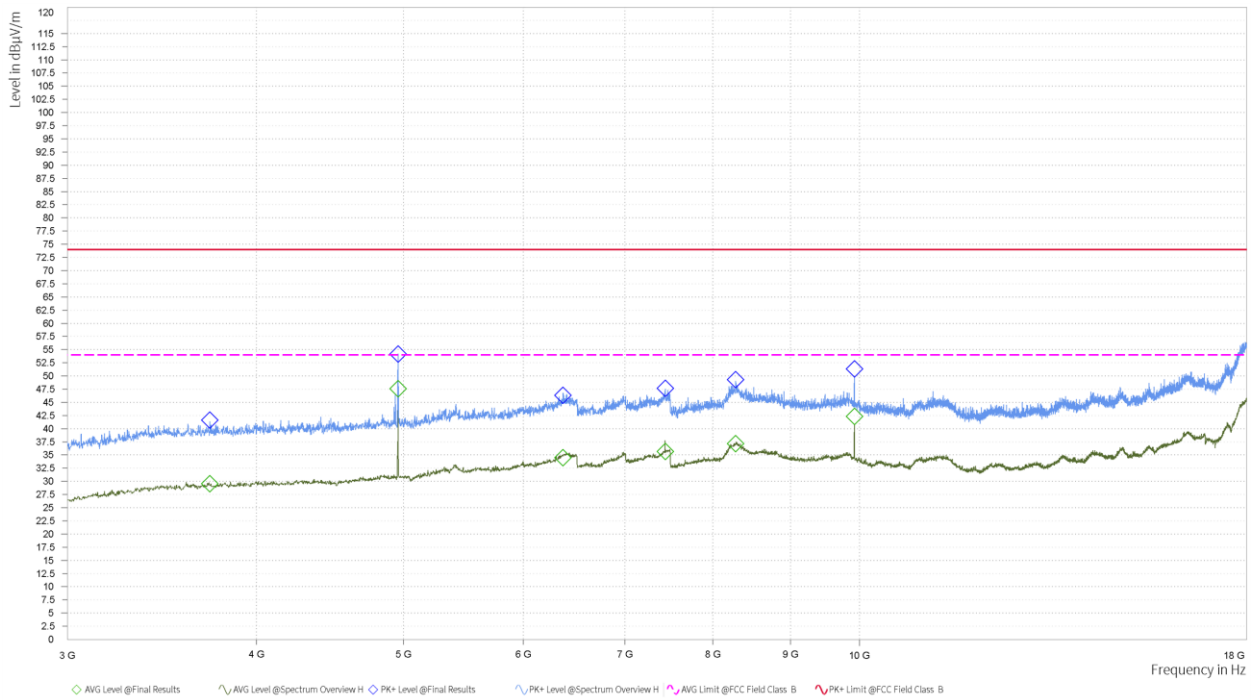

Radiates Emission from 3GHz to 18GHz

Frequency (MHz)	MaxPeak (dBμV/m)	MaxPeak Limit (dBμV/m)	MaxPeak Margin (dB)	Average (dBμV/m)	Average Limit (dBμV/m)	Average Margin (dB)	Meas. Time (ms)	Pol	Azimuth (deg)	Height (m)	Corr. (dB/m)
1,044.000	43.78	74.00	30.22	31.97	54.00	22.03	1.000	H	219.1	2.00	-6.54
1,327.750	45.90	74.00	28.10	34.29	54.00	19.71	1.000	H	346.4	1.00	-3.65
1,557.500	43.82	74.00	30.18	32.12	54.00	21.88	1.000	H	119.8	1.00	-2.17
2,129.250	45.56	74.00	28.44	34.33	54.00	19.67	1.000	H	162.5	2.00	1.34
2,432.000	53.02	74.00	20.98	42.78	54.00	11.22	1.000	H	317.8	1.00	2.54
2,662.000	52.12	74.00	21.88	38.49	54.00	15.51	1.000	H	296.5	1.00	3.05

Remark: 1. Correction Factor = Antenna factor + Insertion loss (cable loss + amplifier gain)

2. Margin = Limit –MAX Peak/ Average

The Radiates Emission was performed in all EDR mode(2DH5 and 3DH5), 3DH5 was selected as the worse condition. The test data of the worst-case condition was recorded in this report.

3DH5-Channel 0

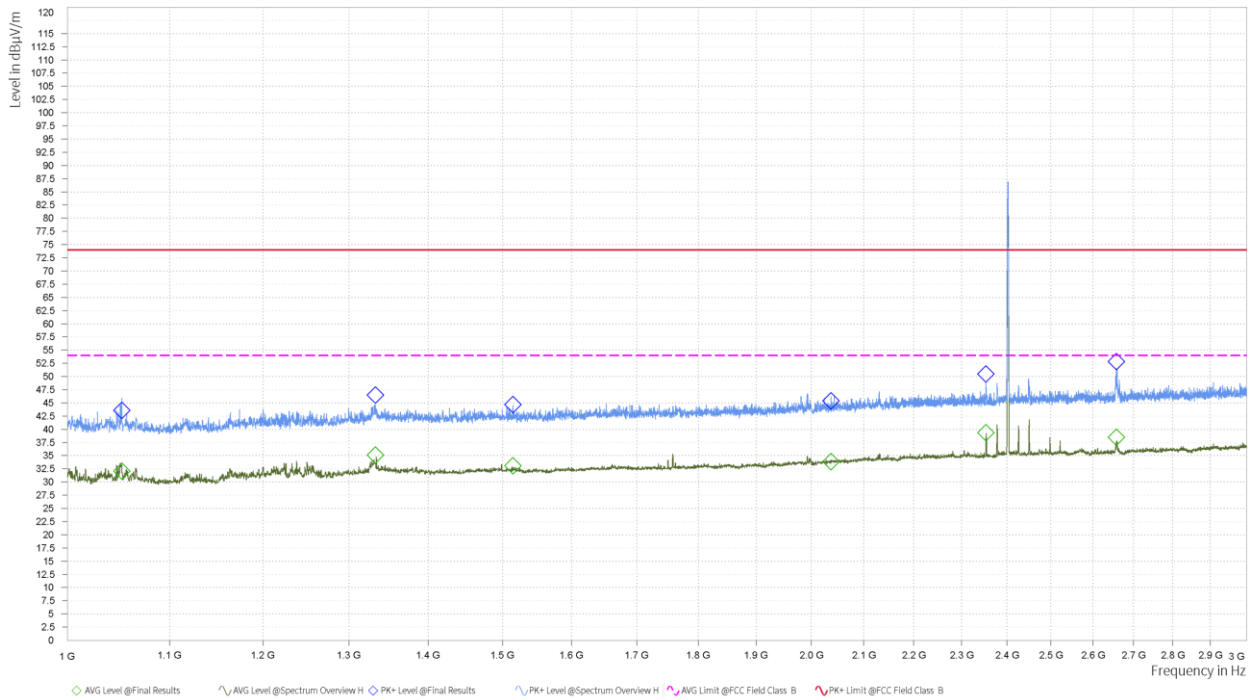

Note: The signal beyond the limit is carrier.

Radiates Emission from 1GHz to 3GHz

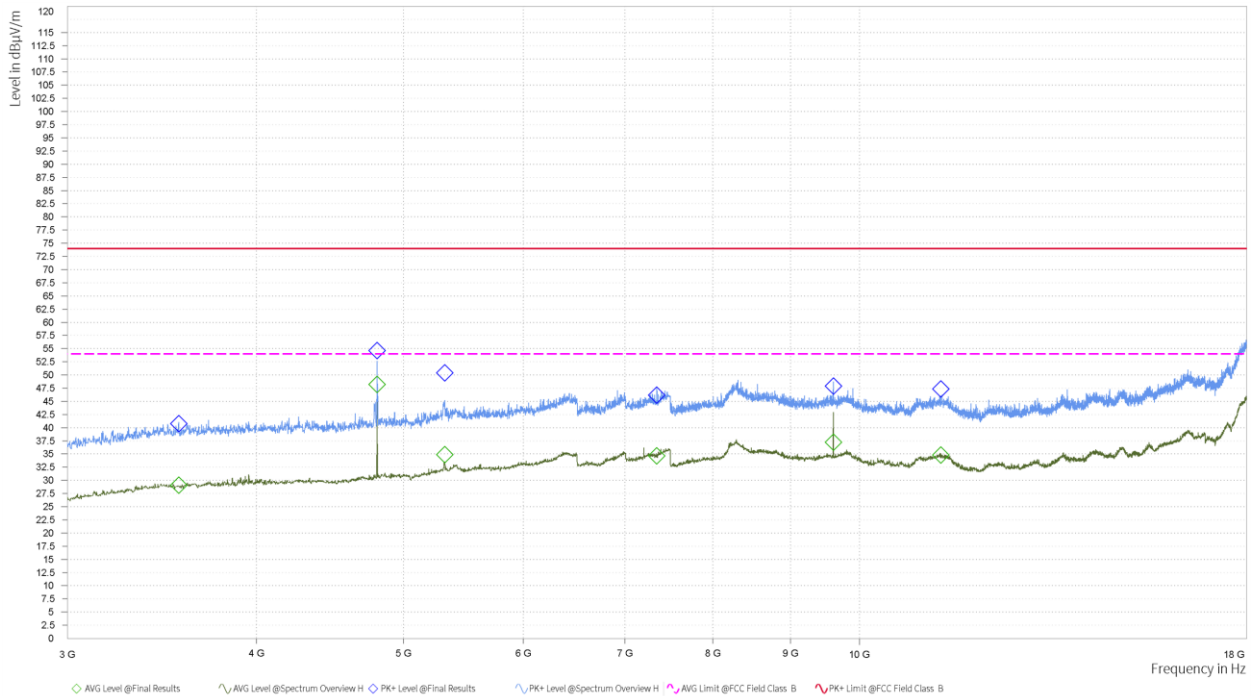

Radiates Emission from 3GHz to 18GHz

Frequency (MHz)	MaxPeak (dBμV/m)	MaxPeak Limit (dBμV/m)	MaxPeak Margin (dB)	Average (dBμV/m)	Average Limit (dBμV/m)	Average Margin (dB)	Meas. Time (ms)	Pol	Azimuth (deg)	Height (m)	Corr. (dB/m)
1,052.000	43.54	74.00	30.46	32.08	54.00	21.92	1.000	H	288.5	2.00	-6.48
1,332.500	46.48	74.00	27.52	35.15	54.00	18.85	1.000	H	337.9	2.00	-3.57
1,514.500	44.72	74.00	29.28	33.05	54.00	20.95	1.000	H	97.9	1.00	-2.35
2,037.250	45.36	74.00	28.64	33.89	54.00	20.11	1.000	H	224.8	2.00	0.89
2,353.500	50.46	74.00	23.54	39.31	54.00	14.69	1.000	H	147.4	1.00	2.17
2,657.250	52.83	74.00	21.17	38.46	54.00	15.54	1.000	H	288.8	1.00	3.04

Remark: 1. Correction Factor = Antenna factor + Insertion loss (cable loss + amplifier gain)

2. Margin = Limit –MAX Peak/ Average

3DH5-Channel 39

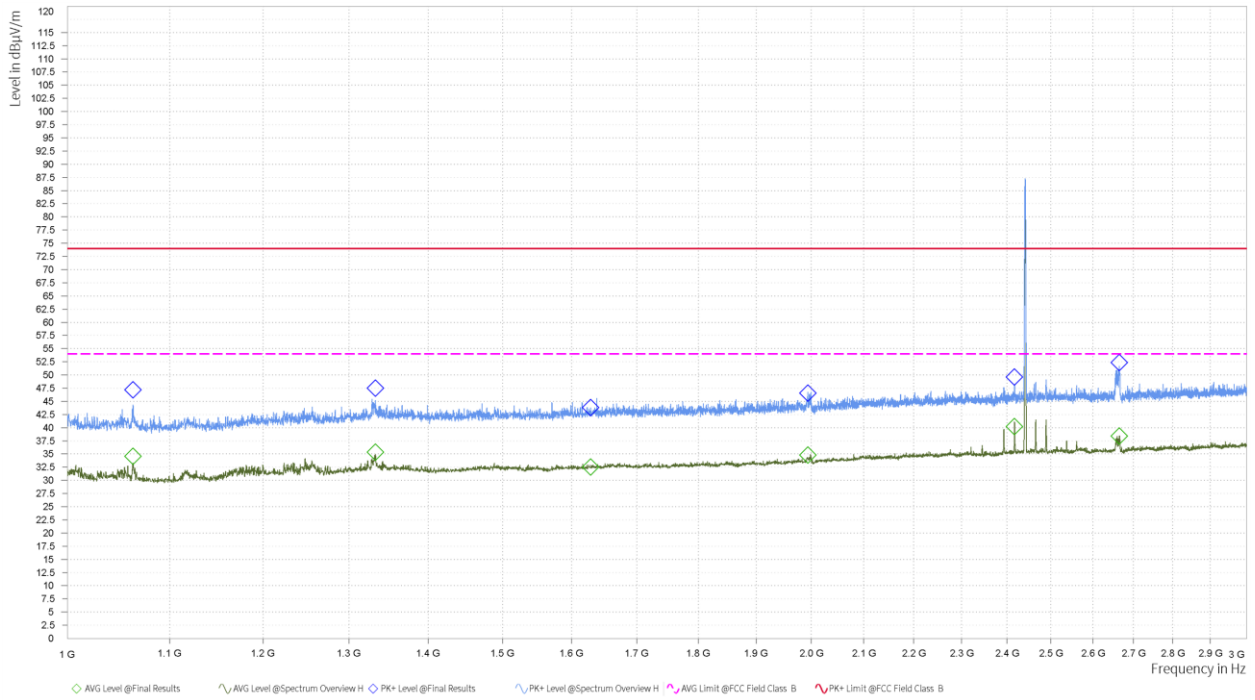

Note: The signal beyond the limit is carrier.
Radiates Emission from 1GHz to 3GHz

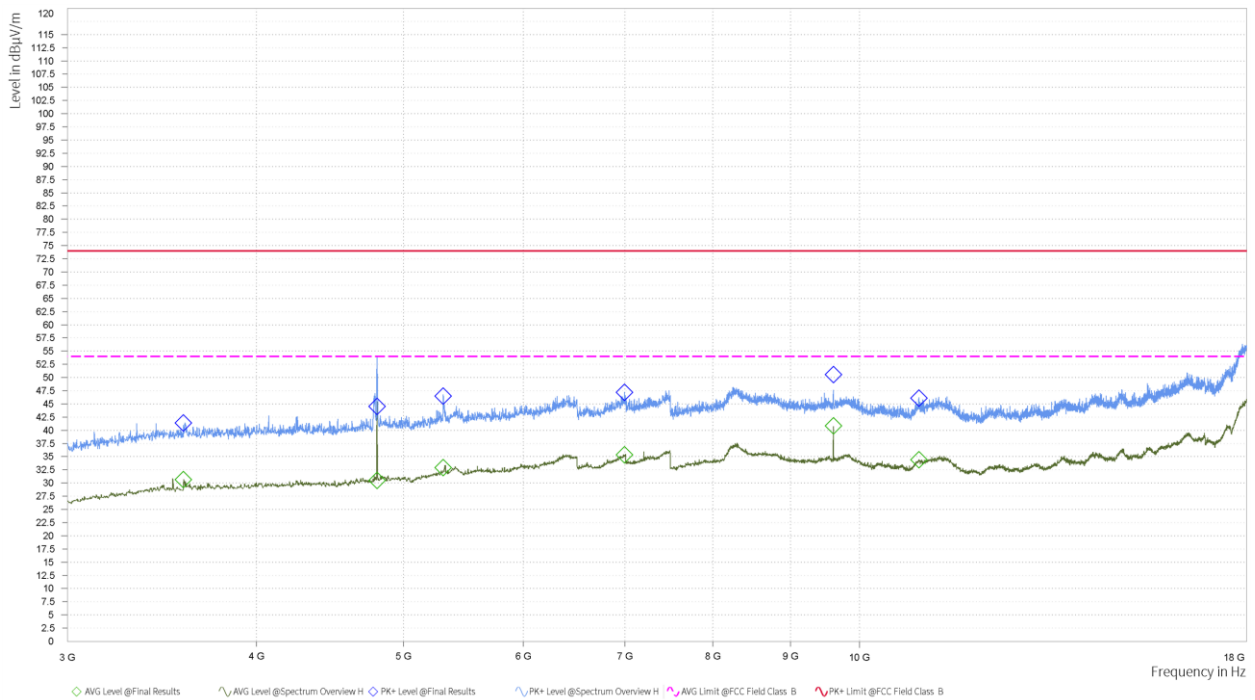

Radiates Emission from 3GHz to 18GHz

Frequency (MHz)	MaxPeak (dBμV/m)	MaxPeak Limit (dBμV/m)	MaxPeak Margin (dB)	Average (dBμV/m)	Average Limit (dBμV/m)	Average Margin (dB)	Meas. Time (ms)	Pol	Azimuth (deg)	Height (m)	Corr. (dB/m)
1,063.250	47.22	74.00	26.78	34.56	54.00	19.44	1.000	H	224.4	1.00	-6.37
1,332.500	47.49	74.00	26.51	35.37	54.00	18.63	1.000	H	66.9	1.00	-3.57
1,628.500	43.79	74.00	30.21	32.49	54.00	21.51	1.000	H	295.5	2.00	-1.52
1,993.750	46.55	74.00	27.45	34.79	54.00	19.21	1.000	H	93.6	2.00	0.52
2,417.000	49.62	74.00	24.38	40.23	54.00	13.77	1.000	H	295.5	2.00	2.53
2,664.250	52.33	74.00	21.67	38.44	54.00	15.56	1.000	H	295.9	1.00	3.05
9,607.500	50.55	74.00	23.45	40.84	54.00	13.16	1.000	H	268.8	2.00	4.64

Remark: 1. Correction Factor = Antenna factor + Insertion loss (cable loss + amplifier gain)

2. Margin = Limit –MAX Peak/ Average

3DH5-Channel 78

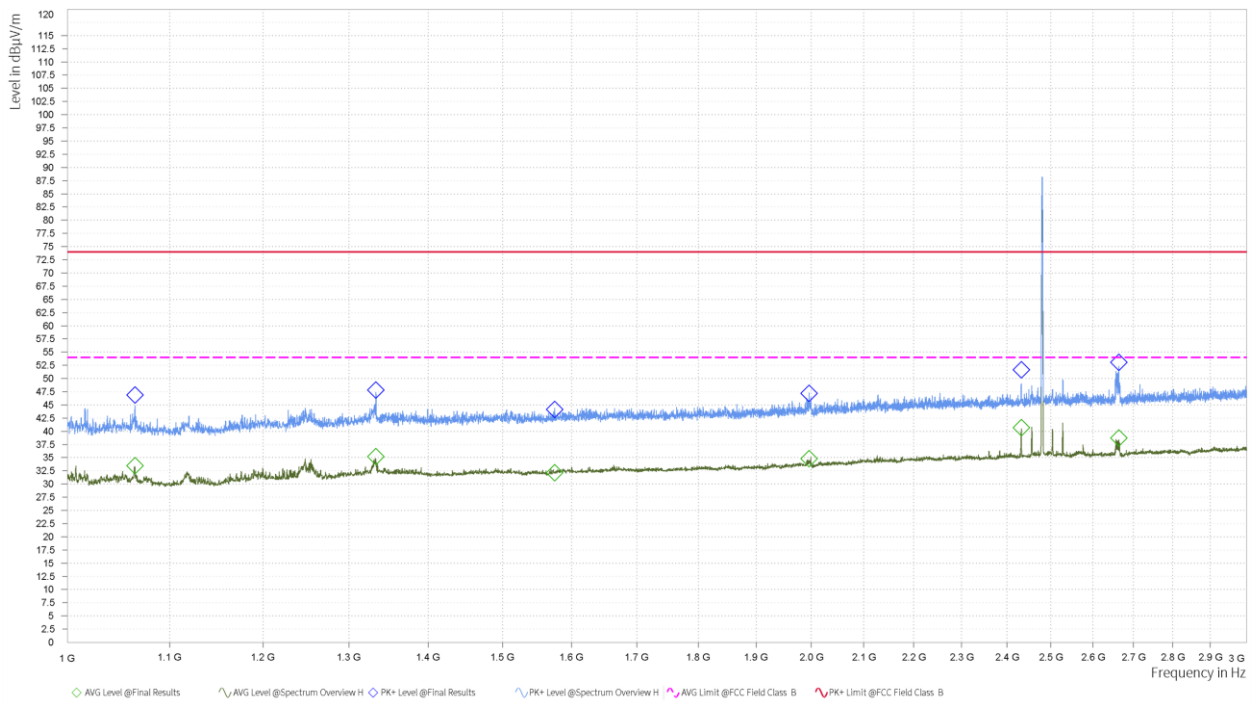

Note: The signal beyond the limit is carrier.
Radiates Emission from 1GHz to 3GHz

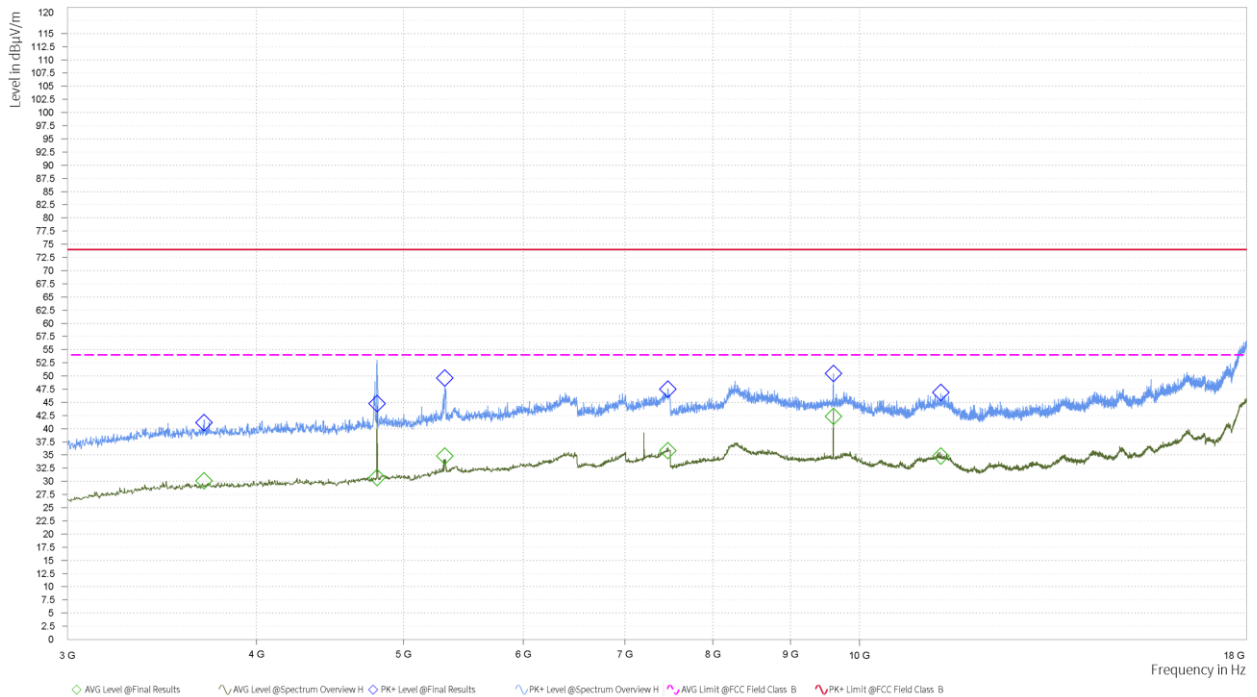

Radiates Emission from 3GHz to 18GHz

Frequency (MHz)	MaxPeak (dBμV/m)	MaxPeak Limit (dBμV/m)	MaxPeak Margin (dB)	Average (dBμV/m)	Average Limit (dBμV/m)	Average Margin (dB)	Meas. Time (ms)	Pol	Azimuth (deg)	Height (m)	Corr. (dB/m)
1,065.000	46.87	74.00	27.13	33.51	54.00	20.49	1.000	H	214.7	2.00	-6.36
1,333.250	47.85	74.00	26.15	35.17	54.00	18.83	1.000	H	51.9	1.00	-3.56
1,574.500	44.10	74.00	29.90	32.16	54.00	21.84	1.000	H	351.3	2.00	-1.93
1,995.750	47.18	74.00	26.82	34.78	54.00	19.22	1.000	H	73.5	1.00	0.50
2,432.000	51.66	74.00	22.34	40.67	54.00	13.33	1.000	H	300.2	2.00	2.54
2,663.500	53.07	74.00	20.93	38.73	54.00	15.27	1.000	H	295.1	1.00	3.05
9,607.500	50.45	74.00	23.55	42.29	54.00	11.71	1.000	H	268.4	1.00	4.64

Remark: 1. Correction Factor = Antenna factor + Insertion loss (cable loss + amplifier gain)

2. Margin = Limit –MAX Peak/ Average

During the test, the Radiates Emission from 18GHz to 26.5GHz was performed in all modes with all channels, DH5-Channel 0 are selected as the worst condition. The test data of the worst-case condition was recorded in this report.

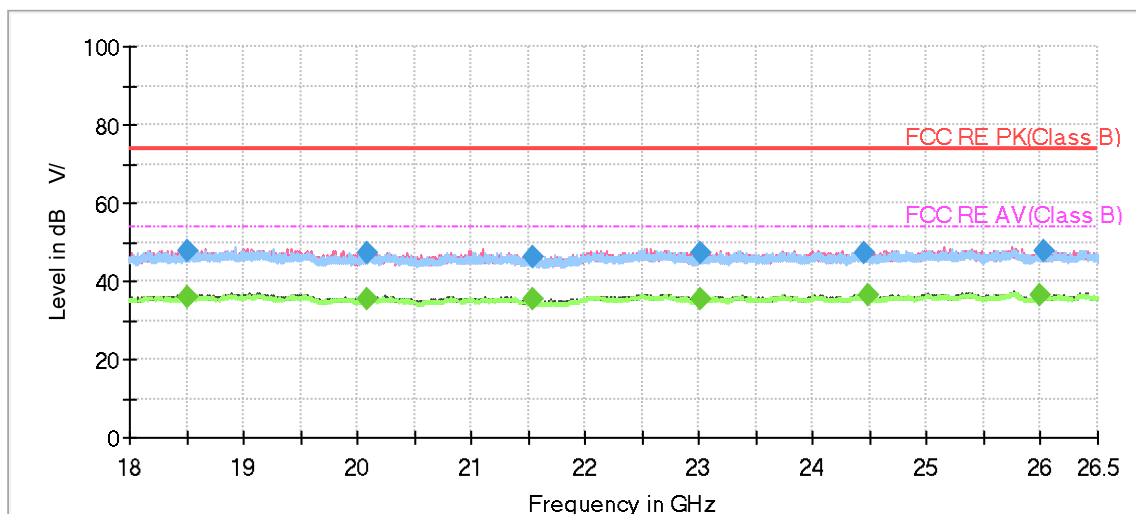

Radiates Emission from 18GHz to 26.5GHz

Frequency (MHz)	MaxPeak (dB μ V/m)	Average (dB μ V/m)	Limit (dB μ V/m)	Margin (dB)	Meas. Time (ms)	Height (cm)	Pol	Azimuth (deg)	Corr. (dB/m)
18503.625000	---	36.01	54.00	17.99	500.0	100.0	V	150.0	-4.6
18514.250000	47.79	---	74.00	26.21	500.0	200.0	H	34.0	-4.6
20084.625000	---	35.59	54.00	18.41	500.0	200.0	V	122.0	-4.5
20093.125000	47.20	---	74.00	26.80	500.0	200.0	V	180.0	-4.5
21539.187500	---	35.32	54.00	18.68	500.0	100.0	V	72.0	-4.1
21545.562500	46.37	---	74.00	27.63	500.0	100.0	V	30.0	-4.1
23010.750000	47.36	---	74.00	26.64	500.0	100.0	V	90.0	-3.0
23019.250000	---	35.51	54.00	18.49	500.0	100.0	V	85.0	-3.0
24445.125000	47.34	---	74.00	26.66	500.0	200.0	V	157.0	-2.3
24492.937500	---	36.25	54.00	17.75	500.0	100.0	V	169.0	-2.3
25994.250000	---	36.47	54.00	17.53	500.0	100.0	V	0.0	-1.4
26033.562500	47.91	---	74.00	26.09	500.0	200.0	H	85.0	-1.4

Remark: 1. Correction Factor = Antenna factor + Insertion loss (cable loss + amplifier gain)

2. Margin = Limit - MAX Peak/ Average

5.9 Conducted Emission

Ambient condition

Temperature	Relative humidity	Pressure
15°C ~ 35°C	20% ~ 80%	86 kPa ~ 106 kPa

Methods of Measurement

The EUT is placed on a non-metallic table of 80cm height above the horizontal metal reference ground plane. During the test, the EUT was operating in its typical mode. The test method is according to ANSI C63.10. Connect the AC power line of the EUT to the L.I.S.N. Use EMI receiver to detect the average and Quasi-peak value. RBW is set to 9 kHz, VBW is set to 30kHz. The measurement result should include both L line and N line.

The test is in transmitting mode.

Test Setup

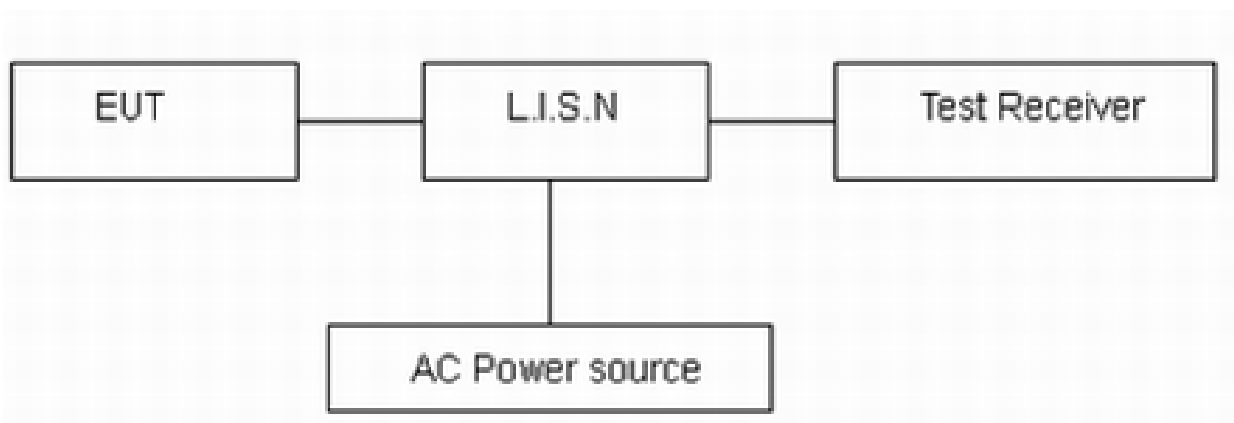

Note: AC Power source is used to 120V/60Hz.

Limits

Frequency (MHz)	Conducted Limits(dBμV)	
	Quasi-peak	Average
0.15 - 0.5	66 to 56 *	56 to 46*
0.5 - 5	56	46
5 - 30	60	50

*: Decreases with the logarithm of the frequency.

Measurement Uncertainty

The assessed measurement uncertainty to ensure 95% confidence level for the normal distribution is with the coverage factor $k = 1.96$, $U=2.69$ dB.

Test Results:

Following plots, Blue trace uses the peak detection, Green trace uses the average detection. During the test, the Conducted Emission was performed in all modes with all channels, BT **DH5 channel 0**, are selected as the worst condition. The test data of the worst-case condition was recorded in this report.

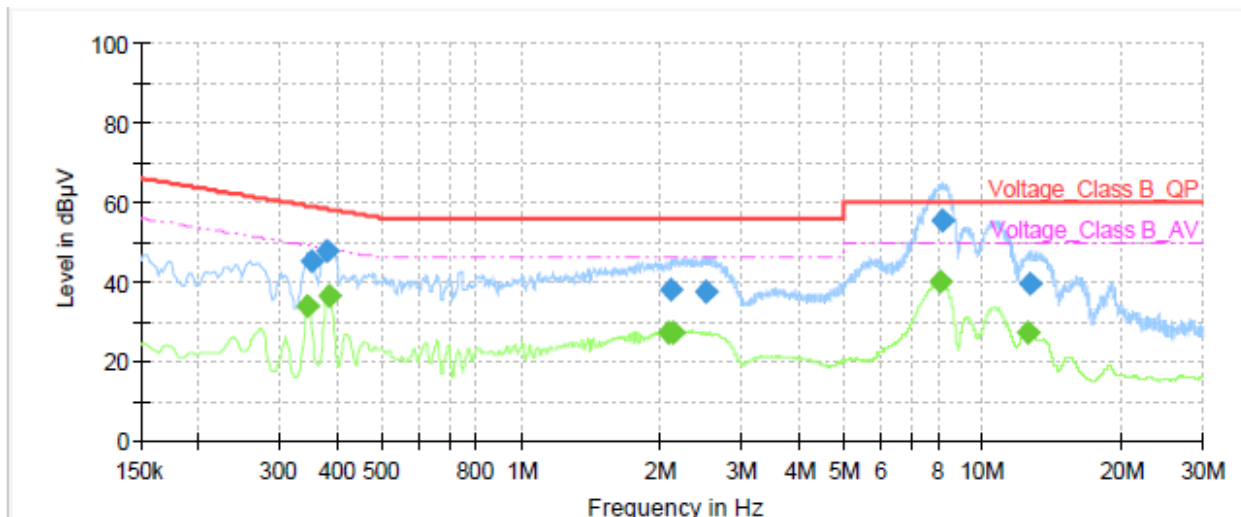

Frequency (MHz)	QuasiPeak (dBµV)	Average (dBµV)	Limit (dBµV)	Margin (dB)	Meas. Time (ms)	Bandwidth (kHz)	Line	Filter	Corr. (dB)
0.35	---	33.84	49.06	15.22	1000.0	9.000	L1	ON	21.0
0.35	45.12	---	58.96	13.84	1000.0	9.000	L1	ON	21.0
0.38	47.62	---	58.29	10.67	1000.0	9.000	L1	ON	21.0
0.38	---	36.46	48.24	11.78	1000.0	9.000	L1	ON	21.0
2.09	---	27.06	46.00	18.94	1000.0	9.000	L1	ON	19.7
2.10	38.11	---	56.00	17.89	1000.0	9.000	L1	ON	19.7
2.13	---	27.08	46.00	18.92	1000.0	9.000	L1	ON	19.7
2.53	37.63	---	56.00	18.37	1000.0	9.000	L1	ON	19.6
8.12	---	39.83	50.00	10.17	1000.0	9.000	L1	ON	19.5
8.20	55.49	---	60.00	4.51	1000.0	9.000	L1	ON	19.5
12.58	---	27.08	50.00	22.92	1000.0	9.000	L1	ON	19.6
12.71	39.69	---	60.00	20.31	1000.0	9.000	L1	ON	19.6

Remark: Correct factor=cable loss + LISN factor

L line

Conducted Emission from 150 kHz to 30 MHz

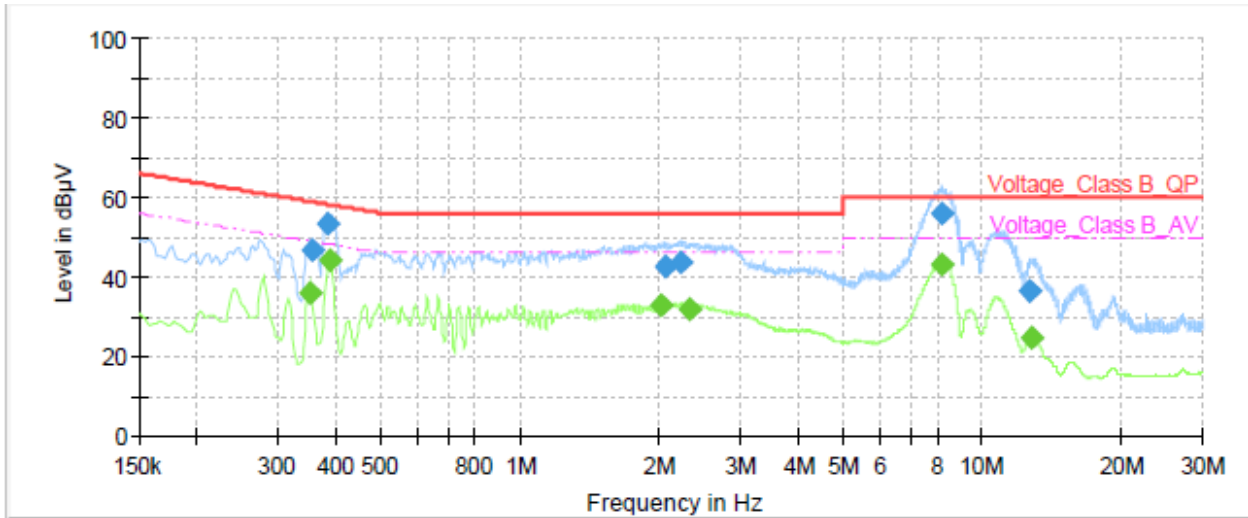

Frequency (MHz)	QuasiPeak (dBµV)	Average (dBµV)	Limit (dBµV)	Margin (dB)	Meas. Time (ms)	Bandwidth (kHz)	Line	Filter	Corr. (dB)
0.35	---	35.83	48.96	13.13	1000.0	9.000	N	ON	21.0
0.36	46.43	---	58.80	12.37	1000.0	9.000	N	ON	21.0
0.38	53.26	---	58.19	4.93	1000.0	9.000	N	ON	21.0
0.39	---	44.05	48.14	4.09	1000.0	9.000	N	ON	21.0
2.02	---	32.59	46.00	13.41	1000.0	9.000	N	ON	19.7
2.07	42.81	---	56.00	13.19	1000.0	9.000	N	ON	19.7
2.23	43.58	---	56.00	12.42	1000.0	9.000	N	ON	19.7
2.33	---	31.87	46.00	14.13	1000.0	9.000	N	ON	19.6
8.14	56.04	---	60.00	3.96	1000.0	9.000	N	ON	19.5
8.18	---	43.28	50.00	6.72	1000.0	9.000	N	ON	19.5
12.71	36.24	---	60.00	23.76	1000.0	9.000	N	ON	19.6
12.86	---	24.56	50.00	25.44	1000.0	9.000	N	ON	19.6

Remark: Correct factor=cable loss + LISN factor

N line Conducted Emission from 150 kHz to 30 MHz

6 Main Test Instruments

Name	Manufacturer	Type	Serial Number	Calibration Date	Expiration Date
Power sensor	R&S	NRP18S	101954	2024-05-07	2025-05-06
Spectrum Analyzer	KEYSIGHT	N9020A	MY51330870	2024-05-07	2025-05-06
Unwanted Emission					
EMI Test Receiver	R&S	ESCI3	100948	2024-05-07	2025-05-06
EMI Test Receiver	R&S	ESR	102720	2024-05-07	2025-05-06
EMI Test Receiver	R&S	ESR	102721	2024-05-07	2025-05-06
Loop Antenna	SCHWARZBECK	FMZB1519	1519-047	2023-04-16	2026-04-15
Horn Antenna	ETS-Lindgren	3160-09	00102643	2021-10-10	2024-10-09
Amplifier	MicroWave	KLNA-18040 050	220826001	2024-05-08	2025-05-07
TRILOG Broadband Antenna	SCHWARZBECK	VULB 9163	01614	2023-09-13	2026-09-12
TRILOG Broadband Antenna	SCHWARZBECK	VULB 9163	01615	2023-10-19	2026-10-18
Horn Antenna	R&S	BBHA9170	01301	2023-09-19	2026-09-18
Software	R&S	EMC32	9.26.01	/	/
Software	R&S	ELEKTRA	5.00.2	/	/
Conducted Emission					
Artificial main network	R&S	ENV216	102191	2022-12-10	2024-12-09
EMI Test Receiver	R&S	ESR	101667	2024-05-07	2025-05-06
Software	R&S	EMC32	10.35.10	/	/

ANNEX A: The EUT Appearance

The EUT Appearance are submitted separately.

ANNEX B: Test Setup Photos

The Test Setup Photos are submitted separately.

***** END OF REPORT *****