

「LU20」DRONE

Your personal photographer...

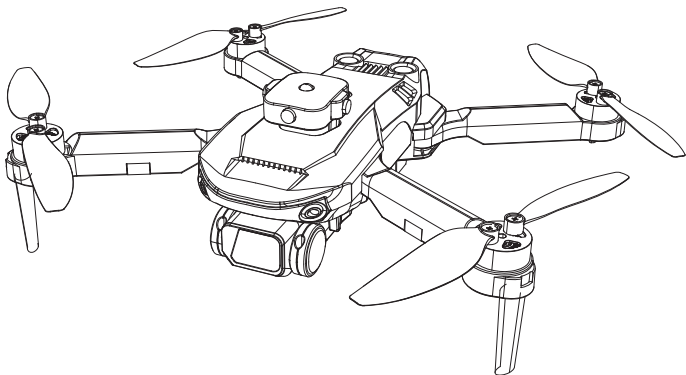

MANUAL

Please keep the manual
for routine maintenance!

Safety instructions

1. please keep the parts of drone out of the reach of children.
2. this drone is very powerful. When using it for the first time, you should push the left control lever slowly to prevent the drone from rising too fast and causing unnecessary collisions and injuries.
3. when a flight is ended, please turn off the power switch of remote control first and turn off the power switch of the drone then.
4. do not place the drone battery in high temperature condition or near flammable or explosive materials.
5. please keep the drone at a distance of 4.5 meters from humans and animals to ensure safety and prevent injury.
6. this drone is suitable for people aged 14 and over, and it should be within the sight of the operator's (coach) to ensure safe flight.
7. do not charge the battery of remote control if the battery is a non-rechargeable battery. The drone must be used with the original batteries.
8. if the drone will not be used for a long time, please take the batteries out of the remote control unit.
9. do not cause a short circuit during the charging.
10. if you do not use the drone for more than 10 days, please discharge the battery of drone to 40-50%(light for a certain time). In this way, the life of battery will be extended greatly.
11. please keep a safe distance from the rotating propeller to prevent injury.
12. all operators should abide by the electromagnetic environment regulations of China on the aeronautical radio (station), which remote control radios are prohibited from being used within 5000 meters of the airport pavement, they are also required to comply with the certificate and broadcasting regulations made by the relevant regulatory authorities, including flight time and area.
13. please assemble the drone under the supervision of an adult.
14. operators are responsible for their safe flight and safe distance. Do not hover and fly over the crowd (more than 12 people).

CATALOG

Know your drone -----	2
Drone	
Drone Description -----	3
Installing the Propellers -----	3
Battery Charging Steps -----	4
Installing Remote control battery-----	4
Remote Control	
Functions Instructions -----	5
Remote control batteries installation	
Preparing Inspection -----	5
Flight environment requirements-----	5
First Using	
2.4G frequency alignment -----	6
One-button take-off and one-button landing -----	6
Advanced Flight Function	
Speed Gear adjustment -----	7
Headless mode -----	7
Camera adjustment -----	7
Rolling -----	7
Photo/Video -----	7
Obstacle Avoidance -----	7
Basic Operation -----	8

Know your drone

Adopt 2.4Ghz Frequency,multi-perso operate at the same time, do not interfere with each other.through remote control to operated the drone,or WIFI connect drone and mobile phone, APP mode control drone,more playing funtions.

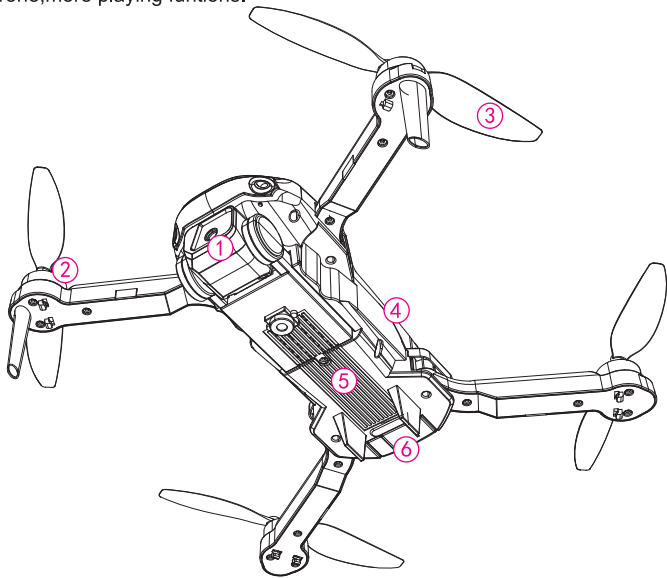

① Camera

② Mortor

③ Propeller blades

④ fuselage top cover

⑤ fuselage down cover

⑥ battery

Drone

Description of drone

The aircraft has good controllability and stability, and with the functions of real-time image transmission, information return, mobile phone control, photography and video, gesture recognition, trajectory flight, one-key return and headless mode, etc. Also it is low power alarm tips.

Installing the Propellers

The Drone comes with replaceable propellers if the originals are broken or badly damaged.

(1) When installing for the first time, please carefully distinguish the propellers type.

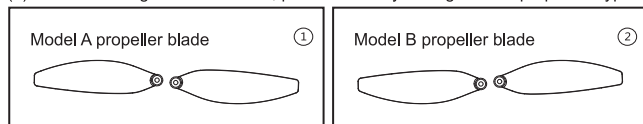

(2) Referring to Figure 3, insert the groove of propeller opener into the bottom of propeller which needs to be replaced. And press the handle of the opener to take down the propeller.

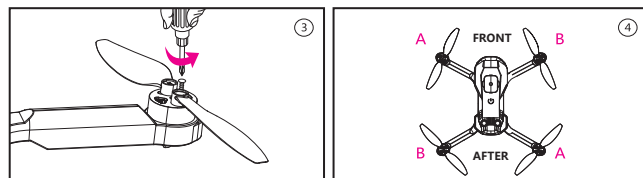

(3) Referring to Figure 4, distinguish between type A and type B propellers, and press the propeller vertically to install them on the motor shaft. The mark can be found on the rotor. It is extremely important to use the correct propeller (A or B) for replacement. Using the incorrect propeller will make the drone out of to control.

Battery Charging Steps

The battery is 3.7V lithium battery, pls using factory-configured USB cable to charge.

⚠ First using drone to fly, please fully charge the battery.

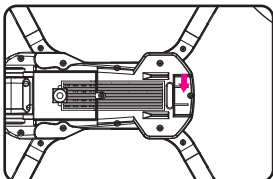

A. Rotate outward, unlock the module battery

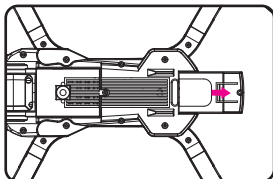

B. Upward, Remove the battery

Charge way

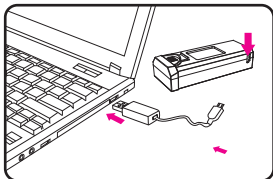

1. USB connect computer charge way

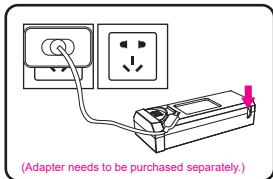

(Adapter needs to be purchased separately.)

2. Connect socket charge way

Charging red light, full of lights off, charging time is about 100 minutes

Remote control batteries installation

Open and remove the battery cover, according to the correct polarity putting into the three AA batteries, battery installation direction as shown in the picture, close the cover and screw it.

(AA * 3PCS Remote control battery needs to be purchased separately.)

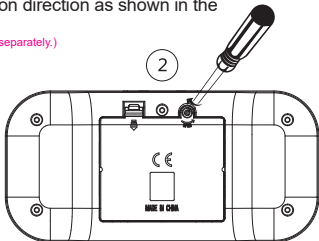
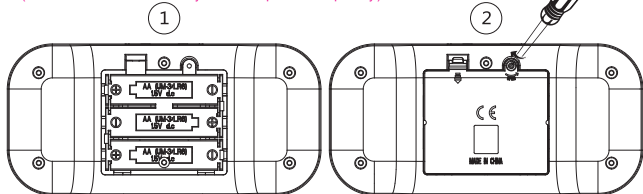

Remote control

Functions Instructions

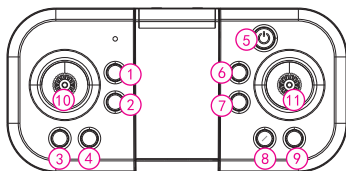

- | | |
|--------------------------------------|------------------------------------|
| ① One key rolling | ⑦ Lens downward fine-tuning |
| ② Headless mode | ⑧ Photo/ Video |
| ③ One key take-off / One key landing | ⑨ Obstacle Avoidance |
| ④ Speed | ⑩ Up & down/ Turn left & right |
| ⑤ Power switch | ⑪ Forward & backward/ Left & right |
| ⑥ Lens upward fine-tuning | |

Preparing for flight

Preparing Inspection

Please inspect the following items before flying

- (1) Whether the drone and remote control are both with fully battery power
- (2) Whether the propellers are installed correctly and without any damage
- (3) Whether the propellers can ran normally when the produce is started
- (4) Check whether the gyroscope ommpleted successfully.
- (5) Whether successful connect smart phone and have transmission image
- (6) Whether environment suitable for flying

Notes:Please check drone'arms are fully open.

Flight environment requirements



Indoor flying : please choose the open spaces that no obstacles, people and pets



Outdoor flying : Please choose sunny, windless or breezyweather.



Keep the aircraft within your sight when flying, away from obstacles, high-voltage lines, trees, etc.



Do not fly when there is strong wind, heavy rain etc weather.

First Using

1. calibration

Turn on the power switch and place the aircraft on the flat ground with the indicator flashes. And then turn on the power switch of the remote control, and the aircraft will automatically matching the frequency. After, pulling out the two rockers to correct the gyroscope with a sound of Di, and the aircraft indicator light is on for a long time, which means that the frequency matching is completed, and the aircraft can be taken off.

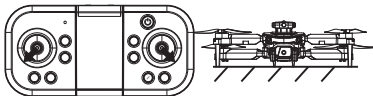

Note that the gyroscope needs to be calibrated every time the flight is restarted, and the aircraft needs to be placed horizontally on the ground.

2. One-button take-off and one-button landing

It is suggested that the height of this product is determined by barometer. Due to the influence of various environmental temperatures and other different factors, it is normal for the aircraft to change evenly at the beginning of flight or at low voltage.

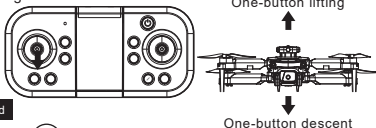

It must be operated after 2.4 G alignment is completed

Advanced Flight Function

Speed adjustment

Press the speed switch button on the remote control to switch the flight speed of the aircraft. When switching to the medium speed gear, the remote control deliver two sounds of Di. When switching to the high gear, the remote control will deliver three sounds of Di. Each time the remote control and the aircraft are turned off and restarted, the aircraft gear will automatically return to the low gear.

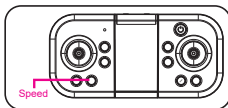

Headless mode

Press headless mode button, start Headless mode, press again exit this mode.

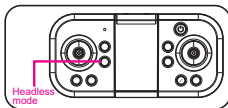

Camera adjustment

The drone camera up or down adjustment.

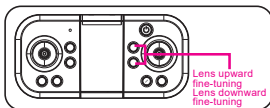

Rolling

Press the rolling button and then push the direction control lever to roll the aircraft in different directions.

Warning: rolling function consumes a lot of power and should be reduced. More important, the novice suggests using it in an open space. (When the battery is fully charged, the rolling time is about 10 minutes. And the function is temporarily suspended during the remaining battery time, while the other functions are normally.)

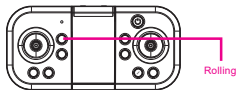

Photo/Video

After turn on the aircraft, press the Photo/Video button to take photos and record video.

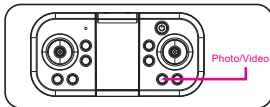





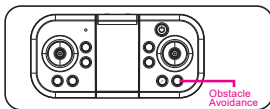

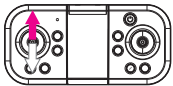

Obstacle Avoidance

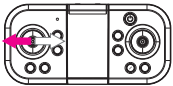
After turning on the aircraft, press the obstacle avoidance mode button. At this time, if the steering rod is turned in any direction, the obstacle avoidance head of the aircraft will automatically sense whether there is an obstacle in that direction. If there is, the aircraft will not be able to fly in that direction.

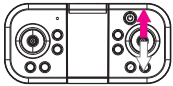

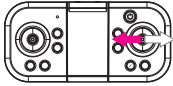
Basic operation

REMOTE CONTROL	DRONE	FLOW
	<p>Fly upward</p>  <p>Fly downward</p> 	<p>Push left control lever forward, the drone ascends vertically. Pull left control lever rearward, the drone descends vertically.</p>
	<p>Spin clockwise</p>  <p>Spin anticlockwise</p> 	<p>Push left control lever rightward, the drone spins clockwise. Push left control lever leftward, the drone spins anticlockwise.</p>
	<p>Pitch forward</p>  <p>Pitch backward</p> 	<p>Push right control lever forward, the drone pitches forward. Pull right control lever rearward, the drone pitches backward.</p>
	<p>Roll leftward</p>  <p>Roll rightward</p> 	<p>Push right control lever rightward, the drone rolls rightward. Push right control lever leftward, the drone rolls leftward.</p>

FCC Statement

This device complies with part 15 of the FCC rules. Operation is subject to the following two conditions: (1) this device may not cause harmful interference, and (2) this device must accept any interference received, including interference that may cause undesired operation.

Caution: Changes or modifications not expressly approved by the party responsible for compliance could void the user's authority to operate the equipment.

NOTE: This equipment has been tested and found to comply with the limits for a Class B digital device, pursuant to part 15 of the FCC Rules. These limits are designed to provide reasonable protection against harmful interference in a residential installation. This equipment generates uses and can radiate radio frequency energy and, if not installed and used in accordance with the instructions, may cause harmful interference to radio communications. However, there is no guarantee that interference will not occur in a particular installation. If this equipment does cause harmful interference to radio or television reception, which can be determined by turning the equipment off and on, the user is encouraged to try to correct the interference by one or more of the following measures:

- Reorient or relocate the receiving antenna.
- Increase the separation between the equipment and receiver.
- Connect the equipment into an outlet on a circuit different from that to which the receiver is connected.

-

Consult the dealer or an experienced radio/TV technician for help important announcement

Radiation Exposure Statement

The device has been evaluated to meet general RF exposure requirement. The device can be used in portable exposure condition without restriction.