

# Electric Vehicle AC Charger Installation Manual

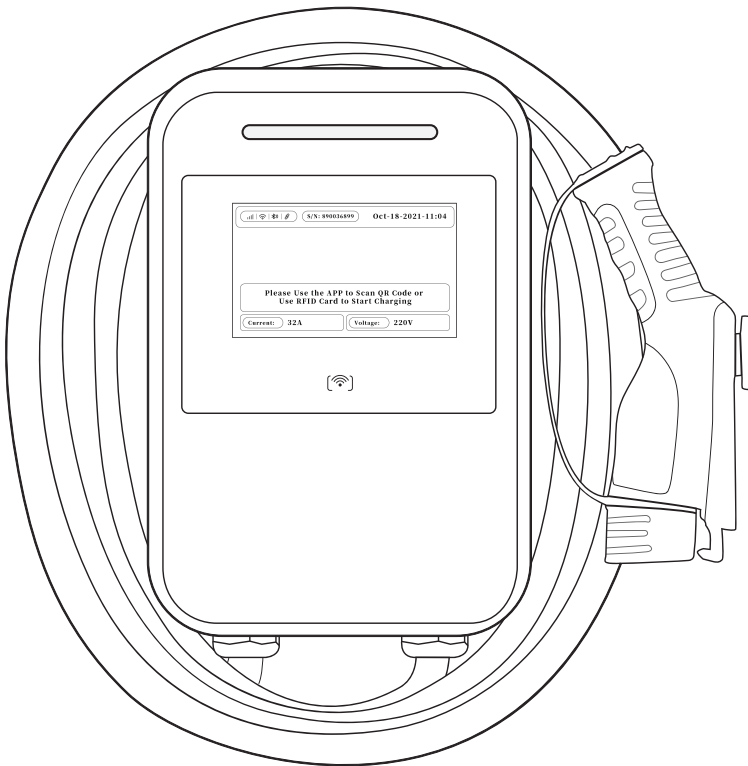

**For model: CS300**



# CONTENTS

<b>1. Safety Instructions</b> .....	<b>1</b>
1.1. Warnings & Cautions.....	1
1.2. Installation Requirements.....	2
1.3. Daily Maintenance .....	2
<b>1. Consignes De Sécurité Importantes</b> .....	<b>4</b>
1.1. Avertissement & Mise En Garde Généraux .....	4
1.2. Exigence Avant L'installation .....	5
1.3. Daily Maintenance .....	5
<b>2. Product Introduction</b> .....	<b>7</b>
2.1. Basic Interface .....	7
2.2. Basic Dimension .....	8
2.3. Specifications .....	9
2.4. Design Standards.....	10
<b>3. Accessories</b> .....	<b>11</b>
<b>4. Tools for Mounting</b> .....	<b>12</b>
<b>5. Plan for Mounting</b> .....	<b>13</b>
<b>6. Operate Your Device</b> .....	<b>17</b>
6.1. Operating Steps with Plug and Charge .....	17
6.2. Operating Steps with RFID Card .....	19
<b>7. Light Codes</b> .....	<b>21</b>
7.1. After Start UP .....	21
7.2. Error and Warning Messages .....	21
<b>8. FCC STATEMENT</b> .....	<b>22</b>
<b>9. Warranty and Maintenance</b> .....	<b>23</b>



# 1. Safety Instructions

## 1.1. Warnings & Cautions

### WARNING

 To avoid fire, injury or death, read and follow the instructions carefully during installation, operation and maintenance.

**DO NOT** put fingers into the electric vehicle connector.

**DO NOT** use this product if the power cord or EV cable is frayed, insulation-broken, or any other signs of damage.

**DO NOT** use this product if the enclosure or the EV connector is broken, cracked, open, or shows any other indication of damage.

**DO NOT** remove cover or attempt to open the enclosure because of risk of electric shock.

 This device should be supervised when used around children.

 This device must be grounded.

 To avoid the risk of fire or electric shock, do not use this device with an extension cord.



 The suitability of the use of flexible cord in accordance with CE code, part I, rule 4-012, is to be determined by the local inspection authority.

 To reduce the risk of fire, connect only to a circuit provided branch circuit over-current protection in accordance with the CSA C22. 1 – 15 Canadian Electrical Code, Part 1 (Canada) or NOM-001-SEDE Electrical installations (utility) (Mexico) or ANSI / NFPA 70 National Electrical Code (USA).





Circuit Breaker Options					
<b>Output Amperage (A)</b>	16A	32A	40A	48A	80A
<b>Circuit Breaker Options (A)</b>	20A	40A	50A	60A	100A

## 1.2. Installation Requirements

### WARNING



-  Disconnect electrical power prior to installing the charging station.
-  Be sure to preview the user manual and ensure local building and electrical codes are reviewed before installing the AC charger.
-  The AC charger should be installed by a qualified technician according to the user manual and local safety regulations.

### CAUTION

-  Use appropriate protection when connecting to the main power distribution cable.
-  Type B, C or D breaker with the rating current for table should be installed in the upstream AC distribution box.
-  Disconnect switch for each ungrounded conductor of AC input shall be provided by others in accordance with the National Electric Code, ANSI/NFPA70.
-  The device shall be mounted at the height between 600 mm and 1200 mm from ground.
-  Please keep the charger in a clean area with low humidity. Not recommended to be installed in coastal environments with high humidity or thick dust.

## 1.3. Daily Maintenance

### CAUTION

-  Avoid moisture or water in the charger. If there is water or moisture ingress in the charger, it is necessary to immediately power off to avoid immediate danger and notify the professionals to carry out maintenance before next use.
-  Please use the charger properly. Do not hit or press hard on the enclosure. If it

is damaged, please contact a professional technician.

- ❗ Avoid placing the charger near hot objects and at high temperature locations and away from dangerous substances such as flammable gases and corrosive materials.
- ❗ To avoid any danger, please do not put any heavy objects on the charger.

# 1. Consignes De Sécurité Importantes

## 1.1. Avertissement & Mise En Garde Généraux

### AVERTISSEMENT

 Pour éviter les risques d'incendie, de blessure ou de mort, il faut lire et suivre soigneusement les instructions pendant l'installation, l'utilisation et l'entretien.

**Ne mettez pas** les doigts dans le connecteur du véhicule électrique.

**N'utilisez pas** ce produit si le cordon d'alimentation flexible ou le câble EV est effiloché, isolé ou présentant tout autre signe de dommage.

**N'utilisez pas** ce produit si le boîtier ou le connecteur EV est cassé, fissuré, ouvert ou montre toute autre indication de dommage.

**Ne retirez pas** le couvercle et n'essayez pas d'ouvrir le boîtier en raison du risque de choc électrique.

 Cet appareil doit être surveillé lorsqu'il est utilisé à proximité d'enfants.

 Cet appareil doit être mis à la terre.

 Pour éviter tout risque d'incendie ou de choc électrique, n'utilisez pas cet appareil avec une rallonge électrique.

 L'adéquation de l'utilisation du cordon flexible conformément au code ce, partie i, règle 4-012, doit être déterminée par l'autorité d'inspection locale compétente.

 Pour réduire les risques d'incendie, ne connecter qu'à un circuit protection contre les surintensités des circuits de dérivation conformément à la norme canadienne CSA C22. 1-15 Code électrique, partie 1 (Canada) ou NOM-001-SEDE Installations électriques (Mexique) ou ANSI / NFPA 70 National Electrical Code (États-Unis).



**Tableau Des Options Du Disjoncteur**

<b>Courant De Sortie (A)</b>	16A	32A	40A	48A	80A
<b>Options De Disjoncteur (A)</b>	20A	40A	50A	60A	100A







## 1.2. Exigence Avant L'installation

### AVERTISSEMENT

-  Assurez-vous de consulter le manuel d'utilisation et assurez-vous que les codes locaux du bâtiment et de l'électricité sont passés en revue avant d'installer le chargeur.
-  Débranchez l'alimentation électrique avant d'installer la station de charge.
-  Le chargeur CA doit être installé par un technicien qualifié conformément au manuel d'utilisation et aux réglementations de sécurité locales.

### MISE EN GARDE

-  Utilisez une protection appropriée lors de la connexion au câble de distribution d'alimentation principal.
-  Un disjoncteur de B, C ou D avec le courant nominal indiqué dans le tableau doit être installé dans le boîtier de distribution CA en amont.
-  L'interrupteur de déconnexion pour chaque conducteur non mis à la terre de l'entrée CA doit être fourni par des tiers conformément au Code national de l'électricité, ANSI/NFPA70.
-  Cet appareil doit être monté à une hauteur entre 600 mm (2 pieds) et 1200 mm (4 pieds) du sol.
-  Veuillez conserver le chargeur dans un endroit propre et peu humide. Il n'est pas recommandé de l'installer dans des environnements côtiers à forte humidité ou à forte poussière.

## 1.3. Daily Maintenance

### MISE EN GARDE

-  Évitez l'humidité ou l'eau dans le chargeur. En cas d'infiltration d'eau ou d'humidité dans le chargeur, il est nécessaire de l'éteindre immédiatement pour éviter tout

danger immédiat et d'avertir le personnel professionnel d'effectuer l'entretien avant la prochaine utilisation.

- ❗ Veuillez utiliser le chargeur correctement. Ne frappez pas ou n'appuyez pas trop fort sur le boîtier. Si le boîtier est endommagé, veuillez contacter un technicien professionnel.
- ❗ Évitez de placer le chargeur à proximité d'objets chauds et à des endroits à haute température et loin de substances dangereuses telles que des gaz inflammables et des matériaux corrosifs.
- ❗ Pour éviter tout danger, veuillez ne pas mettre d'objets lourds sur le chargeur.

## 2. Product Introduction



**CAUTION:** Avoid placing the charger near hot objects or high temperature locations and away from dangerous substances such as flammable gases and corrosive materials.

### 2.1. Basic Interface

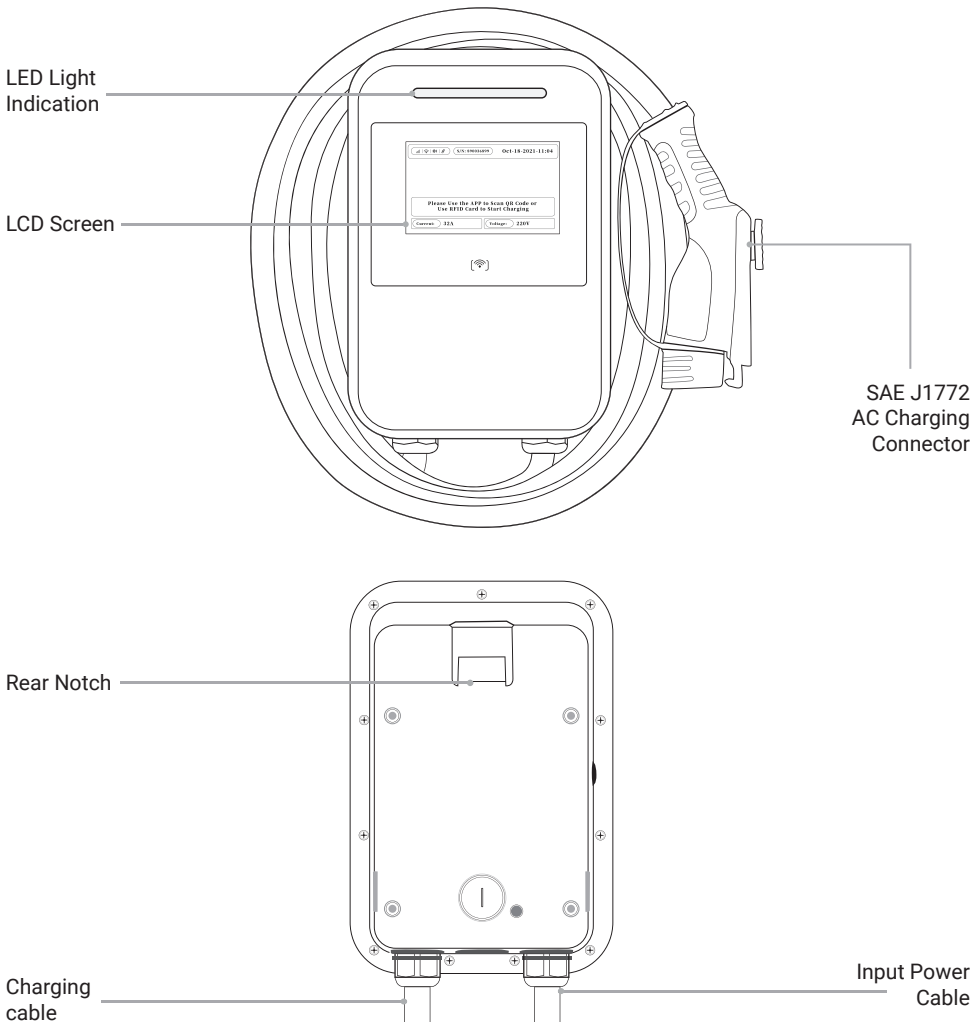

## 2.2. Basic Dimension

### ENCLOSURE

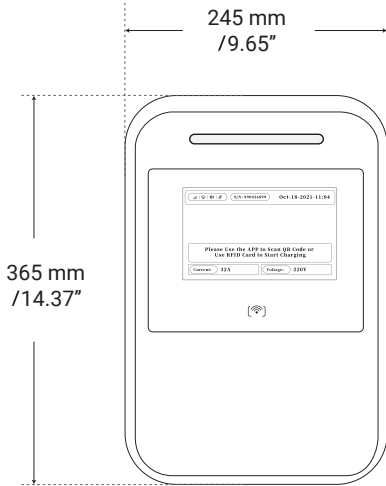

Front View

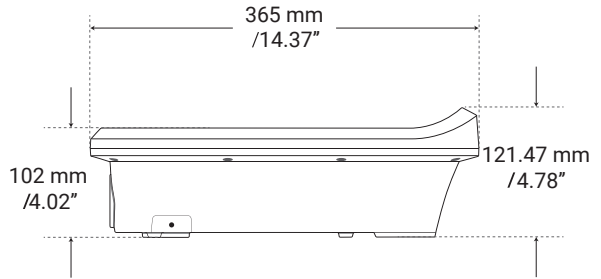

Left View

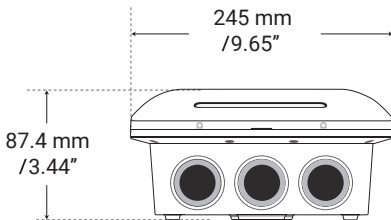

Bottom View

### WALL-MOUNTED HOLES

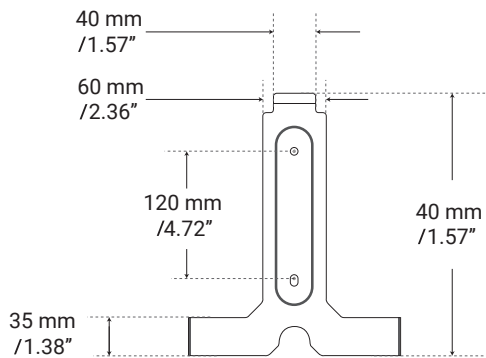

## 2.3. Specifications

Model Name		CS300-32A	CS300-40A	CS300-48A	CS300-80A
Power Specification	Input AC Rating	208-240Vac			
	Max. AC Current	32A	40A	48A	80A
	Frequency	60Hz			
	Max. Output Power	7.6kW	9.6kW	11.5kW	19.2kW
User Interface & Control	Display	5"(7" optional) LCD Screen			
	LED Indicator	Yes			
	Push Buttons	Restart Button			
	User Authentication	RFID(ISO/IEC 14443 A/B), APP			
Communication	Network Interface	LAN(Standard), Wi-Fi/Bluetooth/3G/4G Optional			
	Communication Protocol	OCPP1.6 J/OCPP2.0.1 Upgradeable			
	Communication Function	ISO/IEC 15118 Optional			
Environment	Operating Temperature	-22 °F to 122 °F			
	Humidity	5%~95% RH, Non-condensing			
	Altitude	≤6562ft(2000m), No Derating			
	IP/IK Level	NEMA Type3R(IP65)/IK10			
Mechanical	Cabinet Dimension (W×D×H)	9.65"×14.37"×4.78"(245mm×365mm×121.47mm)			
	Weight	16.98lbs(7.7kgs)			
	Cable Length	18ft(5.5m)(Standard)/25ft(7.5m)(Optional)			
Protection	Multiple Protection	OVP(Over Voltage Protection), OCP(Over Current Protection), OTP(Over Temperature Protection), UVP(Under Voltage Protection), SPD(Surge Protection Detection), Grounding Protection, SCP(Short Circuit Protection), Control Pilot Fault, Relay Welding Detection, CCID Self-test			
Regulation	Safety	UL 2594, UL2231-1/-2			
	Certificate	ETL, FCC			
	Charging Interface	SAE J1772 Type 1			

## 2.4. Design Standards

**UL 2594:** Electric Vehicle Supply Equipment.

**UL 2231-1:** UL Personnel Protection Systems for Electric Vehicle (EV) Supply Circuits: General Requirements.

**UL 2231:** Personnel Protection Systems for Electric Vehicle (EV) Supply Circuits: Particular Requirements for Protection Devices for Use in Charging Systems.

**UL 2251:** Plugs, Receptacles and Couplers for Electric Vehicles.

**UL 62:** Flexible Cords and Cables.

**UL 991:** Tests for Safety-Related Controls Employing Solid-State Devices.

**UL 1998:** Software in Programmable Components.

**NFPA 70 Article 625:** National Electrical Code, Electric Vehicle Charging System UL 840 (Clearance and Creepage).

### 3. Accessories

Check the box to ensure you have this installation guide and these parts:

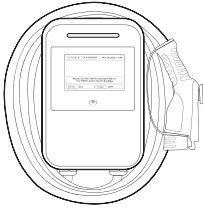

1 AC Charger



2 User Manual

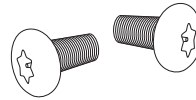

3 M4x8 Screws\*2

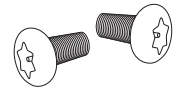

4 M3x8 Screws\*2

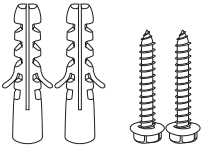

5 M6 Hexagonal Expansion Screws\*2

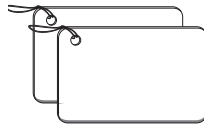

6 Standard RFID Cards\*2

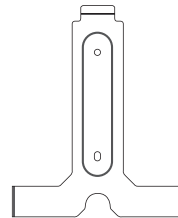

7 Mounting Bracket

No.	Product Name	Quantity	Description
1	AC Charger	1	With attached input power cable and output charging cable.
2	User Manual	1	PDF version available online.
3	M4x8 Screws	2	For installing the AC Charger to the Bracket.
4	M3x8 Screws	2	For fastening front cover on AC Charger
5	M6 Hexagonal Expansion Screws	2	For installing the Mounting Bracket to the wall / structure.
6	Standard RFID Cards	2	To start/stop charger for the unit with RFID reader.
7	Mounting Bracket	1	For easy drilling of 2 screws holes for AC Charger.

## 4. Tools for Mounting

Tools required before installing the Wall-mounted charger, gather the following tools:

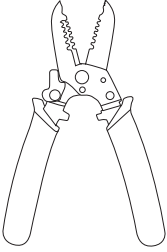

1 Wire stripper

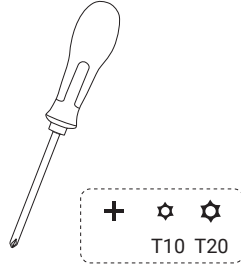

2 Phillips and T10, T20 screwdriver

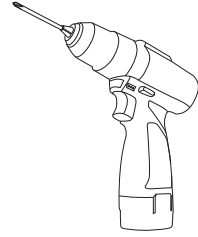

3 Drill

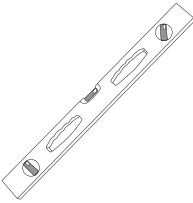

4 Level

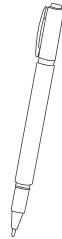

5 Pencil or marker

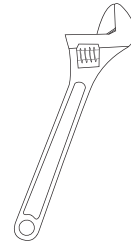

6 Adjustable wrench

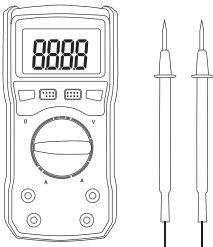

7 Voltmeter or digital multimeter (for measuring AC voltage at the installation site)

**NOTE:** The above tools are very important, get them ready prior to installation.



## 5. Plan for Mounting



**WARNING:** In areas with frequent thunderstorms, add surge protection at the service panel for all circuits. Ensure all power and ground connections, especially those at the breaker and bus bar, are clean and tight.



**CAUTION:** Not recommended to be installed in coastal environments with high humidity or thick dust.

### STEP 1

Select the appropriate mounting location with electrical capacity.

- I. Ensure the owner has chosen a mounting location that allows the charging cable to reach the car's charging port while still providing slack.
- II. The device must be anchored on a solid wall or a stud with the dimensions: 2" x 4".
- III. The device shall be mounted at height between 2 feet (600mm) and 4 feet (1200mm).

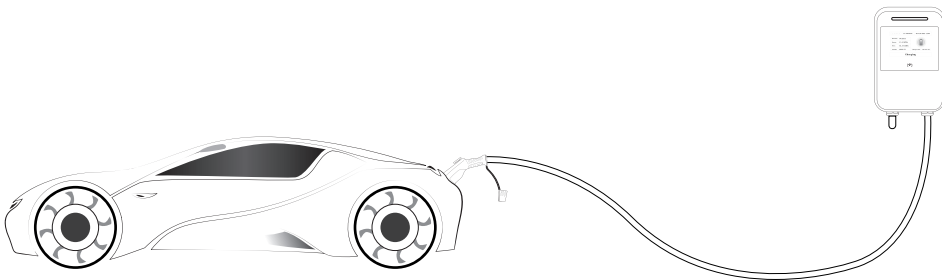

### STEP 2

Use a level to verify if a bracket is horizontally aligned and mark the holes by one pencil.

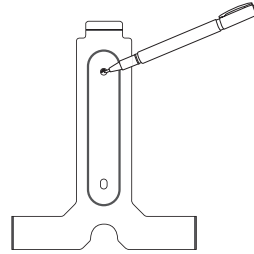
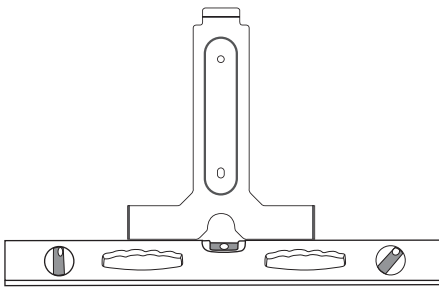

**STEP 3**

Drill 2 Screw Holes with a diameter of 0.33" and a depth of 2.05" by using #7 mounting bracket.

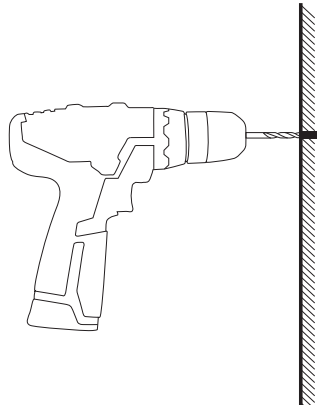

**STEP 4**

Nail #5 two expansion rubber sleeves into the holes and nail #5 two M6 hexagonal expansion screws to secure the wall-mounted bracket on the wall. Then level the brackets.

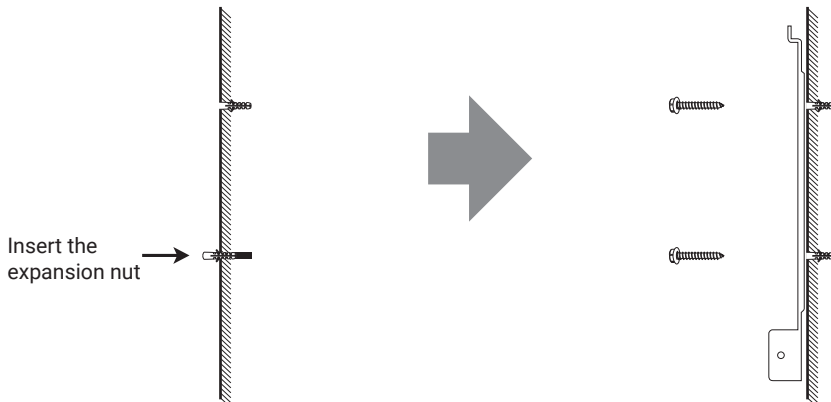

**STEP 5**

Align the rear notch of charger with the wall-mounted bracket and fit the screw holes of the right and left side with #3 M4×8 Screws.

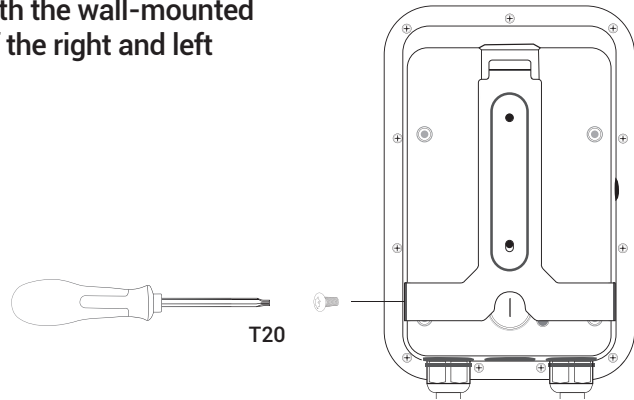

**STEP 6**

**Wire the Circuit**

**WARNING**

- ⚠ This device must be grounded. Disconnect electrical power prior to installing the charging station.
- ⚠ Improper connection of the equipment-grounding conductor would result in a risk of electric shock. Check with a qualified electrician or service man if you are not sure whether the product is properly grounded. Do not modify the plug provided with the product – if it doesn't fit the outlet, have a proper outlet installed by a qualified electrician.

**CAUTION**

- ⚠ Use appropriate protection when connecting to the main power distribution cable.

For the safety purpose, please set circuit breaker protection in the input part of EV Charger. Please follow the instructions below:

Circuit Breaker Options					
<b>Output Amperage (A)</b>	16A	32A	40A	48A	80A
<b>Circuit Breaker Options (A)</b>	20A	40A	50A	60A	100A

**STEP 7**

Please unclick the shelf with slotted screwdriver, connect L1 with grid L1, L2 with grid L2 and lead the PE to the grid PE. Click back the shelf, and fix the front cover back and tighten with #8 M3X8 Screws 2 screws at the bottom.

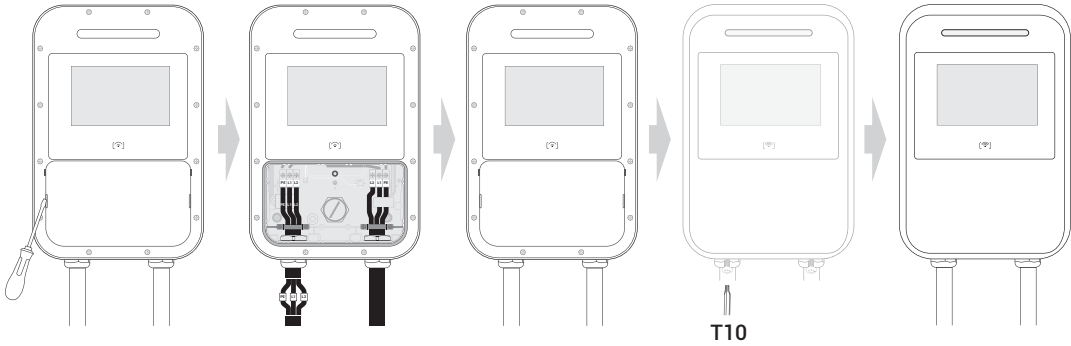
**STEP 8**

Overall outlook after installation

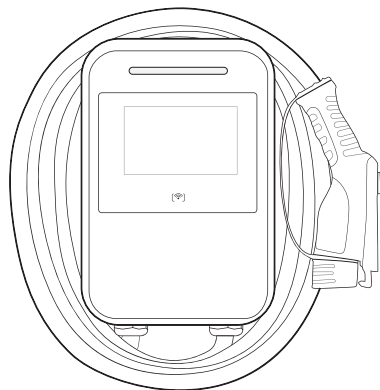



## 6. Operate Your Device

### WARNING

 This device should be supervised when used around children.

### CAUTION

-  Please use the charger properly. Do not hit or press hard on the enclosure. If the case is damaged, please contact a professional technician.
-  To avoid any danger, please do not put any heavy objects on the charger.

### 6.1. Operating Steps with Plug and Charge

#### STEP 1

**Standby Mode:** After being powered on, the lights will be all on, **blue light (STANDBY)**, **green light (CHARGING)** and **red light (FAULT)**. Then **the blue light (STANDBY)** is constantly on in standby mode.

Standby

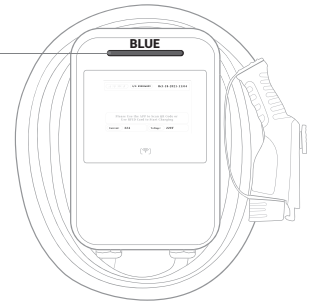

\*Figures are for reference only

#### STEP 2

**Plug the Charging Connector:** Please plug the charging connector into the vehicle charging inlet

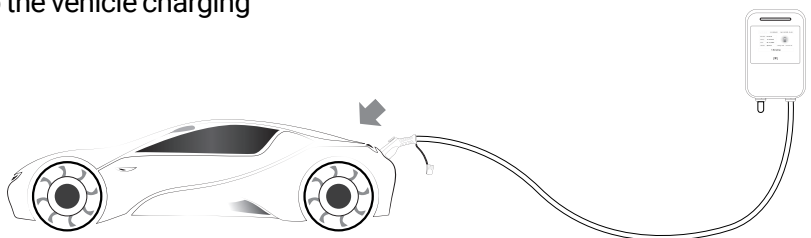

**STEP 3**

**CHARGING:** The green light (**CHARGING**) turns, to flash automatically, charging is in process. You can see "**Duration, Energy, Price, Amount, SN**" in the LCD Screen.

Charging  **GREEN**

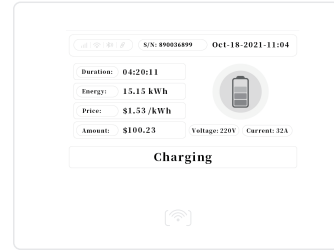

\*Figures are for reference only

**STEP 4**

The green light (**CHARGE**) turns to flash automatically, charging is in process.

If the red light (**FAULT**) is on, plug the vehicle connector again.

If red light is still on, please refer to "**7.2. Error and Warning Messages**".



**Charging**

**Fault**

\*Figures are for reference only

**STEP 5**

**Charging finished:** The charging process will be stopped once swipe RFID, the number of total kWh will be shown, this indicates the total kWh your car has received. Then please pull out the charging connector to stop the charging process.



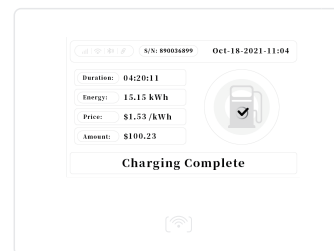

\*Figures are for reference only

## 6.2. Operating Steps with RFID Card

### STEP 1

**Standby Mode:** After being powered on, the lights will be all on, **blue light (STANDBY)**, **green light (CHARGING)** and **red light (FAULT)**. Then **the blue light (STANDBY)** is constantly on in standby mode.

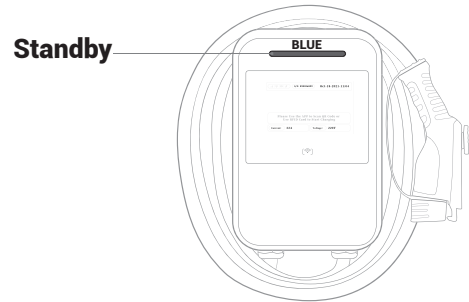

\*Figures are for reference only

### STEP 2

**Plug the Charging Connector:** Please plug the charging connector into the vehicle charging inlet.

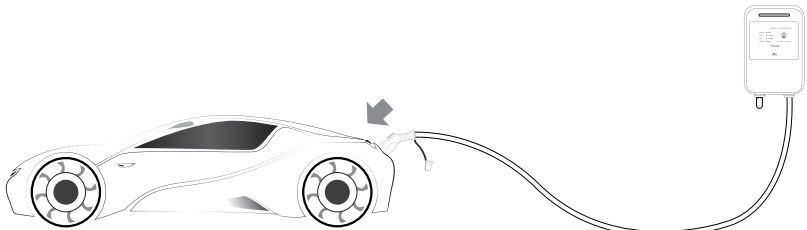

\*Figures are for reference only

### STEP 3

Tap the standard RFID to start/stop charging.



\*Figures are for reference only

**STEP 4**

**Charging:** When the charging is going on, you will see the following information on the LCD screen "*Duration, Energy, Price, Amount, SN*".

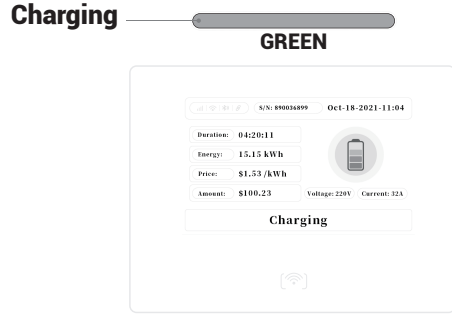

\*Figures are for reference only

**STEP 5**

**The green light (CHARGE)** turns to flash automatically, charging is in process.

If **the red light (FAULT)** is on, plug the vehicle connector again.

If red light is still on, please refer to "**7.2. Error and Warning Messages**".

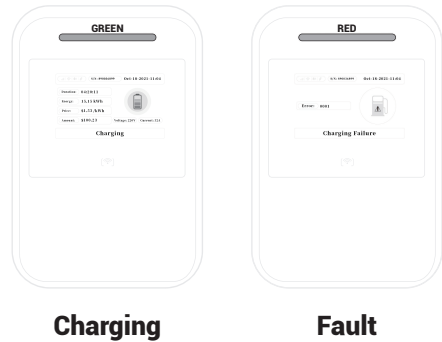

\*Figures are for reference only

**STEP 6**

**Charging finished:** The charging process will be stopped once swipe RFID, the number of total kWh will be shown, this indicates the total kWh your car has received. Then please pull out the charging connector to stop the charging process.

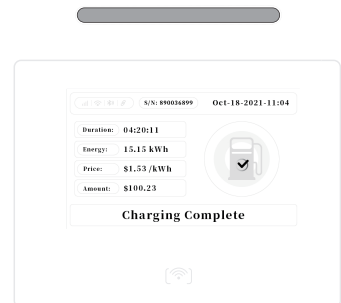

\*Figures are for reference only



## 7. Light Codes

### 7.1. After Start UP

<b>Standby Waiting to plug in</b>	<b>Waiting to Charge, Communicating with Vehicle</b>	<b>Charging in Progress</b>	<b>Finished Charging</b>	<b>Fault</b>
Solid Blue	Solid Green	Green Blinking	Solid Green	Solid Red

### 7.2. Error and Warning Message

<b>Status</b>	<b>Screen Display</b>	<b>Remark</b>
Off Ground	0001	Auto Recover
RCD Abnormal	0002	Auto Recover
Over Current Protection	0004	Auto Recover
Over Voltage Protection	0008	Auto Recover
Under Voltage Protection	0016	Auto Recover
Energy Meter Fault	0032	Contact Customer Service
Control Pilot Fault	0128	Auto Recover
Over Temperature Protection	0256	Auto Recover
Ground Fault	0512	Auto Recover
Ground Self-Test	1024	Auto Recover

## 8. FCC STATEMENT

This device complies with part 15 of the FCC Rules.

**Operation is subject to the following two conditions:** This device may not cause harmful interference, and this device must accept any interference received, including interference that may cause undesired operation.

**Caution:** Changes or modifications to this unit not expressly approved by the party responsible for compliance could void the user's authority to operate the equipment.

**Note:** This equipment has been tested and found to comply with the limits for a Class A digital device, pursuant to part 15 of the FCC Rules. These limits are designed to provide reasonable protection against harmful interference when the equipment is operated in a commercial environment. This equipment generates, uses, and can radiate radio frequency energy and, if not installed and used in accordance with the instruction manual, may cause harmful interference to radio communications. Operation of this equipment in a residential area is likely to cause harmful interference in which case the user will be required to correct the interference at his own expense.

**WIFI module :** Contains FCC ID:2AC7Z-ESP32WROOM32U

**LTE module :** Contains FCC ID:XMR201909EC25AFX

To satisfy FCC RF exposure requirements, a separation distance of 20cm or more should be maintained between the antenna of this device and persons during device operation. To ensure compliance, operations at closer than this distance is not recommended.

## 9. Warranty and Maintenance

The warranty period for this charger is three years.

During the warranty period for any malfunction under normal use according to the User Manual and Service Instructions (to be determined by certified maintenance technicians of sellers), the product shall be repaired free of charge. Except for the following situations, the charger shall be subject to the above warranty terms:

1. The warranty certificate cannot be provided or the contents of the warranty certificate are modified or inconsistent with the label indication of the repaired product.
2. Those who are unable to provide valid proof of purchase.
3. Those who exceed the manufacturer's specified warranty period.
4. Those who damage the product due to not following the product service instruction for use, maintenance and storage.
5. Damage or malfunction caused by external object entering.
6. Unauthorized repair, disassembly or modification.
7. Damage caused by force majeure (such as lightning, excessive voltage, earthquake, fire, flood, etc.).
8. Malfunction and damage caused by other unavoidable external factors. Malfunction and damage caused by improper use of equipment, such as water or other solutions entering into the equipment.
9. Malfunction and damage caused by the grid power supply and voltage which is not specified for use with the charger equipment.

The above guarantees shall be made solely, and no other express or implied warranties shall be made (including the implied warranties of merchant ability, particular and applicable reason-ableness and adaptability, etc.) whether in the contract, civil negligence, or other aspects, the Company shall not be responsible for any special, incidental or consequential damages.

