

Quick User Guide

WiFi Camera



Available on the **App Store** and **Google Play**

Download CAM720 APP from APP store or Google play, or by Scanning the QR code above.

Sign up an account by email and login, please read the instructions carefully before use.

Camera introduction

Note: The reset button position will be different for different models, and the picture is for reference only

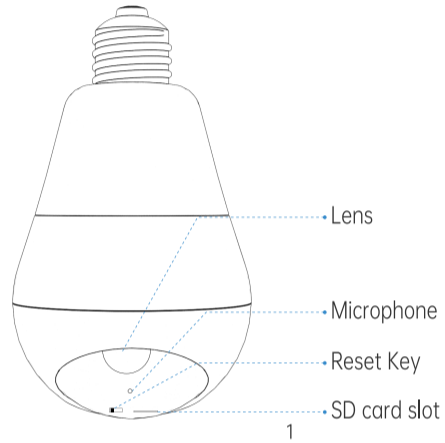

- 1

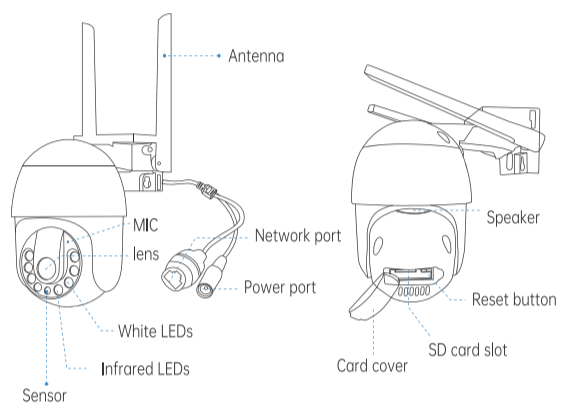

- 2

Q1:What should I pay attention to before WiFi connection?

A1:APP permission: PLS turn on GPS and all permission select "allow", IOS phone:pls enable location action by setting-privacy/location ser vice-cam720 APP-enable location select "always"

WiFi requirement: PLS ensure the Name and password of the router are not more than 16 characters

Note: pls take the camera near the router for first connection, cellphone connected the same wifi.

Q2:What should I pay attention to before Wired connection?

A2:Ethernet cable:pls check the cable is working and check the indicator of the network port is always on

NOTE: pls confirm the cellphone connected the same wifi of the router that camera connected.

Q3:How to do if the camera is often offline?

A3:Adapter: pls check the adapter and outlet for the camera, or check the camera's record, if there are some broken records, the problem is in power, camera can record without wifi

Network: pls check the network, is it normal

APP permission: pls check mobile network permission on the APP is enable, otherwise, the APP can't work under mobile network.

Reconfigure the camera: delete the camera from the APP> add the camera after reset the camera as the first connection

- 3

Sign up & Login

Register an account: Click "Register" > enter your email address, set your APP password, check the verification code, and wait for the verification to be completed and then jump directly to the APP list.

Note: if you don't want register an account, it can't remote, but you can use stand alone mode to view the camera. This mode only support Local view.

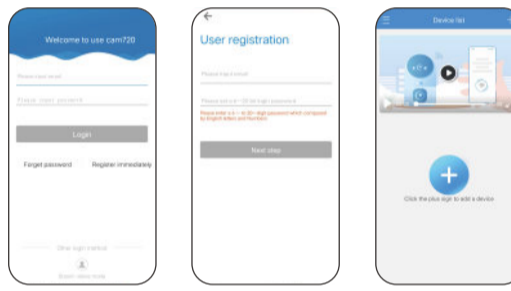

- 4

WiFi connection

Power and Reset the camera: PLS plug the adapter for the camera, Reset the camera by long press the reset button for 5 seconds until you hearing "DI", camera will do self-inspection after "DI" 2 times

Requirement Before WiFi connection: pls read Q1 above: Don't ban permissions of the APP

NOTE: some models only support 2.4GHz WiFi, cellphone connected 2.4G WiFi for first connection, if camera support 2.4G/5G dual-band WiFi, pls choose the right WiFi according to the place you want to install (2.4GHz signal transfer distance is longer, 5GHz is shorter but faster in speed).

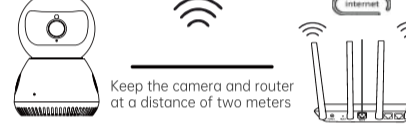

The device connects to the router via WiFi

- 5

- 6

1.In the APP: click "+"> select "WiFi connection"

2.Check "configure the network when you hear the device tone" > Tap "next step"



- 7

3.Follow the Tips Shown in the APP(pls connect WiFi to JAA-*** or JAA-***, and then back to Cam720 APP) to find the Camera's WiFi(named JAA-** / JAA-***), after connected it pls back to cam720 APP

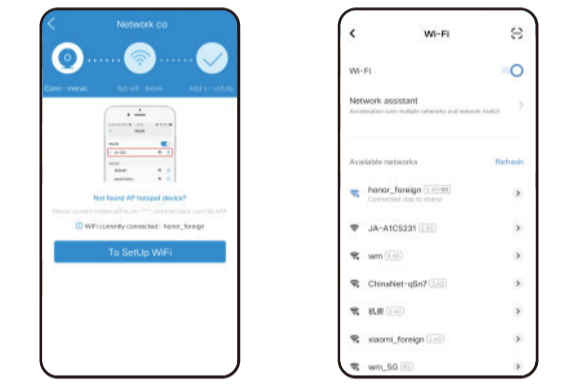

- 8

4. Enter the right password of the WiFi that your phone connected to, Tap "Next Step"

5. When the device is connected, pls wait patiently until camera is online", then click the video to view

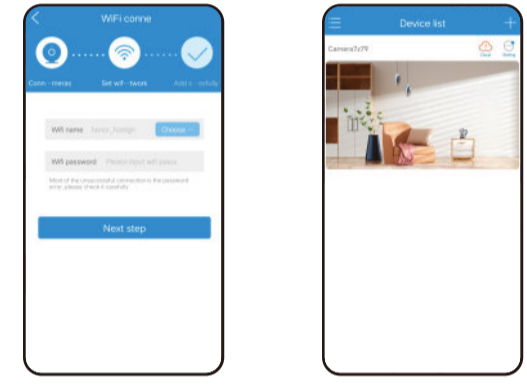

Wired Connection

Plug the power supply and Ethernet cable to the router: PLS plug the adapter for the camera, and connect the camera with the Ethernet cable to the router

Reset the camera: Long press the reset button about 5-8s until you hearing Prompted, select wired connection to connect it.

NOTE: pls read Q2 above if there is a problem in wired connection if the camera has a Network port, it supports wired/WiFi connection, otherwise, pls select wifi connection to connect.

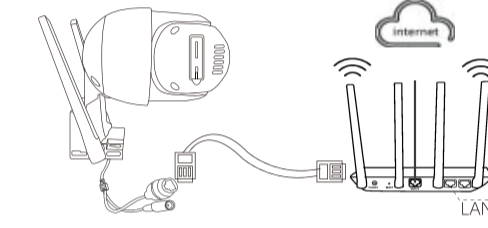

Connect to the router LAN port through a network cable

- 9

- 10

1. In the APP, click "+"> select "network cable connection"

2. Search and select the IP of the camera, click to add

3. Click the video to view until hearing "camera is online"

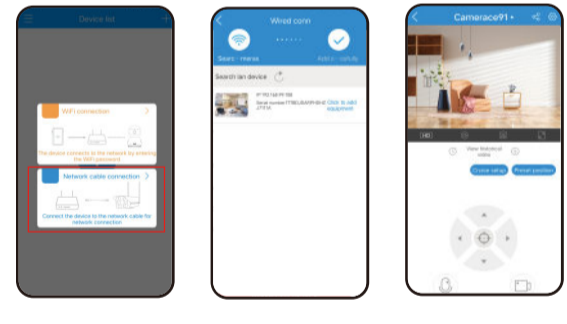

- 11

1. Return to the device list

2. Share the device

3. More function settings

4. Switch image effects

5. Turn on the microphone

6. Screenshot to save the image

7. Switch into Full-screen image

8.Playback (SD card Playback / Cloud Playback)

9. Setting of cruise

10. Preset point settings

11. T2P rotation control

12. Turn on voice intercom

13. Turn on screen record function

1. Start Live video

2. Subscribe Cloud storage

3. More functions setup

4. User information

5. Modify the device name

6. Add more cameras

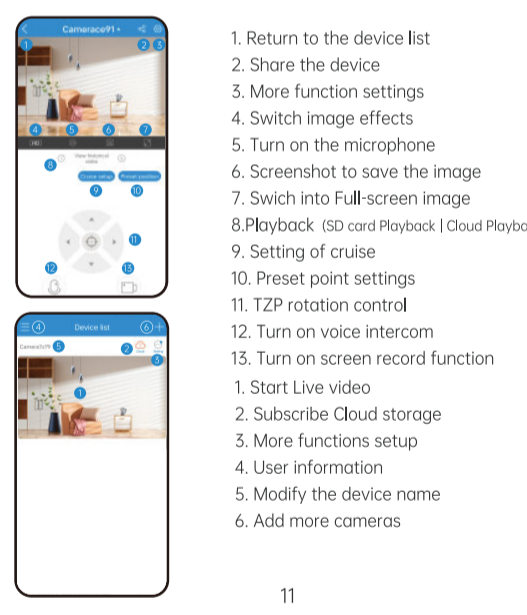

- 12

1. Back to the device list

2. Modify the device name

3. Share equipment

4. SD card setup

5. Detection alarm settings

6. Buy cloud storage

7. Image Flip: upside-down

8. Choose a call mode

9. Enable/Disable Auto tracking

10.Indicator light switch

11. Choose night vision mode

12. Set the time zone

13. Switch WiFi network

14. Camera information

15. Delete the camera

17.Transfer the camera to another account

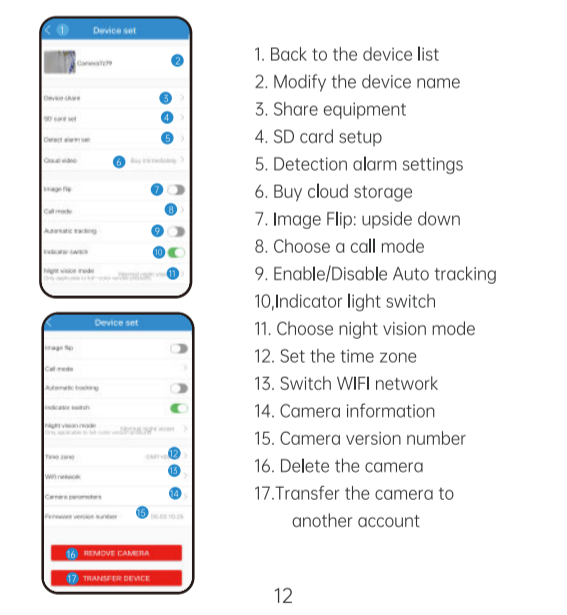

Share

Share your camera with your friends and families

1>Your friend should have an account of cam720 APP.

2.In main account, enter the Email of the friend APP account or scan the QR code of the account to share it.

3.Freely set the permission on this shared account.

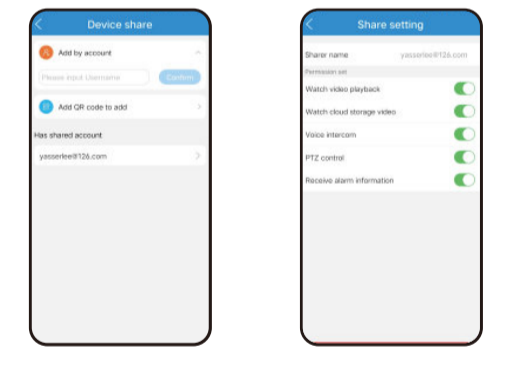

- 13

Playback

1.Turn on the playback function and two Record method available: SDcard record(8-128G) and Cloud Record.

2.New users can get a trial cloud storage for free, pls don't miss it.

3.SD card record supports 3 record modes: 24/7 continuous, motion-triggered, scheduled record.

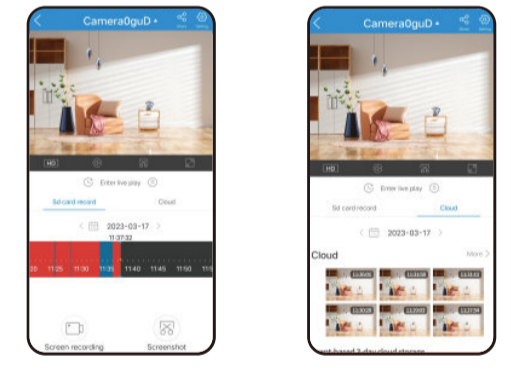

- 14

Installation

Indoor Camera-stent assembly

1.This camera can be placed on the desktop, or do cell or Wall mounted.

2.Attach the bracket to the wall and make a mark on the hole to punch holes, and use a 6mm drill bit to get the holes, then Stuff the rubber stopper into the hole.

3.Align the bracket with the hole position and tighten the screws. Fix the body, hold the body and turn it tightly.

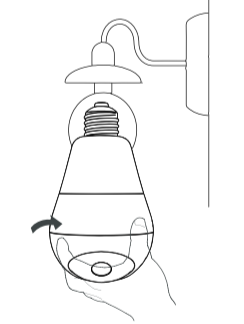

- 15

Outdoor camera

1.Attach the bracket to the wall and make a mark on the hole to punch holes, and use a 6mm drill bit to get the holes, then Stuff the rubber stopper into the hole.

2.Select a suitable location and install expansion screws on the wall for example, if it's a wooden wall expansion screws are not requirement.

3.Align the bracket with the hole position and tighten the screws.

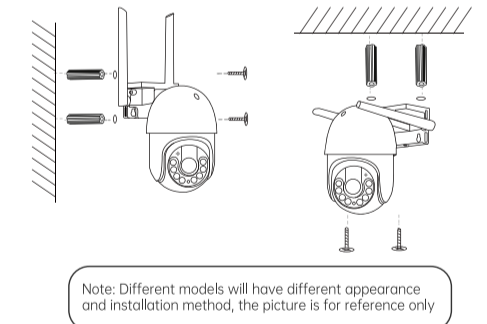

Note: Different models will have different appearance and installation method, the picture is for reference only

- 16

Important Use Notice

1. The use of unapproved or incompatible power adapters may cause fire, explosion or other dangers.
- This product and accessories contain some small parts to avoid children contact and cause swallowing small parts, causing suffocation or other hazards, in addition, this product is not a toy, children should be used under adult supervision.
- Please use this product within the appropriate temperature range. When the ambient temperature is too high or too low, it may cause errors, avoid rain or moisture on the product and its accessories, so as not to affect the use of the product.
- Suitable for equipment, suitable for areas with an altitude of 2000 meters and below.
- WiFi device should be under a good wifi signal area, pls avoid choosing a closed environment installation which may cause bad signal.

- 17

Important Use Notice

1. Failed in connection at first connection? PLS view the operation video at last page (Scan the QR code to view), and pls view wifi connection steps from Page5, if still failed, pls message seller to get support, we also offer online support if you need.
- Change a router, camera is offline? pls delete the camera from the APP, and take the camera to near the new router/power and reset it, search and add it.
- Stop record? 1.Check the status of the SD card in the APP 2.Check the record setup 3.Format SD card 4.change a SD card to test 5.message Seller to get support.
- Camera is offline? Read the Q5 at page5 and follow it to check, if there is further question, pls message seller to get support
- The instructions are not detailed enough? It's general quick user guide, so less many details, pls contact seller to get the E-user manual and operation video according to your order.

- 18

After-sale Service & Tech Support

We offer a one-year warranty and lifetime technical support! As long as there is any problem, please feel free to contact the purchase store, we will quickly provide an effective solution.

By scanning the QR code below to access Youtube, Select the right operation video for your camera according to APP and Model of the camera or message seller to get the operation video directly.



Operation videos (Scan the QR code to view)

- 19

FCC Warning

This device complies with part 15 of the FCC rules. Operation is subject to the following two conditions: (1) this device may not cause harmful interference, and (2) this device must accept any interference received, including interference that may cause undesired operation.

Changes or modifications not expressly approved by the party responsible for compliance could void the user's authority to operate the equipment.

NOTE: This equipment has been tested and found to comply with the limits for a Class B digital device, pursuant to part 15 of the FCC Rules. These limits are designed to provide reasonable protection against harmful interference in a residential installation. This equipment generates uses and can radiate radio frequency energy and, if not installed and used in accordance with the instructions, may cause harmful interference to radio communications. However, there is no guarantee that interference will not occur in a particular installation. If this equipment does cause harmful interference to radio or television reception, which can be determined by turning the equipment off and on, the user is encouraged to try to correct the interference by one or more of the following measures:

- Reorient or relocate the receiving antenna.
- Increase the separation between the equipment and receiver.
- Connect the equipment into an outlet on a circuit different from that to which the receiver is connected.
- Consult the dealer or an experienced radio/TV technician for help.

Radiation Exposure Statement

This equipment complies with FCC radiation exposure limits set forth for an uncontrolled environment. This equipment should be installed and operated with minimum distance 20cm between the radiator and your body.