



Shenzhen Shengguang Electronic Technology Co.,LTD

Client DONGGUAN KAFULLE ELECTRONIC CO.LTD

TYPE G50*5.3*1.0; Enamelled Wire 0.08*105p L=40MM

Model NO SG-A11-6.3UH

Part numbering SG-A11-040-001
3L6516

Client p/NO _____

Enginrer NO TOE 1800510003

Date 2024-1-18

For Enginer Departner Only	
Rrvised Content	APPROved Date

Prepared

XieYanQi

Checked

DuanJiaWang

Approved

XieXiaoZai

Authorized Signaturure Company Chop		
Enginrer	QC APPROved	APPROved



一、 Winding Procese:

NO	Winding	Wile	Turns	Direction	Remarks
1	N1	2UEW-B-0.08*105P	10TS	CCW	
2					

二. FEATURES:

1.Test conditions: 25°C,65%RH@100KHz/1V

1.1 Inductance

1.11 L0A (Individual coil) =3.8uH±20%

1.12 L0A(Coil+Ferrite)=6.3uH±10%

1.2 Q=70MIN

1.3 DCR: 60mΩ MAX

1.4 Operating Temperature: -25°C~85°C

2.Test instrument: **L:CH1068+1310;DCR:502BC;SIZE:Callipers**

3.Material List

NO	List	Material
1	WIRE	φ 0.08*105p 2UEW
2	FERRITE	50*5.3*1.0 L
3	GLUE	White Glue
4	SOLDER	XCD-907B
5	Adhesive	双面背胶
6	High temperature adhesive	6MM(Ref)高温胶纸
7		

三. CIRCUIT DIAGRAM

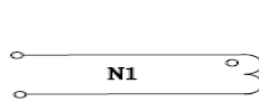
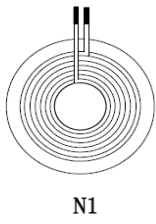

Unit: MM

四. OUTSIDE DIAGRA

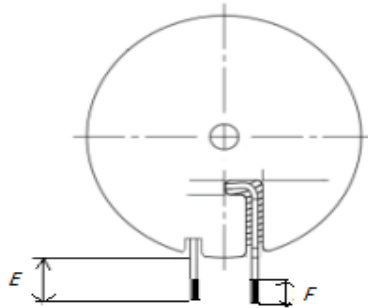
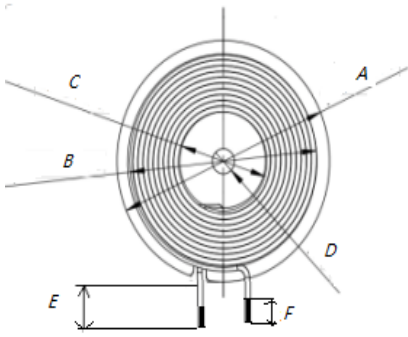

	A	B	C	D	E	F	G	
STD	50±0.5	41.5±1.5	20.5±1.5	5.3±0.5	40±2	2-5	2.8Max	

Unit: MM

五. PACKAGE

5.1 Packing Picture:

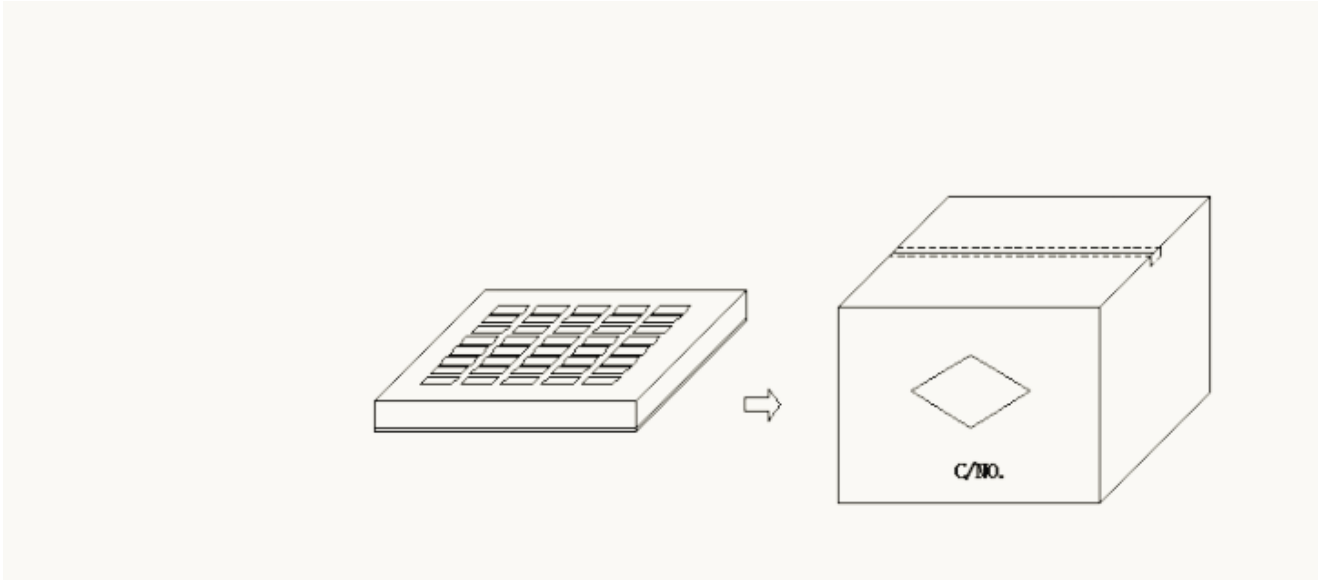

5.2 Packing Quantity

Item	Quantity	Material
Box	350 PCS	345*330*50 MM
Big Carton	1400 PCS	360*340*280 MM

5.3 *The packaging shall be based on the existing packing plate and the actual delivery package shall prevail .If there is any requirement,we can customize it.*



六、 Storage and Use condition

6.1 Storage condition

6.1.1 Recommended keeping conditions: $-25^{\circ}\text{C} \sim 85^{\circ}\text{C}$, 70%RH (Max.)

6.1.2 Storage life: Within the limits of six months from being produced.

6.2 Use condition

Use condition limit: $T=-25^{\circ}\text{C} \sim 85^{\circ}\text{C}$, $\text{RH} \leq 90\%$.