

Thank you for purchasing the Radiomaster ER8 ELRS receiver. The ER8 receiver is based on the revolutionary ExpressLRS system. It offers high performance, high reliability, flexible configuration, fast response speed and ultra-long range bringing you brand new experience with your hobby.

Important:

1. The recommended ELRS LUA settings on the remote-control end are:

- Standard servos:

Packet Rate:	100Hz Full
Telem Ratio:	Std (1:32) (default if unsure)
Switch Mode:	8ch
- Performance servos:

Packet Rate:	333Hz Full
Telem Ratio:	Std (1:28)
Switch Mode:	8ch

- The maximum input voltage for the EXT-V (external voltage input) telemetry reading is 35V. Do not exceed 35V or the receiver will be damaged.
- The EXT-V (external voltage input) of the ER8 is accessed via the EXT-V 2pin JST-GH connector. The RED wire must be soldered to the positive of the battery or ESC. If no EXT-V power source is found, the ER8 will default to reading the voltage on the receiver pins, only one voltage input can be used at the any given time.
- Please ensure that the power supply current of the ESC BEC matches the power consumption requirements of the servo used. If using high-voltage and high-torque servos, it is recommended to use a 2S 7.4V battery for direct power supply or a suitable high-current UBEC.
- Calibration of the telemetry voltage will be required on your radio. Navigate to the telemetry page on your radio and locate the Rx/Bt sensor. Edit the sensor settings and adjust the offset until the displayed reading matches the actual voltage of the battery in the model. If there is a large difference, adjustment of the ratio may also be required.

6: ExpressLRS Arming requirements and the use of Channel 5: CH5 is required by ExpressLRS to set the Arm state of the RF module in your radio. It is recommended to assign CH5 to a switch such as your throttle cut switch as this will provide benefits such as dynamic power. Using the ExpressLRS LUA or the Wifi WebUI, you can assign different channels to the CH5 output of your receiver. See example to the right:

CH1: CH1
CH2: CH2
CH3: CH3
CH4: CH4
CH5: CH9
CH6: CH6
CH7: CH7
CH8: CH8

Please visit <https://www.expresslrs.org/> to learn more on the importance of setting up arming.

The Radiomaster ER8 receiver has been specially designed for fixed-wing users. It can drive up to 8 servos and has built-in receiver voltage telemetry and flight battery telemetry with the ability to automatically detect which voltage input to use. A 4-wire CRSF interface is provided to facilitate later expansion of telemetry sensors. The ER8 features a dual-antenna with telemetry power up to 100mw. The receiver shell adopts one-piece molding process with high structural strength.

Product Features:

- Power supply: DC 3.5 - 8.4V
- Antenna type: 20cm high sensitivity antenna
- Wireless protocol: ExpressLRS 3.2 pre-installed
- Output channel: 8CH PWM
- Telemetry power: maximum 100mw (LUA Adjustable)
- Battery voltage detection range: DC 4.0 - 35V
- Bus interface: CRSF
- Weight: 16.5 grams Size: 43*30*15mm
- Operating Frequency: 2402-2480MHz
- output power: 20dBm max

Firmware:
 Device Category: Radiomaster 2.4Ghz
 Device: RadioMaster ER8 2400 PWM RX

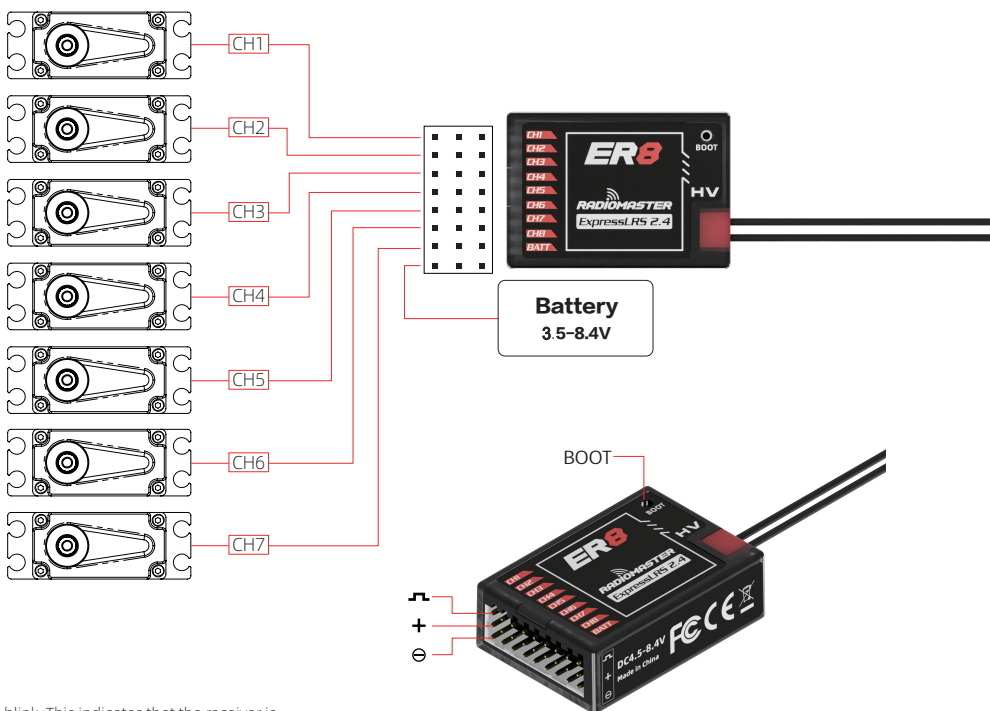

Binding method (traditional):

- The first time you power on your receiver, the LED will double blink. This indicates that the receiver is in bind mode. If this is not the case, hold down the boot button for 10 seconds to reset the receiver.
- Open the ExpressLRS LUA on your remote controller and select [BIND], then confirm.
- A successful bind is indicated by the light being a steady on, indicating that frequency binding was successful.



Note: To bind the receiver a second time or to another radio, power cycle the receiver 3 times. On the third power cycle, the LED will double blink indicating bind mode. If you cannot successfully enter bind mode with the 3 power cycle method, you can hold down the boot button for 10 seconds to reset the receiver to bind mode or use the passphrase method below.

WARNING: All previous settings in the receiver will be erased and need to be set again when using the reset button.

Binding method (P)

- Open the ExpressLRS LUA and navigate to the Wifi Connectivity page. Select the Enable Wifi option and connect to your radios wifi with a mobile phone, tablet or PC (See TX Wifi notes below). Open the WebUI (Express LRS web page on <http://10.0.0.1/>) and choose a unique bind phrase. Note Bind phrases are not secret and can be read. Save and Reboot.
- Power up the receiver and wait 60 seconds for the LED to blink rapidly to indicate Wifi mode. Connect your phone, tablet or PC to the receivers Wifi (See TX Wifi notes below). Open the WebUI (Express LRS web page on <http://10.0.0.1/>) and enter the matching bind phrase previously entered on your radio. Note Bind phrases are not secret and can be read. Save and Reboot. Once a radio and a receiver have the same bind phrase set they will automatically bind.

TX Wifi notes: Wifi default network name: ExpressLRS TX Wifi default password: expresslrs Default URL: http://10.0.0.1/ (Open in browser)	RX Wifi notes: Wifi default network name: ExpressLRS RX Wifi default password: expresslrs Default URL: http://10.0.0.1/ (Open in browser)
------------------------------------------------------------------------------------------------------------------------------------------------------------------------------------------	------------------------------------------------------------------------------------------------------------------------------------------------------------------------------------------

FCC Warning
 This device complies with part 15 of the FCC Rules. Operation is subject to the following two conditions:
 (1) This device may not cause harmful interference, and (2) this device must accept any interference received, including interference that may cause undesired operation.
 Any Changes or modifications not expressly approved by the party responsible for compliance could void the user's authority to operate the equipment.
 Note: This equipment has been tested and found to comply with the limits for a Class B digital device, pursuant to part 15 of the FCC Rules. These limits are designed to provide reasonable protection against harmful interference in a residential installation. This equipment generates uses and can radiate radio frequency energy and, if not installed and used in accordance with the instructions, may cause harmful interference to radio communications. However, there is no guarantee that interference will not occur in a particular installation. If this equipment does cause harmful interference to radio or television reception, which can be determined by turning the equipment off and on, the user is encouraged to try to correct the interference by one or more of the following measures:
 -Reorient or relocate the receiving antenna.
 -Increase the separation between the equipment and receiver.
 -Connect the equipment into an outlet on a circuit different from that to which the receiver is connected.
 -Consult the dealer or an experienced radio/TV technician for help.
 This equipment complies with FCC radiation exposure limits set forth for an uncontrolled environment. This equipment should be installed and operated with minimum distance 20cm between the radiator & your body.

European agent information:
 eVatmaster Consulting GmbH
 Add: Bettinastr. 30,60325 Frankfurt am Main,Germany

Declaration of Conformity
 Shenzhen Radiomaster Co.,Ltd declares that this receiver ER8 is in compliance with the essential requirements and other relevant provisions of Directive 2014/53/EU. In accordance with Article 10(2) and Article 10(10), This product is allowed to be used in all EU member states.