

## TEST REPORT

<b>Report Number</b> .....:	91217-23-72-23-PP001	
<b>Date of issue</b> .....	2023-11-21	
<b>Prepared by (+signature)</b> .....:	Pale	<i>Pale Cai</i>
<b>Reviewer (+signature)</b> .....:	Duke	<i>Duke Chen</i>
<b>Approved by (+signature)</b> .....:	Jason	<i>Jason gao</i>
<b>Testing Laboratory name</b> .....:	SLG-CPC Testlaboratory Co., Ltd.	
<b>Address</b> .....	No. 11, Wu Song Road, Dongcheng District, Dongguan, Guangdong Province, China 523117	
<b>Applicant's name</b> .....:	Dongguan Electric Xiao Er Electronic Technology Co.,LTD	
<b>Address</b> .....	Room 701, Building 1, No.108 Shaxin Road, Tangxia Town, Dongguan City, Guangdong Province, China	
<b>Manufacturer's name</b> .....	Dongguan Electric Xiao Er Electronic Technology Co.,LTD	
<b>Address</b> .....	Room 701, Building 1, No.108 Shaxin Road, Tangxia Town, Dongguan City, Guangdong Province, China	
<b>Factory's name</b> .....	Dongguan Electric Xiao Er Electronic Technology Co.,LTD	
<b>Address</b> .....	Room 701, Building 1, No.108 Shaxin Road, Tangxia Town, Dongguan City, Guangdong Province, China	
<b>Standard(s)</b> .....:	FCC Rules and Regulations Part 15 Subpart C, Section 209	
<b>Test item description</b> .....:	Wireless Charger	
<b>Trade Mark</b> .....:	/	
<b>Model/Type reference</b> .....:	D301	
<b>FCC ID</b> .....:	2BBMP-D301	
<b>Date of receipt of test item</b> .....	2023-11-13	
<b>Date (s) of performance of test:</b>	2023-11-14 to 2023-11-21	
<b>Summary of Test Results</b> .....:	<b>Pass</b>	
The Summary of Test Results based on a technical opinion belongs to the standard(s).		
<b>General disclaimer:</b>		
This report shall not be reproduced except in full, without the written approval of SLG-CPC Testlaboratory Co., Ltd. The test results in the report only apply to the tested sample.		

## TABLE OF CONTENT

<b>TABLE OF CONTENT</b> .....	<b>2</b>
<b>1. SUMMARY OF TEST RESULTS</b> .....	<b>4</b>
<b>2. GENERAL INFORMATION</b> .....	<b>5</b>
2.1. DESCRIPTION OF DEVICE (EUT).....	5
2.2. INDEPENDENT OPERATION MODES .....	6
2.3. DESCRIPTION OF TEST FACILITY .....	6
2.4. DESCRIPTION OF SUPPORT DEVICE .....	7
2.5. MEASUREMENT UNCERTAINTY .....	7
<b>3. MEASURING DEVICE AND TEST EQUIPMENT</b> .....	<b>8</b>
3.1. MEASUREMENT EQUIPMENT USED .....	8
<b>4. 20DB BANDWIDTH</b> .....	<b>8</b>
4.1. TEST PROCEDURE .....	9
4.2. TEST RESULTS.....	9
<b>5. POWER LINE CONDUCTED EMISSION MEASUREMENT</b> .....	<b>11</b>
5.1. BLOCK DIAGRAM OF TEST SETUP .....	11
5.2. LIMITS.....	11
5.3. TEST PROCEDURE .....	11
5.4. MEASURING RESULTS .....	12
<b>6. RADIATED EMISSION TEST</b> .....	<b>13</b>
6.1. MEASUREMENT PROCEDURE .....	15
6.2. TEST SET-UP (BLOCK DIAGRAM OF CONFIGURATION) .....	15
6.3. RADIATED EMISSION LIMIT .....	16
6.4. MEASUREMENT RESULT .....	17
<b>7. ANTENNA APPLICATION</b> .....	<b>17</b>
7.1. ANTENNA REQUIREMENT.....	21
7.2. RESULT .....	21

**Modified Information**

Report No.	Revision Data	Summary
91217-23-72-23-PP001	2023-11-21	Original Version

## 1. SUMMARY OF TEST RESULTS

<b>EMISSION</b>		
Description of Test Item	Standard & Limits	Results
Conducted Emission	FCC Part 15, Subpart C- Section 15.207 ANSI C63.10-2013	Pass
Radiated Emission	FCC Part 15, Subpart C- Section 15.209 ANSI C63.10-2013	Pass
20dB Bandwidth	FCC Part 15, Subpart C- Section 15.215 ANSI C63.10-2013	Pass
Note: N/A is an abbreviation for Not Applicable.		

## 2. GENERAL INFORMATION

### 2.1. Description of Device (EUT)

Product Name	Wireless Charger
Trade Name	/
Model Name	D301
Series Model	/
Output	5W/7.5W/10W for Phone 5W for AirPods 2.5W for Watch
Operation frequency	110-205kHz for Phone and AriPods 326kHz for Watch
Modulation Type	FSK
Antenna Type	Inductive Loop Antenna with 0dBi
Power Supply	Input: DC 9V 2A
Hardware version number	A2
Software version number	0x004EF0F5
Connecting I/O Port(s)	Please refer to the User's Manual

## 2.2. Independent Operation Modes

Mode:	TEST MODE DESCRIPTION
1	EUT + Wireless Output: 10W for Phone + Wireless Output: 5W for AirPods + Wireless Output: 2.5W for Watch
2	EUT + Wireless Output: 7.5W for Phone + Wireless Output: 5W for AirPods + Wireless Output: 2.5W for Watch
3	EUT + Wireless Output: 5W for Phone + Wireless Output: 5W for AirPods + Wireless Output: 2.5W for Watch
4	EUT + Wireless Output: 10W for Phone + Wireless Output: 5W for AirPods
5	EUT + Wireless Output: 10W for Phone + Wireless Output: 2.5W for Watch
6	EUT + Wireless Output: 7.5W for Phone + Wireless Output: 5W for AirPods
7	EUT + Wireless Output: 7.5W for Phone + Wireless Output: 2.5W for Watch
8	EUT + Wireless Output: 5W for Phone + Wireless Output: 5W for AirPods
9	EUT + Wireless Output: 5W for Phone + Wireless Output: 2.5W for Watch
10	EUT + Wireless Output: 5W for AirPods + Wireless Output: 2.5W for Watch
11	EUT + Wireless Output: 10W for Phone
12	EUT + Wireless Output: 7.5W for Phone
13	EUT + Wireless Output: 5W for Phone
14	EUT + Wireless Output: 5W for AirPods
15	EUT + Wireless Output: 2.5W for Watch
16	EUT + Wireless Output: 2.5W for Watch
Note: 1. All test modes were pre - tested, but we only recorded the worst case in this report. The worst case is Mode 1 2. All voltage inputs have been tested, with only the worst voltage recorded. 3. Product folding has been evaluated for use.	

## 2.3. Description of Test Facility

### Site Description

EMC Lab. : Accredited by ISED, October 31 2023  
 CAB identifier: CN0126  
 Company Number: 27767

Accredited by A2LA, October 31 2023  
 The Certificate Registration Number is 6325.01

Accredited by FCC  
 Designation Number: CN1287  
 Test Firm Registration Number: 394054

Name of Firm : SLG-CPC Testlaboratory Co., Ltd.  
 Site Location : No. 11, Wu Song Road, Dongcheng District, Dongguan, Guangdong Province, China 523117

### Description of Support Device

No.	Equipment	Trade name	Model	S/N	Power Cord
1.	Cellphone	Apple	IPhone12pro max		
2	Adapter	/	HW-200675CD1		
3	Watch	Apple	S8		
4	Earbuds	Apple	A2190		

### 2.4. Measurement Uncertainty

Test Item	Uncertainty
Occupied Channel Bandwidth	: $\pm 2.3\%$
Conducted Emission Uncertainty	: 3.08dB
Radiated Emission Uncertainty	:
(3m Chamber)	3.46dB (0.009MHz~30MHz)
	3.60dB (30MHz~1GHz)
	4.48dB (1~6GHz)

### 3. MEASURING DEVICE AND TEST EQUIPMENT

#### 3.1. MEASUREMENT EQUIPMENT USED

Equipment	Manufacturer	Model	S/N	Last Cal.	DUE Cal.
<b>RF Connected Test</b>					
Vector Signal Generator	Rohde & Schwarz	SMBV100B(6G)	101166	2023/06/04	1 year
Analog Signal Generator	Rohde & Schwarz	SMB100A(40G)	181333	2023/08/04	1 year
Signal Analyzer	Rohde & Schwarz	FSV40	101527	2023/03/29	1 year
Power Analyzer	Rohde & Schwarz	OSP-B157W8	N/A	2023/06/02	1 year
Wideband Radio Communication Tester	R&S	CMW270	101985	2023/06/16	1 year
Wideband Radio Communication Tester	Rohde & Schwarz	CMW500	166898	2023/06/16	1 year
Temperature&Humidity test chamber	ESPEC	VC 4018	/	2023/03/29	1 year
<b>Radiated Emission Test</b>					
EMI Test Receiver	KEYSIGHT	N9010A	MY56070465	2022/12/07	1 year
EMI Test Receiver	Rohde & Schwarz	FSV40	101511	2023/03/29	1 year
Bilog Antenna	Schwarzbeck	VULB 9163	01335	2023/04/21	3 year
Broadband Antenna	Schwarzbeck	9162	139	2022/03/22	3 year
Power Amplifier	EMEC	EM330	060676	2022/12/07	3 year
Cable	Tuyue	F4309	L-400-NmNm-12000	2022/12/07	1 year
Horn Antenna	Schwarzbeck	BBHA9120D	1779	2022/04/21	3 year
Horn Antenna	Schwarzbeck	BBHA9170	00954	2022/09/13	3 year
Power Amplifier	Rohde & Schwarz	SCU-18F	180118	2022/04/21	3 year
Power Amplifier	Rohde & Schwarz	SCU40A	100499	2023/06/21	3 year
Active Loop Antenna	ETS LINDGREN	6512	41623	2022/04/23	3 year
Test Software	Farad	EZ-EMC	Ver.CPC-3A1	/	/
<b>Conducted Emission Test</b>					
LISN	Schwarzbeck	NSLK 8127	8127-892	2023/03/21	1 year
LISN	Schwarzbeck	NSLK 8127	8127-437	2023/07/07	1 year
EMI Test Receiver	R&S	ESR3	102124	2022/12/07	1 year
Triple loop	R&S	HM020	834206/006	2022/12/07	2 year
Pulse Limiter	R&S	ESH3-Z2	357.8810.52	2022/12/07	1 year
Test Software	Farad	EZ-EMC	Ver.CPC-3A1	/	/





Frequency 110-205kHz 20dB Band=973Hz

For AirPods

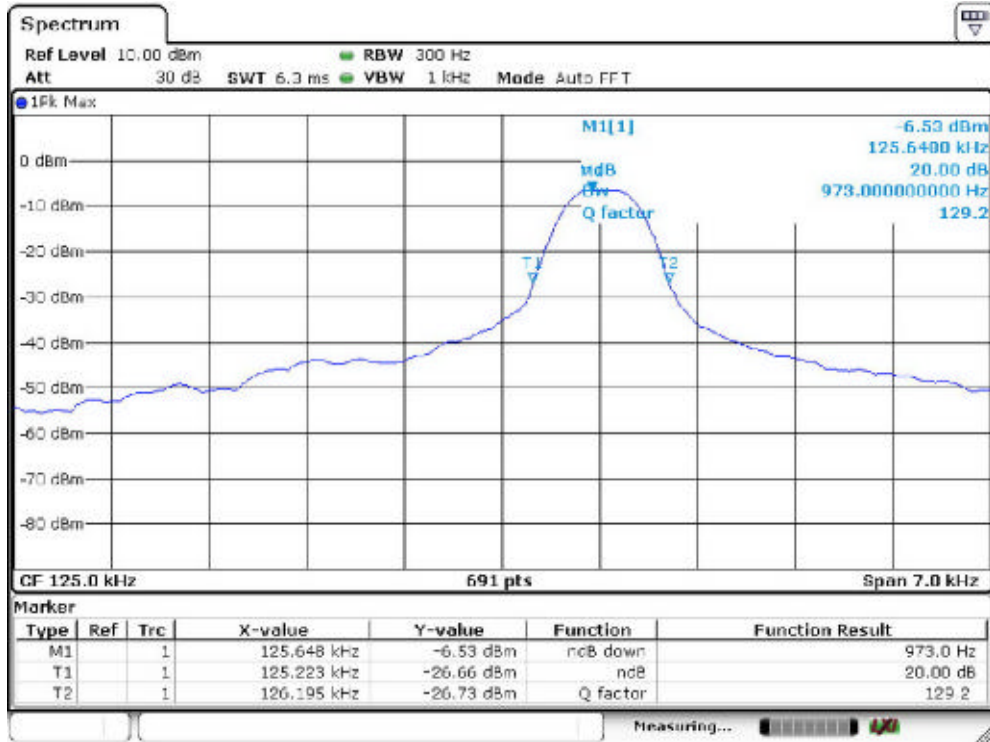

Frequency 326kHz 20dB Band=861kHz

For Watch

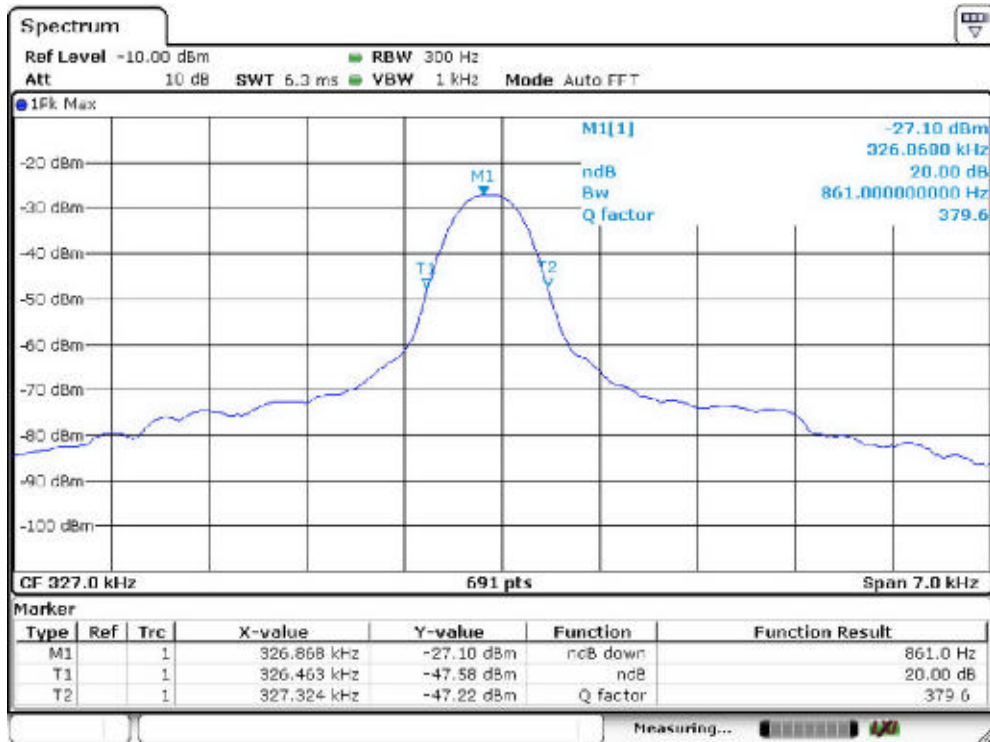

## 5. POWER LINE CONDUCTED EMISSION MEASUREMENT

### 5.1. Block Diagram of Test Setup

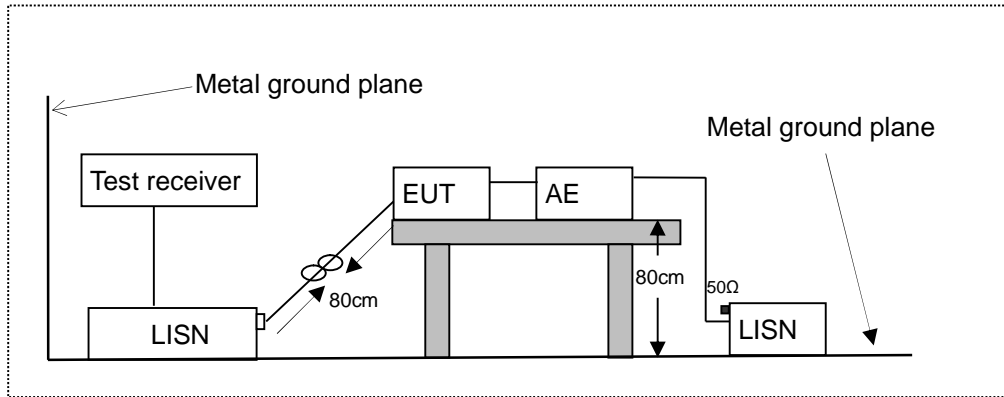

LISN: Line Impedance Stabilization Network  
 AE: Associated equipment  
 EUT: Equipment under test

### 5.2. Limits

FCC Part 15.207

Frequency (MHz)	Limit (dB $\mu$ V)	
	Quasi-peak Level	Average Level
0.15 ~ 0.50	66.0 ~ 56.0 *	56.0 ~ 46.0 *
0.50 ~ 5.00	56.0	46.0
5.00 ~ 30.00	60.0	50.0

NOTE1-The lower limit shall apply at the transition frequencies.  
 NOTE2-The limit decreases linearly with the logarithm of the frequency in the range 0.15MHz to 0.50MHz.

### 5.3. Test Procedure

The EUT was placed on a desk 0.8 m height from the metal ground plane and 0.4 m from the conducting wall of the shielding room and it was kept at least 0.8 m from any other grounded conducting surface. The size of the table will nominally be 1.5 m x1.0 m.

The rear of the arrangement shall be flush with the back of the supporting tabletop unless that would not be possible or typical of normal use.

All units of equipment forming the system under test (includes the EUT as well as connected peripherals and associated equipment or devices) shall be arranged such that a nominal 0.1 m separation is achieved between the neighboring units.

Connect EUT to the power mains through a line impedance stabilization network (LISN). Where the mains cable supplied by the manufacturer is longer than 1 m, the excess should be folded at the centre into a bundle no longer than 0.4 m, so that its length is shortened to 1 m.

All the support units are connecting to the other LISN.

The LISN provides 50 ohm coupling impedance for the measuring instrument.

Both sides of AC line were checked for maximum conducted interference.

The frequency range from 150 kHz to 30 MHz was sweep.

Set the test-receiver system to quasi peak detect function and average detect function, and to measure the conducted emissions values.

Test results were obtained from the following equation:

Emission Level (dB $\mu$ V) = LISN Factor (dB) + Cable Loss (dB) + Reading (dB $\mu$ V)

Margin (dB) = Emission Level (dB $\mu$ V) - Limit (dB $\mu$ V)

#### 5.4. Measuring Results

**PASS.**

Model No.:	D301
Phase:	L1
Test Power :	AC 120V/60Hz
Standard:	FCC Part15C Conduction(QP)
Operating Mode :	Mode 1
Temperature:	24°C
Humidity:	53 %

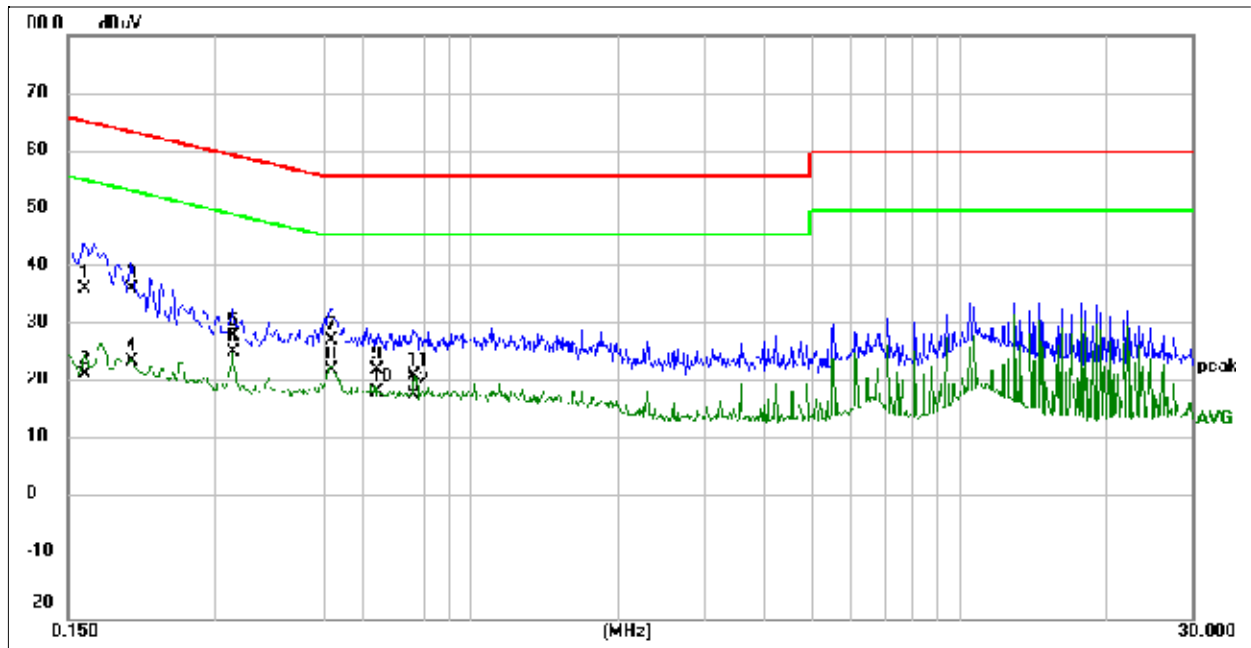

No.	Frequency (MHz)	Reading Level (dBuV)	Correct Factor (dB/m)	Emission Level (dBuV/m)	Limit (dBuV/m)	Margin (dB)	Detector	Comment
1	0.1620	16.27	20.27	36.54	65.36	-28.82	QP	
2	0.1620	1.75	20.27	22.02	55.36	-33.34	AVG	
3	0.2020	14.82	21.81	36.63	63.53	-26.90	QP	
4	0.2020	2.62	21.81	24.43	53.53	-29.10	AVG	
5	0.3260	6.69	21.88	28.57	59.55	-30.98	QP	
6	0.3260	3.99	21.88	25.87	49.55	-23.68	AVG	
7	0.5180	6.00	21.89	27.89	56.00	-28.11	QP	
8	0.5180	1.07	21.89	22.96	46.00	-23.04	AVG	
9	0.6419	1.00	21.89	22.89	56.00	-33.11	QP	
10	0.6419	-2.74	21.89	19.15	46.00	-26.85	AVG	
11	0.7620	0.04	21.88	21.92	56.00	-34.08	QP	
12	0.7620	-3.27	21.88	18.61	46.00	-27.39	AVG	

Model No.:	D301
Phase:	N
Test Power :	AC 120V/60Hz
Standard:	FCC Part15C Conduction(QP)
Operating Mode :	Mode 1
Temperature:	24°C
Humidity:	53 %

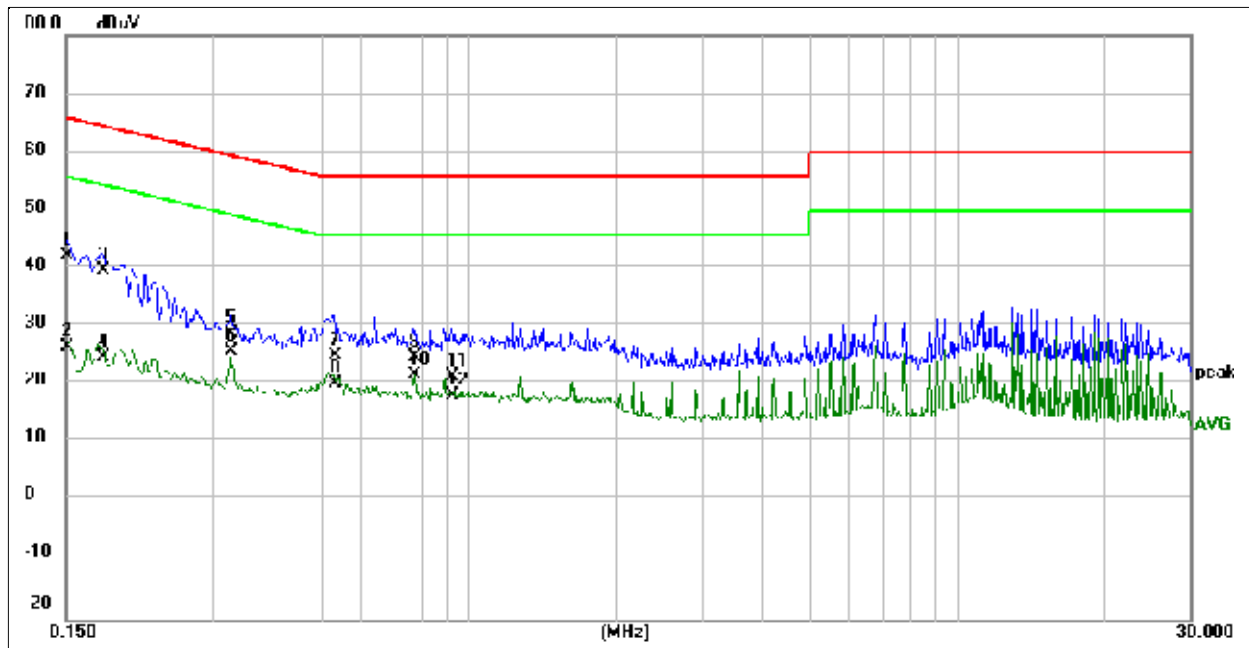

No.	Frequency (MHz)	Reading Level (dBuV)	Correct Factor (dB/m)	Emission Level (dBuV/m)	Limit (dBuV/m)	Margin (dB)	Detector	Comment
1	0.1500	22.52	19.98	42.50	66.00	-23.50	QP	
2	0.1500	6.78	19.98	26.76	56.00	-29.24	AVG	
3	0.1780	18.75	21.08	39.83	64.58	-24.75	QP	
4	0.1780	4.08	21.08	25.16	54.58	-29.42	AVG	
5	0.3260	7.25	21.88	29.13	59.55	-30.42	QP	
6	0.3260	4.19	21.88	26.07	49.55	-23.48	AVG	
7	0.5299	3.44	21.89	25.33	56.00	-30.67	QP	
8	0.5299	-1.33	21.89	20.56	46.00	-25.44	AVG	
9	0.7740	3.32	21.88	25.20	56.00	-30.80	QP	
10	0.7740	0.30	21.88	22.18	46.00	-23.82	AVG	
11	0.9260	-0.05	21.88	21.83	56.00	-34.17	QP	
12	0.9260	-3.33	21.88	18.55	46.00	-27.45	AVG	

## 6. RADIATED EMISSION TEST

### 6.1. Measurement Procedure

1. The EUT was placed on a turn table which is 0.8m above ground plane.
2. Maximum procedure was performed on the six highest emissions to ensure EUT compliance.
3. And also, each emission was to be maximized by changing the polarization of receiving antenna both horizontal and vertical.
4. Repeat above procedures until all frequency measured were complete.
5. Use the following receiver/spectrum analyzer settings:  
 Span = wide enough to fully capture the emission being measured  
 RBW=200Hz for 9KHz to 150KHz,  
 RBW=9kHz for 150KHz to 30MHz,  
 RBW=120KHz for 30MHz to 1GHz  
 VBW  $\geq$  3\*RBW  
 Sweep = auto  
 Detector function = QP  
 Trace = max hold

### 6.2. Test SET-UP (Block Diagram of Configuration)

(A) Radiated Emission Test Set-Up, Frequency Below 30MHz

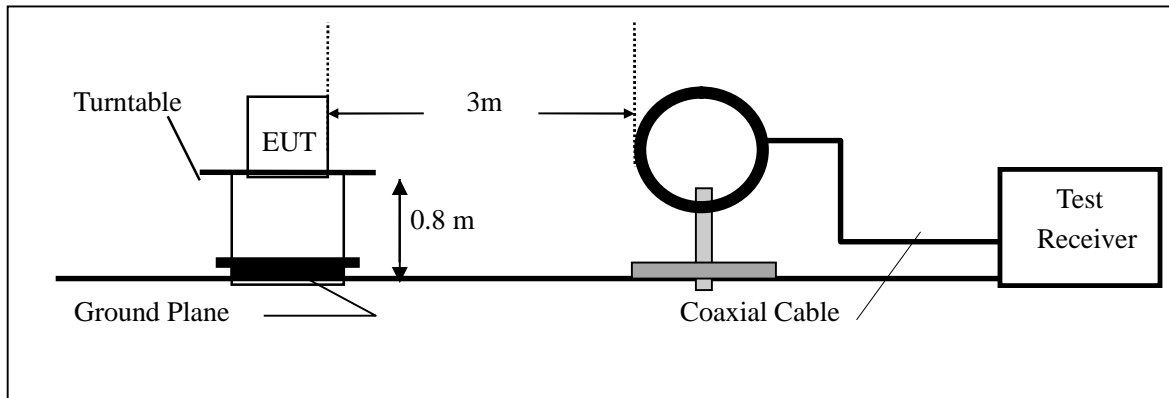

(B) Radiated Emission Test Set-Up, Frequency Below 1000MHz

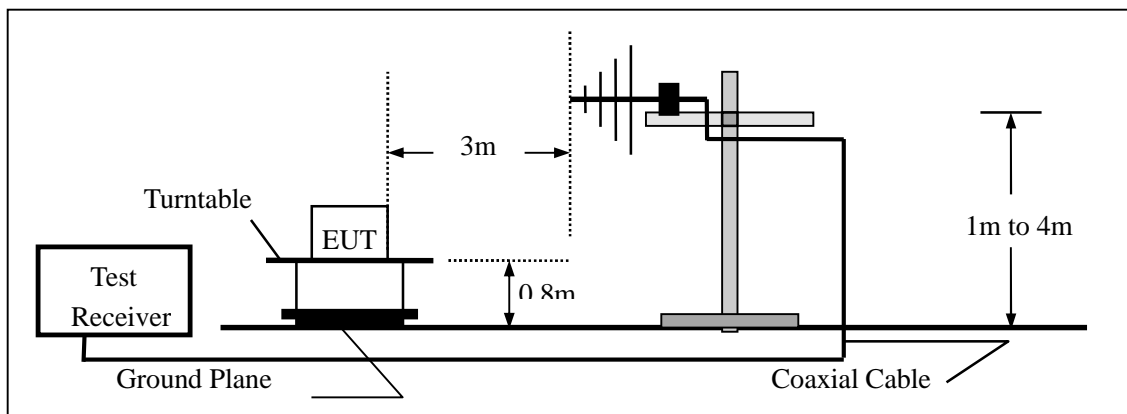

### 6.3. Radiated Emission Limit

The emissions from an intentional radiator shall not exceed the field strength levels specified in the following table 15.209(a):

FCC Part 15.209				
Frequency (MHz)	Field Strength Limitation		Field Strength Limitation Frequency tion at 3m Measurement Dist	
	(uV/m)	Dist	(uV/m)	(dBuV/m)
0.009 – 0.490	2400 / F(KHz)	300m	10000 * 2400/F(KHz)	20log 2400/F(KHz) + 80
0.490 – 1.705	24000 / F(KHz)	30m	100 * 24000/F(KHz)	20log 24000/F(KHz) + 40
1.705 – 30.00	30	30m	100* 30	20log 30 + 40
30.0 – 88.0	100	3m	100	20log 100
88.0 – 216.0	150	3m	150	20log 150
216.0 – 960.0	200	3m	200	20log 200
Above 960.0	500	3m	500	20log 500

#### 15.205 Restricted bands of operation

MHz	MHz	MHz	GHz
0.090 - 0.110	16.42 - 16.423	399.9 - 410	4.5 - 5.15
<sup>1</sup> 0.495 - 0.505	16.69475 - 16.69525	608 - 614	5.35 - 5.46
2.1735 - 2.1905	16.80425 - 16.80475	960 - 1240	7.25 - 7.75
4.125 - 4.128	25.5 - 25.67	1300 - 1427	8.025 - 8.5
4.17725 - 4.17775	37.5 - 38.25	1435 - 1626.5	9.0 - 9.2
4.20725 - 4.20775	73 - 74.6	1645.5 - 1646.5	9.3 - 9.5
6.215 - 6.218	74.8 - 75.2	1660 - 1710	10.6 - 12.7
6.26775 - 6.26825	108 - 121.94	1718.8 - 1722.2	13.25 - 13.4
6.31175 - 6.31225	123 - 138	2200 - 2300	14.47 - 14.5
8.291 - 8.294	149.9 - 150.05	2310 - 2390	15.35 - 16.2
8.362 - 8.366	156.52475 - 156.52525	2483.5 - 2500	17.7 - 21.4
8.37625 - 8.38675	156.7 - 156.9	2690 - 2900	22.01 - 23.12
8.41425 - 8.41475	162.0125 - 167.17	3260 - 3267	23.6 - 24.0
12.29 - 12.293	167.72 - 173.2	3332 - 3339	31.2 - 31.8
12.51975 - 12.52025	240 - 285	3345.8 - 3358	36.43 - 36.5
12.57675 - 12.57725	322 - 335.4	3600 - 4400	( <sup>2</sup> )

- Remark:
1. Emission level in dBuV/m=20 log (uV/m)
  2. Measurement was performed at an antenna to the closed point of EUT distance of meters.
  3. Only spurious frequency is permitted to locate within the Restricted Bands specified in provision of  $\xi$  15.205, and the emissions located in restricted bands also comply with 15.209 limit.



### 6.4.Measurement Result

9kHz-150kHz:

Model No.:	D301
Phase:	Vertical
Test Power :	AC 120V/60Hz
Standard:	FCC Part15.209 9k-30M
Operating Mode :	Mode 1
Temperature:	24°C
Humidity:	51%

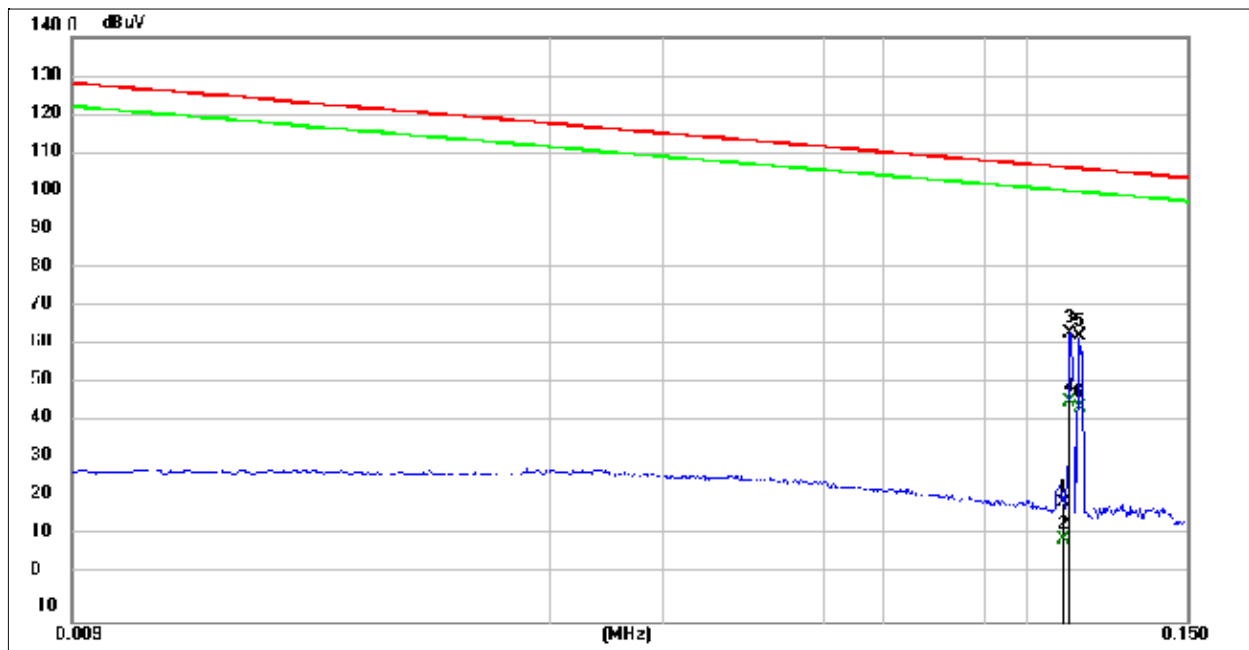

No.	Frequency (MHz)	Reading Level (dBuV)	Correct Factor (dB/m)	Emission Level (dBuV/m)	Limit (dBuV/m)	Margin (dB)	Remark
1	0.111600	80.83	-22.76	58.07	106.64	-48.57	peak
2	0.111600	72.12	-22.76	49.36	106.64	-57.28	AVG
3	0.115500	79.76	-22.75	57.01	106.35	-49.34	peak
4	0.115500	69.92	-22.75	47.17	106.35	-59.18	AVG

#### Restricted band edge

Frequency (Khz)	Reading Level (dBuV/m)	Factor (dB/m)	Emission level (dBuv/m)	Limit (dBuV/m)	Detector Type	Result
0.110000	40.90	-22.76	18.14	106.77	PK	PASS
0.110000	33.99	-22.76	11.23	106.77	AV	PASS

150kHz-30MHz:

Model No.:	D301
Phase:	Vertical
Test Power :	AC 120V/60Hz
Standard:	FCC Part15.209 9k-30M
Operating Mode :	Mode 1
Temperature:	24℃
Humidity:	51%

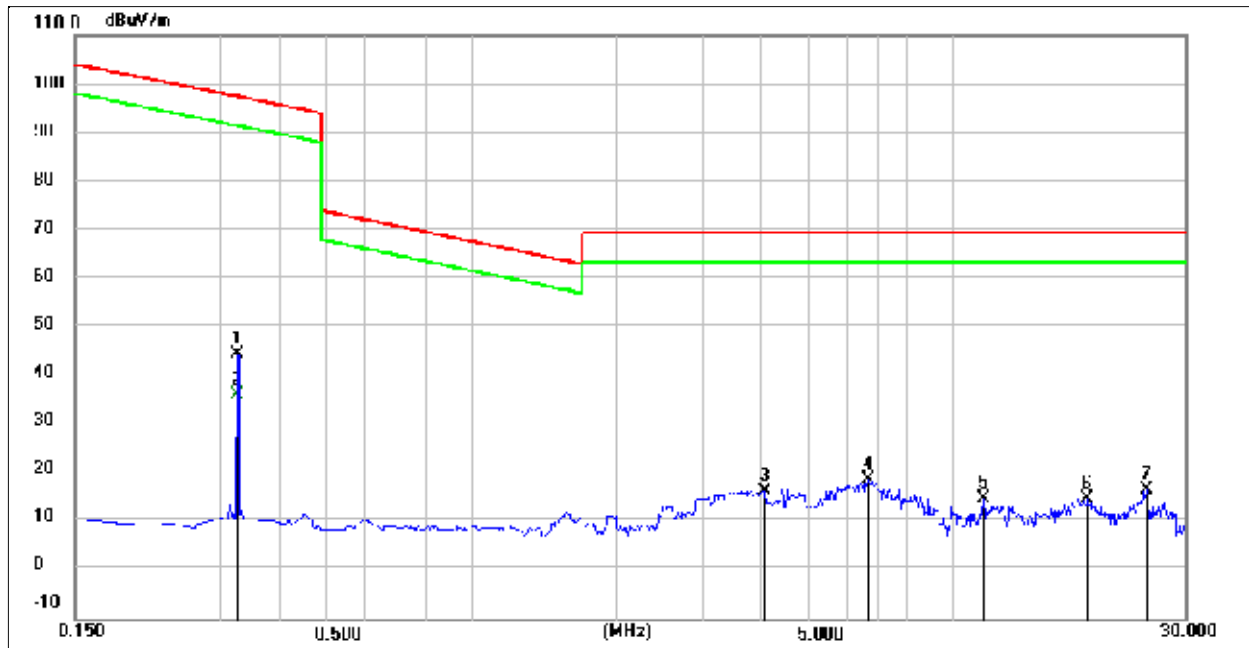

No.	Frequency (MHz)	Reading Level (dBuV)	Correct Factor (dB/m)	Emission Level (dBuV/m)	Limit (dBuV/m)	Margin (dB)	Remark
1	0.326200	67.38	-22.68	44.70	97.47	-52.77	peak
2	0.326200	58.86	-22.68	36.18	97.47	-61.29	AVG
3	4.060200	38.77	-22.27	16.50	69.50	-53.00	peak
4	6.627200	40.49	-21.74	18.75	69.50	-50.75	peak
5	11.463100	35.88	-20.96	14.92	69.50	-54.58	peak
6	18.865800	34.18	-19.11	15.07	69.50	-54.43	peak
7	24.955300	36.34	-19.69	16.65	69.50	-52.85	peak

30MHz-1GHz:

Model No.:	D301
Phase:	Vertical
Test Power :	AC 120V/60Hz
Standard:	FCC Part15C Radiation(QP)
Operating Mode :	Mode 1
Temperature:	22°C
Humidity:	53%

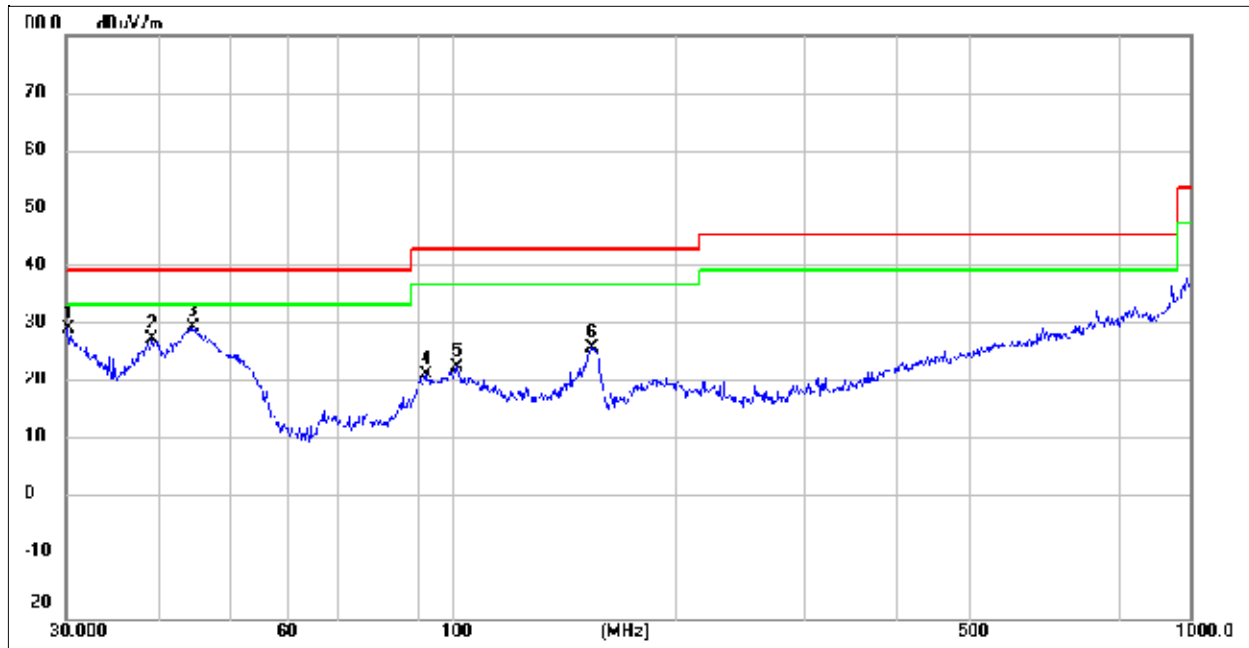

No.	Frequency (MHz)	Reading Level (dBuV)	Correct Factor (dB/m)	Emission Level (dBuV/m)	Limit (dBuV/m)	Margin (dB)	Remark			
1	30.1054	27.71	2.24	29.95	40.00	-10.05	QP			
2	39.1616	31.28	-3.20	28.08	40.00	-11.92	QP			
3	44.5868	35.00	-4.82	30.18	40.00	-9.82	QP			
4	92.1388	30.86	-8.65	22.21	43.50	-21.29	QP			
5	101.6443	31.24	-8.01	23.23	43.50	-20.27	QP			
6	154.2786	35.19	-8.47	26.72	43.50	-16.78	QP			

Model No.:	D301
Phase:	Horizontal
Test Power :	AC 120V/60Hz
Standard:	FCC Part15C Radiation(QP)
Operating Mode :	Mode 1
Temperature:	22°C
Humidity:	53%

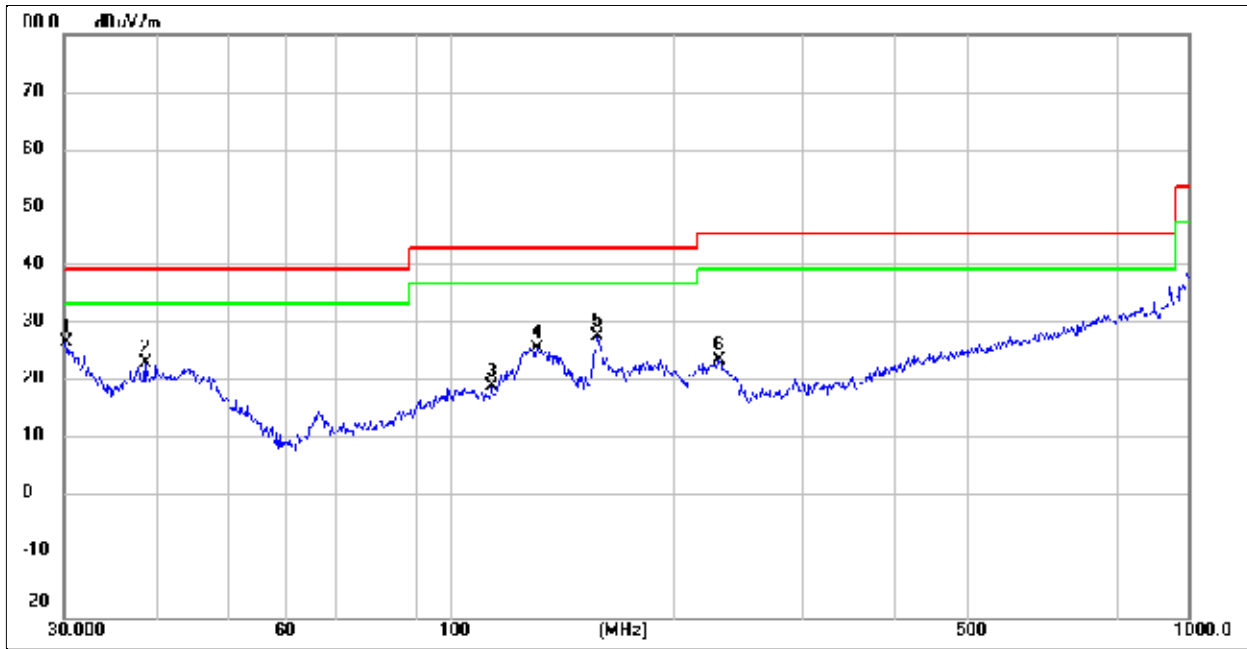

No.	Frequency (MHz)	Reading Level (dBuV)	Correct Factor (dB/m)	Emission Level (dBuV/m)	Limit (dBuV/m)	Margin (dB)	Remark			
1	30.1054	25.06	2.24	27.30	40.00	-12.70	QP			
2	38.6160	27.06	-3.31	23.75	40.00	-16.25	QP			
3	113.7143	28.66	-8.81	19.85	43.50	-23.65	QP			
4	131.2965	34.54	-8.19	26.35	43.50	-17.15	QP			
5	158.1123	36.81	-8.47	28.34	43.50	-15.16	QP			
6	230.9068	33.00	-8.54	24.46	46.00	-21.54	QP			

## 7. ANTENNA APPLICATION

### 7.1. Antenna Requirement

Standard	Requirement
FCC CRF Part 15.203	<p>An intentional radiator shall be designed to ensure that no antenna other than that furnished by the responsible party shall be used with the device. The use of a permanently attached antenna or of an antenna that uses a unique coupling to the intentional radiator shall be considered sufficient to comply with the provisions of this section. The manufacturer may design the unit so that a broken antenna can be replaced by the user, but the use of a standard antenna jack or electrical connector is prohibited. This requirement does not apply to carrier current devices or to devices operated under the provisions of §15.211, §15.213, §15.217, §15.219, or §15.221. Further, this requirement does not apply to intentional radiators that must be professionally installed, such as perimeter protection systems and some field disturbance sensors, or to other intentional radiators which, in accordance with §15.31(d), must be measured at the installation site. However, the installer shall be responsible for ensuring that the proper antenna is employed so that the limits in this part are not exceeded.</p>

For intentional device, according to FCC 47 CFR Section 15.203, an intentional radiator shall be designed to ensure that no antenna other than that furnished by the responsible party shall be used with the device.

### 7.2. Result

PASS.

The EUT has 3 antennas: an Inductive Loop Antenna, antenna has a gain of 0 dBi;

- Note:
- Antenna use a permanently attached antenna which is not replaceable.
  - Not using a standard antenna jack or electrical connector for antenna replacement
  - The antenna has to be professionally installed (please provide method of installation)

which in accordance to section 15.203, please refer to the internal photos.

-----The end-----