

Customer: EG112

## SPECIFICATION FOR APPROVAL

Customer P/N	9-083-2205001		
Description	Multi-coil Wireless Charging		
Drawing No.			
3L P/N	WPT945404-120K-A13C		
Date	20220520	Rev.	XC
Customer	Approved For Customer		
Seller	Drawn	Checked	Approved
	LIUYAN	BAKER	HE HONG

Please Return After Approving



Headquarters : 3L ELECTRONIC (ZHONG SHAN) CORP.

URL : <http://www.3lcoil.com>

ADD : No 6 Industrial Park Nanlang Town Zhong Shan Guangdong,P.R.China



Customer:	EG112	Customer P/N:	9-083-2205001
-----------	-------	---------------	---------------

1. Mechanical Dimension(mm) :

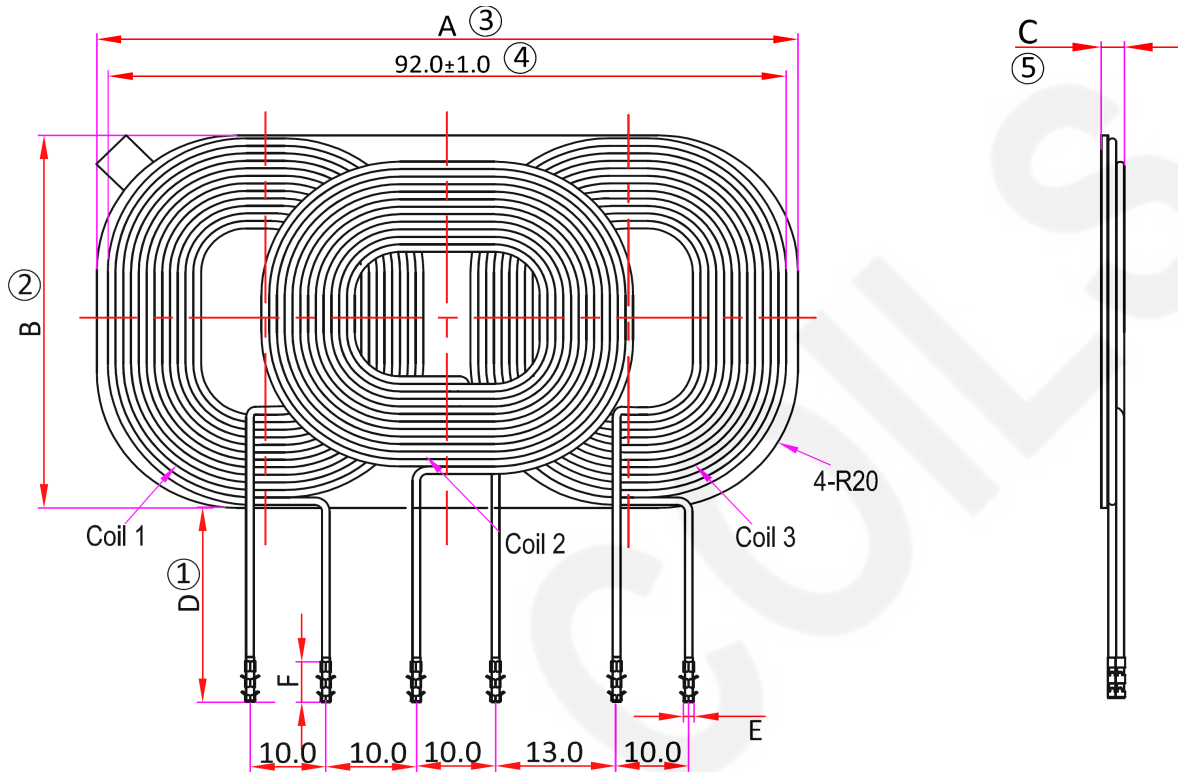

ITEM	SPEC(mm)	TYP(mm)	ITEM	SPEC(mm)	TYP(mm)
A	94.0+-1.2		F	6.35+-1.0	6.35
B	54.0+-0.8	53.9	G		
C	3.8 MAX	3.5	H		
D	18.0+-1.0	18.2	I		
E	1.75REF	1.86	J		

Note:

1. Core peeling & breakage: Breakage is acceptable when it meets: length ≤ 5mm, width ≤ 1mm, depth ≤ 0.5mm. Every two breakages within 1mm interval would be regarded as one breakage and three breakages under this standard shall be acceptable on each product.
2. Crack on core: No more than two unobvious cracks which is less than 5mm long and 0.5mm wide are allowable to be on the core. Any crack or coating detachment affecting electromagnetic performance of core or mechanical strength is not acceptable.
3. Core fatness of product surface: The acceptable height difference of uneven surface shall be ≤ 0.03mm.
4. Dislocation of PET film and double-sided adhesive tape: The PET film shall not exceed outward the core more than 0.5mm and not be 1.0mm less than the core inward.

3L P/N:	WPT945404-120K-A13C	Rev.	XC	Date:	20220520
---------	---------------------	------	----	-------	----------

<b>Customer:</b> EG112	<b>Customer P/N:</b> 9-083-2205001
------------------------	------------------------------------

5. PET film cleaning: 1) No folding on the PET. 2) No more than 3 bubbles on single side of film while the area of single bubble shall not be more than 2mm.
6. Double-sided adhesive tape cleaning: 1) No folding on the tape. 2) No more than 3 bubbles on single side of tape while the area of single bubble shall not be more than 2mm.No breakage or hurt on tape.
7. "C" size isn't separate paper.
8. Coils no visible enameled wire is allowed in the product (0.6mm<sup>2</sup> MAX single face), except for the tin-impregnated damaged parts.
9. At the upper limit of the coil, the length direction allows the coil to exceed 0.6 mm max of the coil.
- 10."o"---- is KPC size, "C" size does not contain release paper.
11. Pin spacing tolerance is +-.3.0, measured at coil root prevail

## 1.2 Hardening Dimensions : ( Coil Pin tinned )

浸锡折弯后发硬高度为5.5mmMAX

浸锡的上限位至可折弯的下限位 范围

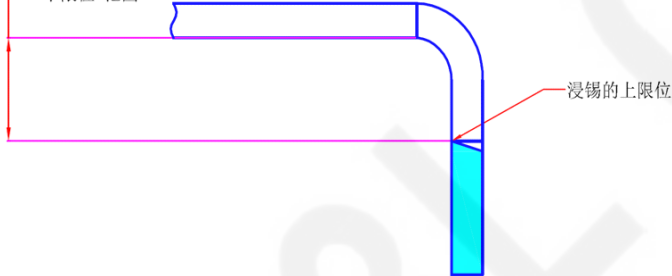

F 1.0-1.5kg 受力在不断引线下可调整

受力后发硬高度为4.5mmMAX

浸锡的上限位至可折弯的下限位 范围

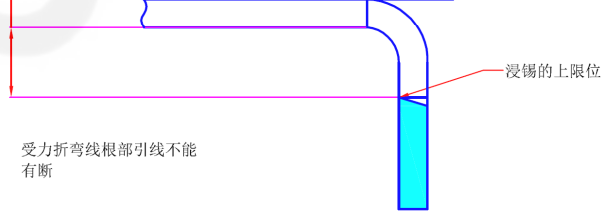

## 1.3 Coils Size

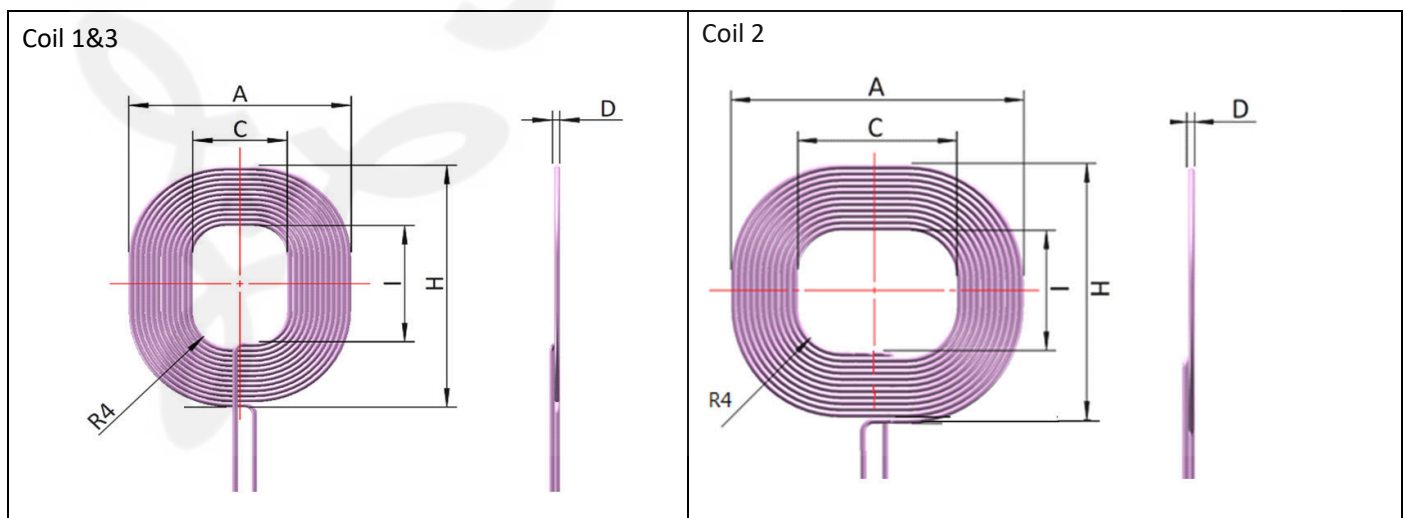

<b>3L P/N:</b> WPT945404-120K-A13C	<b>Rev.:</b> XC	<b>Date:</b> 20220520
------------------------------------	-----------------	-----------------------

<b>Customer:</b>	EG112	<b>Customer P/N:</b>	9-083-2205001
------------------	-------	----------------------	---------------

A	45.2±0.6	A	53.2±0.6
C	19.5±0.5	C	27.5±0.5
D	1.25±0.15	D	1.25±0.15
H	53.2±0.6	H	45.2±0.6
I	27.5±0.5	I	19.5±0.5

**2. Coil unit Assembly :**

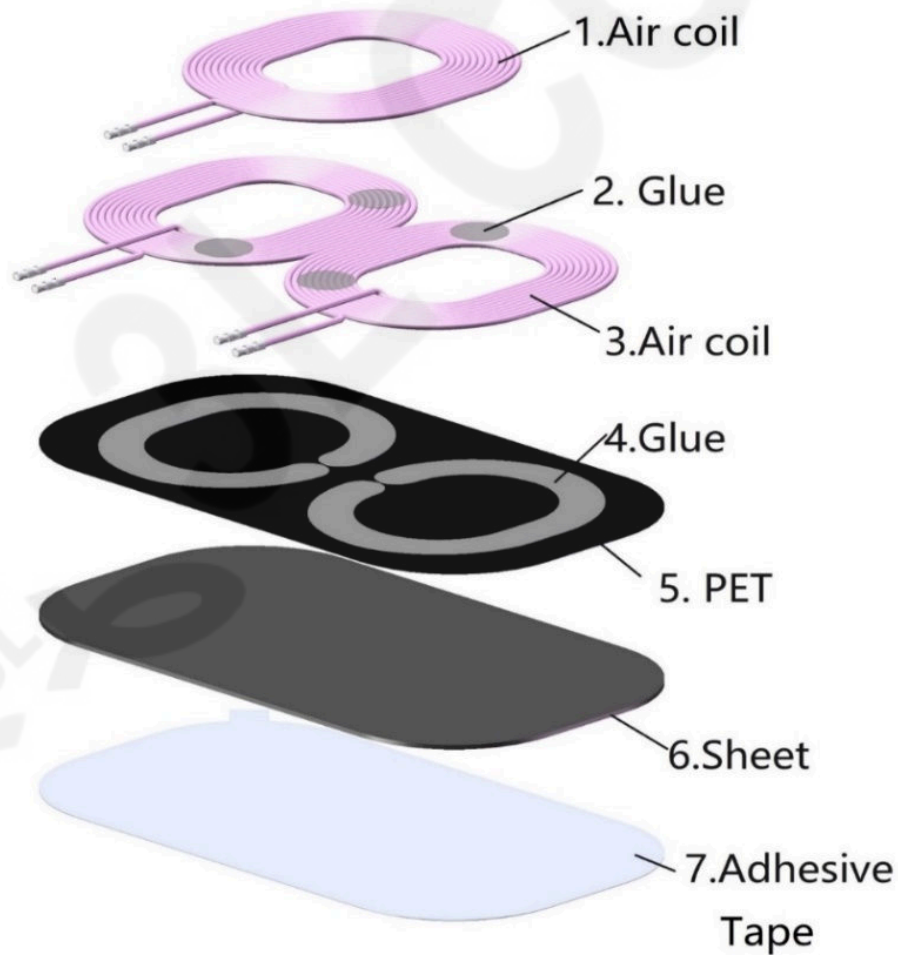

<b>3L P/N:</b>	WPT945404-120K-A13C	<b>Rev.</b>	XC	<b>Date:</b>	20220520
----------------	---------------------	-------------	----	--------------	----------

<b>Customer:</b>	EG112	<b>Customer P/N:</b>	9-083-2205001
------------------	-------	----------------------	---------------

### 3. Electrical Characteristics (at 25°C / RH 65% unless otherwise specified) :

Test Item	Specification	Test Condition	Test Instrument
L1; L3	12.5uH±10%	100KHz 1.0V	HP4284A PRECISION LCR METER
L2	11.5uH±10%	100KHz 1.0V	HP4284A PRECISION LCR METER
Q1 2 3	70 MIN	100KHz 1.0V	HP4284A PRECISION LCR METER
DCR1; DCR3	65 m Ω MAX		CHENHWA 502 OHM METER
DCR2	65 m Ω MAX		CHENHWA 502 OHM METER
L1=L3 TURNS	12TS ∅ 0.08X105P		
L2 TURNS	12TS ∅ 0.08X105P		
Ope.Temp	-40 TO 105°C		HC-D3M TEMP. & HUMIDITY CHAMBER
Weight			

#### Note:

The operating temperature is only for the electrical and structural performance of the inductive product.

Back glue: 3M 9448

### 4. Material list :

No.	Material	Description	Manufacturer	UL No.& Rating
1	CORE	94/54 ui3300	YUYI/JINHE/ EQUATES.	N/A
2	WIRE	∅ 0.08X105P (热风自粘线, 不含丙酮) 2UEW-F/HE UDTC /155°C	HUAYE/WEIHAN	E345710 155°C
3	GLUE	S133-4C/SE5110	E-Linking/Equates	N/A
4	SOLDER	Sn99.9	TONGFANG	N/A
5	TAPE	9448A	3M	N/A
6	TAPE PET	FP-50H	KUNSHAN RICH&CROWN EELTRONIC MATERIALSS CO.,LTD	N/A
7	CLIP	B1820	JWT	N/A

<b>3L P/N:</b>	<b>WPT945404-120K-A13C</b>	<b>Rev.</b>	XC	<b>Date:</b>	20220520
----------------	----------------------------	-------------	----	--------------	----------

<b>Customer:</b>	EG112	<b>Customer P/N:</b>	9-083-2205001
------------------	-------	----------------------	---------------

#### 4.1 Core main characteristics

NO.	Parameters	Code	Unit	Test condition	BP95	
1	Initial permeability	$\mu_i$		25°C	3300±20%	
2	Saturation flux density	Bs	mT	H=1194A/m	25°C	510
					100°C	390
4	Pcv Power Loss	Pc	kw/m <sup>3</sup>	25°C, 100kHz, 200mT	450	
				100°C, 100kHz, 200mT	380	
5	Curie temperature	Tc	°C		≥215	
6	Density	D	kg/m <sup>3</sup>		4.8×10 <sup>3</sup>	

#### 4.2 Core material Characteristics Curve

Pcv—T Curve

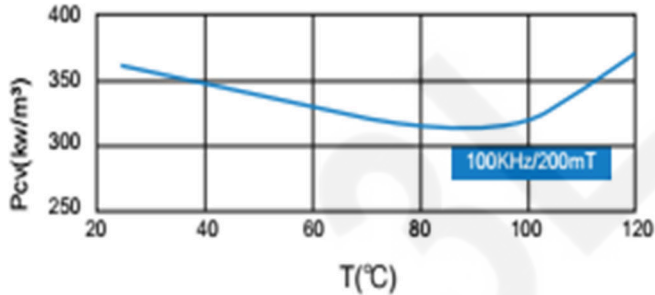

$\mu_i$ —T Curve

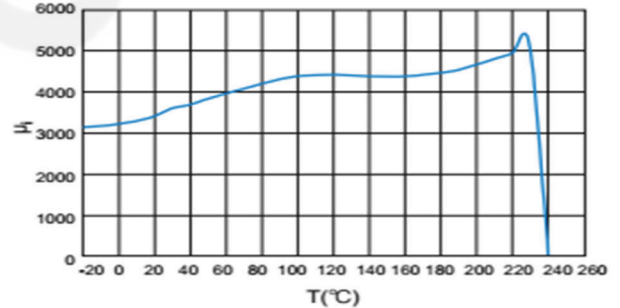

Bs—T Curve

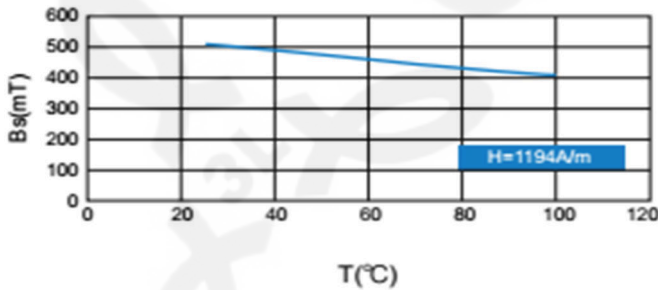

$\mu_i$ -f

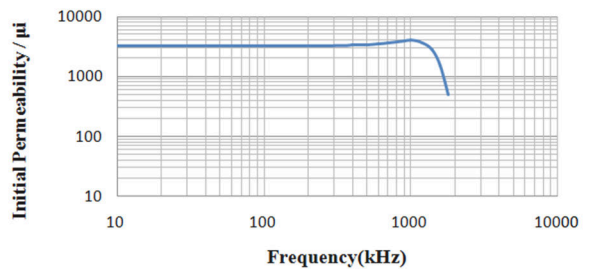

<b>3L P/N:</b>	WPT945404-120K-A13C	<b>Rev.</b>	XC	<b>Date:</b>	20220520
----------------	---------------------	-------------	----	--------------	----------

Customer: EG112	Customer P/N: 9-083-2205001
-----------------	-----------------------------

### 5.1 Metal Terminal Dimension (mm):

Applicable PCB Thickness: 1.60mm  
 Recommended PCB Hole Diameter:  $\phi 1.80 \pm 0.10 \text{mm}$

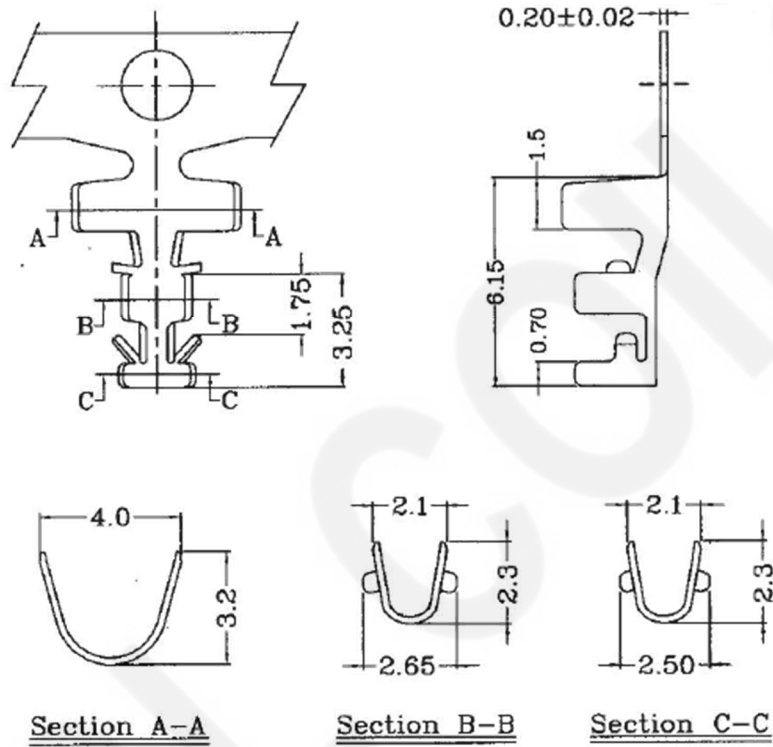

### 5.2 Metal Terminal Dimension (mm)-After processing:

T1	T2	T3	T4	T5
1.7+0.05	2.5+0.15	1.72MAX	2.0MAX	2.6+0.15

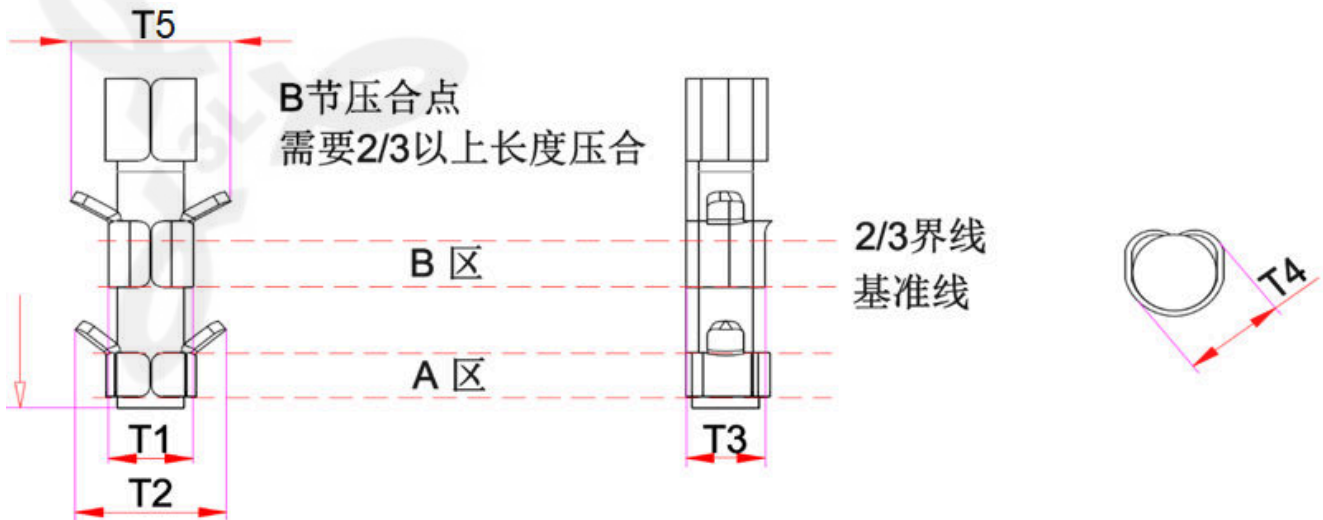

3L P/N: WPT945404-120K-A13C	Rev. XC	Date: 20220520
-----------------------------	---------	----------------



<b>Customer:</b> EG112	<b>Customer P/N:</b> 9-083-2205001
------------------------	------------------------------------

**6.1 INSIDE PACKAGING DRAW NO:**

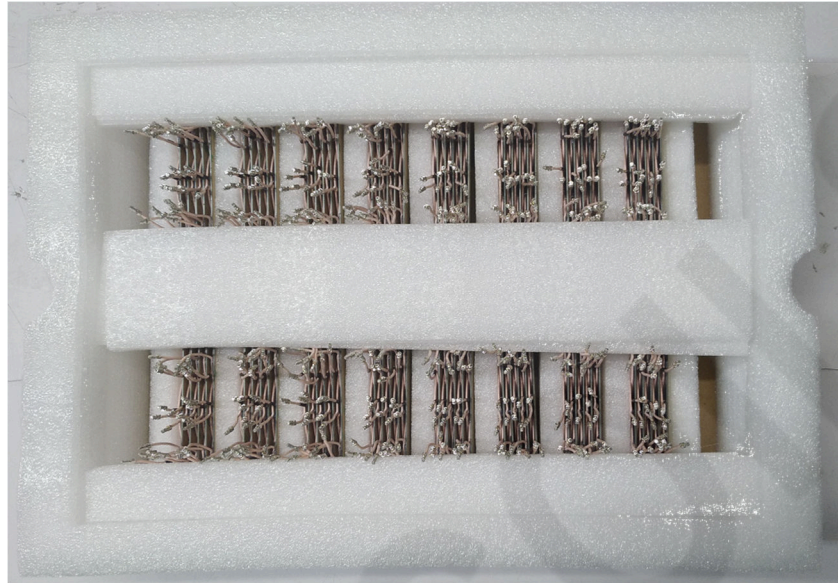

**Each board: 130 PCS**

**6.2 OUTSIDE PACKAGING DRAW NO:**

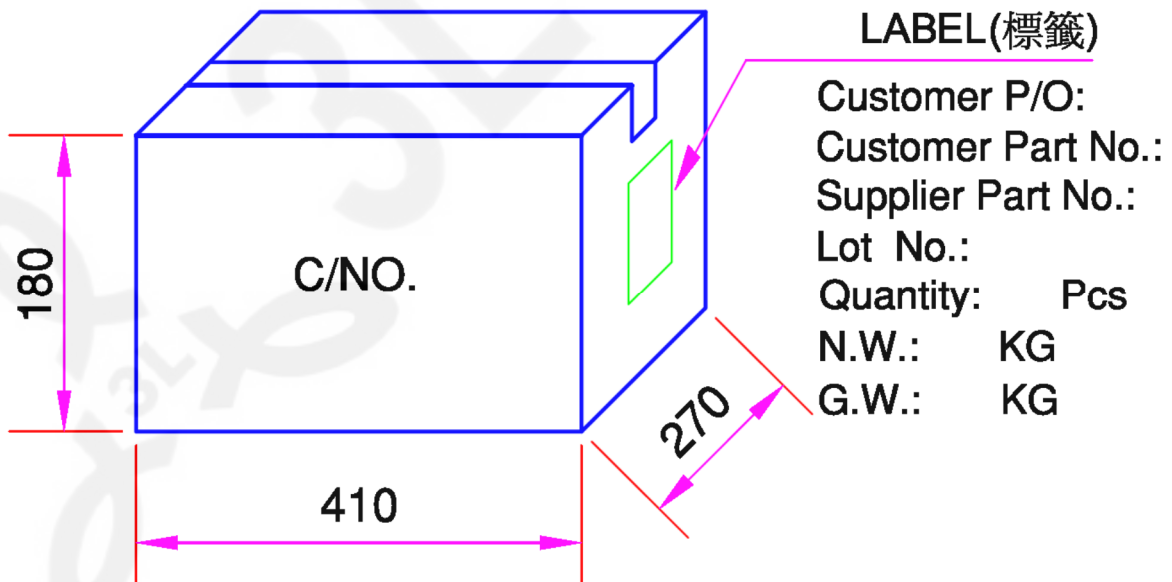

**Outer carton: 260 PCS**

<b>3L P/N:</b> WPT945404-120K-A13C	<b>Rev.:</b> XC	<b>Date:</b> 20220520
------------------------------------	-----------------	-----------------------

## Scope of 3L products:

1. 3L components are manufactured and promoted for applying in general electronics devices such as audio-video equipment, home electric appliance, office automation equipment, communication equipment, power module, LED lighting, measurement hardware, machine accessory, etc.
2. If 3L product will be applied in area like automotive product, medical equipment, military and aerospace except general electronic device, please keep 3L sales informed in advance. 3L shall not be held liable for any malfunction or breakdown caused by using product in the condition which is inconsistent with that recommended by 3L.
3. If there is problem occurring when using product or information on 3L's catalogue, which may affect industrial property or any other rights of 3L Group (or a third party), 3L Group shall not be held liable in such situation, nor grant any license to the offending party.
4. Some parts of this publication contain statements about the suitability of our products for certain areas of application. These statements are based on our knowledge of typical requirements that are often placed on our products in the areas of application concerned. We nevertheless expressly point out that such statements cannot be regarded as binding statements about the suitability of our products for a particular customer application.
5. Generally, 3L might not be familiar with either customer's specific application or actual requests as customer does. As a result, customer shall be responsible for checking and confirming whether 3L product with the performance described in the product specification is suitable for using in customer's particular application or not.
6. We also have to point out that in individual cases, any trouble or failure of electronic components happens during their long span cannot not be completely cleared even if someone operates according to instruction with existing technology.
7. Please pay attention to the storage conditions that temperature: below 35°C and humidity: 35-65% RH. If product is preserved for more than 1 year, the solderability of their terminals may be deteriorated.
8. 3L recommend reflow soldering for SMT product and wave soldering for DIP product while for specific DIP product, iron soldering might be preferred. Please confirm with 3L if other soldering method is applied to prevent issue such as short, open, fracture, deformation and etc., otherwise 3L will not take any responsibility for above issue.
9. The aforementioned items do not apply to individual agreements and the foregoing customer-specific products.

*Please read cautions and warnings, important notes at the end of this document.*

If you have any question, please contact 3L.

## General instruction for parts usage:

1. Please pay more attention to the installation position of the non-magnetic shield type coil when you design the printed circuit board to prevent malfunction caused by magnetic interference.

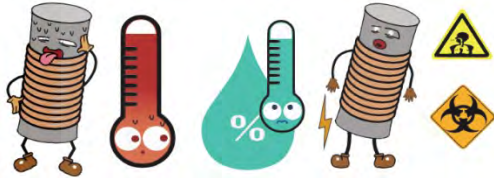
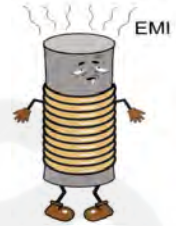

2. Product should not be exposed to environment with high temperature, high humidity, dust, corrosive gas and etc.

3. The soldering conditions should also be observed. Temperature mentioned refers to the temperature of wave soldering for PIN or terminals but not the temperature of product itself.

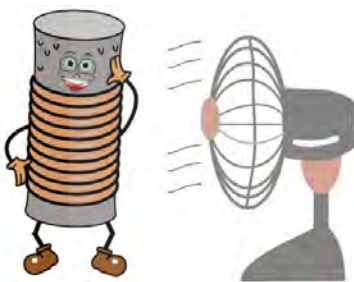
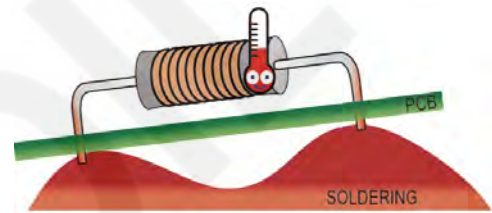

4. Please take the thermal design into consideration when choosing appropriate product, because the coil generates heat when electric current is applied.

5. Please don't use products in a place with dewing. Please be careful when products is applied in a sealed condition since dewing would happen due to temperature change.

6. Please always handle products carefully to prevent any damage caused by dropping down or inappropriate removing.



7. Don't touch electrodes directly with bare hands since oil secretions may do harm to solderability.

8. Don't bend the terminals with excessive stress in case of any wire fracture.



9. Please ensure that all terminals and case lugs are completely fixed onto PCB by soldering, and avoid placing coils near the edge of the PCB.

10. Don't rinse coils by yourself and please contact 3L if necessary.

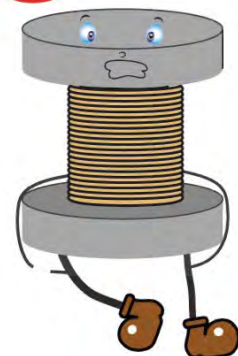

*Please read cautions and warnings, important notes at the end of this document.*

If you have any question, please contact 3L.

11. Since our SMD coils are designed for automatic mounting, please be careful when soldering manually. Please don't touch any exposed winding part and coil should not be used guiding by electrode in automatic mounting.

12. Our specification specifies the quality of the component as a single unit. Please ensure the component is thoroughly evaluated in your application circuit.

13. When using our high voltage inverter transformers, please place it 2mm away from other electric conductors.

14. The following points must be paid attention to if the components are potted or glued to stick in customer applications:

- Many potting materials shrink as they harden. Therefore, they exert a pressure on the plastic housing or core, which may have a deleterious effect on electrical performance. In extreme cases, it would damage the mechanical performance of core or plastic housing.
- It is necessary to check whether the potting material used would lead to undesirable performance or break down of insulating layer of enameled wire, plastic bobbin or glue.
- The potting material can affect the high-frequency behavior of components.
- Ferrites are sensitive to direct shock, which might hurt or even break the core.
- For non-Alloy or non-coated molded inductors, its surface might become rusted if it was left in the humid environment. However, its electrical performance would not be affected.
- Even for customer-specific products, conclusive validation of the component in the circuit can only be carried out by customer.

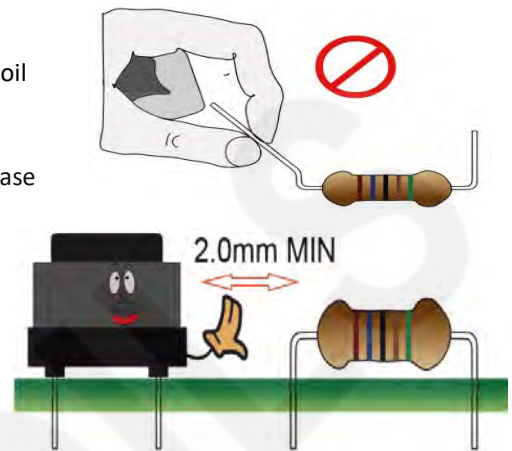

*Please read cautions and warnings, important notes at the end of this document.*

If you have any question, please contact 3L.

Note 1. The general testing condition is Temperature: 25 +/- 5°C (Room temperature) and humidity: 35-65% RH, which is applied to all products except specific product.

Note 2. For DIP type products, when the pin length is more than 5mm, the test position should be at 2-5mm away from the bottom of the product; For SMT type products, it is suggested to ensure better contact between the products and the tooling, shown as the right picture:

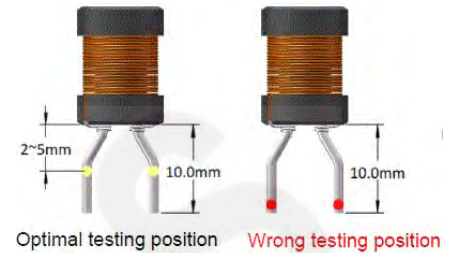

## 1. Inductance Test

There could be measurement deviations with different instruments due to different test principles / internal resistance. Open and Short compensation should be performed before testing. Select the measurement fixture or testing wire that goes with the original instrument.

## 2. Leakage Inductance Test

There could be measurement deviations with different instruments due to different test principles / internal resistance. Open and Short compensation should be performed before testing. Select the measurement fixture or testing wire that goes with the original instrument.

## 3. DCR Test

Shorten the testing wire as much as possible to ensure better contact between the products and the tooling; there would be deviations for the DCR if the testing tooling contact surface is worn out or if the testing method is not correct, especially for low DCR products.

## 4. Rated Current, Saturation Current, Temperature Rise Current

The saturation current is decided according to the initial inductance drop amount; the rated current is generally taken by the smaller value between the saturation current and temperature rise current.

## 5. Q Factor / SRF / Z Test

Shorten the pin length as much as possible to ensure better contact between the products and the tooling ;there can be deviation if the testing tooling contact surface is worn out or if the testing method is not correct.

## 6. Turns Ratio and Phase Test

There would be deviations for turn counts ratio when there is magnetic leakage or air gap in the core center, please pay attention to the differences during testing. If the air gap is too large, then use the planar cores for confirmation; be careful to choose the foot position when testing the polarity.

## 7. Hi-Pot Test

Choose AC or DC accordingly during Hi-pot testing since they are different. If the humidity is too high or there is pollution on the surface, the Hi-pot test might fail. Please avoid testing in high humidity condition and keep the tooling and products clean. The Hi-pot test is destructive test and repeat testing should be avoided.

## 8. IWT Test

Carefully choose the voltage and standard sample for the testing, IWT test is destructive testing and repeat testing should be avoided.

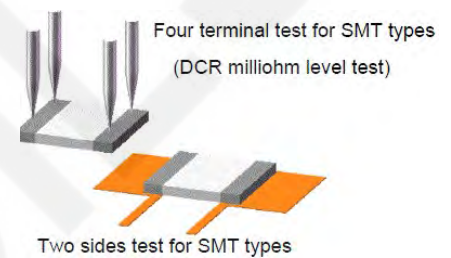

*Please read cautions and warnings, important notes at the end of this document.*

If you have any question, please contact 3L.