

**BougeRV**

# User Manual

Pure Sine Wave Inverter

Make The Journey



**FCC STATEMENT :** This device complies with Part 15 of the FCC Rules. Operation is subject to the following two conditions:  
 (1) This device may not cause harmful interference, and  
 (2) This device must accept any interference received, including interference that may cause undesired operation.

**Warning:** Changes or modifications not expressly approved by the party responsible for compliance could void the user's authority to operate the equipment.

NOTE: This equipment has been tested and found to comply with the limits for a Class B digital device, pursuant to Part 15 of the FCC Rules. These limits are designed to provide reasonable protection against harmful interference in a residential installation.

This equipment generates uses and can radiate radio frequency energy and, if not installed and used in accordance with the instructions, may cause harmful interference to radio communications. However, there is no guarantee that interference will not occur in a particular installation. If this equipment does cause harmful interference to radio or television reception, which can be determined by turning the equipment off and on, the user is encouraged to try to correct the interference by one or more of the following measures:

- Reorient or relocate the receiving antenna.
- Increase the separation between the equipment and receiver.
- Connect the equipment into an outlet on a circuit different from that to which the receiver is connected.
- Consult the dealer or an experienced radio/TV technician for help.

**FCC Radiation Exposure Statement**

This equipment complies with FCC radiation exposure limits set forth for an uncontrolled environment. This equipment should be installed and operated with minimum distance 20cm between the radiator & your body

**Content**

**1. Safety Instructions -----1**  
 1-1. Inverter Safety Information -----1  
 1-2. Connection Security Information -----1  
 1-3. Installation Safety Instructions -----2  
 1-4. Additional Safety note -----2

**2. Technical After Services -----3**

**3. Appearance And Interface Description -----4**  
 3.1. BV121000 -----4  
 3.2. BV122000 -----5  
 3.3 BV123000 -----6

**4. Installation and Wiring -----7**  
 4.1 Installation Steps -----7  
 4.2 Wiring Sequence -----8  
 4.2.1 Grounding Wire -----8  
 4.2.2 Battery Positive and Negative Wires -----8  
 4.2.3 AC Equipment -----8

**5. App Usage Instructions -----9**  
 5.1 Download -----9  
 5.2 Precautions For Using APP -----9

**6. External Display -----10**  
 6.1 Setting Method -----10

**7. Base Specification -----11**

**8. Indicators And Alarms -----13**

**9. Overload Protection Description -----14**

**10. RS485 Connection Diagram -----15**

**11. Error Code -----16**

**12. Recommended Cable Sizing -----17**

**13. FAQ -----18**

# 1. Safety Instructions

Please follow the safety instructions for operation, the damage caused by not following the safety instructions shall be borne by the individual.

⚠ **Please save these instructions**

## 1-1. Inverter Safety Information

1. Forbidden for non-professionals to disassemble, repair or modify the inverter.
2. Do not place the inverter where children can touch it.
3. Keep the inverter far away from harsh environments such as damp, greasy, flammable, explosive, or a large amount of dust.
4. The AC output of the inverter is a high voltage, please do not touch the wiring.
5. Please read the product installation steps to ensure all connections are correct.
6. Do not touch it when it working and keep away from materials or materials affected by high temperature.
7. Please do not open the terminal protection cover when the inverter is working.
8. Be sure to disconnect the fuse or circuit breaker near the battery and AC output terminals, before installing and adjusting the wiring of the inverter.
9. After installation, check whether all cable connections are tight to avoid the danger of heat accumulation due to virtual connections.
10. The inverter is off-grid, and the input power supply of the load equipment needs to confirm as the only input device, and do not use in parallel with other input AC power to avoid damage.

## 1-2. Connection Security Information

### 1. The DC voltage must be matched;

Each inverter has a nominal voltage, and the selected battery voltage must be consistent with the nominal DC input voltage of the inverter. For example, a 12V inverter must select a 12V battery.

### 2. The output power of the inverter must be higher than the maximum power of the electrical appliance;

The maximum power of equipment with large starting energy requirements, such as motors and air conditioners, cannot be higher than the output power of the inverter, and an additional power margin is required.

### 3. The positive and negative poles must be wired correctly;

The diameter of the connecting wire must be thick enough, and the length of the connecting wire should be minimized.

### 4. The inverter shell should be properly grounded to avoid personal injury due to leakage.

## 1-3. Installation Safety Instructions

1. Before installation, please read this manual carefully and be familiar with the installation steps.
2. Be very careful when installing the battery. When installing a lead-acid liquid battery, you should wear protective glasses. Once you come into contact with the battery acid, please rinse it with clean water in time.
3. Avoid placing metal objects near the battery to prevent short circuits of the battery.
4. Acid gas may be generated when the battery is charged, make sure the surrounding environment is well-ventilated.
5. When installing the cabinet, be sure to leave enough space around the inverter for heat dissipation; do not place the inverter and the lead-acid liquid battery together.
6. False connection points and corroded wires can cause extreme heat to melt wire insulation, burn surrounding materials, and even cause fire, so make sure that the connectors are tightened, and the wires are fixed by cable ties to avoid loose connectors caused by shaking of the wires during mobile applications.
7. When installing outdoors, avoid direct sunlight and rainwater infiltration.
8. After the power switch is turned off, there is still high voltage inside the inverter, please do not open or touch the internal components, and related operations can only be performed after the capacitor is fully discharged.
9. Please do not install the inverter in harsh environments such as damp, greasy, flammable, explosive, or a large amount of dust.
10. It is forbidden to reverse the polarity of the battery input terminal of this product, otherwise, it is easy to damage the equipment or cause unpredictable dangers.
11. The AC output is a high voltage, please do not touch the wiring.
12. When the fan is working, do not touch it to avoid injury.
13. It is necessary to confirm that the inverter is the only input device for the input power of the load equipment, and it is forbidden to use it in parallel with other input AC power sources to avoid damage.

## 1-4. Additional Safety Note

In order to protect the personal and property safety of users while using this product, the relevant information is provided in the manual and highlighted with the following symbols. If you encounter the following symbols in the manual, please read the relevant text carefully.

**WARNING:** Indicates a hazard of electric shock which, if not avoided, will result in equipment damage or personal electric shock/injury.

**ATTENTION:** Indicates a potential hazard that, if not avoided, could result in equipment damage.

**NOTE:** Indicates an important prompt during operation, failure to execute may cause an equipment failure alarm.

## 2. Technical After Services

BougeRV provides a **1-on-1** solar solution and an **18-month warranty** service.

If you have any questions during use, please feel free to contact us:

✉ (US/CA) [service@bougevr.com](mailto:service@bougevr.com)

✉ (BougeRV Website) [support@bougevr.com](mailto:support@bougevr.com)

☎ **1-408-656-8402** 9:00AM-6:00PM(CST) Mon-Fri

🌐 [www.bougevr.com](http://www.bougevr.com)

📞 **1-669-232-7427**

If you could provide the following relevant information to our email before contacting us; we can provide you with technical support solutions faster.

- (1) Voltage of battery.
- (2) Power of electrical appliance etc.

The company does not assume any responsibility for damages caused by the following circumstances.

1. Damage caused by improper use or use in an inappropriate place.
2. The current, voltage, and power of the load exceed the limit value of the inverter.
3. Damage caused by the working environment temperature exceeding the limited working temperature range.
4. Unauthorized disassembly and maintenance of the inverter due to arcing, fire, explosion and other accidents caused by failure to follow the inverter logo or manual instructions.
5. Force majeure.

## 3. Appearance And Interface Description

### 3.1. BV121000

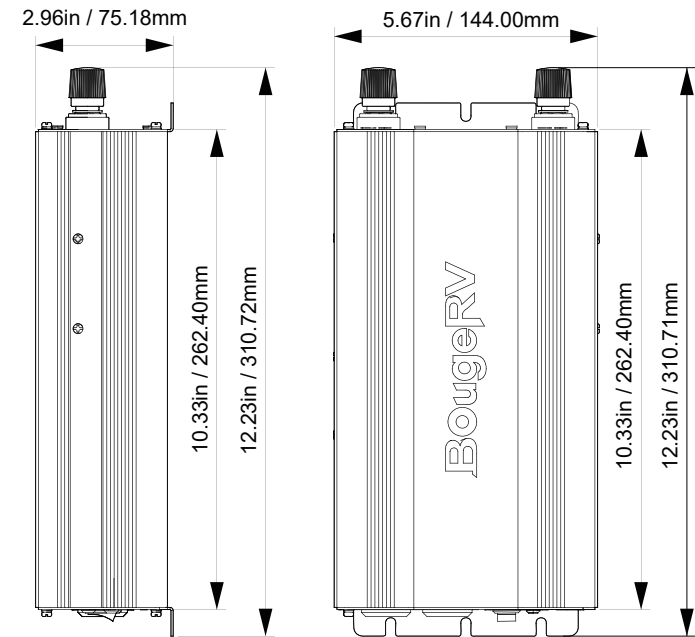

### Interface Description:

- ① Positive electrode of battery input
- ② Negative electrode of Battery input
- ③ Cooling fan
- ④ AC output terminal 1 (15A)
- ⑤ AC output terminal 2 (15A)
- ⑥ ON/OFF switch
- ⑦ Fault indicator
- ⑧ Running indicator
- ⑨ RS485 communication interface
- ⑩ USB interface
- ⑪ Input grounding terminal

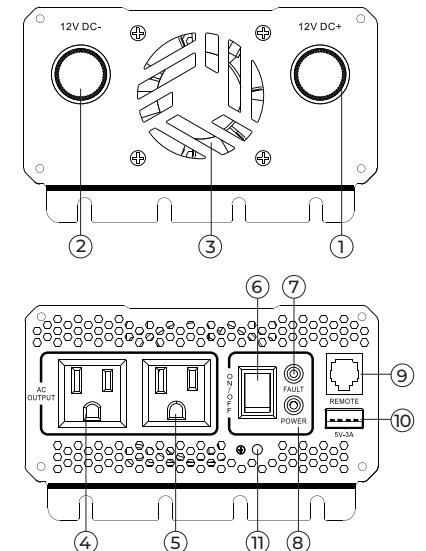

### 3.2. BV122000

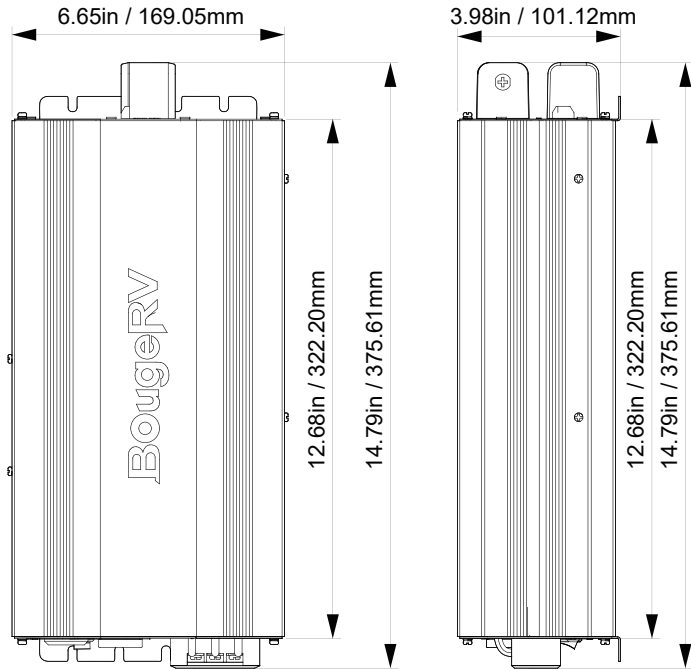

#### Interface Description:

- ① Positive electrode of battery input
- ② Negative electrode of Battery input
- ③ Cooling fan
- ④ AC output terminal 1 (15A)
- ⑤ AC output terminal 2 (20A)
- ⑥ ON/OFF switch
- ⑦ Fault indicator
- ⑧ Running indicator
- ⑨ RS485 communication interface
- ⑩ USB interface
- ⑪ Input grounding terminal
- ⑫ AC high power link port

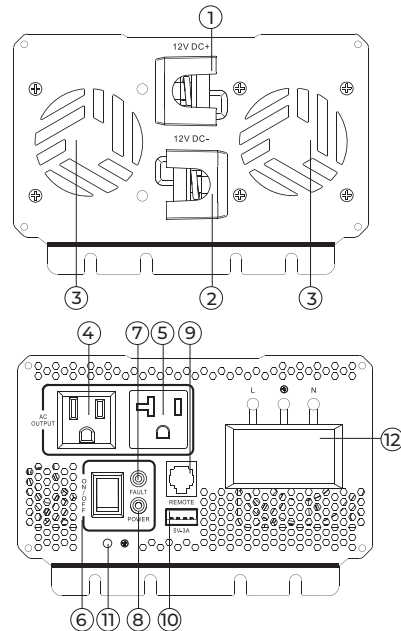

### 3.1. BV123000

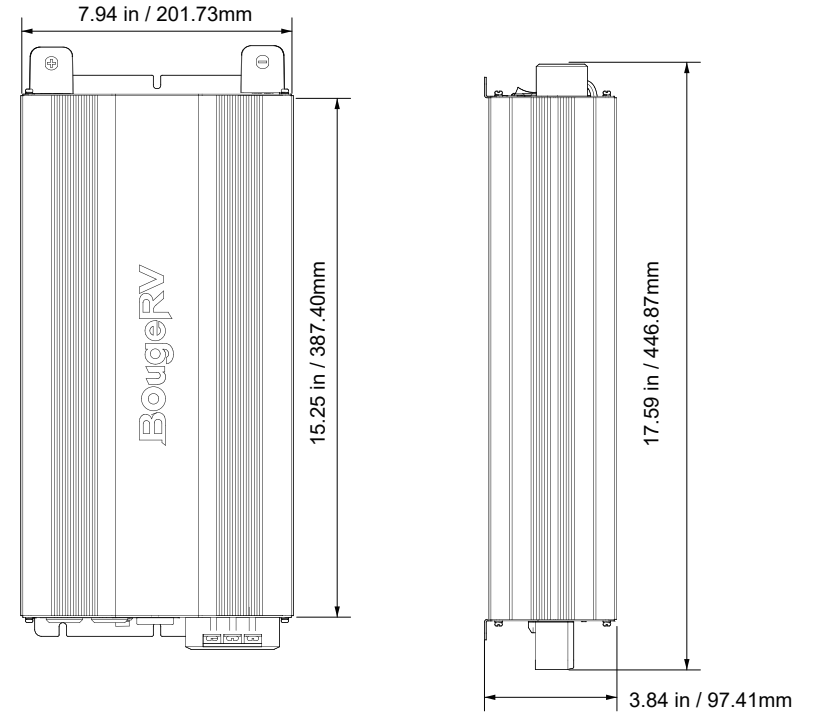

#### Interface Description:

- ① Positive electrode of battery input
- ② Negative electrode of Battery input
- ③ Cooling fan
- ④ AC output terminal 1 (15A)
- ⑤ AC output terminal 2 (20A)
- ⑥ ON/OFF switch
- ⑦ Fault indicator
- ⑧ Running indicator
- ⑨ RS485 communication interface
- ⑩ USB interface
- ⑪ Input grounding terminal
- ⑫ AC high power link port

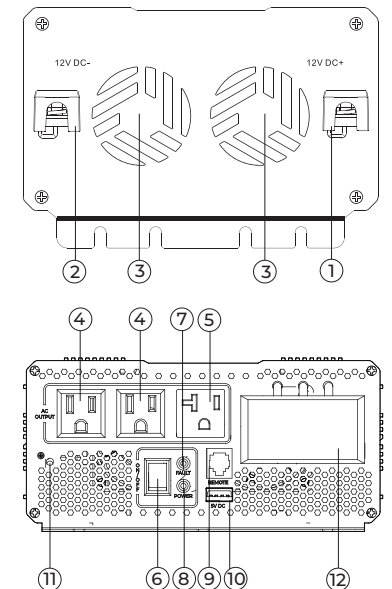

## 4. Installation and Wiring

### 4.1 Installation Steps:

**Step 1:** Read the user manual carefully.

**Step 2:** Determine the installation position and heat dissipation space.

Determine the installation position (wall-mounted or horizontal installation mode can be used).

When installing the inverter, ensure that sufficient space is available and the inverter is removed

At least 200mm (7.9in) space should be left between the tuyere and the intake for air circulation.

If installed in a closed container, ensure that heat dissipation can be dissipated through the container; otherwise, reduce the amount of heat used.

**Step 3:** Connect cables

1. The AC device shall be determined according to the continuous output power of the inverter, but the impact power of the AC device. Do not exceed the instantaneous impact power of the inverter. Otherwise, the inverter may be damaged.
2. Before wiring, set the inverter switch to OFF state.
3. During the wiring process, do not close the circuit breaker or safety, and confirm the lead connection of the electrodes of each component.
4. The battery end needs to be installed with insurance, which is selected according to the inverter input rated current of 2-2.5 times.
5. Ensure that the safe position is not more than 150mm away from the battery.
6. The input has no reverse connection protection. Before connecting the battery cable, ensure that the positive and negative terminals are correctly connected.

### 4.2 Wiring Sequence

#### 4.2.1 Grounding Wire

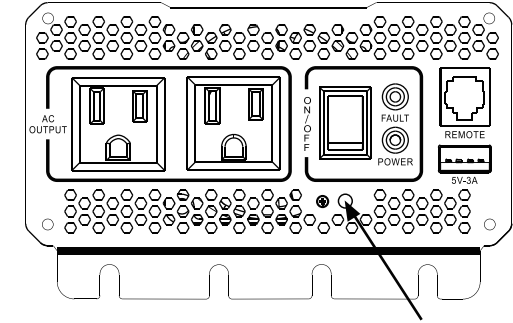

#### 4.2.2 Battery Positive and Negative Wires

Input has no reverse connection protection. Before connecting the battery cable, ensure that the positive and negative terminals are correctly connected; otherwise, the inverter may be damaged!

#### 4.2.3 AC Equipment

L: Live wire; N: Neutral wire; +: Ground wire

Please connect the ground wire first, then the fire wire L and zero wire N.

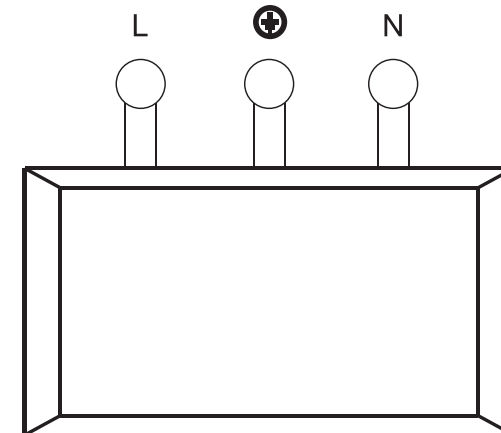

## 5. App Usage Instructions

Built-in Bluetooth communication function can monitor the operation data, fault status and adjust the operation parameters of the controller in real time through mobile APP.

### 5.1 Download

Scan the QR code to download the application;



IOS & Android

Search for "BougeRV" in the APP Store (for IOS devices) or Google Play (for Android devices).

### 5.2 Precautions For Using APP

1. Make sure the inverter is turned on before connecting to Bluetooth.
2. The Bluetooth function of the mobile phone is available and turned on.
3. The GPS function is available and turned on in your phone.
4. Android firmware 8.0 and above, or IOS firmware 13.0 and above.
5. If you cannot connect to the app, you need to set it up on the external display: press and hold the AC button for 5 seconds, reset bluetooth and then reconnect to the app;

## 6. External Display

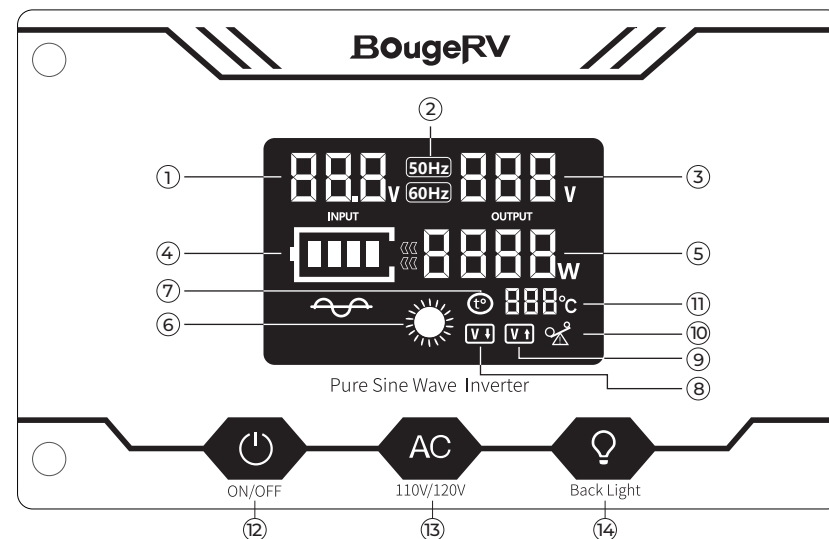

- |                               |                             |                  |
|-------------------------------|-----------------------------|------------------|
| ① Input voltage               | ② Output frequency          | ③ Output voltage |
| ④ Battery power               | ⑤ Output power              | ⑥ Working status |
| ⑦ Over temperature protection | ⑧ Over discharge protection |                  |
| ⑨ Overvoltage protection      | ⑩ Overload protection       |                  |
| ⑪ Inverter temperature        | ⑫ Inverter switch           |                  |
| ⑬ AC voltage switch           | ⑭ Backlight switch          |                  |

### 6.1 Setting Method

1. Inverter switch: Single press **[ON/OFF]** to switch ON/OFF.
2. AC voltage switch:
  - ① Single press **[AC]** to switch the AC output voltage. (110V/120V, default 120V)
  - ② Press and hold **[AC]** for more than 5s to reset bluetooth and then reconnect to the app.
3. Backlight switch: Single press **[Back Light]** to control the display backlight switch.

## 7. Base Specification

Model	BV121000	BV122000
Rated output power	1000W	2000W
Peak power	2000W (1s)	4000W (1s)
Output voltage	110VAC/120VAC(default)	
Output frequency	50/60 Hz(default)	
Rated input voltage	12VDC	
The input voltage ranges	10V-15.5VDC	
Output waveform	Pure sine wave	
Maximun output efficiency	>90%	
Full Load Efficiency	>86%	
Battery low voltage alarm	10.5VDC (±0.3V)	
Over-discharge voltage	10VDC (±0.3V)	
Overvoltage	15.5VDC (±0.3V)	
Operating ambient temperature range	-40°F~-185°F (-40°C~85°C)	
Storage temperature range	-40°F~176°F (-40°C~80°C)	
Noise	≤60dB	
Communication Port	RS485+Inbuilt Bluetooth	
Fan start-up temp	≥113°F (45°C) /≥50% load	
USB port	18W*1 (5V-3A,9V-2A,12V-1.5A)	
Protection function	Input over-voltage/ over-discharge protection, output overload/short-circuit protection, and inverter overtemperature protection	
Output harmonic component (THD)	<3%	<4%
Over-temperature protection recovery	≤167°F (75°C)	≤158°F (70°C)
No-load Loss	<0.5A	<0.7A
Over temperature protect	≥203°F (95°C)	≥176°F (80°C)
Product size	12.23*5.67*2.96 in	14.79*6.65*3.98 in
Weight	5.07 lb	8.6 lb

Model	BV123000
Rated output power	3000W
Peak power	6000W (1s)
Output voltage	110VAC/120VAC(default)
Output frequency	50/60 Hz(default)
Rated input voltage	12VDC
The input voltage ranges	10V-15.5VDC
Output waveform	Pure sine wave
Maximun output efficiency	>90%
Full Load Efficiency	>86%
Battery low voltage alarm	10.5VDC (±0.3V)
Over-discharge voltage	10VDC (±0.3V)
Overvoltage	15.5VDC (±0.3V)
Operating ambient temperature range	-40°F~-185°F (-40°C~85°C)
Storage temperature range	-40°F~176°F (-40°C~80°C)
Noise	≤60dB
Communication Port	RS485+Inbuilt Bluetooth
Fan start-up temp	≥113°F (45°C) /≥50% load
USB port	18W*1 (5V-3A,9V-2A,12V-1.5A)
Protection function	Input over-voltage/ over-discharge protection, output overload/short-circuit protection, and inverter overtemperature protection
Output harmonic component (THD)	<5%
Over-temperature protection recovery	≥176°F (80°C)
No-load Loss	<0.9A
Over temperature protect	≥203°F (95°C)
Product size	17.59*7.94*3.84 in
Weight	14.3 lb



## 8. Indicators And Alarms

Working status	Running indicator Run-blue	Fault indicator Fault-red	Buzzer
Power on	Steady On	Off	No sound
Shut down	Off	Off	No sound
Under-voltage alarm	Steady On	Off	Buzzer sounds 4 times
Under-voltage protection	Steady On	Steady On	Buzzer sounds 4 times
Undervoltage recovery	Steady On	Off	Buzzer sounds 1 times
Overvoltage protection	Steady On	Steady On	Buzzer sounds 3 times
Overvoltage recovery	Steady On	Off	No sound
Short circuit protection	Steady On	Steady On	Buzzer sounds 1 times
Overload protection	Steady On	Steady On	Buzzer sounds 2 times
Over temperature protect	Steady On	Steady On	Buzzer sounds 4 times

## 9. Overload Protection Description

### 3.1. BV121000

Load power	Possible duration
$120\% \leq P_o \leq 125\%$	20s
$125\% \leq P_o \leq 150\%$	<10s
$P_o > 150\%$	<5s, Stop output if the AC voltage is less than 90V.

### 3.2. BV122000

Load power	Possible duration
$110\% \leq P_o \leq 115\%$	20s
$115\% \leq P_o \leq 130\%$	<10s
$P_o > 130\%$	<5s, Stop output if the AC voltage is less than 90V.

### 3.2. BV123000

Load power	Possible duration
$105\% \leq P_o \leq 108\%$	20s
$108\% \leq P_o \leq 143\%$	<10s
$P_o > 143\%$	<5s, Stop output if the AC voltage is less than 90V.

## 10. RS485 Connection Diagram

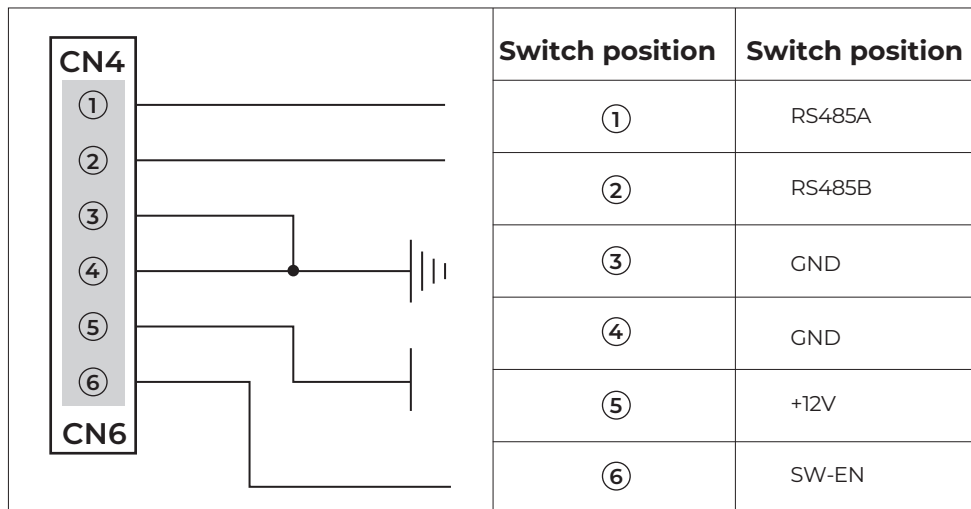

## 11. Error Code

Error code	Cause of failure	Solution
F01	Parameter configuration fault	Restart the inverter
F02	Circuit sampling fault	Check and repair the current sampling circuit and restart the inverter.
F03	DC busbar low-voltage	① Check whether the power tube of the latter stage is short-circuited. ② Check the front-stage boost circuit or DC line components.
F04	There are other power supplies in output circuit	Check if there is any other power source connected to the output wiring.
F05	Inverter output short circuit protection	Check the output wiring and the load.
F06	Inverter over-current protection	Reduce the load.
F07	Inverter overload protection	Reduce the load.
F08	Inverter overheating protection	① Check the fan or air duct, lower the ambient temperature. ② reduce/turn off the load output, and wait for the inverter to cool down.
F10	Battery over-voltage protection	Check whether the input power supply or charger is functioning properly.
F11	DC busbar over-voltage	① Check the input power supply. ② Internal damage to the machine.
F12	Battery low voltage warning	Charge the battery or replace it.
F13	Data read error	Restart the inverter.

## 12.Recommended Cable Sizing

PVC copper cable size(AWG/mm <sup>2</sup> )	Ampcaity(A)tested at 194°F
8 (8.37)	55
6 (13.3)	75
4 (21.2)	95
3 (26.7)	115
2 (33.6)	130
1 (42.4)	145
1/0 (53.5)	170
2/0 (67.4)	195
3/0 (85.0)	225
4/0 (107)	260

## 13. FAQ

**Q1: When I have some problems in the process of using the inverter, what information can I provide to BougeRV to provide me with technical support faster and better?**

**A1:** Send the following information to the email ,  
 ①The connection method of the inverter and battery.  
 ②The voltage and battery type of the battery.  
 ③The display data/app data of the inverter.  
 ④Connection from battery to inverter and inverter to the loads.

If the above information can be provided with pictures or videos, BougeRV can provide you with technical support faster.

**Q2: Can I use the inverter with a 24 V system?**

**A2:** No. This model can only work with a 12V battery system.

**Q3: Can I use this inverter to charge my batteries?**

**A3:** No. The BougeRV 12VDC to 120VAC inverter can only convert DC power to AC power. Please check the BougeRV Pure Sine Wave Inverter Charger.

**Q4: How to check the power consumption of this inverter?**

**A4:** This inverter has a built-in Bluetooth module, and parameters can be set and viewed on the mobile APP.

**Q5: Why does the inverter suddenly disconnect during work?**

**A5:** 1. The battery voltage is low, start the over-discharge protection, and it can work normally after recharging the battery;

2. Battery overcurrent. Most batteries are discharged at 1C(1C discharge refers to: The max discharge current of a 100AH battery is 100A, and the max discharge current of a 50AH battery is 50A.), and a 1500W electrical appliance connected to a 2000W inverter connected to 12V 100AH will cause overcurrent.

Because after connecting a 1500W electrical appliance, the inverter needs to get  $1500W/12.8V=117.19A > 100A$  from the battery. In this case, the battery will start protection and disconnect from other devices.

Connecting batteries in parallel to increase the current can solve this problem.

3. The power of the electrical appliance is greater than the rated output power of the inverter. For example, using the 2000W inverter to carry a 2500W high-power electrical appliance cannot work. At the same time, the inverter can withstand a maximum instantaneous impact power of 4000W. This means that even if the rated power of the electrical appliance is less than 2000W, excessive instantaneous power will cause abnormal operation and even damage the inverter.

# BougeRV

Make the journey



(US/CA) [service@bougeRV.com](mailto:service@bougeRV.com)



(BougeRV Website) [support@bougeRV.com](mailto:support@bougeRV.com)



**1-408-656-8402** 9:00AM-6:00PM(CST) Mon-Fri



[www.bougeRV.com](http://www.bougeRV.com)



**1-669-232-7427**

Whatsapp