

**IZIP** <sup>TM/MC</sup>

184-1700-0

*izip* *Glide E.Scooter*  
USER MANUAL

## TABLE OF CONTENTS

Table of Contents	1
Package Contents	2
Product Overview	3
Control Panel	4
Assembly	5
Quick Start Guide	6
Charging	7
Learning to Ride	8–9
Riding/Safety Instructions	10–13
Safety Notice & Warning	14
Folding &Transport	15
Daily Care & Maintenance	16–18
Specifications	19
Warranty Info	20
Frequently Asked Questions	21
Contact Us	22



## Package Contents

Please read entire owner's manual prior to use.

**STOP** Contact us if you experience issues relating to riding maintenance and safety or errors/faults.

Customer Service Centre: 86 579 88030579



### Accessories

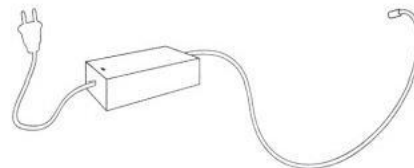

Charging Adapter

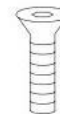

HexKey

Screwsx4

## Product Overview

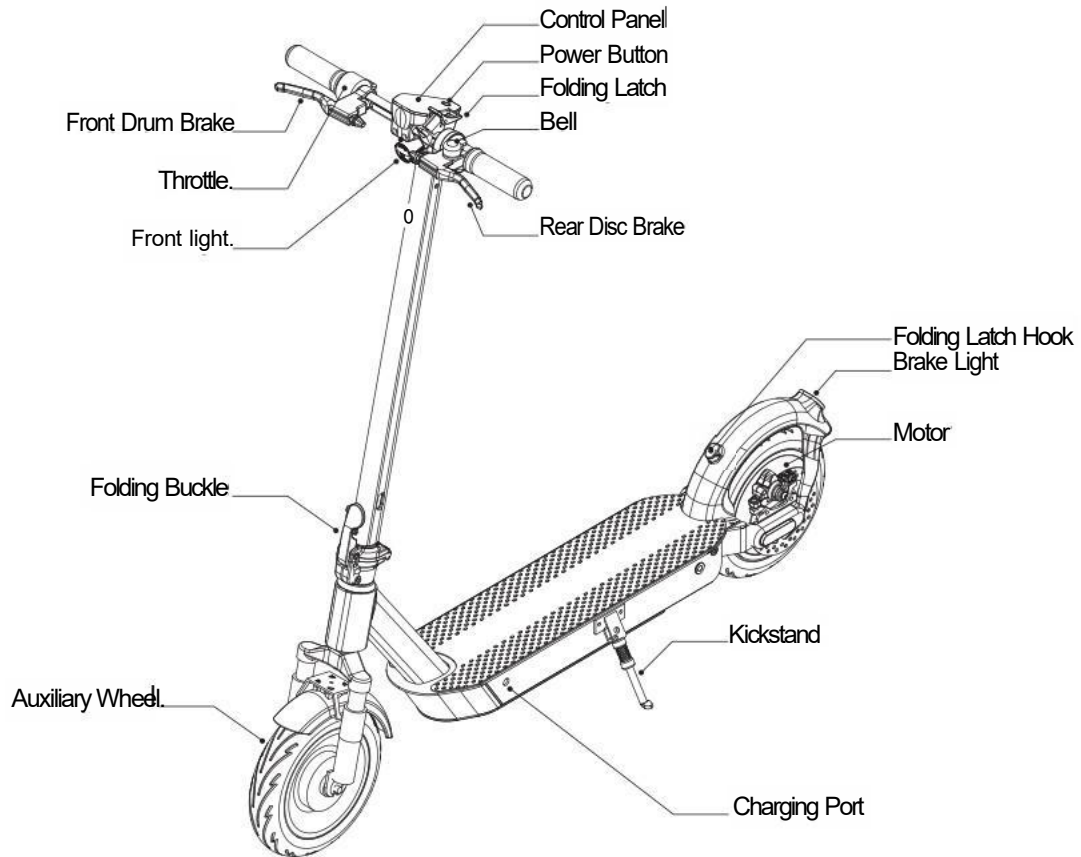

# Control Panel

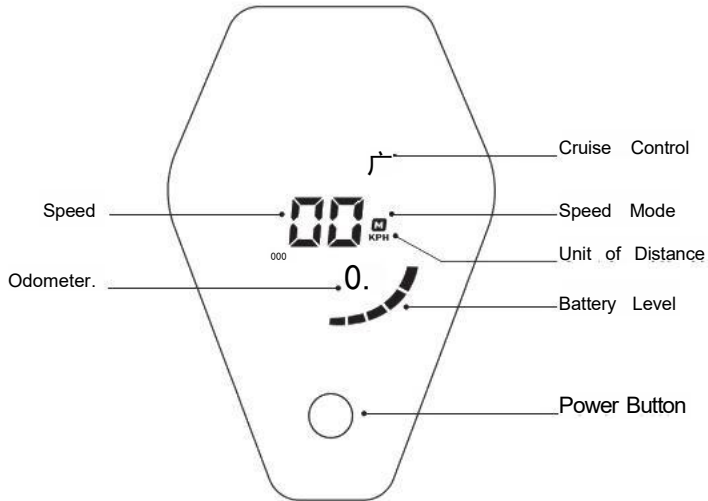

## **SPEED DISPLAY**

There are 3 speed modes for the iZip Glide E-Scooter:

Eco Mode: 15km/h

Intermediate Mode: 25km/h

Sport Mode: 32km/h

The color on the LED display will advise which mode you are travelling in:

Green (Eco) = 15km/h

White = 25 km/h

Red (Sport) = 32km/h

## **BATTERY LEVEL INDICATOR**

There are five bars that indicate how much power is left in the battery and when you need to re-charge your E-Scooter. When all 5 bars are visible, the battery power is between 80%-100%. When 4 are bars are visible, the battery power remaining is between 60%-80%. When 3 bars are visible the battery power remaining is between 40%-60%. When 2 bars are visible the battery power remaining is 20%-40%. When 1 bar is visible the battery power remaining is 0%-20% and you need to re-charge the E-scooter.

## **POWER SWITCH**

Long press the power button to turn ON the iZip Glide E-Scooter.

Long press the power button for 2 seconds to turn it OFF.

Once the iZip Glide E-Scooter is powered ON, short press the power button to turn ON/OFF the lights.

Press the power button 2 times in a row to switch between speed modes.

## **CRUISE CONTROL**

Press the power button 6 times in a row to turn ON or OFF the cruise control function. When turned ON, 2 beeps will sound and when turned OFF, 1 beep will sound. This is how you can confirm whether cruise is ON or OFF before starting to ride. While riding with cruise control ON, cruise control will activate when traveling at the same speed for 5 seconds. The cruise control will be visible on the LED display and 2 beeps will sound when cruise is activated. Pressing either brake lever or changing the speed mode will automatically turn OFF cruise control. To re-activate cruise control, simply hold the throttle to accelerate at a constant speed again for 5 seconds. NOTE: It is suggested to turn ON or OFF cruise control before you begin riding. If you want to switch while riding, you should come to a full stop to do so.

## Assembly

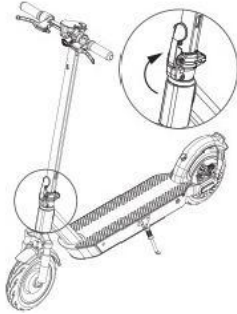

1. Straighten the steering column and flip up the locking mechanism until it's securely in place. Then unfold the kickstand to support the scooter as you continue assembling the iZIP Glide E-Scooter.

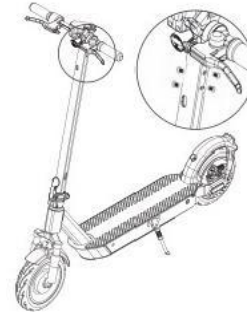

2. Install the handlebars onto the steering column.

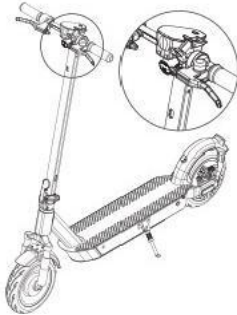

3. Use the hex key and screws that is included in the box to secure and lock the crossbar/handlebars onto the steering column.



4. Your iZip Glide E-Scooter is now ready and you can press the power button to turn on the LED screen and activate the E-Scooter.

## Quick Start

- 1.To turn ON/OFF the power: press and hold the power button for 2-3 seconds.
- 2.Switch between the different speed modes by double clicking the power button:
  - ECO Mode: A"M" icon will appear on the LED screen in green.
  - Intermediate Mode:A"M" icon will appear on the LED screen in white.
  - Sports Mode: A"M" icon will appear on the LED screen in red.
- 3.To turn ON/OFF the headlights: Press the power button.
- 4.Switching between Km/h and Mph: Triple click the power button.
- 5.Motor Startup: Non-Zero Star(Push to Start): Stand on the scooter deck with one foot and propel yourself forward with the other foot to get the scooter moving.

Once 5 km/h(3.1 mph)is achieved you can then push on the throttle paddle to accelerate via the power of the motor.
6. Cruise Control: Press the power button 6 times to turn ON/OFF the cruise control function.

### Deactivating Cruise Control Mode:

- Gently apply the left-hand brake lever(disc brake, rear wheel) or right-hand brake lever(drum brake, front wheel).  
OR
  - Press the throttle while cruise control is activated.
- 7.△ **WARNING:** For safety, the scooter is equipped with a dual mechanical braking system: front drum brake and rear disc brake. The right brake handle controls the front drum brake, and left brake handle controls the rear disc brake. We highly recommend riders to use the right brake handle preferentially when there is a need to stop the scooter. Because the left handle disc brake directly controls the motor there is a danger of falling over if it is used suddenly especially when riding fast.



## Charging

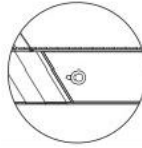

1. Remove the rubber plug to expose the charging connector

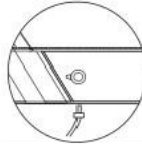

2. Insert the charging plug into the charging connector.

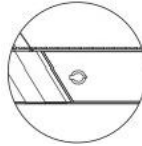

3. Be sure to re-install the rubber plug after charging.

**WARNING:** Do not turn on the scooter when it is charging. Your scooter will be fully charged when the LED light on the charger changes from red (charging) to green (fully charged). Do not charge your scooter for long periods of time. Do not connect the charger if the charging port is wet. Make sure to cover the charging port at all times after charging is complete.

## How to Ride

### **⚠️ WARNING**

Always wear a helmet as well as knee & elbow pads to help mitigate injuries in case of a fall. Note: Do not rest your feet on the rear mudguard.

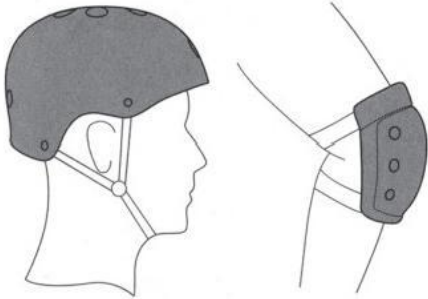

Always wear a helmet and proper safety gear; even after you have learned how to ride the scooter and have become comfortable with the balance and controls.

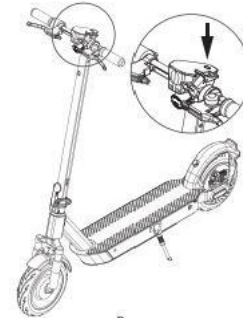

1. Turn on the power and check the power.



2. Stand on the footrest with one foot and push off with the other foot to start the scooter coasting.

## How to Ride

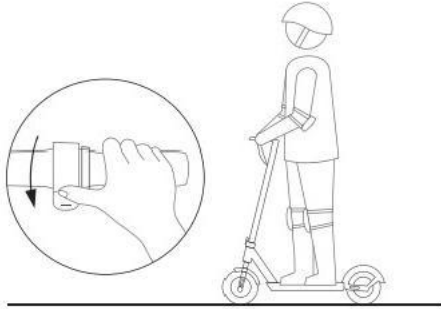

3. When the scooter starts coasting put both feet on the scooter deck and press the throttle. In order for the motor to activate the scooter needs to be moving at a speed of at least 5km/hour(3miles/hour).

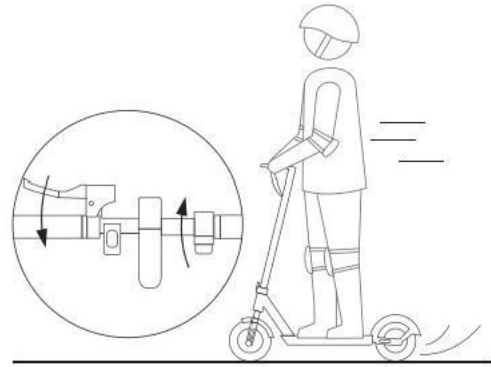

4. Releasing the throttle will gradually reduce the speed.

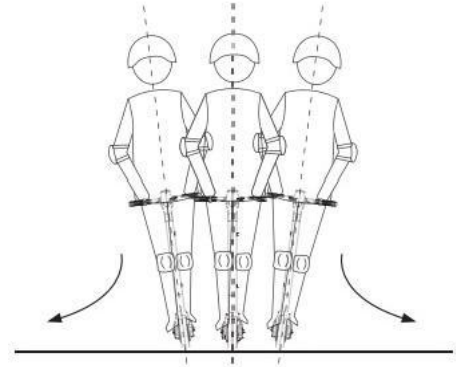

5. Tilt your body to the steering direction as you turn and slowly turn the handlebar.

## Riding/Safety Instructions



⚠ Do not ride in the rain..

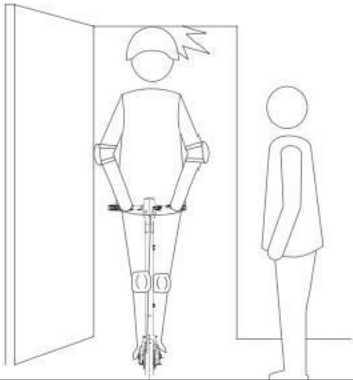

⚠ Look out for doors, elevators and other overhead obstacles.



⚠ Please keep a medium or low speed <math>< 8 \text{ km/h}</math> (4.9 mph) when you ride over speed bumps, elevator door sills, bumpy roads or other uneven surfaces. Slightly bend your knees to better adjust to different surfaces.



⚠ Do not accelerate when going downhill.

## Riding Notice

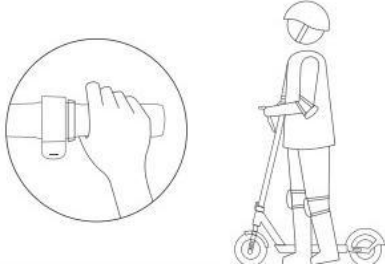

△ Do not press the throttle when walking with the scooter.

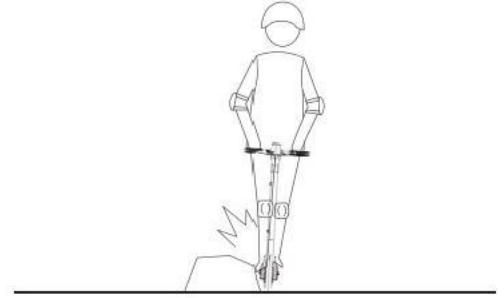

△ Always steer clear of obstacles.

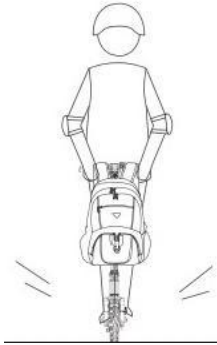



⚠ Do not hang bags or heavy objects such as backpacks on the handlebar.

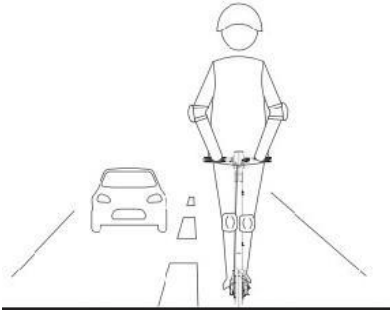

△ Keep both feet on the deck at all times.

## Dangerous Actions(Do not attempt)



 **WARNING:** Please ensure to review and follow all local by-laws applicable to the location where you intend to use the E-Scooter.



 **Do not ride in puddles.**

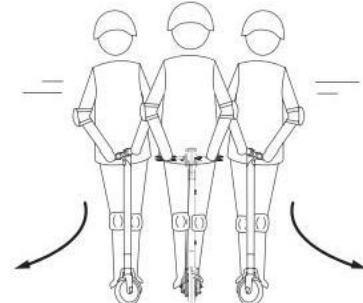

 **Do not turn the handlebar violently during high speed riding.**

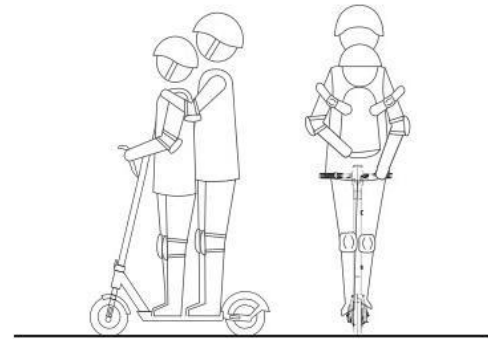

 **Do not ride with passengers or try to carry anyone else including children.**

## Dangerous Actions(Do not attempt)

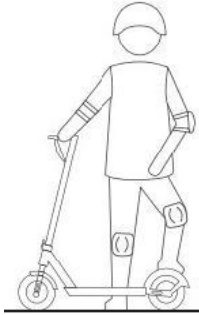

⚠ Do not step on the back of the fender.

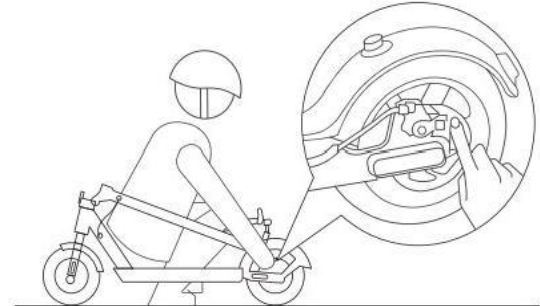

Do not touch the disc brakes as they may be hot.



⚠ Never let go of the handlebars while riding.

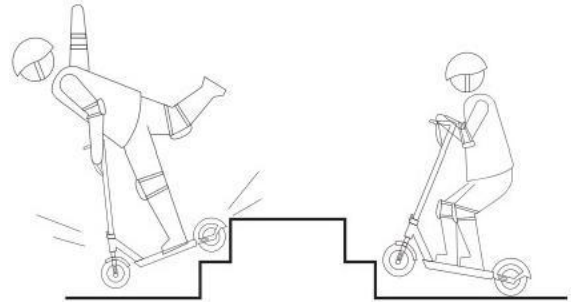

⚠ Do not try riding up or down stairs or jumping over obstacles.

## Safety Notice

The iZIP Glide electric scooter is a leisure device. But once in a public area, e-scooters are viewed as vehicles and are subject to the same risks faced by vehicles. For your safety, please follow instructions in the user manual and all traffic laws and regulations set forth by government and regulatory agencies.

·At the same time you should understand that risks cannot be entirely avoided as others may violate traffic regulations and drive incautiously. You are exposed to road accidents while riding a e-scooter the same way you are exposed while walking or biking. The faster the scooter is going the longer it takes to stop. On a smooth surface, the scooter may slip, lose balance, and even result in a fall.

Thus it is crucial that you use caution and keep proper speed and distance, especially when you are riding in an unfamiliar place.

·Always respect pedestrians' Right of Way. Try not to startle others while passing or riding nearby-especially children. When you ride from behind pedestrians and other lane users, ring your bell to make them aware of your presence, and slow down the scooter to pass. When you ride near pedestrians, slow down to a very low speed. When coming upon busy areas with pedestrians, you should stop, get off and walk the scooter.

**△ WARNING:** Please ensure to review and follow all local by-laws applicable to the location where you intend to use your scooter.

·Closely follow the safety instructions in the user manual. iZIP shall not be liable for any financial losses, physical injuries, accidents, legal disputes and other interest conflicts resulted from actions that violate user instructions.

· Check the scooter before every use. If you notice any loose parts, low battery alerts, excessive wear, strange sounds, malfunctions, and/or any other abnormal conditions, stop riding.



## Folding and Carrying the izip Glide E-Scooter

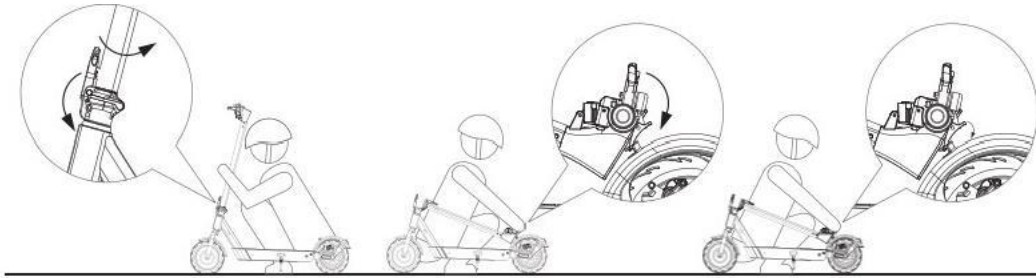

Make sure that the electric scooter is turned OFF. Release the locking latch at the front that you secure in place to assemble the izip Glide E-Scooter. Move the handlebars/steering shaft down towards the back wheel and latch the bell hook to the hook on the rear fender. Once in place you can pick the iZip Glide with either 1 or 2 hands from the steering column and carry it to your desired location.

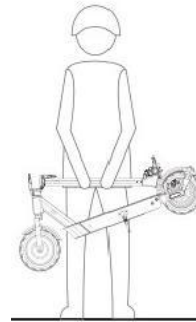
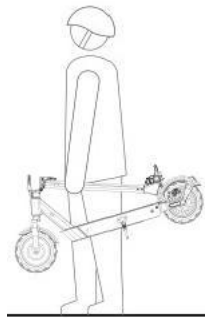

## Daily Care and Maintenance

If you see stains on the scooter, wipe them off with a damp cloth. If the stains won't scrub off, apply some toothpaste and brush them with a toothbrush, then wipe them off with a damp cloth.

**Note:** Do not clean the scooter with alcohol, gasoline, kerosene or other corrosive and volatile chemical solvents to prevent damage. Do not wash the board with a high-pressure water spray. During cleaning, make sure that the scooter is turned OFF, the charging cable is unplugged, and the rubber plug is closed as water leakage may result in electric shock or other major problems. When the scooter is not in use, keep it indoors where it is dry and cool. Do not leave it outdoors for long periods of time. Excessive sunlight, overheating and over-cooling can damage the battery pack and reduce its lifespan.

### Daily Care and Maintenance of Battery:

**1.WARNING:** Never try to remove or replace the battery.

**2.** Contact us if you experience issues relating to riding, maintenance and safety, or errors/faults with your izIP Glide E-Scooter. Call the Customer Service Centre: 1-833-674-0954 (do not return to store)

**3.WARNING:** Do not touch the battery contacts. Do not dismantle or puncture the casing. Keep the contacts away from metal objects to prevent a short circuit, which may result in battery damage, or even injuries and deaths.

**3.WARNING:** only use original power adapter (charger) to avoid potential damage or fire.

**4.WARNING:** Mishandling of used batteries may do tremendous harm to the environment. To protect the natural environment please follow local regulations to properly dispose of used batteries.

5. After every use, fully charge the battery to prolong its lifespan.

## Daily Care and Maintenance

### Storage:

1. Please try to store the scooter in a cool and dry place between 14°F and 104°F (-10 °C and 40 °C). In extremely humid environments, the interior of the scooter may experience condensation or even water accumulation, which may damage the battery or other internal components.
2. In daily use try to avoid completely depleting the battery. If the battery is low, charge it as soon as possible.
3. Please charge the scooter every other month to preserve the battery.
4. TIP: It's important to periodically charge your battery even when not using the scooter often. Charging the battery monthly will help it maintain a longer lifespan (re-charge capacity).

If the brake is too tight, use the hex key (included) to loosen the brake cable anchor screw on the brake caliper at the rear wheel and slightly back the brake cable to shorten the exposed end length, then re-tighten the screw to secure the cable in place. If the brake is too loose, loosen the brake cable anchor screw and slightly pull out the brake cable to lengthen the exposed end length, then finally re-tighten the screw to secure the cable in place.

△ The brake pads in disc brake will wear over time. If the brake is correctly adjusted and still does not feel tight, it may mean that the brake pads have worn. Please call the customer service center: 1-833-674-0954 for advice on how to replace the brake pads.

## Daily Care and Maintenance

### △ Warning!

- Do not ride at night.
- To reduce the risk of injury, adult supervision is required.
- Never use in roadways, near motor vehicles, on or near steep inclines or steps, swimming pools or other bodies of water; always wear shoes, and never allow more than one rider.
- Protective equipment should be worn, e.g. helmet, gloves, knee-pads, elbow-pads. Do not use in transit.
- Not suitable for children under 14 years.
- Contact with (molten material, soleplate heating element) may cause burns.
- To prevent electric shock, do not immerse in water, and do not use the product after it has been wet.
- Please use the specified adapter to charge, which was sold with the e-scooter together.
- Only ride on smooth, paved surfaces away from motor vehicles.
- Avoid sharp bumps, drainage grates, and sudden surface changes.
- Avoid streets and surfaces with water, sand, gravel, dirt, leaves, and other debris.
- Avoid excessive speeds especially when riding downhill.
- Check and secure all fasteners before every ride.

**CAUTION:** Do not disassemble, heat above 100° C (212°F), or INCINERATE as risk of fire and burns may occur.

# Specifications

Motor	500W
Battery	Lithium-ion, 36V/15Ah
Length of charging time	7-8 hours
Display	LED
Riding Modes (Electric Motor Power Output) Switch between the different speed modes by dicking the power button.	Green = Beginner Mode(max 15 km/h or 9.3 mph) White =Intermediate Mode(max25 km/h or 15.5 mph) Red = Sport Mode(max 32km/h or 19.8 mph)
Max Rider Weight	220 Lbs(100kg)
*Average* Max Speed	32 km/h(19.8 mph)
*Average* Max Slope (percentage)	15%
*Average* Max Range	37~40 km(22.99~24.85 miles)
Charger	110~240V
Frame material	Aluminum Alloy/ABS/PC
Wheel size	10" (25.4cm)
Tires	Solid Rubber
Dimensions (folded)	Length x Width x Height= 47.24"x18.89"×21.25" 120×48×54cm
Dimensions(after unfolding)	Length x Width x Height = 47.24"x18.89"x47.63" 120x48x121 cm
Weight	43.65 lbs 6 oz(19.8kg)
Note: The Items above in asterisk(*)suggest an average rider weight, and ideal conditions while riding on a smooth, flat surface. Therefore, these are subject to vary depending on factors:	*Average* Max Speed *Average* Max Slope(percentage) *Average* Max Range
Working temperature	-10~40° C
Charging temperature	-10~40° C

## Limited Product Warranty

The manufacturer's warranty covers the body of the e-scooter for a period of 12 months from date of purchase, and for 6 months for the charger and battery ("Warranty Period"). Replacement parts will be provided to the end user at no cost to them on any quality related issues within the applicable Warranty Period with valid proof of purchase.

### Exclusions

This product is not guaranteed against wear and tear (including grips, tires, brakes, lights). [This warranty is only offered on iZIP products sold in Canada] The warranty does not cover damages resulting from misuse or abuse of the product and/or uses inconsistent with the Owner's Manual, attempts at repair, theft, use with unauthorized attachments or failure to follow the instructions provided with the product. This warranty becomes void if attempts at repair are made by non-authorized third parties and/or if spare parts, other than those provided by manufacturer, are used.

### Disclaimers

You acknowledge the inherent risks of use of operating an electric scooter and you assume the risk and liability for loss, damage, or injury to you and your property and/or to others and their property arising out of the misuse or abuse of the product or failure to follow instructions provided by the manufacturer in the accompanying Owner's Manual. The manufacturer shall not be liable for incidental, consequential, special or contingent damages resulting from its breach of this written warranty or any implied warranty. There are no other express warranties except as set forth herein and any applicable implied warranties of merchantability and fitness (or those provided for by law) are limited in duration to the period of coverage of this express written limited warranty.

### How to Obtain Warranty Service

**Note: For all warranty claims, please call the Warranty Service Centre at 1-833-674-0954**

A Warranty Service order must be requested within the applicable Warranty Period from the date of purchase, and must include original receipt as proof of purchase. To request a Warranty Service Order, contact the Customer Service Centre: 1-833-674-0954.

Canadian Tire Corporation

Toronto, Ontario, Canada, M4S 2A9

## Questions and Answers

**1.What if the E-Scooter arrived missing an accessory or with a broken part?**

A:Please call the Customer Service Centre by dialing the number at the bottom of this page.

The Support Team will then assist you with the proper steps for replacement parts.

**2. Is it possible to replace some components for example the rear cover?**

A: Yes. Please call the Customer Service Centre by dialing the number at the bottom of this page.

The Support Team will then assist you with the proper steps for replacement parts.

If you still have questions with folding the scooter, please call the Customer Service Centre at 86 579 88030579.

## Contact Us

**SToe** Please read entire owner's manual prior to use.

Contact us if you experience issues relating to riding, maintenance and safety, or errors, faults, or quality with your iZip Glide E-Scooter.  
Customer Service Cent: 86 579 88030579

FCC Statement:

This device complies with part 15 of the FCC Rules. Operation is subject to the following two conditions:

- (1) This device may not cause harmful interference, and
- (2) this device

must accept any interference received, including interference that may cause undesired operation.

This equipment has been tested and found to comply with the limits for a Class B digital device, pursuant to part 15 of the FCC Rules. These limits are designed to provide reasonable protection against harmful interference in a residential installation. This equipment generates, uses and can radiate radio frequency energy and, if not installed and used in accordance with the instructions, may cause harmful interference to radio communications. However, there is no guarantee that interference will not occur in a particular installation. If this equipment does cause harmful interference to radio or television reception, which can be determined by turning the equipment off and on, the user is encouraged to try to correct the interference by one or more of the following measures:

- Reorient or relocate the receiving antenna.
- Increase the separation between the equipment and receiver.
- Connect the equipment into an outlet on a circuit different from that to which the receiver is connected.
- Consult the dealer or an experienced radio/TV technician for help.

Caution: Any changes or modifications not expressly approved by the party responsible for compliance could void the user's authority to operate the equipment. This equipment complies with FCC radiation exposure limits set forth for an uncontrolled environment. This transmitter must not be co-located or operating in conjunction with any other antenna or transmitter.