



# E-SCOOTER APP



App Store

Download "Circooter" app from App Store (iPhone)/Google Play (Android) or scan the QR code to and install the app. Then connect your phone to the scooter.

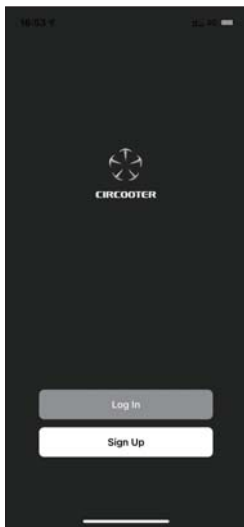

1. Open the APP and enter the main page, Click Sign up

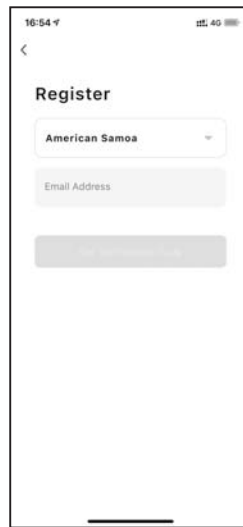

2. Select country and enter your email



3. Find the verification code sent by us in your mailbox, Fill in the verification code



4. Set a password for your account

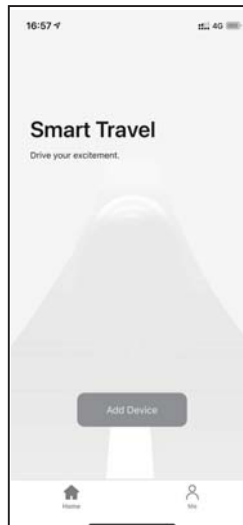

5. Account registration is complete, start your riding experience immediately



## Assemble

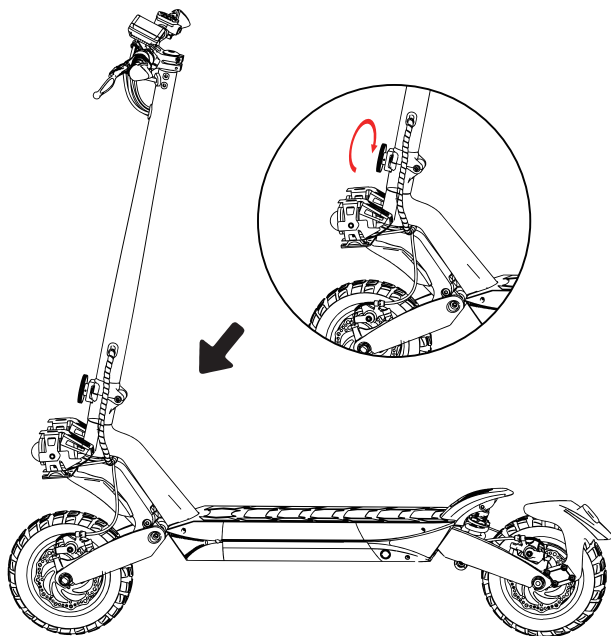

1. Close the folding plug, buckle the lock, and twist the lock.

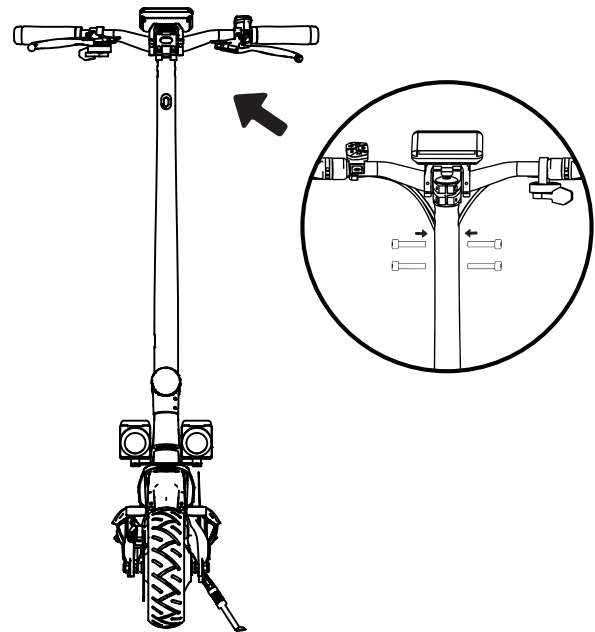

2. Insert the handlebar assembly into the fold large tube and lock the 4 screws.



## Attention

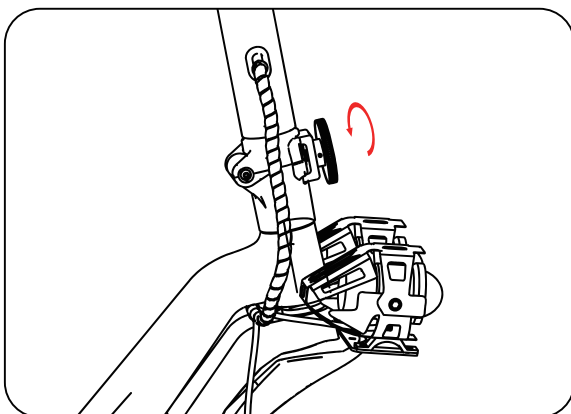

1. Turn the fold connector knob counterclockwise until the fold connector buckle no longer holds the connector.

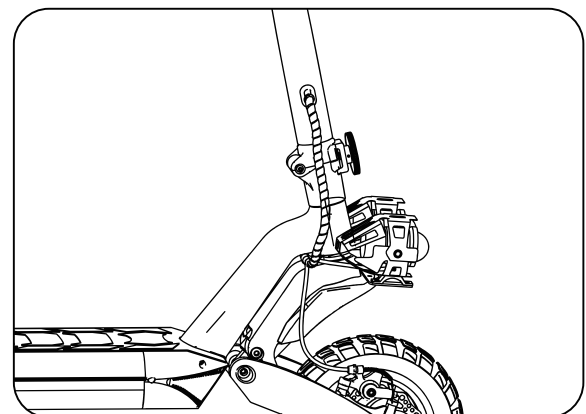

2. Fold the handlebars and tubes to the rear.



# Riding Basics

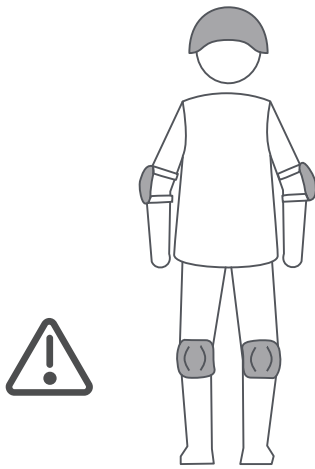

Wear a helmet, elbow pads, and knee pads in case of falls and injuries either you are a beginner learning to ride or you are a seasoned rider.

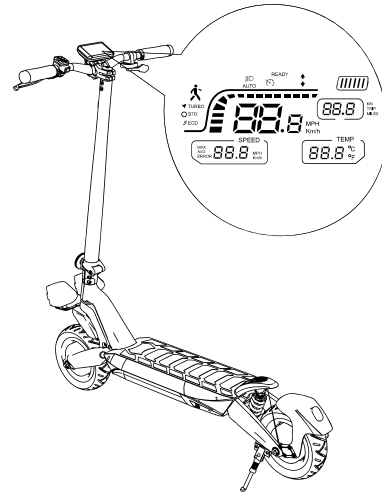

- 1 Turn the power on, and check the battery level indicator.

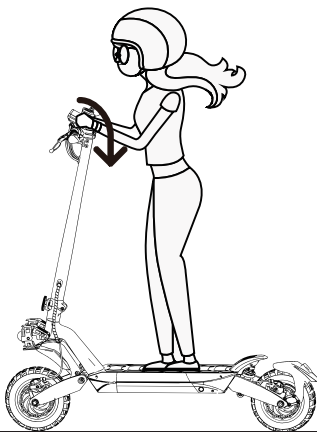

- 2 Stand with one foot on the deck and one foot on the ground. Scoot yourself with the foot on the ground.

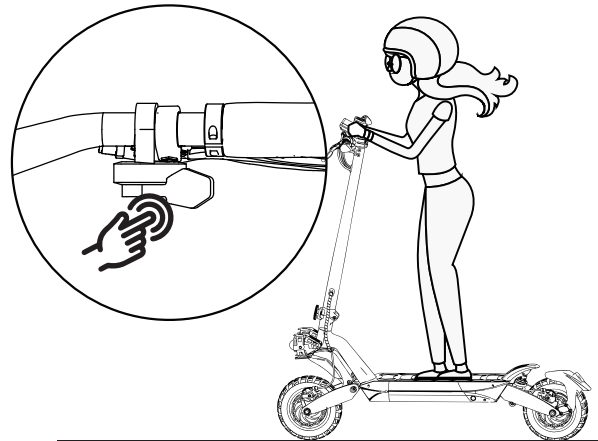

- 3 When the scooter starts to move forward, put both feet on the deck and press the accelerator. (The accelerator initiates once the speed exceeds 3 mph.)

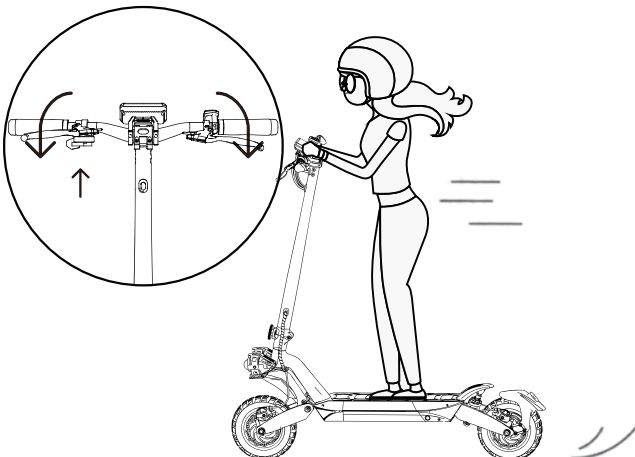

- 4 Release the accelerator and the kinetic energy recovery system (KERS) initiates automatically to brake slowly; And squeeze the brake lever for a sudden brake.

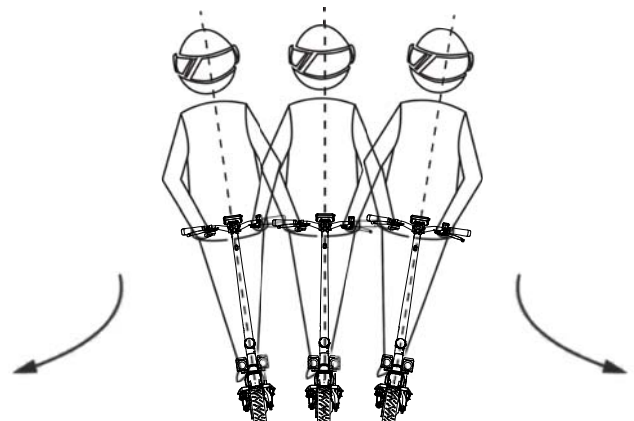

- 5 Tilt your body to the steering direction as you turn, and slowly turn the handlebar.



## Riding Notice



 Do not ride in the heavy rain.

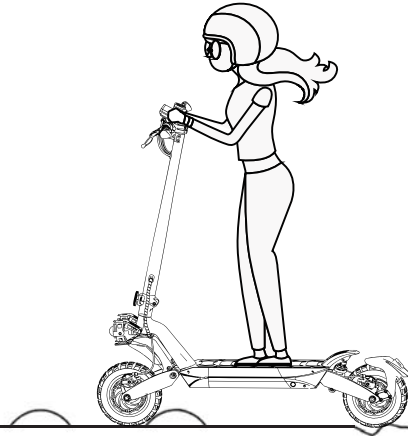

 Please keep a medium or low speed ( mph) when you ride through speed bumps, elevator door sills, bumpy roads or other uneven surfaces Slightly bend your knee to better adjust mentioned surfaces.

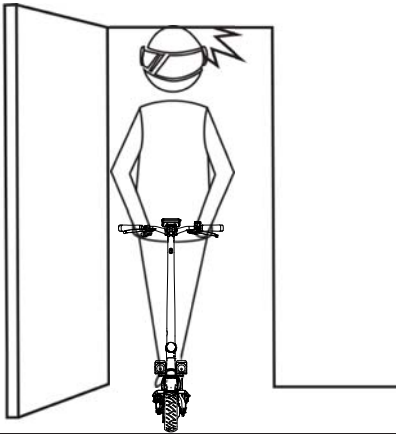

 Look out for doors, elevators and other overhead obstacles.



 Do not accelerate when you go downhill.



 Do not press the accelerator when you're walking alongside the scooter.

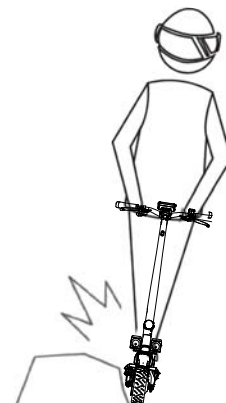

 Always steer clear of obstacles.



## Riding Notice



⚠ Do not hang heavy stuff on the handlebar.

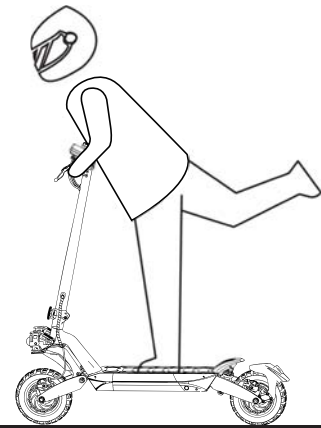

⚠ Keep both feet on the deck all time.



## Dangerous Actions

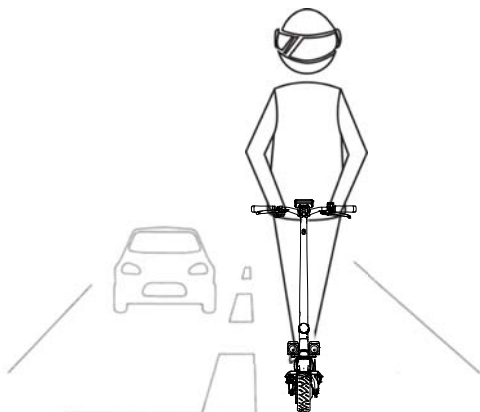

⊘ Do not ride in traffic lanes or residential areas where vehicles and pedestrians are both allowed.

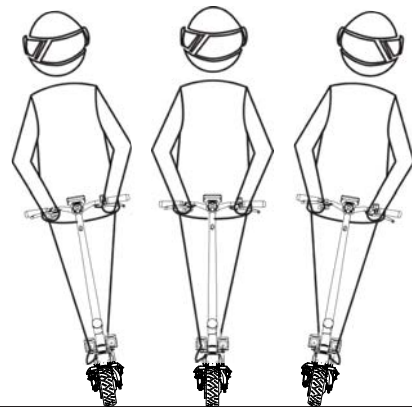

⊘ Do not turn the handlebar violently during high-speed riding.



⊘ Do not ride in a ponding that is higher than 2 INCH.

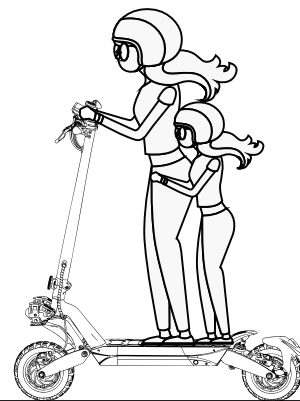

⊘ Do not ride with anyone else, including children.



## Dangerous Actions

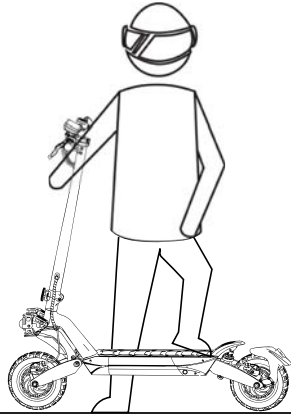

⊘ Don't step on the rear mudguard.



⊘ Always keep your hands on the handlebar.

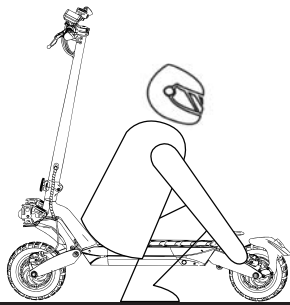

⊘ Do not touch the disc brake.

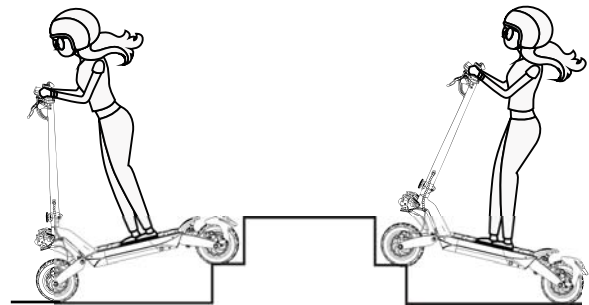

⊘ Do not try riding up or down stairs, and jumping over obstacles.



## Charging

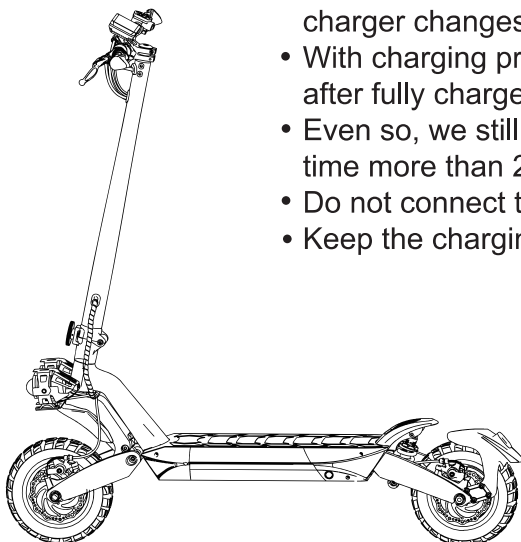

- Your scooter will be fully charged when the LED indicator on the charger changes to green from red.
- With charging protection, it will cut off charging automatically after fully charge.
- Even so, we still don't recommend charging your scooter for a long time more than 24 hours at one time.
- Do not connect the charger if the charging port is wet.
- Keep the charging port closed when not charging.

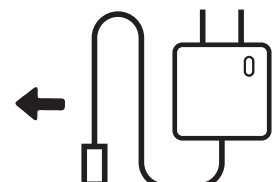
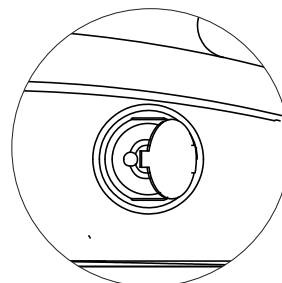



# Disc Brake Adjustment

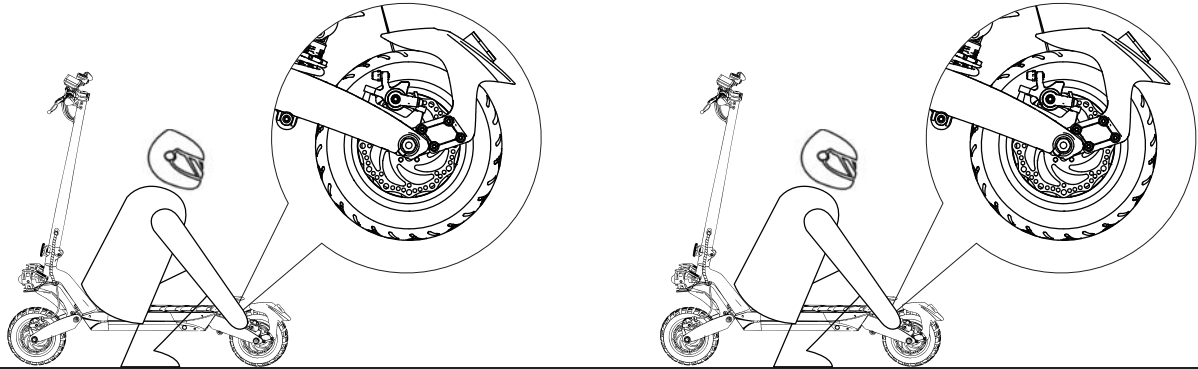

To adjust the disc brake sensitivity:

You need a hex wrench to remove the screws on the rocker.

- When the disc brake is too sensitive, rotate the disc brake rocker down a bit. Then, reinstall the screws back to the brake cable core to tighten.
- When the disc brake cannot stop, rotate the disc brake rocker up a bit. Then, reinstall the screw back to the brake cable core to tighten.

Notice: The disc brake may squeak when in use until it is broken in. This is normal and does not affect the brake's function or performance.

To remove the disc brake noise,

First make sure the scooter is turned off. For easier operating, we suggest you put the scooter on the desk.

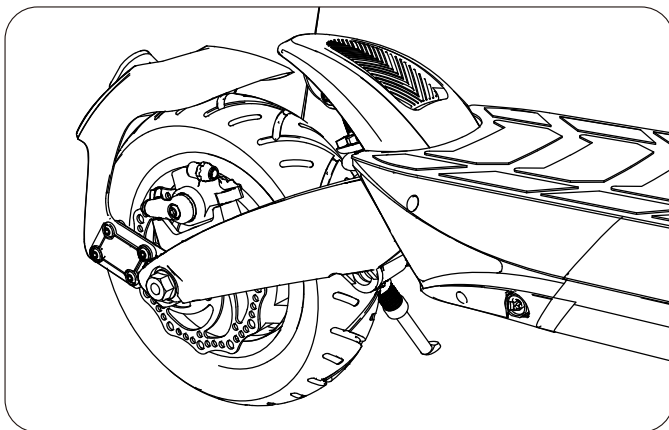

- Loosen two screws on the pump (not the screw on the rocker).
- Adjust the position of the disc brake pump to ensure that the brake disc is in the middle of the two brake pads.
- Keep the brake disc and brake pad not touching each other.
- Hold the disk brake pump in the desired position, then re-tighten the screws to the pump.



# Safety Instructions



## Cleaning and Storage

If you see stains on the scooter's body, wipe them off with a damp cloth. If you cannot scrub off the stain, put on some toothpaste, and brush them with a toothbrush, then wipe them off with a damp cloth.

### Notes :

- Do not clean the scooter with alcohol, gasoline, kerosene, or other corrosive and volatile chemical solvents to prevent dire damage.
- Do not wash the deck with a high-pressure water spray. During cleaning, make sure that the scooter's turned off, the charging cable is unplugged, and the rubber flap is closed as water leakage may result in electric shock or other major problems. When the scooter is not in use, keep it indoors where it is dry and cool.
- Do not put it outdoors for a long time. Excessive sunlight, overheating, and over-cooling will shorten the battery pack's lifespan.

## Battery Maintenance

- ① Use original battery packs. Use of batteries of other models or brands may bring about safety issues;
- ② Do not touch the contacts. Do not dismantle or puncture the casing. Keep the contacts away from metal objects to prevent short circuit which may result in battery damage or even injuries and deaths;
- ③ Use original power adapter to avoid potential damage or fire;
- ④ Mishandling of used batteries may do tremendous harm to the environment. To protect natural environment, please follow local regulations to properly dispose used batteries.
- ⑤ After every use, fully charge the battery to prolong its life span.

## Storage and Disposal

- ① Please try to store the scooter in a cool and dry place between 14°F and 104°F. In extremely humid environments the interior of the scooter may suffer condensation or even water accumulation, which may damage the battery rapidly. Devices are not intended for use at elevations greater than 2000 m above sea level. Prolonged Exposure to UV Rays, Rain and the Elements May Damage the Enclosure Materials, Store Indoors When Not in Use.
- ② In daily use, try to recharge the scooter after completely exhausting the battery. If the battery level is low, charge it as soon as possible.
- ③ Please charge the scooter every other month to preserve the battery.





# Limited Warranty Statement

## 30 DAY SATISFACTION GUARANTEED RETURN POLICY

If you are unsatisfied with your purchase, Circooter's return policy allows you to return the product purchased on the Authorization channel within 30 days counting from the date of receipt of shipment, and request a refund from the Authorization channel for any reason.

Note: Express shipping cost is non-refundable.

For the return request, Circooter is not responsible for lost packages due to the carrier, or products received that cannot be verified. Received products that have damage determined to have been caused by the end-user may be subject to denial of the return request.

## TO QUALIFY FOR A REFUND, ALL THE FOLLOWING CONDITIONS MUST BE MET

- 1 A Return Merchandise Authorization (RMA) must be requested from Circooter within 30 days from the date of receipt of shipment. To request an RMA, contact Circooter Service Team at [hello@circooter.com](mailto:hello@circooter.com).  
The cost of return shipping will be borne by the customer.
- 2 For warranty service, please keep your receipt and/or invoice to validate proof of purchase.
- 3 Returned product must be in good physical condition (not physically broken or damaged).
- 4 All accessories originally included with your purchase must be included with your return.
- 5 If you return a product to Circooter, (a) without an RMA from Circooter (b) without all parts included in the
- 6 original package, Circooter retains the right to refuse delivery of such return.

## LIMITED PRODUCT WARRANTY

Circooter warrants the original purchaser that your Circooter product shall be free from defects in materials and workmanship under normal use for a period aforementioned.

Circooter does not warrant the operation of the product will be uninterrupted or error-free.

Circooter is not responsible for damage arising from failure to follow instructions relating to the product's usage.

## REMEDIES

If a hardware defect is found and a valid claim is received by Circooter within the Warranty Period, Circooter will, at its option and to the extent permitted by law, either (1) repair the product at no charge, using new or refurbished replacement parts or, (2) replace the product with a new or refurbished product. In the event of a defect, to the extent permitted by law, these are your sole and exclusive remedies. Shipping and handling charges may apply except where prohibited by applicable law. This Limited Warranty is valid only in the jurisdictions where the products are sold by [hello@circooter.com](mailto:hello@circooter.com), and is valid to the extent permitted by the applicable laws of such jurisdictions.

Any replacement hardware product will be warranted for the remainder of the original warranty period or thirty (30) days, whichever is longer, or for any additional period of time that may be applicable in your jurisdiction.

## HOW TO OBTAIN WARRANTY SERVICE

A Warranty Service Order must be requested from Circooter within Warranty Period from the date of receipt of shipment. To request a Warranty Service Order, contact Circooter Service Team [hello@circooter.com](mailto:hello@circooter.com).

To obtain warranty service, you must deliver the product, in either its original packaging or packaging providing an equal degree of protection, to the address specified by Circooter. In accordance with applicable law, Circooter may require the customer to furnish proof of purchase details and/or comply with registration requirements before receiving warranty service. period or thirty (30) days, whichever is longer, or for any additional period of time that may be applicable in your jurisdiction.



## Error Code

Error code	Reason	Maintenance and treatment
4	Short-circuit fault	Check if there is a wrong wire connection or if there is a short circuit in the installation, remove the short circuit or replace the controller
9	Secondary motor communication has failed	Check whether the connection line between the secondary controller and the main controller is well connected.
10	Dashboard communication has failed	Check whether the instrument panel and controller assembly cables are normal, turn off, remove the assembly line interface, check the plug-in for slanting and loosening, and insert again after processing. Power on, replace instrument or controller.
11	Motor current sensor is abnormal	Check the motor and the phase line portion of the controller
14	Accelerator Hall exception	Check whether the accelerator is completely reset, check whether the accelerator and connection line are normal, can disconnect the acceleration connection line, and restart to exclude exceptions.
15	The brakes put Hall abnormal	Check whether the brake handle is completely reset, can pull out the electronic brake cable, restart, troubleshooting.
16	Motor Hall exception	Start-up fault, check whether the motor Hall wiring is normal, shut-off, pull out the assembly line interface and check whether the plug-in is crooked, or bad contact, correct, restart and troubleshooting
19	Secondary motor Hall exception	Check the secondary motor Hall wiring for normal, check the replacement motor or controller to eliminate problems
21	The BMS communication is abnormal	
50	Bus line high voltage	The voltage of the main line is too high, and the fault is turned on. You should check whether the battery voltage is normal and faulty during cycling. You should replace the battery or controller to eliminate the problem
53	System overload	Beyond the system load, restart, start up failure, the controller should be replaced to eliminate the problem
55	Controller high temperature alarm	The controller temperature is too high, static let the car to cool and then restart. If the startup fails, replace the controller to eliminate the problem.



## FAQS

### 1 What if the E-Scooter is arrived with missing accessories or broken parts?

A: Please take a photo and send to Circooter Support Team by sending email: And Circooter Support Team will reply you soon and send correct accessory or part replacement.

### 2 Is the tire replaceable and how to replace the tire?

A: Yes, the tire is replaceable. Please contact Circooter support team for more information or search the video "How to replace the offroad tire" in YouTube instead.

### 3 What if the rear disc brake of the scooter doesn't work well?

A: You may please contact us for instructions of brake adjusting, or search "How to adjust rear brake of scooter" in YouTube for tutorial video as well.

### 4 What if the rear disc brake of the scooter doesn't work well?

It usually means your disc brake tilts to cause friction noise. Please see Disc Brake Adjustment page. If you still have problem, please contact us for help.

### 5 Why does the display an error code?

If you see any error code above, Please contact Circooter Support Team to remove the error code.





## Contact Us

Contact us if you experience issues relating to riding, maintenance and safety, or errors/faults with your Circooter electric scooter.

 E-mail Service: [hello@circooter.com](mailto:hello@circooter.com)

 [www.Circooter.com](http://www.Circooter.com)

 Facebook: [@CIRCOOTER](https://www.facebook.com/CIRCOOTER)

 ins: Circooter

 Youtube: Circooter

 1-833-597-1988

FCC Statement:

This device complies with part 15 of the FCC Rules. Operation is subject to the following two conditions:

- (1) This device may not cause harmful interference, and
- (2) this device

must accept any interference received, including interference that may cause undesired operation.

This equipment has been tested and found to comply with the limits for a Class B digital device, pursuant to part 15 of the FCC Rules. These limits are designed to provide reasonable protection against harmful interference in a residential installation. This equipment generates, uses and can radiate radio frequency energy and, if not installed and used in accordance with the instructions, may cause harmful interference to radio communications. However, there is no guarantee that interference will not occur in a particular installation. If this equipment does cause harmful interference to radio or television reception, which can be determined by turning the equipment off and on, the user is encouraged to try to correct the interference by one or more of the following measures:

- Reorient or relocate the receiving antenna.
- Increase the separation between the equipment and receiver.
- Connect the equipment into an outlet on a circuit different from that to which the receiver is connected.
- Consult the dealer or an experienced radio/TV technician for help.

Caution: Any changes or modifications not expressly approved by the party responsible for compliance could void the user's authority to operate the equipment.

This equipment complies with FCC radiation exposure limits set forth for an uncontrolled environment. This transmitter must not be co-located or operating in conjunction with any other antenna or transmitter.