

# Robotic Vacuum Cleaner V8

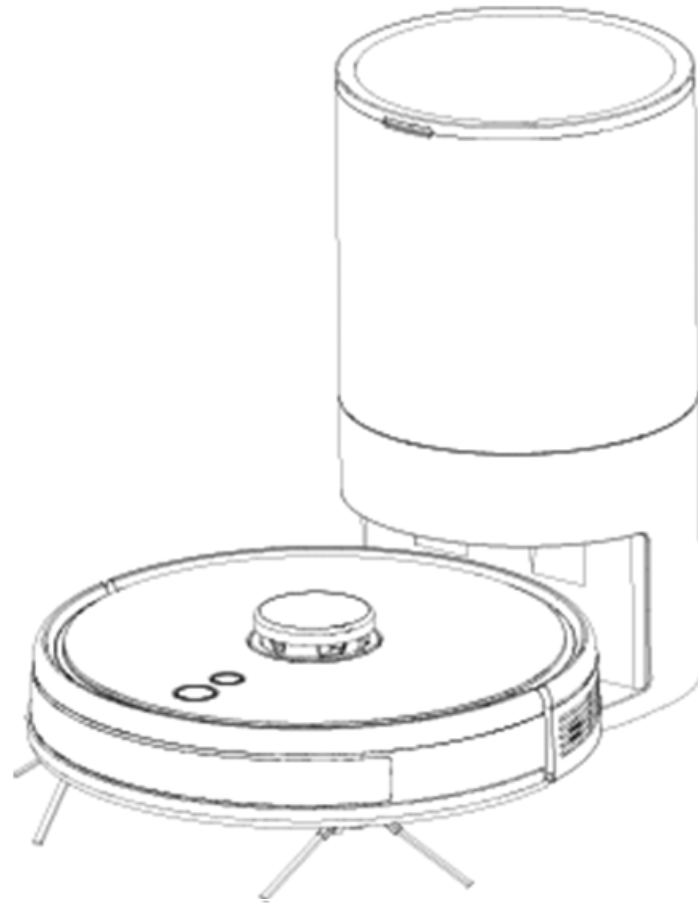

Please read this manual carefully before use and keep it properly

# Welcome to use

Thanks for choosing Smart Robot Vacuum Cleaner and Dust Collector!

It is a high-end intelligent planning cleaning robot which combines high accuracy radar and various sensors can realize collaboration through navigation algorithm, draw a room map in real time and plan the cleaning route and features automatic cleaning and automatic charging without manual intervention. It has ultrastrong suction power, high-capacity drawer type dust box, washable HEPA filter screen and split type mopping module and adopts an efficient cleaning mode of first cleaning and then mopping.

You can download the mobile APP by smart phone to check the cleaning map and running status of the robot in APP in real time, define the cleaning area and schedule. You can control the robot remotely. Science and technology makes life better.

Free your hands and collect dust with one button.

May you have a nice usage experience!

# Product Introduction

## Key Function

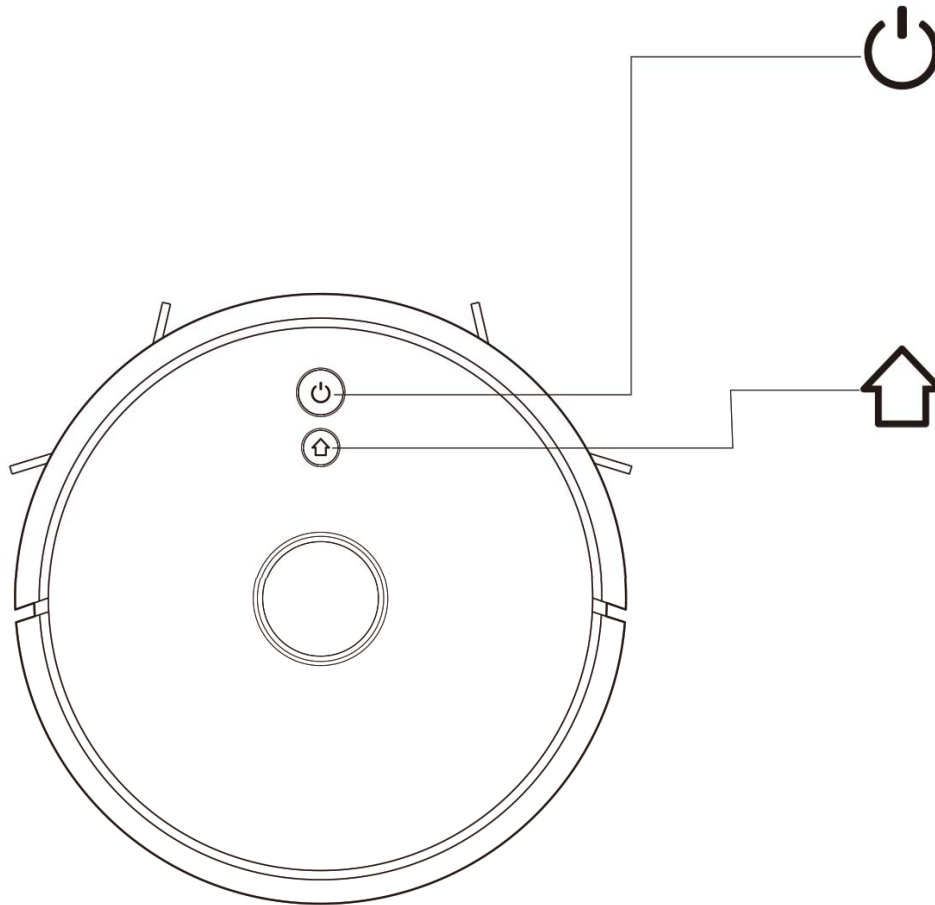

### Sweep / ON&OFF

- Short press to start Sweep/Pause
- Long press for 3s for ON/OFF
- Long press for 15s for forced shutdown under abnormal circumstances

### Recharging/ local cleaning

- Short press Recharge/Pause
- Long press to start local cleaning

### Indicator light

- Blue: Normal operation or charging
- Red: Abnormal condition or low battery
- Purple: Equipment is not connected to the network

### Reset WiFi

- Press two buttons simultaneously for 3s

# Product Introduction

## Parts List

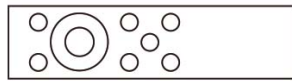

Remote control X1(optional)



Cleaning brush with knife X1(optional)

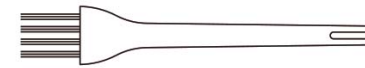

Cleaning brush X1(optional)

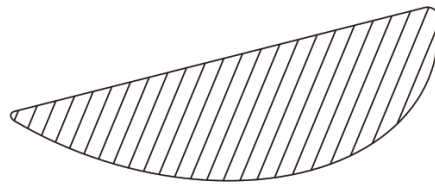

Duster clothX1

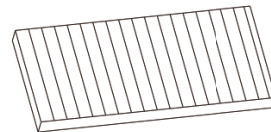

HEPA filter+sponge filterX1

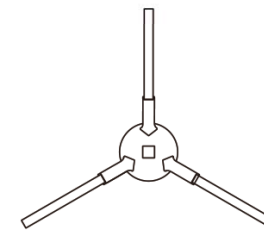

Left side brushX2  
Right side brushX2

# Product Introduction

## Parts List

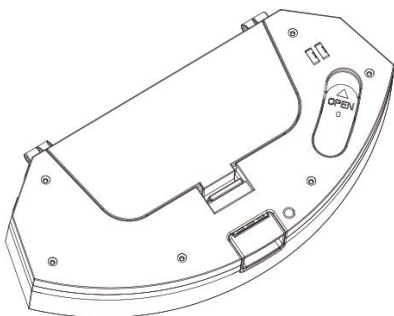

2 in 1 pump water tank dust box X1

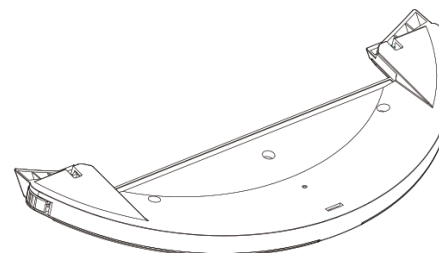

Mopping bracket X1(optional)

# Product Introduction

Robot

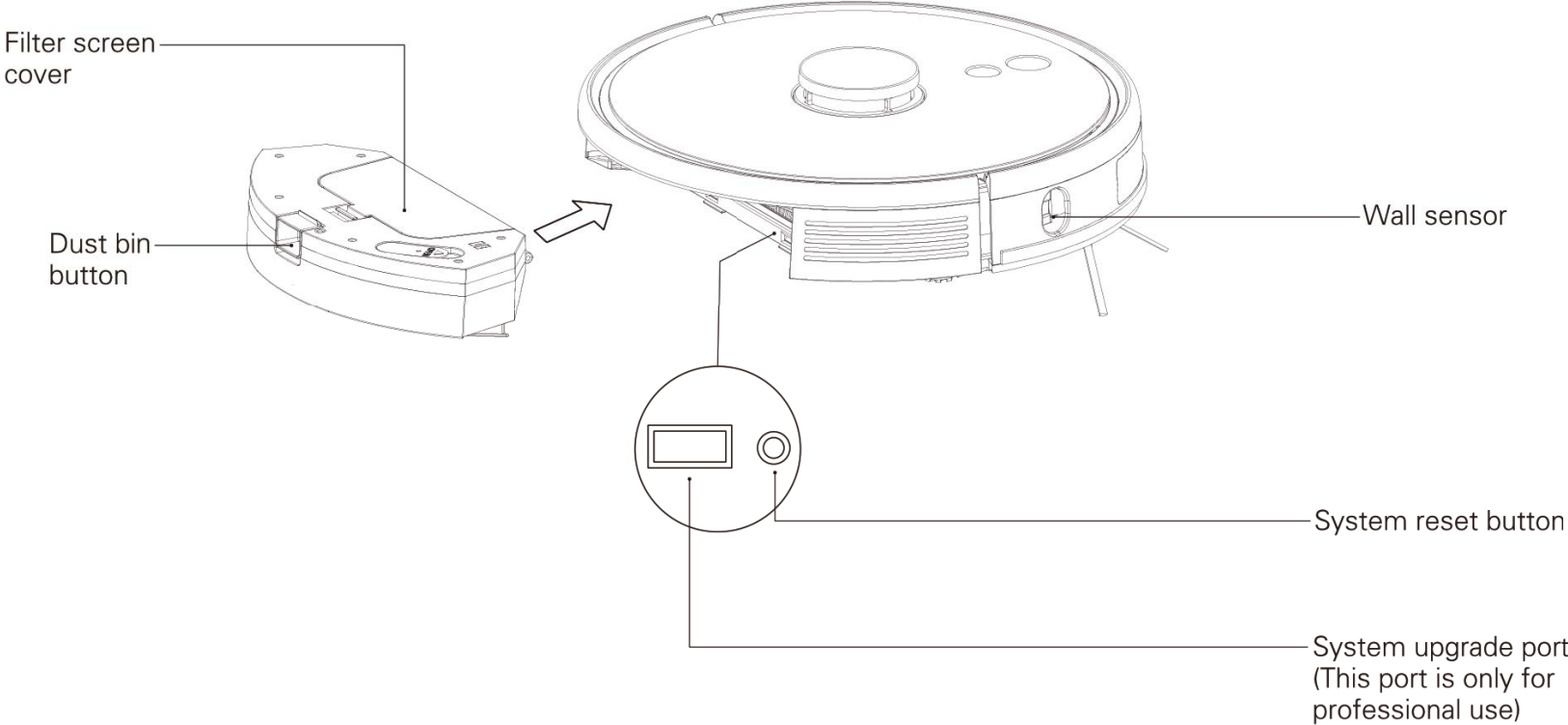

# Product Introduction

## Sensor and Structure

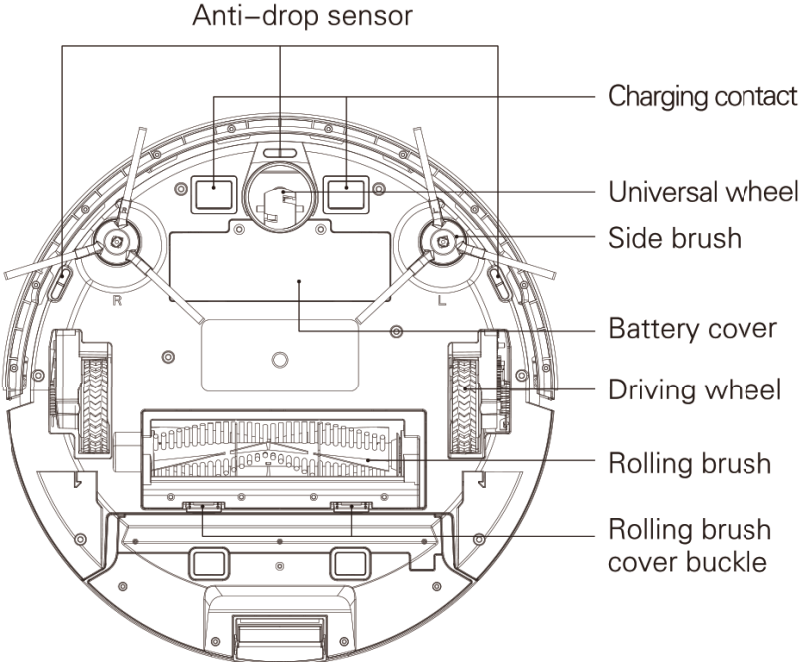
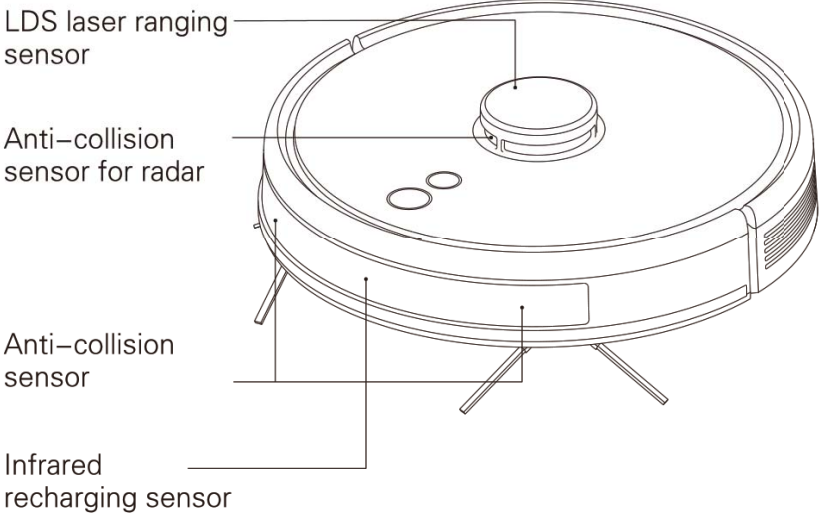

# Product Introduction

Dust Collector (Dust collection and charging combo)

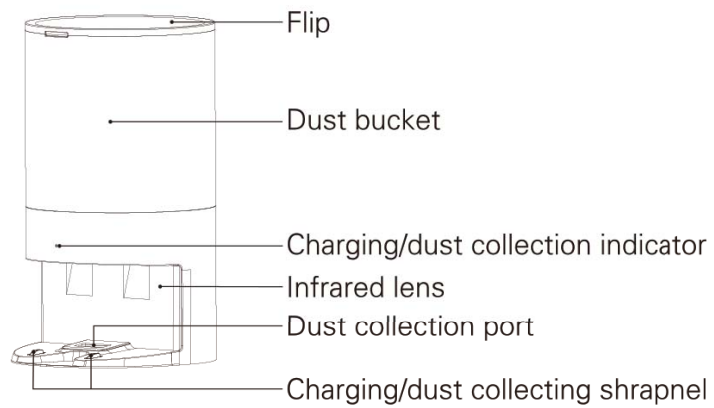

Front of Dust Collector

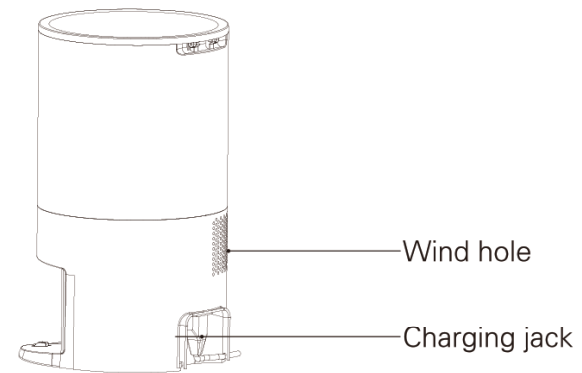

The back of dust collector



# Installation

## 1、Installation of side brush

Make the left side brush (L) and the right side brush (R) correspond to L and R on the bottom casing, press L and R and the side brushes are installed till you hear a “cracking” sound

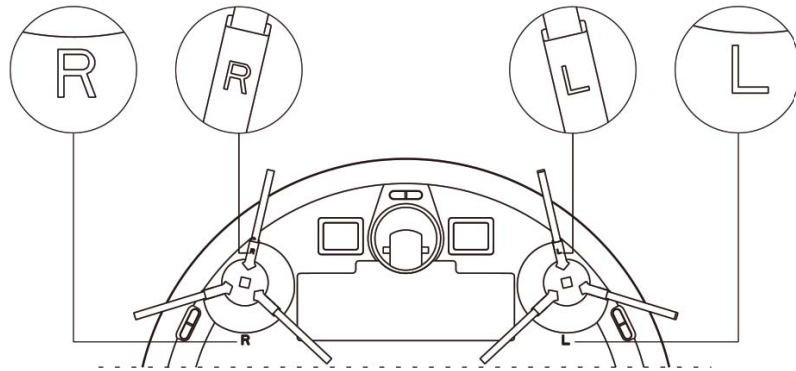

## 2、Install dust collector

① The dust collector is more than 6 cm away from the wall and placed on a flat ground

0.06m from the wall

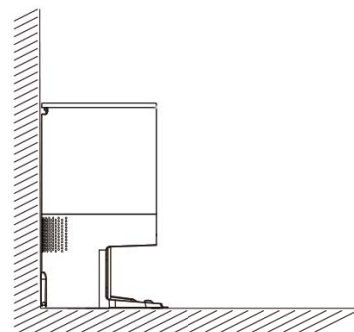
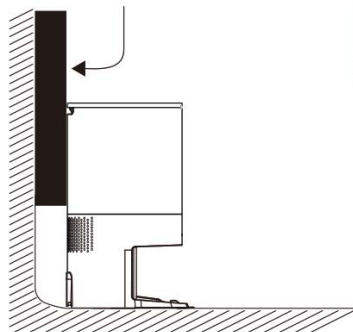

# Installation

- ② Ensure that there is more than 1.5 meters in front of the dust collector and more than 0.5 meters on both sides

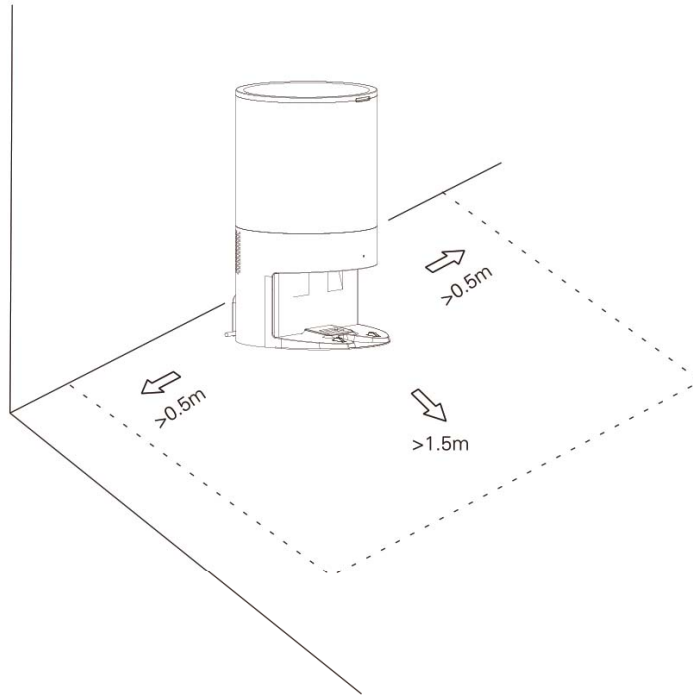

## Tips:

- If you choose a charging base, please ignore the installation of the dust collector
- If the charging base and the dust collector exist at the same time, please place them in separate rooms to avoid interference

# Installation

## 4、Starting up and charging

Long press  to switch on the robot. Charge the robot on charging base or dust collector when the power indicator light is normally on

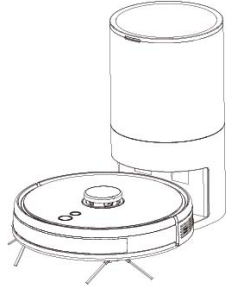

Note : If the machine cannot be started due to low battery, please charge the host on the charging base or dust collector and the machine will be started automatically. The machine can work normally only when the battery level is  $\geq 20\%$

## 5、Connect mobile APP(this step can be skipped)

Please refer to WiFi connection guideline, then connect mobile APP



## 6、Start cleaning

After the robot is powered on, short press key  on the robot or use mobile APP to start cleaning.(press any button to pause during using)

Note:

- The sweeping robot cannot be used to remove liquids
- If the battery level is less than 20, the machine cannot work. Please charge it
- The machine will return to the charging base automatically if the battery level is less than 20% in use and will be powered off and start cleaning automatically after the battery level reaches 80%
- Please clear various wires (including power line of charging base) on the ground before use so as to avoid outage and damage of objects or wires when wires are dragged by the host

## 7、Install the mopping module and the 2 in 1 water pump tank dust

① Install the rag: smoothly stick the rag to the bottom of the mopping bracket

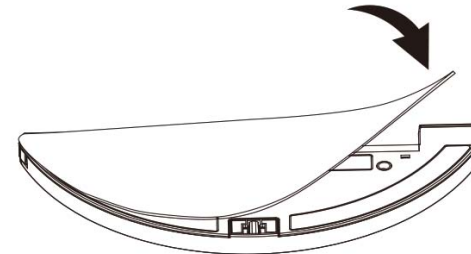

Mopping bracket

Note: please clean the mopping cloth after using to keep it in good cleaning condition

② Fill the water tank: uncap the cover and fill with water

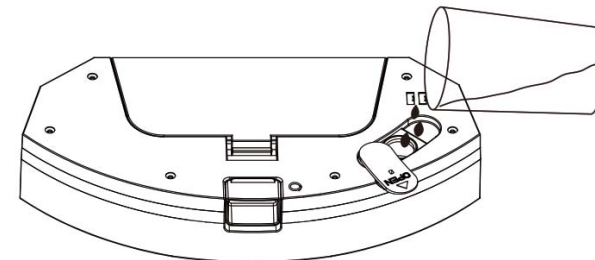

2 in 1 pump water tank dust box

# Installation

③ Intall the module: Push the module horizontally along the rear part of the robot. The module is installed in place if you hear a "click" sound

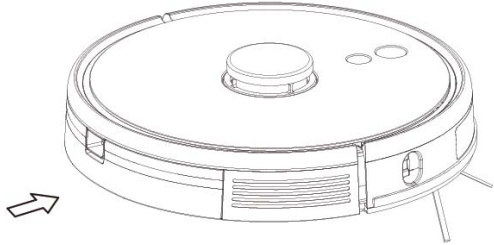

2 in 1 pump water tank dust box

## 8、Remove the mopping module

When the robot is finished working, press the clasp on both sides, remove the mopping module backwards, empty the water in water tank, and clean the mopping cloth (do not move or turn the robot over during cleaning)

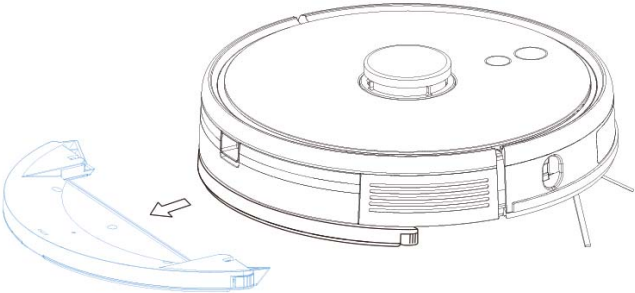

Mopping bracket

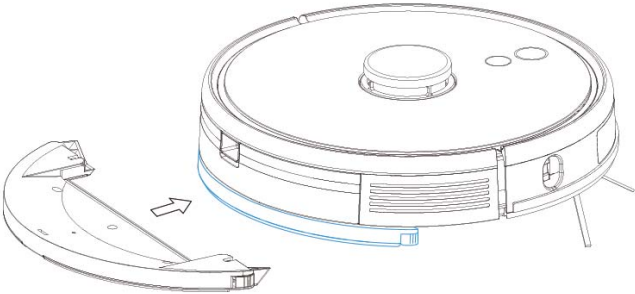

Mopping bracket

When the robot is finished working, press the button in the middle of the water tank to remove the mopping module backwards, empty the water in the water tank and clean the mopping cloth (do not move or turn the robot over during cleaning)

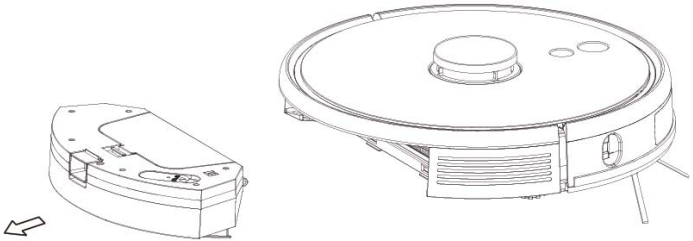

2 in 1 pump water tank dust box

# Installation

## 9、Instructions for mopping module

- ①Please do not use the mopping module when it is left unused
- ②For the sake of safety, please be sure to remove the mopping module when it is being charged or left unused
- ③Please do not mop the carpet. Set a forbidden area in APP to prevent the machine from entering the carpet
- ④To achieve a better mopping effect, the mopping module should be installed after the floor is swept for three times
- ⑤To add water or clean the dust cloth when the machine works, please pause it, and take out and reassemble the mopping module according to steps 8 and 9. Please do not move or turn over the host so as to avoid failing in positioning and losing the map
- ⑥Mopping function of the machine is intended for wiping and is conducive to deep cleaning. it cannot remove stubborn stain effectively and replace labor force

# Instructions

## ON/OFF

Long press  key for 3s, the indicator light is on and the machine is started

Long press  key for 3s when the machine is under standby mode, the indicator light is off and the machine shuts down

Note : The machine cannot shut down when the host is being charged

## Sweep/Pause

After the machine is started, short press  key on the host or start the machine using mobile APP

( Press any key to pause in use )

Note :

- The cleaning robot cannot be used to remove liquids
- If the battery level is less than 20, the machine cannot work. Please charge it
- The machine will return to the charging base automatically if the battery level is less than 20% in use and will be powered off and start cleaning automatically after the battery level reaches 80%
- Please clear various wires (including power line of charging base) on the ground before use so as to avoid outage and damage of objects or wires when wires are dragged by the robot

## Charging

Automatic mode : The robot will return to the charging base automatically after work

Manual mode: Under suspended state, short press  key to start recharging or when the recharging host is charged under the control of mobile APP, The indicator light is under breathing mode when the recharging host is charged

Note : if the robot can not find the charging base, it will automatically return to the starting position. Please manually put the robot back to the charging base for charging

# Instructions

## Cleaning mode

After the robot is powered on, it will scan and generate the map and divide it into areas intelligently. Then sweep the areas one by one along the wall orderly, efficiently and thoroughly and plan the cleaning route in a bow/S shape. The robot will return to the charging base automatically after cleaning

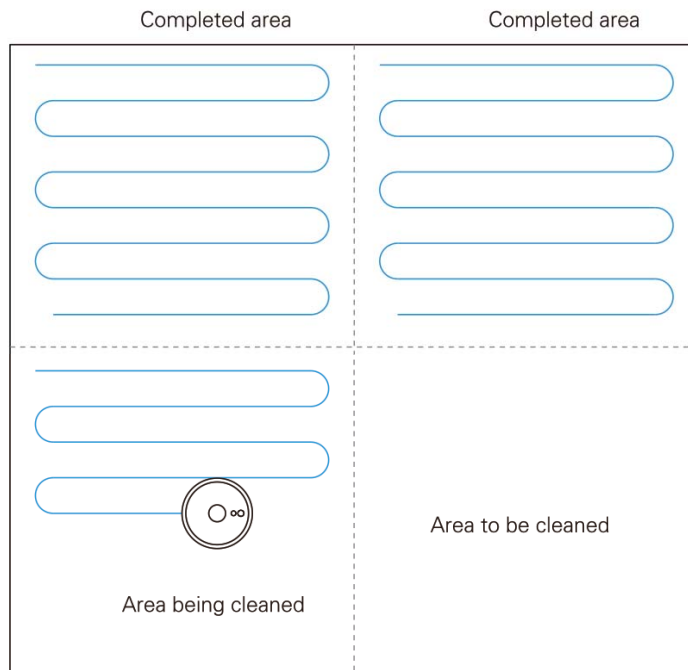

### Note:

Do not move the robot casually and frequently when it is cleaning. After moving, please put the robot near the original position. When it starts again, it will try to reposition itself. After successful positioning, it would follow the planned path and continue to work. If the positioning fails, the robot would abort previous mission, make a map and do the cleaning again. Even it maynot find the charging base

## Spot cleaning

When a local area needs a deep sweep, the user specifies a point on the map on the APP, the machine will automatically drive to the vicinity of the point, take the point as the center, and clean within 1.5m x 1.5m

## Partial cleaning

When the robot cannot be controlled by the mobile APP, please remove the robot to the place you want to clean. Long press the  button for 3 seconds, and the robot will clean twice within the scope of 1.8mx1.8m centering on itself

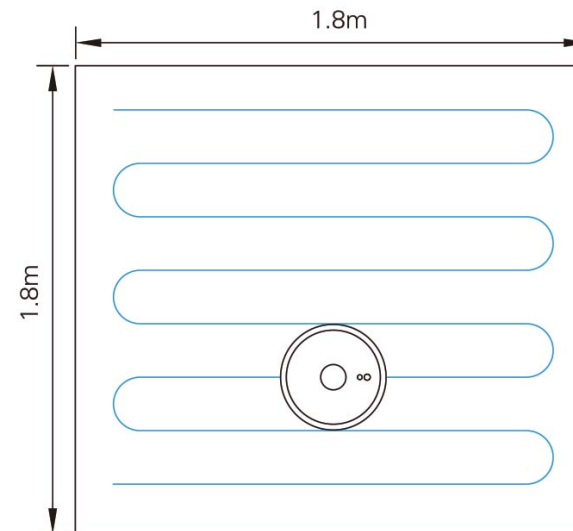

# Instructions

## User-defined area cleaning

Use the mobile APP to set the size and location of the area you want to clean. You can set one or more areas. The robot would clean according to the areas you set

## Restricted area

Set one or more forbidden areas using mobile APP. The robot will not sweep forbidden areas but other areas



Note :

- The robot may intrude into the restricted area due to positioning errors, abnormal sensors and other reasons.
- The permanent closed zone may become invalid due to the big change of the position of the charging seat and furniture. Therefore, please try not to move or interfere with the robot during cleaning.
- The permanent restricted area would be lost when the map is rebuilt

## Schedule cleaning

Schedule cleaning can be set by mobile APP. The robot will start cleaning automatically at the appointed time and return to the charging base after cleaning.

## WiFi reset

If the mobile phone cannot be connected to the machine due to modification of router configuration and password or for other reasons, please press  key and  key simultaneously for 3s till a voice prompt "WiFi has been reset" is given and the indicator light turns purple and flickers slowly



## DND mode

The robot will neither sweep the floor nor issue a voice automatically under DND mode. The available time of DND mode can be startup or modified using mobile APP

## Adjustment of suction power

You can adjust the suction power to silent level, standard level and high level by mobile APP

## Adjustment of water flow

You can adjust the water flow to low level, standard level and high level by mobile level

# Instructions

## Remote control instruction

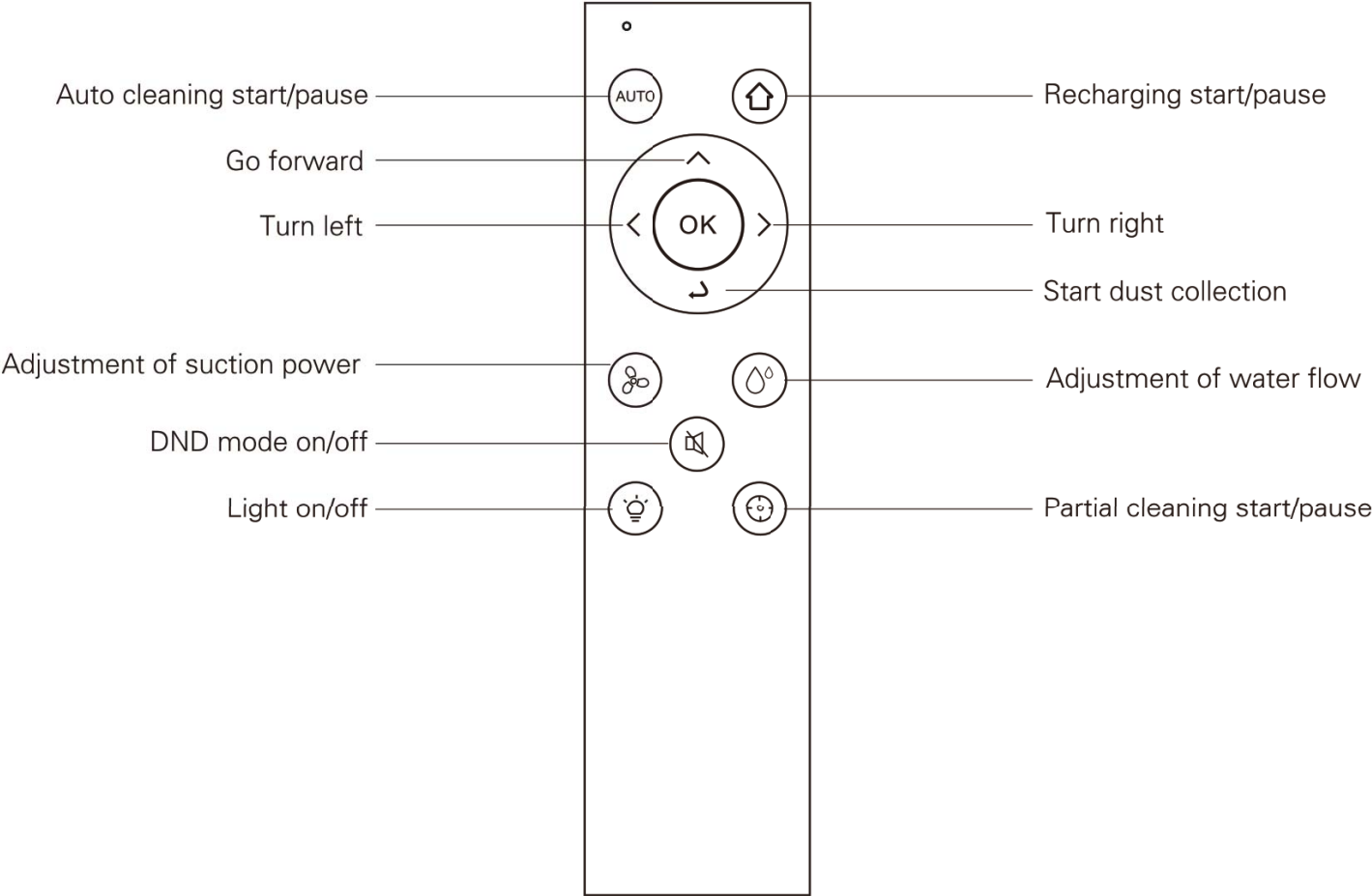



# Daily maintenance

## Rolling brush (clean it regularly)

1. Turn over the machine and press the buckle on the Rolling brush cover to take out the Rolling brush
2. Remove dust outside and inside the Rolling brush using tiny brush and clean the Rolling brush
3. Reassemble the Rolling brush and press the Rolling brush cover tightly to fix the buckle

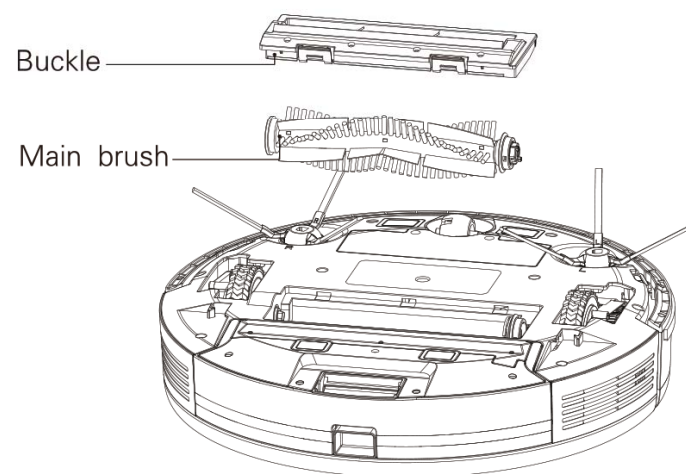

## Side brush (clean it regularly)

1. Turn over the machine and pull out the side brush upwards
2. Remove hair and dirt and reassemble the side brush
3. Make the left side brush (L) and the right side brush (R) correspond to L and R on the bottom casing, press L and R to reinstall them

Note : Replace the side brush every 3-6 months so as to ensure the cleaning effect

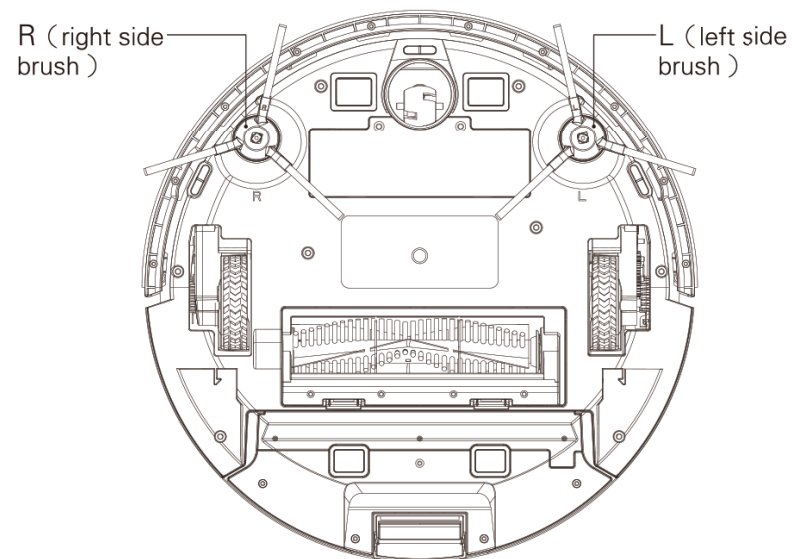

# Daily Maintenance

## 2 in 1 pump water tank dust box (clean it regularly)

1. Press the dust box release button to pull out the dust box of the 2 in 1 water pump tank

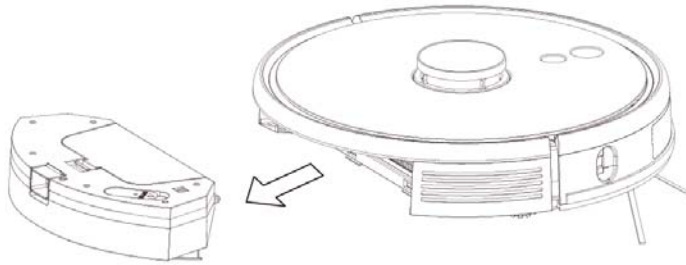

2. Open the flip cover of the dust box to empty the trash

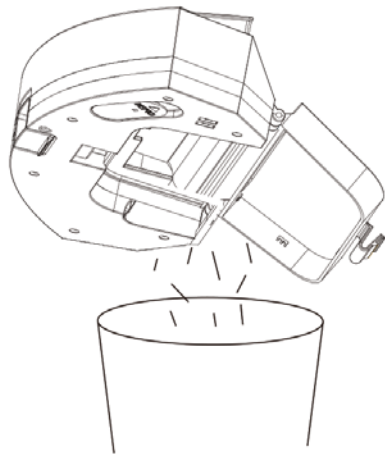

## Filter screen cleaning (clean it regularly)

1. After a long time usage, remove the filter gauze, sponge and HEPA
2. Clean the removed filter gauze, sponge and HEPA under water
3. Shake off the water drops and dry it naturally, then use it after completely dried
4. After dry, install it well in sequence, filter gauze - sponge - HEPA

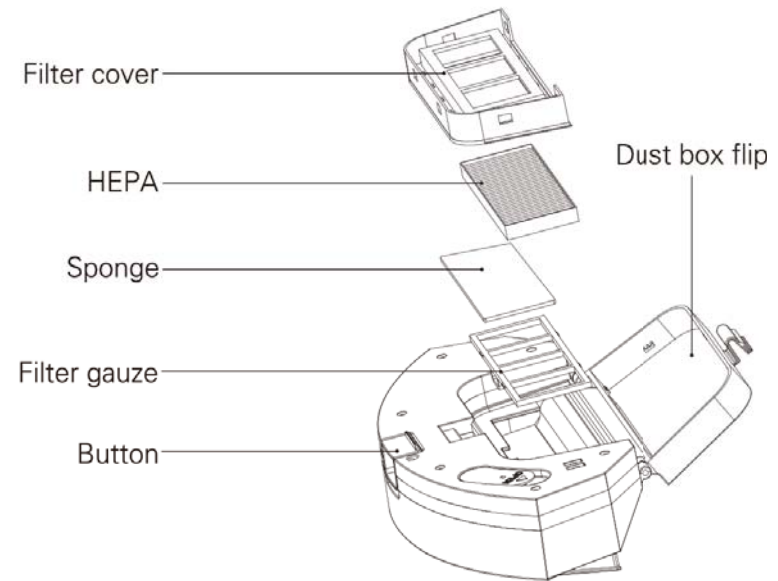

# Daily Maintenance

## Mopping module ( cleaned it every time )

1. Remove the rag from the mopping assembly

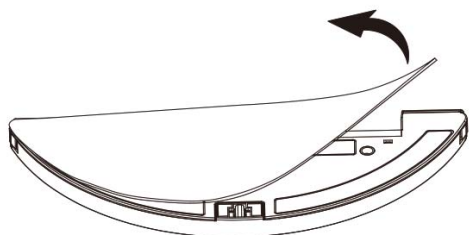

2. Clean the rag, dry the water tank and the rag, and wait for the next use

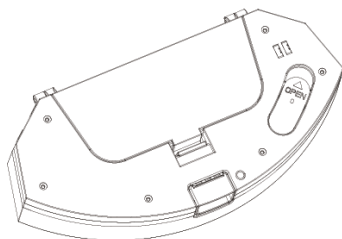
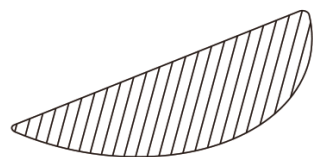
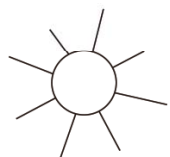

2 in 1 pump water tank dust box

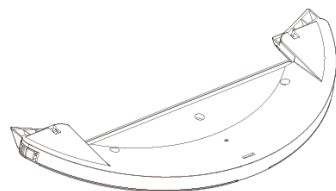

Mopping bracket

## Sensor ( cleaned it every time )

Clean the sensors by soft mop, include:

1. Clean the sensors along the wall on the right
2. Three anti-dropping sensors at the bottom of the host
3. Infrared avoidance sensor in the front of the host
4. Radar avoidance sensor on the top of the host
5. Electric shock protector and charging base shrapnel at the bottom of the host (please cut of the power during cleaning)
6. Signal transmission area of charging base

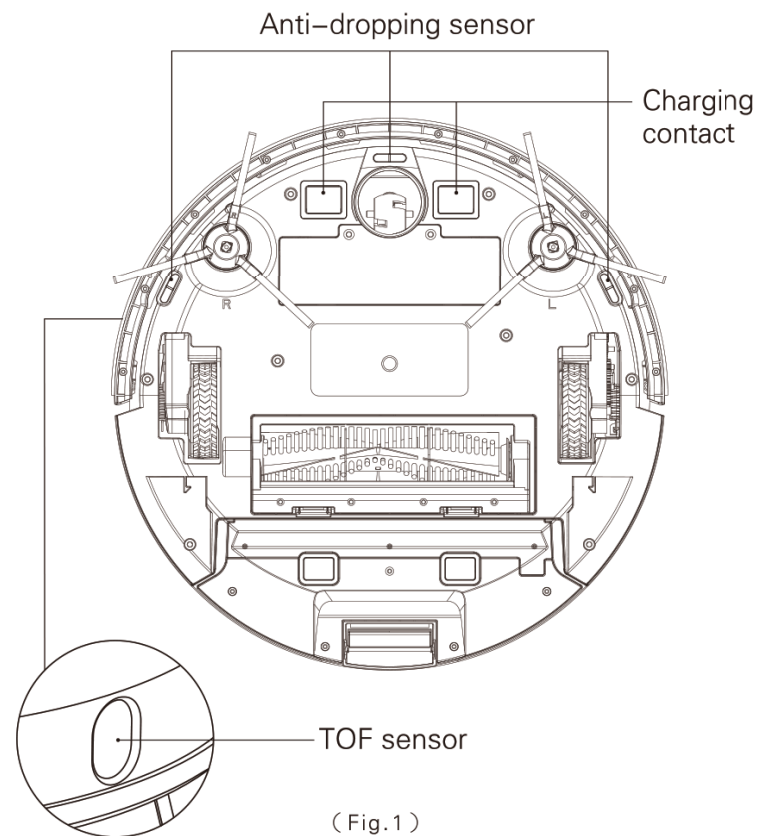

( Fig.1 )

# Daily Maintenance

Sensor (cleaned monthly)

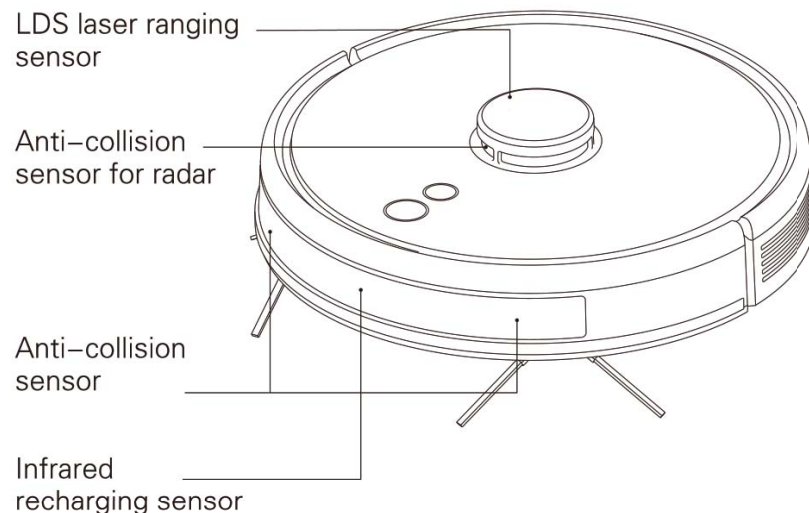

( Fig.2 )

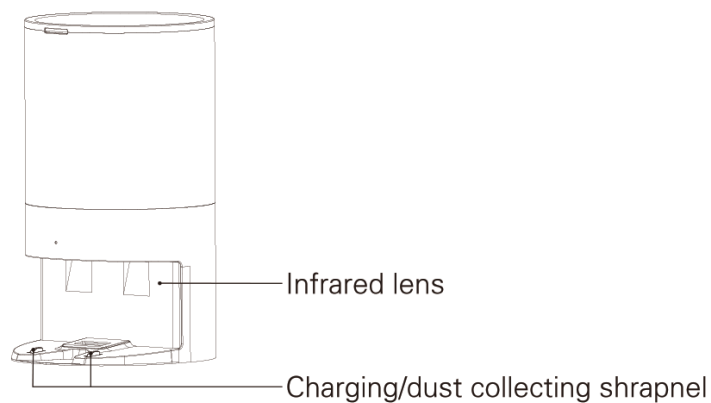

( Fig.3 )

## Battery

- The host is furnished with high-performance lithium-ion batteries. To maintain battery performance, please keep the host charged in daily use
- If the machine is left unused long, please shut down and keep it properly. Charge it at least every 3 months to avoid damaging batteries due to excessive discharge

## Firmware upgrade

Upgrade firmware using mobile APP. If new firmware is detected, upgrade it according to prompt. The battery level should be  $\geq 50\%$  during firmware upgrade, so the machine should be placed on the charging base

## System reset

Take down the dust box, open the rubber plug and press Reset key (refer to page 4). Current map will be lost and timing, WiFi and personalized settings will be reserved after reset

# Basic Parameters

## Machine

Item	Parameter
Model	V8
Overall dimension	350X350X100mm
Product weight	3.6kg
Li-battery	2500mAh
Rated voltage	14.4V
Rated power	50W

## Dust collector

Item	Parameter
Model	V8
Overall dimension	242X220X393mm
Product weight	3.5kg
Vacuum suction value of dust collector fan	$\geq 25\text{KPa}$
Input voltage	AC 100 — 240V
Dust bag capacity	3L
Fan power	1050W

# Common Problems

Problem	Solution
The robot cannot be started	<ul style="list-style-type: none"> <li>· In case of a low battery level, please place the robot on the charging base and align it at the electrode plate, the machine will be started automatically (if the robot is completely powered off, it can be started automatically after charged for a while)</li> <li>· If the environment temperature is lower than 0°C or higher than 50°C, please use it at a temperature of 0–40°C</li> </ul>
The robot cannot be charged	<ul style="list-style-type: none"> <li>· Please move the robot away, check whether the indicator light of the charging base lights on and confirm both ends of the power adapter of the charging base are connected well</li> <li>· In case of poor contact, please clear the charging base shrapnel and the charging contact on the robot or push the side brush aside</li> </ul>
The robot cannot be recharged	The robot is too far away from the charging base, please put the robot near the charging base and make another try
Abnormal behavior	Shut down and restart the robot
Abnormal noise in use	Main brush, side brush or wheel may be twined by foreign matters, please shut down the robot and remove foreign matters
Cleaning ability declines or dust falls out	<ul style="list-style-type: none"> <li>· The dust box is full, please clear it</li> <li>· The filter screen is blocked, please clear or replace it</li> <li>· The main brush is twined by foreign matters, please clear it</li> </ul>
WiFi cannot be connected	<ul style="list-style-type: none"> <li>· WiFi signal is bad, please ensure is covered by WiFi signal</li> <li>· WiFi is connected abnormally, please reset WiFi, download the latest APP and try to reconnect it</li> <li>· Password is inputted incorrectly</li> <li>· The router is available for 5G frequency band, the cleaning robot is available for 2.4G frequency band only</li> </ul>
Fixed-time cleaning fails	In case of a low battery level, fixed-time cleaning can be started only when the battery level is no less than 30%
Whether the robot consumes power if it is always placed on the charging base	The robot consumes a little power if it is always placed on the charging base and it enables the best performance of battery
Whether the robot needs to be charged for 16h for the first three times	The lithium battery can be used immediately after being charged and has no memory effect

# Troubleshooting

Prompt Tone	Solution
Error 1: Oh dear! I cannot find the dust collector	Cleaning is triggered when the dust box is take out
Error 2: Please check if the radar on top has been covered or blocked	The top radar is covered or placed in an open area (there is not obstacle within an area of 6 × 6m <sup>2</sup> )
Error 3: Please place me in a new location and try again	Pick the robot up or hang it in the air
Error 4: Please scrub the cliff sensor, and restart me from a new location	The cliff sensor is covered or placed at height
Error 5: Please scrub the front sensor, and restart me from a new location	The infrared avoidance sensor is dirty or covered
Error 6: Please scrub the right-hand sensor, and restart me from a new location	The wall sensor is dirty or covered
Error 7: Please scrub the radar housing on top, and restart me from a new location	The radar avoidance sensor is dirty or covered
Error 8: Please check if the bumper has been blocked in some way	The edge or collision sensor is stuck
Error 9: Master, please clean the dust container and filter	The dust box is full or the filter screen needs to be replaced
Error 10: Dust container has been removed, please clean the container and filter	After error 9 is issued, user takes out the duct chamber and error 10 is triggered
Error 11: I'm stuck, please help me!	The robot is stuck

# Troubleshooting

Prompt Tone	Solution
Error 12: Please place me correctly!	The robot is tilt
Error 13: Please check if my wheels have become blocked somewhere	The driving wheel is stuck or twined
Error 14: Please check if the main brush has become stuck	The main brush is twined or stuck
Error 15: Please check if the side brushes have become stuck	The side brush is twined or stuck
Error 16: What's going on? Where is the docking station?	The charging base cannot out found or is not plugged in
Error 17: Oh dear! Program error, please restart me	Abnormalities are caused by unknown breakdown, restart the robot
Error 18: Error encountered initiating shutdown	The robot reminds the user and shuts down automatically or is recharged
Error 19: Low battery, please recharge	When the battery level is too low and the robot is not on the charging base, cleaning is triggered (the battery level is lower than 10%)
Error 20: To shut me down, please place me away from the docking station	The robot shuts down when charged on the charging base
Error 21: Collecting fan motor error	Re–plug the power cord and restart, if it still fails, send it to after–sales service
Error 22: The dust bag is not installed	Please check whether the dust bag has been installed / whether the dust bag is in place



# Content and Name of Hazardous Substances

Hazardous Substance	Part Name					
	Plastic casing	Circuit board	Power line	Battery	Metal part	Adapter
Lead (Pb)	○	×	×	×	○	×
Mercury (Hg)	○	○	○	○	○	○
Cadmium (Cd)	○	○	○	○	○	○
Chromium VI (Cr (VI))	○	○	○	○	○	○
Polybrominated biphenyls (PBB)	○	○	○	○	○	○
Polybrominated diphenyl ethers (PBDE)	○	○	○	○	○	○

Environmental life of components: circuit board components: 10 years; power line: 10 years; battery: 5 years. The environmental life labeled on the product refers to the safe service life of the products in leakage of which hazardous and noxious substances will not be caused under service conditions specified in the User Manual

○ :means that the content of hazardous and noxious substances in the component is less than the limit stipulated by SJ/T11363-2006

×

✕ :means that the content of hazardous and noxious substances in at least the component exceeds the limit stipulated by SJ/T11363-2006



Note:

The lead content of a few paste electronic components for special use (such as high voltage resistor, ceramic resistor and diode, etc.) in “X” in the table may be greater than 0.1%. Core of bolt and the lead content of high-performance alloy contained in USB cable also may be greater than 0.1%. Such components comply with exemption clauses of EU ROHS. For technologies and components which cannot be replaced due to restrictions of technological development level, the lead content of external contact elements complies with environmental protection requirements

# Safety Information

## Usage Limitations

- The product is used for floor cleaning in a home environment only and cannot be used for outdoor (such as open terrace), non-ground (such as sofa) and commercial or industrial environment
- Please do not use the product in midair areas (such as penthouse, open terrace and furniture top) without protective fence
- Please do not use the product at a temperature of above 40°C or below 0°C or when there are liquids and sticky substances on the ground
- Please hang cables on the ground before use so as to avoid being dragged by the host
- Please clear fragile objects and impurities (such as vase and plastic bag, etc.) on the ground so as to avoid damaging valuables when the host is stuck or impacted slightly
- People with physical, spiritual or perceptual disorder (including children) are not allowed to use or operate the product
- Children cannot use the product as a toy. Please keep children and pets away when the host is working
- Please keep main brush and other cleaning tools out of reach of children
- Please do not place objects (including children and pets) on a stationary or moving machine.
- Please keep hair, fingers and other parts of human body or pets away from the suction inlet when the machine is works
- Please do not use the product to sweep burning objects (such as burning cigarette end)
- Please do not use the product to clean long-haired carpet (some dark carpets may not be cleaned normally)
- Please prevent the host from suctioning hard or sharp objects (such as waste decorative materials, glass and iron nail, etc.)
- Please do not move the machine by holding the protective cover of laser distance sensor and collision bumper
- Please clean or maintain the host and the charging base under shutdown or power-off state
- Please do not wipe any part of the product using wet cloth or any liquid
- Please use the product according to User Manual. User should be responsible for any damages and injuries caused by improper use
- Please do not use mopping function for carpet and furniture top
- Please be sure to remove the water tank when the machine is being charged

# Safety Information

## Battery and Charging

- Please do not use battery, charging base or charger provided by any third parties
- Please do not dismantle, report or refit battery or charging base arbitrarily
- Please keep the charging base away from heat source (such as heating plate)
- Please do not wipe or clean the charging base shrapnel using wet cloth or wet hand
- Please do not abandon used batteries arbitrarily. Used batteries should be disposed of by professional recycling agency
- If power line is damaged or broken, please disuse it immediately and replace it through official channels
- Please ensure the host shuts down during transportation and the product should be transported in original packaging
- If the machine is left unused long, it should be fully charged and then placed in a cool and dry place. Charge the machine at least every 3 months so as to avoid damaging batteries due to excessive discharge

## Laser Safety Information

- Laser distance sensor of the product complies with the standard for class1 laser products of IEC60825 and does not produce dangerous laser radiation

# Safety Information

## Dust Collector

- Please do not leave appliance when plugged in. Unplug from outlet when not in use and before servicing.
- Please do not use outdoors or on wet surfaces.
- Please do not allow to be used as a toy. Close attention is necessary when used by or near children.
- Use only as described in this manual. Use only manufacturer's recommended attachments.
- Please do not use with damaged cord or plug. If appliance is not working as it should, has been dropped, damaged, left outdoors, or dropped into water, return it to a service center.
- Please do not handle plug or appliance with wet hands.
- Please do not put any object into openings.
- Please do not use with any opening blocked; keep free of dust, lint, hair, and anything that may reduce air flow.
- Keep hair, loose clothing, fingers, and all parts of body away from openings and moving parts.
- Turn off all controls before unplugging.
- Please do not use to pick up flammable or combustible liquids, such as gasoline, or use in areas where they may be present.
- Please do not pick up anything that is burning or smoking, such as cigarettes, matches, or hot ashes.
- Please do not use without dust bag and filters in place.
- This appliance is not intended for use by persons (including children) with reduced physical, Sensory or mental capabilities, or lack of experience and knowledge, unless they have been given supervision or instruction concerning use of the appliance by a person responsible for their safety.
- Children should be supervised to ensure that they do not play with the appliance.
- The appliance is only to be used with the power supply unit provided with the appliance.
- This product only be supplied by SELV.

# Warranty Policy

## Warranty Period

- 1.If the product has any performance failures set out in Product Performance Failure Table of Smart Robot Vacuum Cleaner within 7 days as of the date received and upon detection of Intelligent After-sales Center, free changing or refunding service will be provided.
- 2.If the product has any performance failures set out in Product Performance Failure Table of Smart Robot Vacuum Cleaner within 8–15 days as of the date received and upon detection of Intelligent After-sales Center, free changing or maintenance service will be provided.
- 3.If the product has any performance failures set out in Product Performance Failure Table of Smart Robot Vacuum Cleaner within 12 months as of the date received and upon detection of Intelligent After-sales Center, free maintenance service will be provided.

Friendly reminder: To guarantee safety of packaging box during transportation, packing box should be reserved for at least 30day as of the date received

## Warranty content

Name	Content	Warranty Period
Host	Host (including built-in lithium battery )	1year
Dust collector	Dust collector	1year
Accessories	power line and 2 in 1 pump water tank dust box	1year
Consumables	Main brush, side brush, main brush cover, filter screen, main brush cleaning tool, duster cloth	/

Note: Warranty service will not be provided for consumables attached to the machine

# Warranty Policy

## Non-warranty Clause

- 1.Unauthorized maintenance, misuse, collision, negligence, abuse, penetration of liquid , accident, alteration and incorrect use of other accessories, or tearing up, altering label and false proof mark
- 2.The validity period of “three guarantees” expires
- 3.Damages caused by force majeure
- 4.Other failures than performance failures set out in Product Performance Failure Table of Smart Robot Vacuum Cleaner
- 5.Man-made performance failures of the product and accessories set out in Product Performance Failure Table of Smart Robot Vacuum Cleaner and Dust Collector

## Performance Failure Table of Wangjia Smart Robot Vacuum Cleaner and Dust Collector

Name	Performance failure
Host	Functions set out in the Specification are invalid
	The host cannot be started
	The main brush, side brushes, draught fan and main wheel do not work
Dust collector	Dust collection function fails, Fan failure
Adapter	The charging base cannot be powered on

# Three Guarantees

## User Information

Name : \_\_\_\_\_

Tel : \_\_\_\_\_

Add : \_\_\_\_\_

E-mail : \_\_\_\_\_

## Product Information

Model : \_\_\_\_\_

Color : \_\_\_\_\_

Serial No. : \_\_\_\_\_

Order date : \_\_\_\_\_

## Maintenance Record

No.	Date	Fault Phenomenon and Elimination Method	Engineer
1			
2			
3			
4			

## FCC Warning

This device complies with part 15 of the FCC Rules. Operation is subject to the following two conditions: (1) This device may not cause harmful interference, and (2) this device must accept any interference received, including interference that may cause undesired operation.

Any Changes or modifications not expressly approved by the party responsible for compliance could void the user's authority to operate the equipment.

This equipment has been tested and found to comply with the limits for a Class B digital device, pursuant to part 15 of the FCC Rules. These limits are designed to provide reasonable protection against harmful interference in a residential installation. This equipment generates uses and can radiate radio frequency energy and, if not installed and used in accordance with the instructions, may cause harmful interference to radio communications. However, there is no guarantee that interference will not occur in a particular installation. If this equipment does cause harmful interference to radio or television reception, which can be determined by turning the equipment off and on, the user is encouraged to try to correct the interference by one or more of the following measures:

- Reorient or relocate the receiving antenna.
- Increase the separation between the equipment and receiver.
- Connect the equipment into an outlet on a circuit different from that to which the receiver is connected.
- Consult the dealer or an experienced radio/TV technician for help.

FCC RF exposure statement:

The equipment complies with FCC radiation exposure limits set forth for an uncontrolled environment. This equipment should be installed and operated with minimum distance between 20cm the radiator your body.

**Experience Intelligent Technology and Enjoy a High-quality Life**