

Part acknowledgement

Full name of supplier: Dongguan Jerice Technology Co., Ltd.

Address of supplier: 96 Long Wu Road, Tai Ling Shan, Dongguan (3F, building L, Kam Hung Tat Science and Technology Park)

Name of material: : Watch coil

Material specifications: Soft magnetic 25 * 2.6MM 0.08 * 24P 7.7UH-8.0UH single stranded double layer with N52 magnetic force 3400GS ± 200GS with adhesive L=7MM

Type and model: _____

Customer name : Luoxin Electronics

Customer data: E28-00021

Sample delivery time: 2023.7.20

Notes: New materials: Alternative:

Acknowledge the results	<input type="checkbox"/> Qualified <input type="checkbox"/> Disqualified
	Reasons for non-conformance:
	Acceptance of non-conformance and sample handling: <input type="checkbox"/> Return purchase <input type="checkbox"/> Disposal

Signature of supplier		
Applicant	Quality	Approved
Lu Lin	Liang Meixiang	Lu Rusheng
Recognition Stamp		
Date: 2023.7.20		

Recognize the signature				
Applicant	Tester	Project	Quality	Approved
Recognition Stamp				
Date: _____				

一、Table of contents

- 1. Cover.....Page 1-1
- 2. Table of contents.....Page 2-2
- 3. Product drawings.....Page 3-3
- 4. Size Map.....Page 4-4
- 5. Product parameters.....Page 5-5
- 6. Technical requirements.....Page 5-5
- 7. Electrical parameters.....Page 5-5
- 8. Packaging.....Page 6-6
- 9. Bill of materials.....Page 7-7

二、 Product drawing:



三、Plan structure diagram A plan: unit:MM

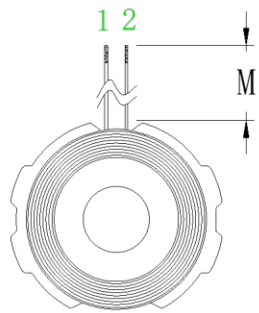
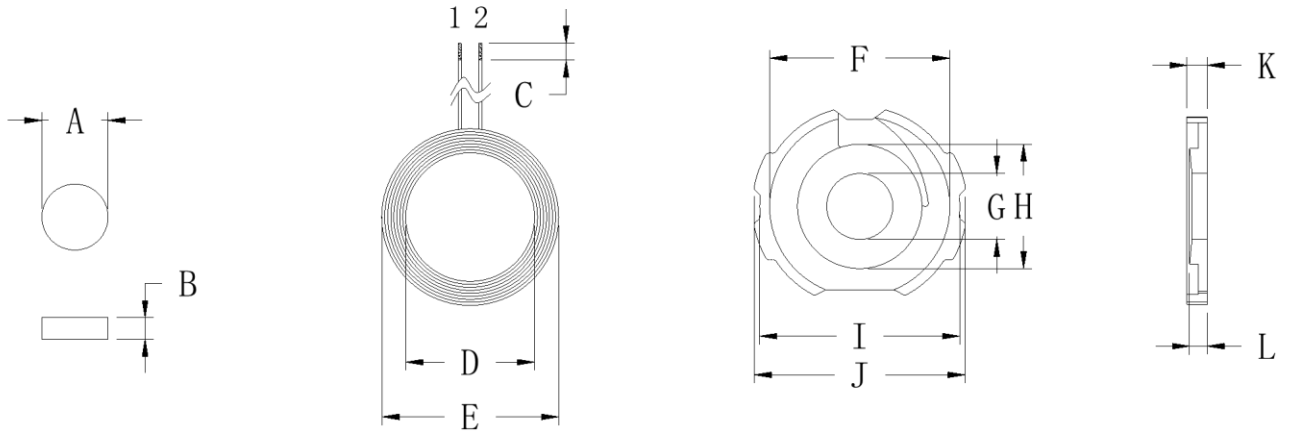

A	7.65 ± 0.05
B	2.5 ± 0.05
C	2 ± 1
D	14 ± 0.2
E	20.7 ± 0.3
F	21 ± 0.2
G	7.7 ± 0.05
H	13.5 ± 0.2
I	23.5 ± 0.2
J	25 ± 0.3
K	2.5 ± 0.1
L	2.25 ± 0.1 中柱高度
M	7 ± 1

四、 Product parameters:

Feet	Diameter of the line	Number of turns	Notes
1 - 2	0.08*24P	14	Hot Air Strand

五、 Technical requirements:

1. Fix the head and tail of thread to prevent loose and broken thread
2. According to customer's requirements, the length of wire shears, Tinning, tinning depth of $2 \pm 1\text{MM}$
3. In the magnetic point on the appropriate white glue, paste the coil, the process to ensure that t product surface clean and tidy
4. The soft disk used is with round hole, no damage
5. Install 7.65x2.5 mm magnet in the middle hole of the finished product and paste 14mm diameter round double-si adhesive on the back of the finished product

六、 Electrical parameters:

1. Inductance value, Q value:

$$\text{PIN PIN } 1 - 2 = 7.7 \sim 8.0\text{UH}$$

The above inductance values are based on chuanhua 1062A instrument, using 10KHZ/0.3 vrms as the standard or equivalent instrument. The Q value is based on chuanhua 1062A instrument and 100KHZ/0.3 vrms or equivalent instrument

七、Packaging:

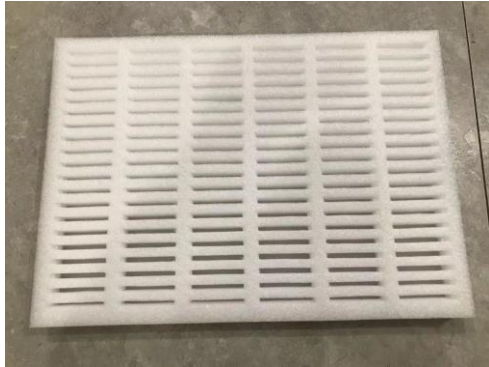

Figure 1:

Figure 1: Single-layer foam tray, 1 box packing 240 pcs



Figure 2:

Figure 2: Uniform Direction Line head up neatly into the disk



Figure 3:

Figure 3: put into the packing box, each box put 10 layers



Figure 4:

Figure 4: sealing the box with transparent glue

八、 Bill of materials:

NO	Name	Material	Suppliers	Notes
1	Hot Air Line	0.08*24P	Uyghur or equivalent	
2	Disk	G25 soft substrate	TX or equivalent	
3	Tin	Hightemperature environmental protection	Thond Island or equivalent	
4	White glue	BY882	Treasure month or equivalent	
5	Double-sided glue	513-14mm	Hung Fai or equivalent	
6	Strong magnetism	7.65*2.5(strength 3400±200GS)	Win-win or equal	