

# 零件承认书

## Part acknowledgement

供应商全称 Full name of supplier: 东莞捷瑞思科技有限公司  
Dongguan Jerice Technology Co., Ltd.  
供应商地址 Address of supplier: 东莞市大岭山朗湖路 96 号 (金雄达科技园 L 栋 3 楼)  
96 Long Wu Road, Tai Ling Shan, Dongguan (3F, building L, Kam Hung Tat Science and Technology Park)  
物料名称 Name of material: A11 线圈  
物料规格: Material specifications: A11 6.3uH\单股单层\20.5\*42\*0.08\*105P\10TS\磁片 Φ43\*1.0mm\材质 PC95\L=130mm\带背胶  
机种型号 Type and model: W371  
客户名称 Customer name: 络鑫电子  
客户料号 Customer data: E28-00048  
送样时间 Sample delivery time: 2023 年 10 月 07 日

备注 Notes:  新物料 New materials:  替代料 Alternative:

承认结果 Acknowledge the results	<input type="checkbox"/> 合格 Qualified <input type="checkbox"/> 不合格 Disqualified
	不合格原因 Reasons for non-conformance:
	不合格承认书及样品处理方式 Acceptance of non-conformance and sample handling: <input type="checkbox"/> 退回采购 Return purchase <input type="checkbox"/> 销毁处理 Disposal

供应商签章		
申请人 Applicant	品质 Quality	核准 Approval
陆琳	梁梅香	陆如圣
承认章 Recognition Stamp		
日期 Date: 2023.10.07		

承认签章 Recognize the signature				
申请人 Applicant	测试员 Tester	工程 Project	品质 Quality	核准 Approved
承认章 Recognition Stamp				
日期 Date:				

一、目录 Table of contents:

1. 封面 Cover	第 1-1 页
2. 目录 Table of contents	第 2-2 页
3. 产品图 Product drawings	第 3-3 页
4. 平面结构图 A plan	第 4-4 页
5. 产品参数 Product parameters	第 5-5 页
6. 电性参数 Electrical parameters	第 5-5 页
7. 材料清单	第 5-5 页
8. 包装 Packaging	第 6-6 页

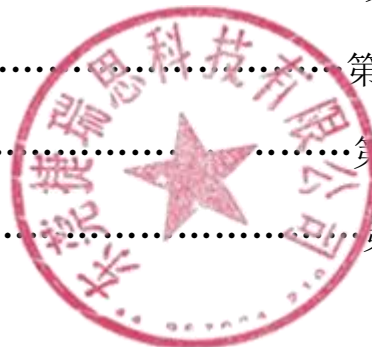

二、产品图面 Product drawing:



三、平面结构图 A plan: 单位:MM

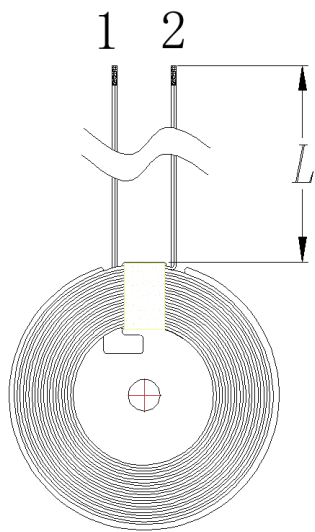
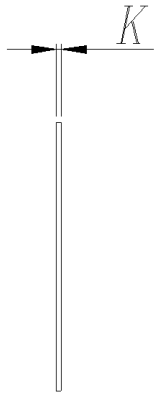
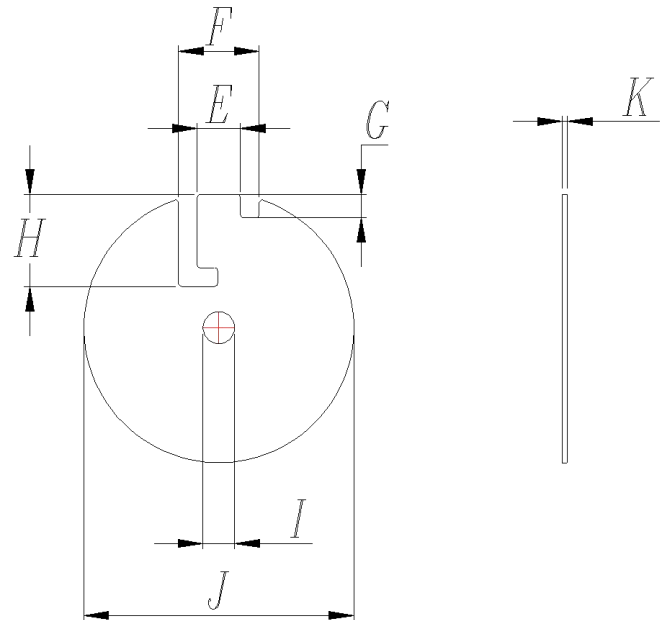
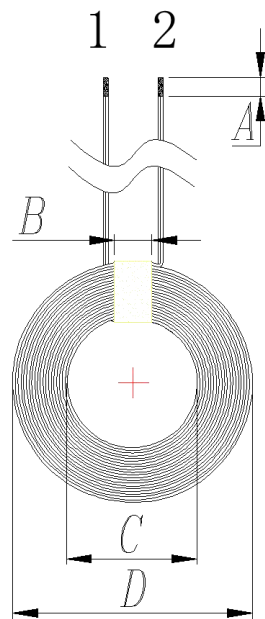

A	$0 \pm 1$
B	8
C	$20.5 \pm 0.5$
D	$40 \pm 1$
E	$7 \pm 0.5$
F	$12 \pm 0.5$
G	$4.0 \pm 0.5$
H	$14.5 \pm 0.5$
I	$5.2 \pm 0.2$
J	$43 \pm 0.5$
K	$1.0 \pm 0.1$
L	$130 \pm 2$

线圈: 10圈

四. 产品参数 Product parameters:					
圈数 Turns	线径 Wire Dia	绕线方式 疏/密 The way of winding is sparse/dense	绕线方向 Direction of winding	相交 是/否 Intersection yes/No	线圈 正/反贴 Positive/negative coil
10TS	0.08*105P 丝包线	密绕 Encircling	逆时针 Counterclockwise	是 Yes	反贴 Counter-post
所有材料要求合格 ROHS 标准 All materials required to meet ROHS standards					
五. 电气特性 Electrical characteristics					
温度: 25° ± 10C 湿度: 65° ± 10% Temperature: 25.0 ± 10c humidity: 65.0 ± 10%					
序号 NO	项目 Project	端子 Terminal	标准 Standards	测试条件 Test conditions	测试仪器 Test equipment
1	IND	1-2	线脚加磁片 PIN and disk: 电感: 6.3 uH ± 5% Q 值: ≥ 60 DCR 值: 0.05Ω ± 5%	1kHz/V	LCZ METER 1062
六. 材料清单 Bill of materials:					
序号 NO	材料名称 Name of material	品名描述 Description of product name	物料代码 Material Code	厂商代码 Vendor Code	
1	线材 Wire	0.08*105P 丝包线 Silk-clad wire	JR-RO-006	WH	
2	铁氧体 Ferrite	43*5.2*1.0 带孔双槽 L 型	G43-1.0-1008	TT	
3	双面胶 Double-sided glue	42*5.3*0.08H (带孔, 带手撕)	OT-42	HH	
4	金手指胶布 Gold finger tape	高温胶带 High temperature adhesive tape 8MN	GR-0008	GK	
5	胶水 Glue	白胶 White glue	BR-0001	BY	
6	锡条 Tin strips	环保无铅焊锡条 Environmentally friendly lead-free solder rod	无铅高温锡条	QD	



## 七、包装 Packaging:



图 1: 单层泡棉托盘 1 盒包装 270PCS



图 2: 统一方向线头朝上整齐排放入盘中,

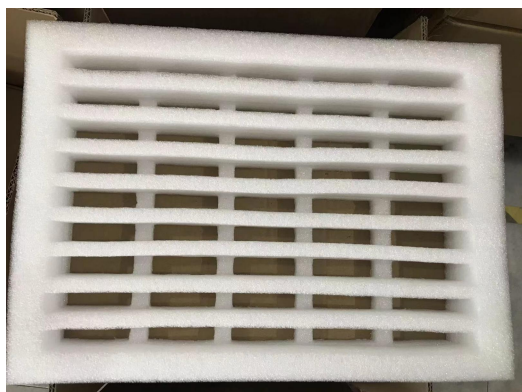

图 3: 放入包装箱, 每箱放置 5 层

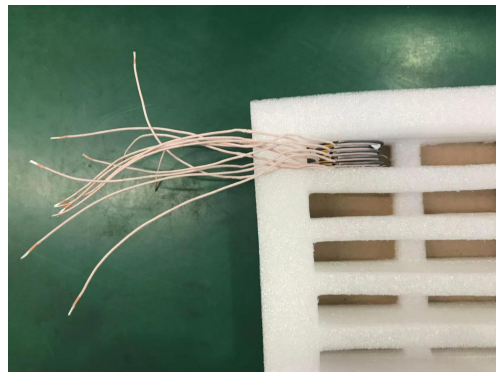

图 4: 封箱, 用透明胶封箱

江西络鑫科技有限公司			
进料标签			客户: JX
供应商	LX1265		ROHS
订单号			
料号	E28-00018		
规格	AII-43 1.0 3UH-130MM		
数量	108	单位	PCS
生产周期	2344		
生产批次	2023100704		
交货日期	2023/10/7		

图 5: 包装箱贴标签



图 6: 物料堆放, 整齐整洁, 标签往外方便寻找物料