

零件承认书

Zero acceptance

供应商全称/Full name of supplier: 东莞市泛亚电子有限公司
Dongguan FANYA Electronics Co., LTD

物料名称/Name of the material: 无线充线圈/Wireless charging coil

物料规格/Material gauge: 线圈\A11 6.3uH ±5% 单股单层 0.08*105P 10TS 磁片 φ43*1.0mm 开槽 L=20mm 带背胶 (101.0107)磁材PC95/ Coil \A11 6.3uH ±5% single strand single layer 0.08*105P 10TS disc φ43*1.0mm slotted L=20mm with adhesive (101.0107) magnetic material PC95

机种型号/Machine type number: A11 6.3uH ±5%

客户名称/Customer name: 络鑫电子 Luoxin Electronics

客户料号/Customer Part Number: E28-00019

送样时间Sample delivery time: 8月4日

备注remarks: 新物料New material 替代料 替代前型号 Substitute material replaces previous model

承认结果 Acknowledge the result	<input type="checkbox"/> 合格 qualified <input type="checkbox"/> 不合格 below standard
	不合格原因Reasons for nonconformity:
	不合格承认书及样品处理方式 Letter of nonconformity and sample handling: <input type="checkbox"/> 退回采购 Return purchase <input type="checkbox"/> 销毁处理Destruction disposal

供应商签章 Supplier signature	
申请人 proposer	品质quality 核准 authorizer
刘慧宜 Liu Huiyi	李圣龙 Li Shenglong 蔡纪雨 CAI jyu
承认章Recognition stamp	
日期date:	

承认签章 Acknowledgement seal				
申请人 proposer	测试员 test controler	工程 project	品质 quality	核准 authorizer
承认章Recognition stamp				
日期date:				

规格书/SPECIFICATION

产品型号: DESC	FYN00612023072903	版本 Rev: A.0	客户 CUST: 泛亚料号 Fine P/N: 客户料号 CUST P/N:	N006 FYN006003 E28-00019
---------------	--------------------------	----------------	--	---

一、尺寸 DIMENSION:(mm)

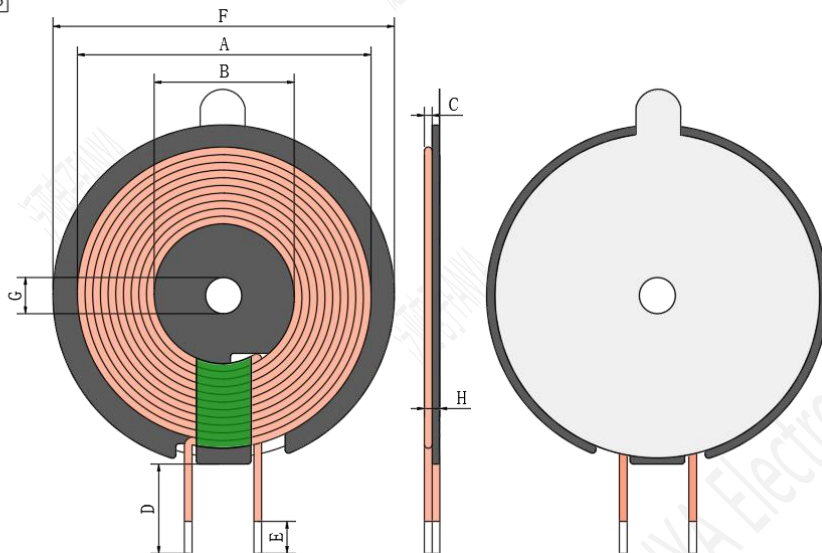
HF ROHS

A	40.5±1.0
B	20.5±0.5
C	1.2±0.2
D	20±1
E	2-4
F	43.5±0.5
G	5.3±0.5
H	2.7 Max (不含离型纸) (Excluding the paper thickness)

注/pour:

1. 线圈交叉出线/Coil cross line;
2. 线圈出线位置贴 8mm 宽绿色高温胶 /Attach 8mm wide green high-temperature adhesive to the outlet position of the coil;
3. 线圈反贴硬磁片, 硬磁片尺寸 ϕ 43.5*5.3*1.0mm, 开孔开双线槽/Coil back paste hard magnetic piece, hard magnetic piece size ϕ 43.5*5.3*1.0mm, hole open double line groove;
4. 磁片背面贴 ϕ 42*6*0.08mm 开孔带手撕普通双面背胶/On the back of the magnetic piece, stick ϕ 42*6*0.08mm hole with hand tear ordinary double-sided back tape.

二、原理图 SCHEMATIC DIAGRAM:

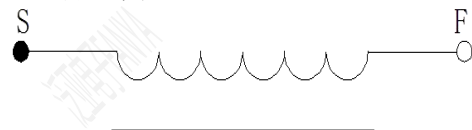

三、绕线参数 Winding Specification:

序号 NO.	端子 TERMINAL		线径 WIRE	圈数 Turns	绕线方向 Winding Direction
1	S	F	丝包线/silk-covered wire 0.078*105P	10Ts	CCW

四、电气特性 ELECTRICAL CHARACTERISTICS:

温度 TEMPERATURE:25±10°C, 湿度 RELATIVE HUMIDITY:65±20%

序号 NO.	项目 ITEM	端子 TERMINAL	标准 SPECIFICATION	测试条件 TEST FREQUENCY	测试仪器 TEST EQUIPMENTS
1	IND.	S-F	6.3uH ±5%	100KHz/1.0V	TH2810
2	DCR	S-F	43mΩ Max	100KHz/1.0V	TH2810

编制/日期 PREPARED BY/DATE 黄筱袁 IVY 2023/07/29	审核/日期 CHECKED BY/DATE 蔡纪雨 CAI jyu 2023/07/29
--	---

SPECIFICATION

產品型號: DESC	FYN00612023072903	版本 Rev: A.0	客戶 CUST: 泛亚料号 Fine P/N: 客户料号 CUST P/N:	N006 FYN006003 E28-00019
---------------	--------------------------	----------------	--	---

五、包装 PACKING:

5.1 包装图片 Packing pictures:

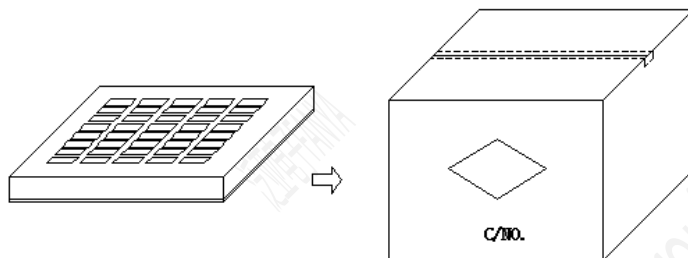

5.2 包装数量及规格 Packing Quantity:

项目 Item	数量 Quantity	材料规格 Material
盘 Box	200 Pcs	370*265*55mm
箱 Big Carton	1000 Pcs	420*270*310mm

5.3 包装以现有包装盘为参照标准，以实际出货包装为准,如有特需要求可以定制。

The packaging shall be based on the existing packing plate and the actual delivery package shall prevail. If there is any requirement, we can customize it.

六、材料清单 Material list:

序号 number	材料名称 Material name	品名描述 Description	制造商 Manufacturer
1	silk-covered wire	0.08*105P	
2	无铅锡条/No lead tin strip	无铅锡条/No lead tin strip	
3	磁片/magnetic sheet	硬磁片尺寸 ϕ 43.5*5.3*1.0mm, 开孔开双线槽/ Hard magnetic sheet size ϕ 43.5*5.3*1.0mm, open hole open double line groove	
4	绿色高温胶/ Green high temperature glue	8mm 宽的高温胶/ 8mm wide hot gel	
5	普通背胶/ Ordinary back glue	ϕ 42*6*0.08mm 带手撕位普通背胶/ ϕ 42*6*0.08mm With the hand to tear the ordinary back glue	

擬制/日期 PREPARED BY/DATE	審核/日期 CHECKED BY/DATE
黄筱袁 IVY 2023/07/29	蔡纪雨 CAI jyu 2023/07/29