

零件承认书

Part acknowledgement

供应商全称 Full name of supplier: 东莞捷瑞思科技有限公司

Dongguan Jerice Technology Co., Ltd.

供应商地址 Address of supplier: 东莞市大岭山朗湖路 96 号（金雄达科技园 L 栋 3 楼）

96 Long Wu Road, Tai Ling Shan, Dongguan (3F, building L, Kam Hung Tat Science and Technology Park)

物料名称 Name of material: : 手表线圈 Watch coil

物料规格: Material specifications: 软磁 25*2.6MM 0.08*28P 7.7UH-8.0UH 单股双层 带 N52 磁铁 磁力 3400GS±200GS 带背胶 L=7MM

机种型号 Type and model: _____

客户名称 Customer name: 络鑫电子

客户料号 Customer data: E28-00011

送样时间 Sample delivery time: 2023 年 8 月 2 日

备注 Notes: 新物料 New materials: 代料 Alternative:

承认结果 Acknowledge the results	<input type="checkbox"/> 合格 Qualified <input type="checkbox"/> 不合格 Disqualified
	不合格原因 Reasons for non-conformance:
	不合格承认书及样品处理方式 Acceptance of non-conformance and sample handling: <input type="checkbox"/> 退回采购 Return purchase <input type="checkbox"/> 销毁处理 Disposal

供应商签章 Signature of supplier		
申请人 Applicant	品质 Quality	核准 Approved
陆琳	梁梅香	陆如圣
承认章 Recognition Stamp		
日期 Date: 2023.8.2		

承认签章 Recognize the signature				
申请人 Applicant	测试员 Tester	工程 Project	品质 Quality	核准 Approved
承认章 Recognition Stamp				
日期 Date:				

一、目录： Table of contents

1. 封面 Cover	第 1-1 页
2. 目录 Table of contents	第 2-2 页
3. 产品图 Product drawings	第 3-3 页
4. 尺寸图 Size Map	第 4-4 页
5. 产品参数 Product parameters	第 5-5 页
6. 技术要求 Technical requirements	第 5-5 页
7. 电性参数 Electrical parameters	第 5-5 页
8. 包装 Packaging	第 6-6 页
9. 材料清单 Bill of materials	第 7-7 页

二、产品图面 Product drawing:



三、平面结构图 A plan: 单位:MM

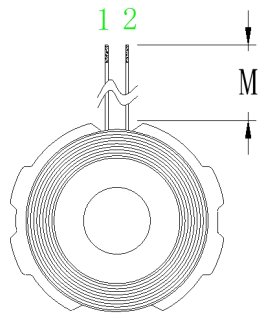
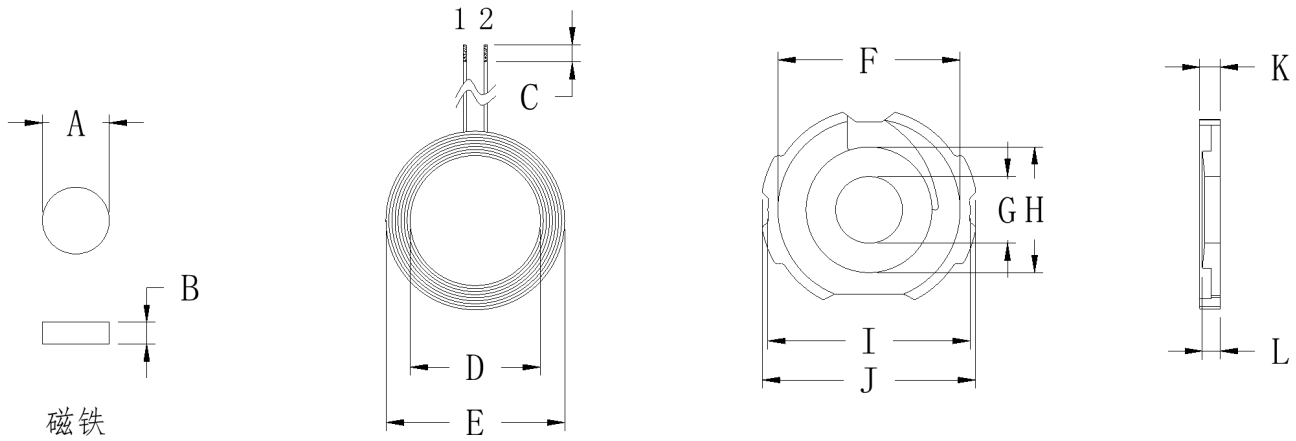

A	7.65 ± 0.05
B	2.5 ± 0.05
C	2 ± 1
D	14 ± 0.2
E	20.7 ± 0.3
F	21 ± 0.2
G	7.7 ± 0.05
H	13.5 ± 0.2
I	23.5 ± 0.2
J	25 ± 0.3
K	2.5 ± 0.1
L	2.25 ± 0.1 中柱高度
M	7 ± 1

四、产品参数 Product parameters:

脚位 Feet	线径 Diameter of the line	圈数 Number of turns	备注 Notes
1 - 2	0.08*28P	14	热风绞合线 Hot Air Strand

五、技术要求 Technical requirements:

1. 固定好线头线尾，防止线松断线等现象

Fix the head and tail of thread to prevent loose and broken thread

2. 按客户要求把过长的线头剪，镀上锡，镀锡深度统一为 $2 \pm 1\text{MM}$

According to customer's requirements, the length of wire shears, Tinning, tinning depth of $2 \pm 1\text{MM}$

3. 在磁片上点上适当的白胶，贴上线圈，过程中要保证产品表面干净整洁

In the magnetic point on the appropriate white glue, paste the coil, the process to ensure that product surface clean and tidy

4. 所用软磁片为带圆孔，无破损

The soft disk used is with round hole, no damage

5. 附加工序（按客户要求）：于成品中间圆孔装上 $7.65 \times 2.5\text{mm}$ 的磁铁并在成品背后加贴直径 14mm 的圆双面胶，后包装

Install $7.65 \times 2.5\text{ mm}$ magnet in the middle hole of the finished product and paste 14mm diameter round double-side adhesive on the back of the finished product

六、电性参数 Electrical parameters:

1. 电感值，Q 值 Inductance value, Q value:

$$\text{PIN PIN } 1 - 2 = 7.7 \sim 8.0\text{UH}$$

以上电感值以铨华 1062A 仪器，以 $10\text{KHZ}/0.3\text{Vrms}$ 为标准或等同仪器。

Q 值以铨华 1062A 仪器，以 $100\text{KHZ}/0.3\text{Vrms}$ 为标准或等同仪器

The above inductance values are based on chuanhua 1062A instrument, using $10\text{KHZ}/0.3\text{ vrms}$ as the standard or equivalent instrument. The Q value is based on chuanhua 1062A instrument and $100\text{KHZ}/0.3\text{ vrms}$ or equivalent instrument

七、包装 Packaging:



图 1: 单层泡棉托盘, 1 盒包装 240PCS

Figure 1: Single-layer foam tray, 1 box packing 240 pcs

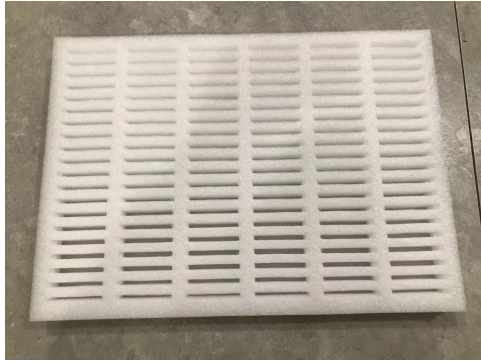

图 2: 统一方向线头朝上整齐排放入盘中

Figure 2: Uniform Direction Line head up neatly into the disk



图 3: 放入包装箱, 每箱放置 10 层

Figure 3: put into the packing box, each box put 10 layers



图 4: 封箱, 用透明胶封箱

Figure 4: sealing the box with transparent glue

江西络鑫科技有限公司			
进料标签			客户: JX
供应商	LX1265		ROHS
订单号			
料号	E8-00011		
规格	RC-G25-7.8UH-28P-8MM		
数量	2400	单位	PCS
生产周期	2335		
生产批次	20230802001		
交货日期	2023/8/2		



图 5: 包装箱贴标签

Figure 5: Packaging label

图 6: 物料堆放, 整齐, 标签往外方便寻找物料

Figure 6: materials stacked, neat, labels to facilitate the search for materials

八、材料清单 Bill of materials:

序号 NO	名称 Name	材质 Material	供应商 Suppliers	备注 Notes
1	热风线 Hot Air Line	0.08*28P	维汉或等同 Uyghur or equivalent	
2	磁片 Disk	G25 软基材 G25 soft substrate	天通或等同 TX or equivalent	
3	锡 Tin	高温环保 Hightemperature environmental protection	千岛或等同 Thond Island or equivalent	
4	白胶 White glue	BY882	宝月或等同 Treasure month or equivalent	
5	双面胶 Double-sided glue	513-14mm	鸿辉或等同 Hung Fai or equivalent	
6	强磁 Strong magnetism	7.65*2.5(强度 3400± 200GS)	联胜或等同 Win-win or equal	