

# Zero acceptance

Dongguan FANYA Electronics Co., LTD

Full name of supplier: \_\_\_\_\_

Wireless charging coil

Name of the material: \_\_\_\_\_

Material gauge: Wireless charging coil A11 coil with porcelain 6.3UH±10%,  
line length 60CMM, with high temperature adhesive

Machine type number: \_\_\_\_\_

Customer name: Luoxin Electronics

Customer Part Number: E28-00013

Sample delivery time: 7月25日

remarks:  New material  Substitute material replaces previous model

Acknowledge the result	<input type="checkbox"/> qualified <input type="checkbox"/> below standard	
	Reasons for nonconformity:	
	Letter of nonconformity and sample handling:	<input type="checkbox"/> Return purchase <input type="checkbox"/> Destruction disposal

Suppliersignature		
proposer	quality	authorizer
LiuHuiyi	Li Shenglong	CAIjyu
Recognition stamp		
date:		

Acknowledgement seal				
proposer	test controler	project	quality	authorizer
Recognition stamp				
date:				

1. Certificate in triplicate (purchase quality engineering) 2. Sample each certificate 3-5pcs 3. Sign and seal

### Version Change History

Rev.	Before Change	After Change	Change Date	Approved By
A.0	新发行	----	2023/07/25	Ding Baoyuan

# SPECIFICATION

DESC	<b>FYN00612023072502</b>	Rev: A.0	CUST:	<b>N006</b>
			Fine P/N:	
			CUST P/N:	<b>E28-00013</b>

一、 DIMENSION:(mm)

HF ROHS

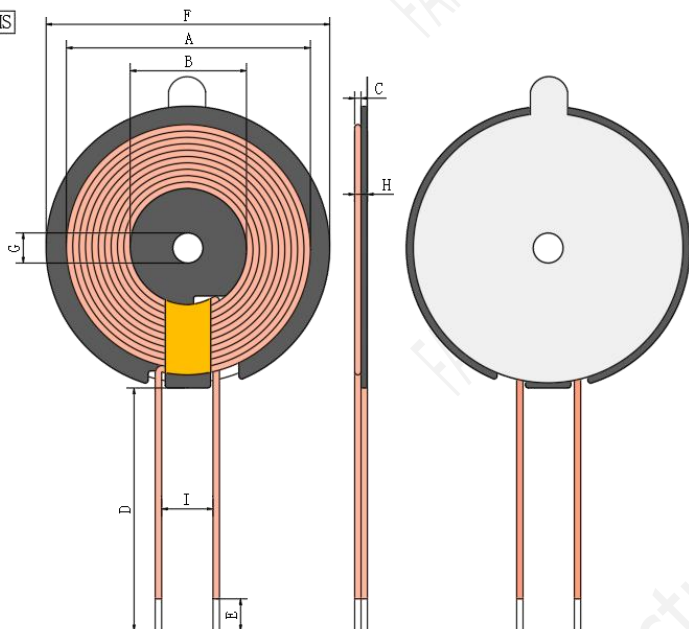

A	40.5±1.5
B	20.5±0.5
C	1.25Max
D	60±2
E	3±1
F	43.5±0.5
G	5.3±0.5
H	2.5 Max (No release paper)
I	10±2

二、 SCHEMATIC DIAGRAM:

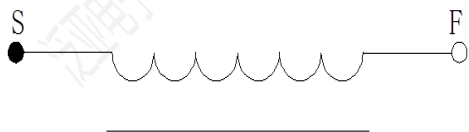

pour:

1. The coil is crossed out
2. 8mm wide high temperature glue is attached to the outlet position of the coil;
3. The coil is backmounted with hard magnetic sheet, the size of hard magnetic sheet is  $\phi$  43.5\*5.3\*1.0mm, and the hole is opened with L double wire groove;
4. The back of the magnet is pasted with  $\phi$  42\*6\*0.08mm open hole and ordinary double-sided back glue with hand tear position.

三、 Winding Specification:

NO.	TERMINAL		WIRE	Turns	Winding Direction
1	S	F	silk-covered wire 0.08*105P	10Ts	CCW

四、 ELECTRICAL CHARACTERISTICS:

TEMPERATURE:25±10°C, RELATIVE HUMIDITY:65±20%

NO.	ITEM	TERMINAL	SPECIFICATION	TEST FREQUENCY	TEST EQUIPMENTS
1	IND.	S-F	6.3uH ±10%	100KHz/1.0V	TH2810
2	DCR	S-F	55mΩ Max		TH2810

PREPARED BY/DATE	CHECKED BY/DATE
IVY 2023/09/26	CAI jyu 2023/09/26

## SPECIFICATION

DESC	<b>FYN00612023072502</b>	Rev: A.0	CUST:	<b>N006</b>
			Fine P/N:	
			CUST P/N:	<b>E28-00013</b>

五、PACKING:

5.1 Packing pictures:

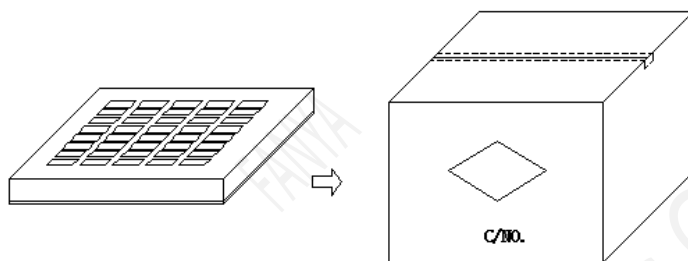

5.2 Packing Quantity:

Item	Quantity	Material
Box	200 Pcs	370*265*55mm
Big Carton	1000 Pcs	420*270*310mm

5.3 The packaging shall be based on the existing packing plate and the actual delivery package shall prevail. If there is any requirement, we can customize it.

六、Material list:

number	Material name	Description	Manufacturer
1	silk-covered wire	silk-covered wire 0.08*105P	
2	No lead tin strip	No lead tin strip	
3	magnetic sheet	Hard magnetic sheet size $\phi$ 43.5*5.3*1.0mm, open hole open L double line slot	
4	high-temperature adhesive	8mm wide high temperature glue	
5	Common adhesive	$\phi$ 42*6*0.08mm Open the middle hole with the hand to tear the ordinary back glue	

PREPARED BY/DATE	CHECKED BY/DATE
IVY2023/09/26	CAI jyu 2023/09/26