

FCC RADIO TEST REPORT

FCC ID: 2BBE3-A6

Sample : Car wireless charging bracket

Trade Mark : N/A

Main Model : A6-1

Additional Model : A6, A6-2

Report No. : UNIA23052419ER-61

Prepared for

Shenzhen Baolifeng Electronic Technology Co., Ltd.

Room C1111, Block C, niulanqian building, Minzhi Avenue, Longhua New
District, Shenzhen, China

Prepared by

Shenzhen United Testing Technology Co., Ltd.

D101, No. 107, Kaicheng High-Tech Park, Taoyuan Community,
Dalang Sub-District, Longhua District, Shenzhen, Guangdong, China/518109

TEST RESULT CERTIFICATION

Applicant : Shenzhen Baolifeng Electronic Technology Co., Ltd.
Address : Room C1111, Block C, niulanqian building, Minzhi Avenue,
Longhua New District, Shenzhen, China
Manufacturer : Shenzhen Baolifeng Electronic Technology Co., Ltd.
Address : Room C1111, Block C, niulanqian building, Minzhi Avenue,
Longhua New District, Shenzhen, China

Product description

Product..... : Car wireless charging bracket
Trade Mark : N/A
Model Name : A6-1, A6, A6-2

Test Methods..... : FCC Rules and Regulations Part 15 Subpart C Section 15.209
ANSI C63.10: 2013

This device described above has been tested by Shenzhen ZKT Technology Co., Ltd., and the test results show that the equipment under test (EUT) is in compliance with the FCC requirements. And it is applicable only to the tested sample identified in the report. This report shall not be reproduced except in full, without the written approval of UNI, this document may be altered or revised by Shenzhen United Testing Technology Co., Ltd., personnel only, and shall be noted in the revision of the document.

Date of Test :
Date (s) of performance of tests : May 24, 2023 ~ May 30, 2023
Date of Issue..... : May 30, 2023
Test Result..... : Pass

Prepared by:



Jason Ye/Supervisor

Reviewer:

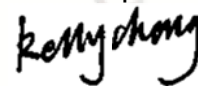

Kelly Cheng/Supervisor

Approved & Authorized Signer:



Liuze/Manager

| Table of Contents | Pages |
|-----------------------------------|--------------|
| 1 TEST SUMMARY | 4 |
| 1.4 ENVIRONMENTAL CONDITIONS | 6 |
| 2 GENERAL INFORMATION | 7 |
| 2.1 GENERAL DESCRIPTION OF EUT | 7 |
| 2.2 CARRIER FREQUENCY OF CHANNELS | 8 |
| 2.3 TEST MODE | 8 |
| 3 CONDUCTED EMISSION | 10 |
| 3.1 TEST LIMIT | 10 |
| 3.2 TEST SETUP | 10 |
| 3.3 TEST PROCEDURE | 11 |
| 3.4 TEST RESULT | 11 |
| 4 RADIATED EMISSION | 14 |
| 4.1 TEST LIMIT | 14 |
| 4.2 TEST SETUP | 16 |
| 4.3 TEST PROCEDURE | 17 |
| 4.4 TEST RESULT | 17 |
| 5 ANTENNA REQUIREMENT | 20 |
| 6 PHOTO OF TEST | 21 |
| 6.1 RADIATED EMISSION | 21 |
| 6.2 CONDUCTED EMISSION | 22 |

1 TEST SUMMARY

1.1 TEST PROCEDURES AND RESULTS

| Item | FCC Rules | Description Of Test | Result |
|------|-----------------|---------------------|--------|
| 1 | FCC Part 15.207 | Conducted Emission | Pass |
| 2 | FCC Part 15.209 | Radiated Emission | Pass |
| 3 | FCC Part 15.203 | Antenna Requirement | Pass |

1.2 TEST FACILITY

Test Firm : Shenzhen ZKT Technology Co., Ltd.
Address : 1/F, No. 101, Building B, No. 6, Tangwei Community Industrial Avenue,
Fuhai Street, Bao'an District, Shenzhen, China

The testing quality ability of our laboratory meet with "Quality Law of People's Republic of China" Clause 19. The testing quality system of our laboratory meets with ISO/IEC-17025 requirements. This approval result is accepted by MRA of APLAC.

Our test facility is recognized, certified, or accredited by the following organizations:

Designation Number: CN1299

The EMC Laboratory has been accredited by A2LA, and in compliance with ISO/IEC 17025:2017 General Requirements for testing Laboratories.

FCC Registration Number: 692225

The EMC Laboratory has been registered and fully described in a report filed with the (FCC) Federal Communications commission.

IC Registration Number: 27033

The EMC Laboratory has been registered and fully described in a report filed with the (IC) Industry Canada.

1.3 MEASUREMENT UNCERTAINTY

The reported uncertainty of measurement $y \pm U$, where expanded uncertainty U is based on a standard uncertainty multiplied by a coverage factor of $k=2$, providing a level of confidence of approximately 95 %.

A. Conducted Measurement:

| Test Site | Method | Measurement Frequency Range | U, (dB) | NOTE |
|-----------|--------|-----------------------------|---------|------|
| UNI | ANSI | 9KHz ~ 150KHz | 2.96 | -- |
| | | 150KHz ~ 30MHz | 2.44 | -- |

B. Radiated Measurement:

| Test Site | Method | Measurement Frequency Range | U, (dB) | NOTE |
|-----------|--------|-----------------------------|---------|------|
| UNI | ANSI | 9KHz ~ 30MHz | 2.50 | -- |
| | | 30MHz ~ 1000MHz | 4.80 | -- |
| | | 1000MHz ~ 6000MHz | 4.13 | -- |

1.4 ENVIRONMENTAL CONDITIONS

During the measurement the environmental conditions were within the listed ranges:

| | |
|--------------------|--------------|
| Temperature: | 15~35 °C |
| Relative Humidity: | 30~60 % |
| Air Pressure: | 950~1050 hPa |

2 GENERAL INFORMATION

2.1 GENERAL DESCRIPTION OF EUT

| | |
|----------------------|--|
| Product: | Car wireless charging bracket |
| Trade Mark: | N/A |
| Main Model: | A6-1 |
| Additional Model: | A6, A6-2 |
| Model Difference: | All model's the function, software and electric circuit are the same, only with a product color and model named different. Test sample model: A6-1. |
| FCC ID: | 2BBE3-A6 |
| Operation Frequency: | 110-205kHz |
| Max Field Strength | 97.61dBuV/m |
| Number of Channels: | 1CH |
| Modulation Type: | ASK |
| Antenna Type: | Coil Antenna |
| Antenna Gain: | 0dBi |
| Battery: | DC 3.7V, 200mAh (Note: For motor power only.) |
| Adapter: | N/A |
| Power Source: | DC 5V/9V from adapter |

2.2 CARRIER FREQUENCY OF CHANNELS

| Channel List | |
|--------------|-----------------|
| Channel | Frequency (KHz) |
| 01 | 125.0 |

2.3 TEST MODE

| NO. | TEST MODE DESCRIPTION |
|-----|--|
| 1 | Wireless charging Mode(Full load)(Connect to adapter) |
| 2 | Wireless charging Mode(Half load) (Connect to adapter) |
| 3 | Wireless charging Mode(Null load) (Connect to adapter) |

Note: The mode 1 was the worst case and only the data of the worst case record in this report.

2.4 TEST SETUP

Operation of EUT during testing:



2.5 DESCRIPTION TEST PERIPHERAL AND EUT PERIPHERAL

The EUT has been tested as an independent unit together with other necessary accessories or support units. The following support units or accessories were used to form a representative test configuration during the tests.

| Item | Equipment | Mfr/Brand | Model/Type No. | Note |
|------|-------------------------------|-----------|----------------|------|
| E-1 | Car wireless charging bracket | N/A | A6-1 | EUT |
| E-2 | Adapter | XIAOMI | MDY-08-EF | AE |
| E-3 | iPhone | Apple | iPhone 13 | AE |

Note:

1. The support equipment was authorized by Declaration of Confirmation.
2. All the above equipment/cables were placed in worse case positions to maximize emission signals during emission test.

2.6 MEASUREMENT INSTRUMENTS LIST

| Item | Equipment | Manufacturer | Model No. | Serial No. | Calibrated until |
|----------------------------------|-------------------------------------|---------------|----------------|---------------|------------------|
| Conduction Emissions Measurement | | | | | |
| 1 | Conducted Emission Test Software | EZ-EMC | Ver.CCS-3A1-CE | N/A | N/A |
| 2 | AMN | Schwarzbeck | NNLK8121 | 8121370 | 2023.09.22 |
| 3 | AAN | TESEQ | T8-Cat6 | 38888 | 2023.09.22 |
| 4 | Pulse Limiter | CYBRTEK | EM5010 | E115010056 | 2023.05.30 |
| 5 | EMI Test Receiver | Rohde&Schwarz | ESCI | 101210 | 2023.09.22 |
| Radiated Emissions Measurement | | | | | |
| 1 | Radiated Emission Test Software | EZ-EMC | Ver.CCS-03A1 | N/A | N/A |
| 2 | Horn Antenna | Sunol | DRH-118 | A101415 | 2023.09.22 |
| 3 | Broadband Hybrid Antenna | Sunol | JB1 | A090215 | 2024.02.26 |
| 4 | PREAMP | HP | 8449B | 3008A00160 | 2023.09.22 |
| 5 | PREAMP | HP | 8447D | 2944A07999 | 2023.05.30 |
| 6 | EMI TEST RECEIVER | Rohde&Schwarz | ESR3 | 101891 | 2023.09.22 |
| 7 | VECTOR Signal Generator | Rohde&Schwarz | SMU200A | 101521 | 2023.09.22 |
| 8 | Signal Generator | Agilent | E4421B | MY4335105 | 2023.09.22 |
| 9 | MXA Signal Analyzer | Agilent | N9020A | MY50510140 | 2023.09.22 |
| 10 | MXA Signal Analyzer | Keysight | N9020A | MY51110104 | 2023.09.22 |
| 11 | RF Power sensor | DARE | RPR3006W | 15I00041SNO88 | 2023.05.30 |
| 12 | RF Power sensor | DARE | RPR3006W | 15I00041SNO89 | 2023.05.30 |
| 13 | RF power divider | Anritsu | K241B | 992289 | 2023.09.22 |
| 14 | Wideband radio communication tester | Rohde&Schwarz | CMW500 | 154987 | 2023.09.22 |
| 15 | Active Loop Antenna | Com-Power | AL-130R | 10160009 | 2023.05.30 |
| 16 | Broadband Hybrid Antennas | Schwarzbeck | VULB9163 | VULB9163#958 | 2023.09.22 |
| 17 | Horn Antenna | Schwarzbeck | BBHA9120D | 9120D-1680 | 2023.05.30 |
| 18 | Horn Antenna | A-INFOMW | LB-180400-KF | J211060660 | 2023.09.22 |
| 19 | Microwave Broadband Preamplifier | Schwarzbeck | BBV 9721 | 100472 | 2023.09.22 |
| 20 | Signal Generator | Agilent | N5183A | MY47420153 | 2023.09.22 |
| 21 | Spectrum Analyzer | Rohde&Schwarz | FSP 40 | 100501 | 2023.09.22 |
| 22 | Power Meter | KEYSIGHT | N1911A | MY50520168 | 2023.09.22 |
| 23 | Frequency Meter | VICTOR | VC2000 | 997406086 | 2023.09.22 |
| 24 | DC Power Source | HYELEC | HY5020E | 055161818 | 2023.09.22 |

3 CONDUCTED EMISSION

3.1 TEST LIMIT

For unintentional device, according to § 15.107(a) Line Conducted Emission Limits is as following

| Frequency (MHz) | Maximum RF Line Voltage (dB V) | | | |
|-----------------|--------------------------------|------|---------|--------|
| | CLASS A | | CLASS B | |
| | Q.P. | Ave. | Q.P. | Ave. |
| 0.15~0.50 | 79 | 66 | 66~56* | 56~46* |
| 0.50~5.00 | 73 | 60 | 56 | 46 |
| 5.00~30.0 | 73 | 60 | 60 | 50 |

* Decreasing linearly with the logarithm of the frequency.

For intentional device, according to §15.207(a) Line Conducted Emission Limit is same as above table.

3.2 TEST SETUP

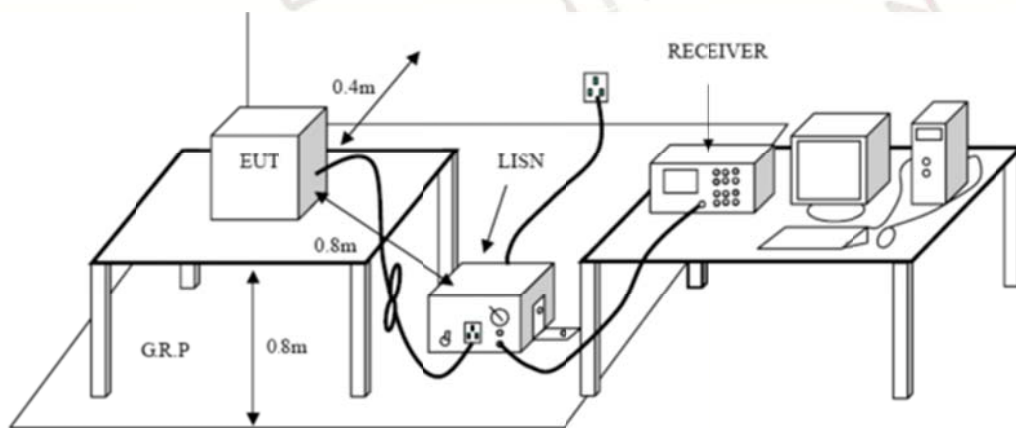

3.3 TEST PROCEDURE

1. The equipment was set up as per the test configuration to simulate typical actual usage per the user's manual. The EUT is placed on a wooden table with a height of 0.8 meters is used and is placed on the ground plane as per ANSI C63.10.
2. Support equipment, if needed, was placed as per ANSI C63.10.
3. All I/O cables were positioned to simulate typical actual usage as per ANSI C63.10.
4. If a EUT received DC power from the USB Port of Notebook PC, the PC's adapter received AC120V/60Hz power through a Line Impedance Stabilization Network (LISN) which supplied power source and was grounded to the ground plane.
5. All support equipments received AC power from a second LISN, if any.
6. The EUT test program was started. Emissions were measured on each current carrying line of the EUT using a spectrum Analyzer / Receiver connected to the LISN powering the EUT. The LISN has two monitoring points: Line 1 (Hot Side) and Line 2 (Neutral Side). Two scans were taken: one with Line 1 connected to Analyzer / Receiver and Line 2 connected to a 50 ohm load; the second scan had Line 1 connected to a 50 ohm load and Line 2 connected to the Analyzer / Receiver.
7. Analyzer / Receiver scanned from 150 KHz to 30MHz for emissions in each of the test modes.

3.4 TEST RESULT

PASS

Remark: EUT was tested at AC 120V and 240V, only the worst result of AC 120V was reported.

| | | | |
|---------------|---------------------------------|--------------------|---------|
| Temperature: | 24°C | Relative Humidity: | 48% |
| Test Date: | May 26, 2023 | Pressure: | 1010hPa |
| Test Voltage: | AC 120V, 60Hz | Phase: | Line |
| Test Mode: | Transmitting mode 1 of 125.0kHz | | |

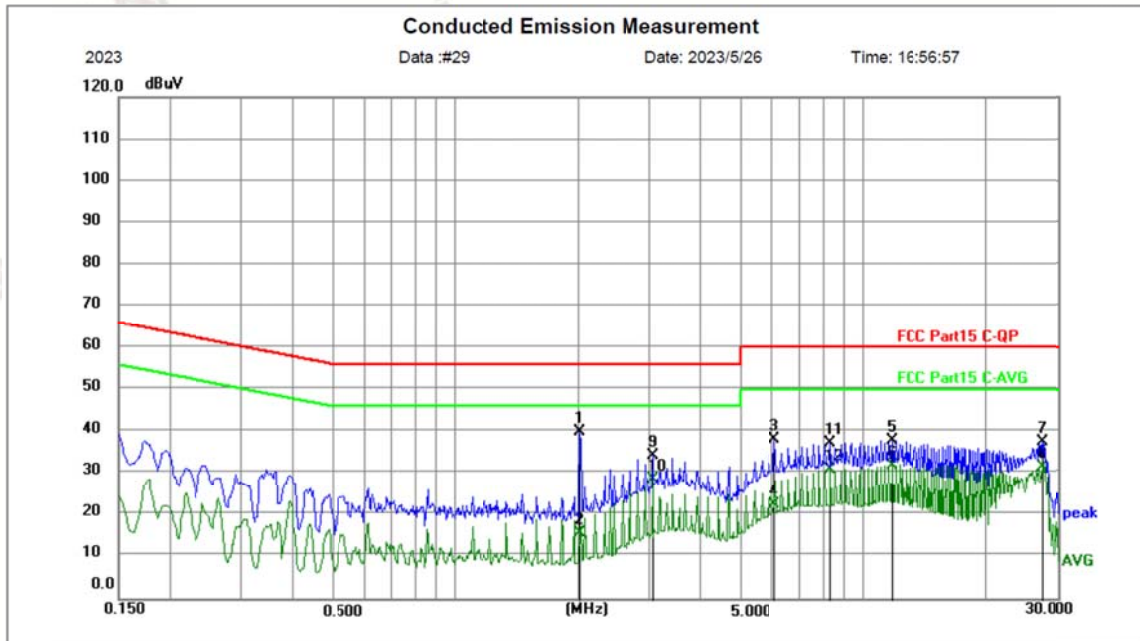

| No. | Frequency (MHz) | Reading (dBuV) | Factor (dB) | Level (dBuV) | Limit (dBuV) | Margin (dB) | Detector | P/F | Remark |
|-----|-----------------|----------------|-------------|--------------|--------------|-------------|----------|-----|--------|
| 1 * | 2.0219 | 30.44 | 9.72 | 40.16 | 56.00 | -15.84 | peak | P | |
| 2 | 2.0219 | 6.03 | 9.72 | 15.75 | 46.00 | -30.25 | AVG | P | |
| 3 | 6.0674 | 28.86 | 9.53 | 38.39 | 60.00 | -21.61 | peak | P | |
| 4 | 6.0674 | 13.09 | 9.53 | 22.62 | 50.00 | -27.38 | AVG | P | |
| 5 | 11.7104 | 28.22 | 9.77 | 37.99 | 60.00 | -22.01 | peak | P | |
| 6 | 11.7104 | 22.13 | 9.77 | 31.90 | 50.00 | -18.10 | AVG | P | |
| 7 | 27.2895 | 27.83 | 9.68 | 37.51 | 60.00 | -22.49 | peak | P | |
| 8 | 27.2895 | 22.08 | 9.68 | 31.76 | 50.00 | -18.24 | AVG | P | |
| 9 | 3.0525 | 24.63 | 9.62 | 34.25 | 56.00 | -21.75 | peak | P | |
| 10 | 3.0525 | 19.05 | 9.62 | 28.67 | 46.00 | -17.33 | AVG | P | |
| 11 | 8.2904 | 27.57 | 9.63 | 37.20 | 60.00 | -22.80 | peak | P | |
| 12 | 8.2904 | 21.54 | 9.63 | 31.17 | 50.00 | -18.83 | AVG | P | |

Remark:1. Factor = Insertion Loss + Cable Loss, Result = Reading + Factor, Margin = Result – Limit.

2. Phone and Headset and Watch charging together was the worst case and only the data of the worst case record in this report.

| | | | |
|---------------|---------------------------------|--------------------|---------|
| Temperature: | 24°C | Relative Humidity: | 48% |
| Test Date: | May 26, 2023 | Pressure: | 1010hPa |
| Test Voltage: | AC 120V, 60Hz | Phase: | Neutral |
| Test Mode: | Transmitting mode 1 of 125.0kHz | | |

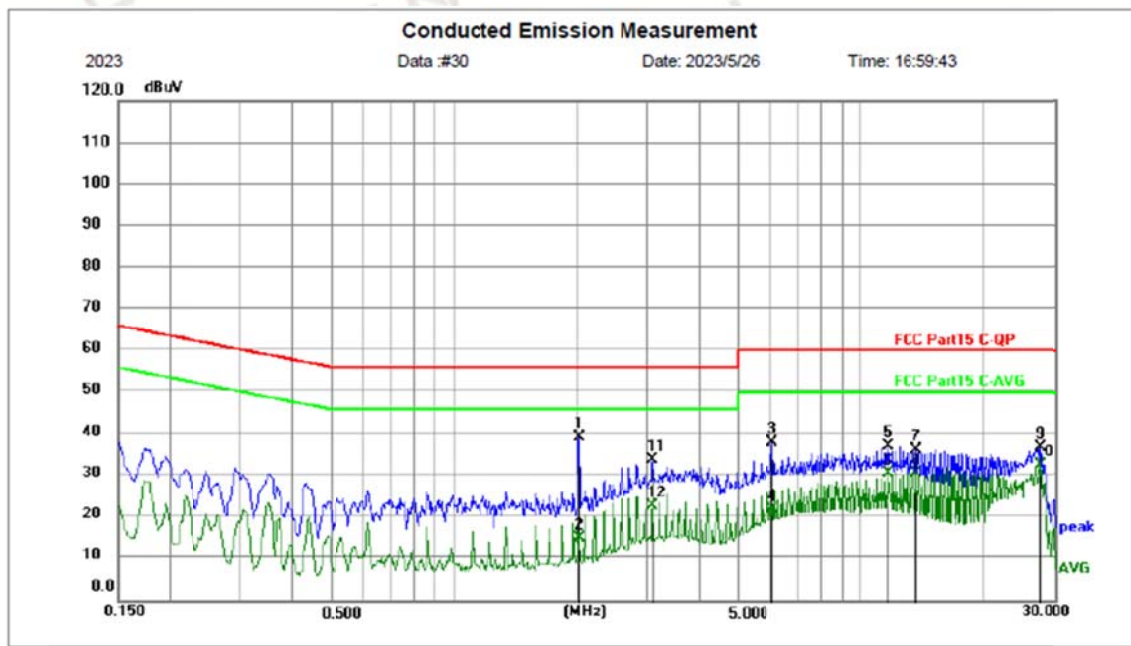

| No. | Frequency (MHz) | Reading (dBuV) | Factor (dB) | Level (dBuV) | Limit (dBuV) | Margin (dB) | Detector | P/F | Remark |
|-----|-----------------|----------------|-------------|--------------|--------------|-------------|----------|-----|--------|
| 1 * | 2.0264 | 29.65 | 9.72 | 39.37 | 56.00 | -16.63 | peak | P | |
| 2 | 2.0264 | 5.55 | 9.72 | 15.27 | 46.00 | -30.73 | AVG | P | |
| 3 | 6.0720 | 28.67 | 9.53 | 38.20 | 60.00 | -21.80 | peak | P | |
| 4 | 6.0720 | 12.59 | 9.53 | 22.12 | 50.00 | -27.88 | AVG | P | |
| 5 | 11.6790 | 27.56 | 9.76 | 37.32 | 60.00 | -22.68 | peak | P | |
| 6 | 11.6790 | 21.14 | 9.76 | 30.90 | 50.00 | -19.10 | AVG | P | |
| 7 | 13.6455 | 26.71 | 9.77 | 36.48 | 60.00 | -23.52 | peak | P | |
| 8 | 13.6455 | 21.05 | 9.77 | 30.82 | 50.00 | -19.18 | AVG | P | |
| 9 | 27.5369 | 27.28 | 9.69 | 36.97 | 60.00 | -23.03 | peak | P | |
| 10 | 27.5369 | 23.16 | 9.69 | 32.85 | 50.00 | -17.15 | AVG | P | |
| 11 | 3.0750 | 24.31 | 9.62 | 33.93 | 56.00 | -22.07 | peak | P | |
| 12 | 3.0750 | 13.47 | 9.62 | 23.09 | 46.00 | -22.91 | AVG | P | |

Remark: 1. Factor = Insertion Loss + Cable Loss, Result = Reading + Factor, Margin = Result – Limit.

2. only the data of the worst case record in this report.

4 RADIATED EMISSION

4.1 TEST LIMIT

CFR 47 Part 15, section 15.205

Only spurious emissions are permitted in any of the frequency bands listed the tables in these sections:

| MHz | MHz | MHz | GHz |
|-------------------|---------------------|---------------|-------------|
| 0.090-0.110 | 16.42-16.423 | 399.9-410 | 4.5-5.15 |
| \1\ 0.495-0.505 | 16.69475-16.69525 | 608-614 | 5.35-5.46 |
| 2.1735-2.1905 | 16.80425-16.80475 | 960-1240 | 7.25-7.75 |
| 4.125-4.128 | 25.5-25.67 | 1300-1427 | 8.025-8.5 |
| 4.17725-4.17775 | 37.5-38.25 | 1435-1626.5 | 9.0-9.2 |
| 4.20725-4.20775 | 73-74.6 | 1645.5-1646.5 | 9.3-9.5 |
| 6.215-6.218 | 74.8-75.2 | 1660-1710 | 10.6-12.7 |
| 6.26775-6.26825 | 108-121.94 | 1718.8-1722.2 | 13.25-13.4 |
| 6.31175-6.31225 | 123-138 | 2200-2300 | 14.47-14.5 |
| 8.291-8.294 | 149.9-150.05 | 2310-2390 | 15.35-16.2 |
| 8.362-8.366 | 156.52475-156.52525 | 2483.5-2500 | 17.7-21.4 |
| 8.37625-8.38675 | 156.7-156.9 | 2690-2900 | 22.01-23.12 |
| 8.41425-8.41475 | 162.0125-167.17 | 3260-3267 | 23.6-24.0 |
| 12.29-12.293. | 167.72-173.2 | 3332-3339 | 31.2-31.8 |
| 12.51975-12.52025 | 240-285 | 3345.8-3358 | 36.43-36.5 |
| 12.57675-12.57725 | 322-335.4 | 3600-4400 | (2) |
| 13.36-13.41 | | | |

CFR 47 Part 15, section 15.209

The emissions from an intentional radiator shall not exceed the limits in the tables in these sections using an average detector:

| Frequency (MHz) | Field strength (microvolts/meter) | Measurement distance (meters) |
|-----------------|-----------------------------------|-------------------------------|
| 0.009-0.490 | 2400/F(kHz) | 300 |
| 0.490-1.705 | 24000/F(kHz) | 30 |
| 1.705-30.0 | 30 | 30 |
| 30-88 | 100** | 3 |
| 88-216 | 150** | 3 |
| 216-960 | 200** | 3 |
| Above 960 | 500 | 3 |

Limit calculation and transfer to 3m distance as showed in the following table:

| Frequency (MHz) | Limit (dBuV/m) | Distance (m) |
|-----------------|--|--------------|
| 0.009-0.490 | $20\log(2400/F(\text{KHz})) + 40\log(300/3)$ | 3 |
| 0.490-1.705 | $20\log(24000/F(\text{KHz})) + 40\log(30/3)$ | 3 |
| 1.705-30.0 | 69.5 | 3 |
| 30-88 | 40.0 | 3 |
| 88-216 | 43.5 | 3 |
| 216-960 | 46.0 | 3 |
| Above 960 | 54.0 | 3 |

CFR 47 Part 15, section 15.35

When average radiated emission measurements are specified, the limit on the peak level of the radio Frequency emission is 20dB above the maximum permitted average emission limit.

| Transmitter Spurious Emissions 9KHz-30MHz | | | |
|---|----------|------------|--------------|
| | 9-150KHz | 150-490KHz | 490KHz-30MHz |
| Resolution Bandwidth | 200Hz | 9KHz | 9KHz |
| Video Bandwidth | 2KHz | 100KHz | 100KHz |
| Detector | Peak | Peak | Peak |
| Trace Mode | Max Hold | Max Hold | Max Hold |
| Sweep Time | Auto | Auto | Auto |

4.2 TEST SETUP

1. Radiated Emission Test-Up Frequency Below 30MHz

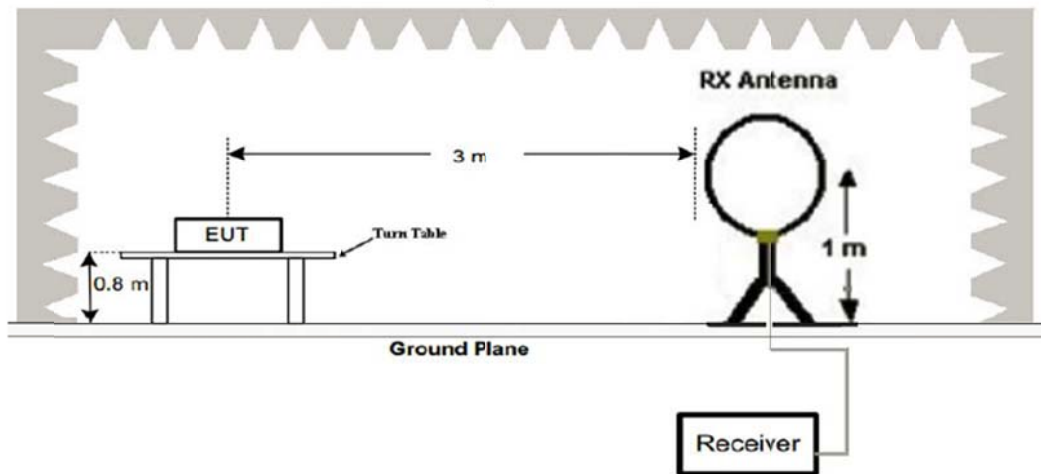

2. Radiated Emission Test-Up Frequency 30MHz~1GHz

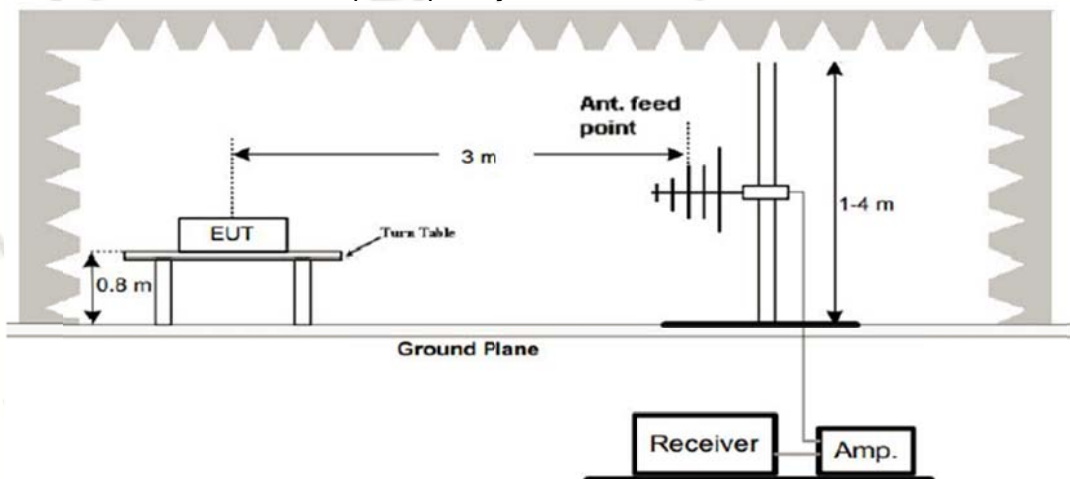

4.3 TEST PROCEDURE

1. Measurement distance is 3m.
2. For the measurement range up to 30MHz in the following plots the field strength result from 3m.
3. Distance measurement are extrapolated to 300m and 30m distance respectively, by 40dB/decade. According to part 15.31(f)(2), per antenna factor scaling.
4. Measurements below 1000MHz are performed with a peak detector and compared to average limits. Measurements with an average detector are not required.

Note:

For battery operated equipment, the equipment tests shall be performed using a new battery.

4.4 TEST RESULT

PASS

For 9KHz-30MHz Test Results:

Coaxial:

| Frequency (MHz) | Detector Mode (PK/QP) | Reading (dBuV) | Factor (dB) | Actual FS (dBuV/m) | Limits 3m (dBuV/m) | Margin (dBuV/m) |
|-----------------|-----------------------|----------------|-------------|--------------------|--------------------|-----------------|
| 0.125 | PK | 73.57 | 15.48 | 89.05 | 105.67 | -16.62 |
| 0.741 | PK | 40.7 | 15.98 | 56.68 | 70.21 | -13.53 |
| 1.834 | PK | 29.59 | 16.2 | 45.79 | 69.5 | -23.71 |
| 2.678 | PK | 36.36 | 15.2 | 51.56 | 69.5 | -17.94 |
| 5.493 | PK | 39.92 | 15.68 | 55.6 | 69.5 | -13.9 |
| 8.762 | PK | 38.61 | 15.6 | 54.21 | 69.5 | -15.29 |

Coplaner:

| Frequency (MHz) | Detector Mode (PK/QP) | Reading (dBuV) | Factor (dB) | Actual FS (dBuV/m) | Limits 3m (dBuV/m) | Margin (dBuV/m) |
|-----------------|-----------------------|----------------|-------------|--------------------|--------------------|-----------------|
| 0.125 | PK | 82.13 | 15.48 | 97.61 | 105.67 | -8.06 |
| 0.764 | PK | 72.32 | 15.98 | 88.3 | 69.94 | 18.36 |
| 1.725 | PK | 65.86 | 16.2 | 82.06 | 69.5 | 12.56 |
| 2.931 | PK | 31.14 | 15.2 | 46.34 | 69.5 | -23.16 |
| 5.672 | PK | 30.09 | 15.68 | 45.77 | 69.5 | -23.73 |
| 8.564 | PK | 30.28 | 15.6 | 45.88 | 69.5 | -23.62 |

For 30MHz-1GHz Test Results:

| | | | |
|---------------|---------------------------------|--------------------|------------|
| Temperature: | 24°C | Relative Humidity: | 48% |
| Test Date: | May 26, 2023 | Pressure: | 1010hPa |
| Test Voltage: | AC 120V, 60Hz | Phase: | Horizontal |
| Test Mode: | Transmitting mode 1 of 125.0kHz | | |

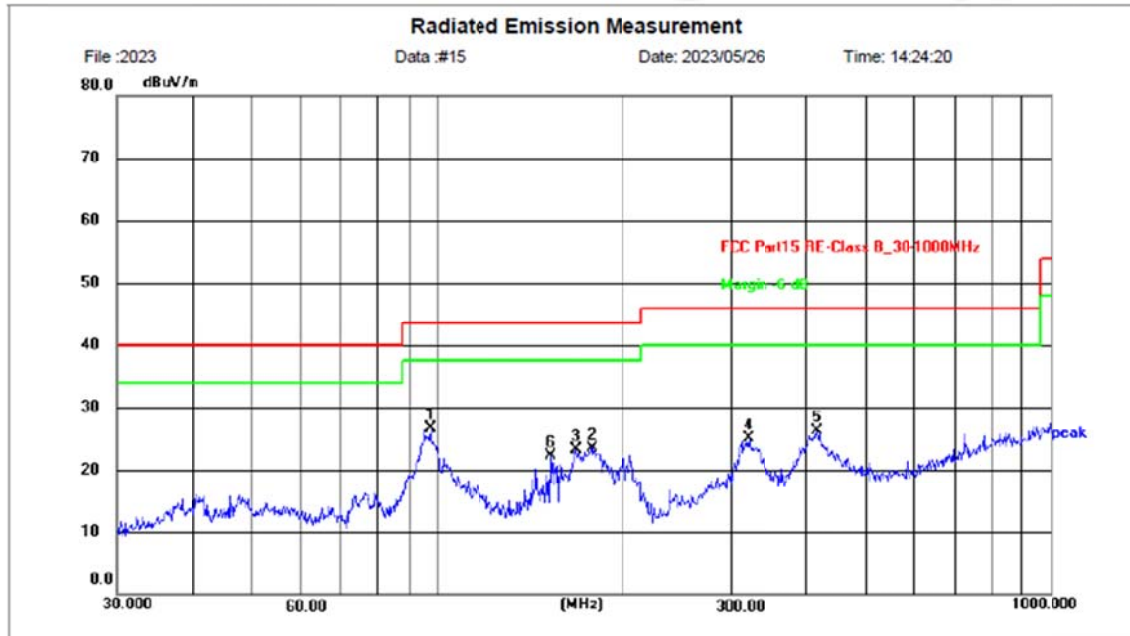

| No. | Frequency (MHz) | Reading (dBuV) | Factor (dB/m) | Level (dBuV/m) | Limit (dBuV/m) | Margin (dB) | Detector | Height (cm) | Azimuth (deg.) | P/F | Remark |
|-----|-----------------|----------------|---------------|----------------|----------------|-------------|----------|-------------|----------------|-----|--------|
| 1 * | 97.1148 | 46.68 | -20.01 | 26.67 | 43.50 | -16.83 | peak | 100 | 149 | P | |
| 2 | 178.1324 | 41.36 | -17.76 | 23.60 | 43.50 | -19.90 | peak | 100 | 201 | P | |
| 3 | 167.8240 | 39.64 | -16.30 | 23.34 | 43.50 | -20.16 | peak | 100 | 296 | P | |
| 4 | 321.0605 | 40.57 | -15.39 | 25.18 | 46.00 | -20.82 | peak | 100 | 312 | P | |
| 5 | 416.1791 | 39.01 | -12.77 | 26.24 | 46.00 | -19.76 | peak | 100 | 97 | P | |
| 6 | 152.6640 | 38.17 | -15.82 | 22.35 | 43.50 | -21.15 | peak | 100 | 103 | P | |

Remark: Absolute Level = Reading Level + Factor, Margin = Absolute Level – Limit
 Factor = Ant. Factor + Cable Loss – Pre-amplifier

| | | | |
|---------------|---------------------------------|--------------------|----------|
| Temperature: | 24°C | Relative Humidity: | 48% |
| Test Date: | May 26, 2023 | Pressure: | 1010hPa |
| Test Voltage: | AC 120V, 60Hz | Phase: | Vertical |
| Test Mode: | Transmitting mode 1 of 125.0kHz | | |

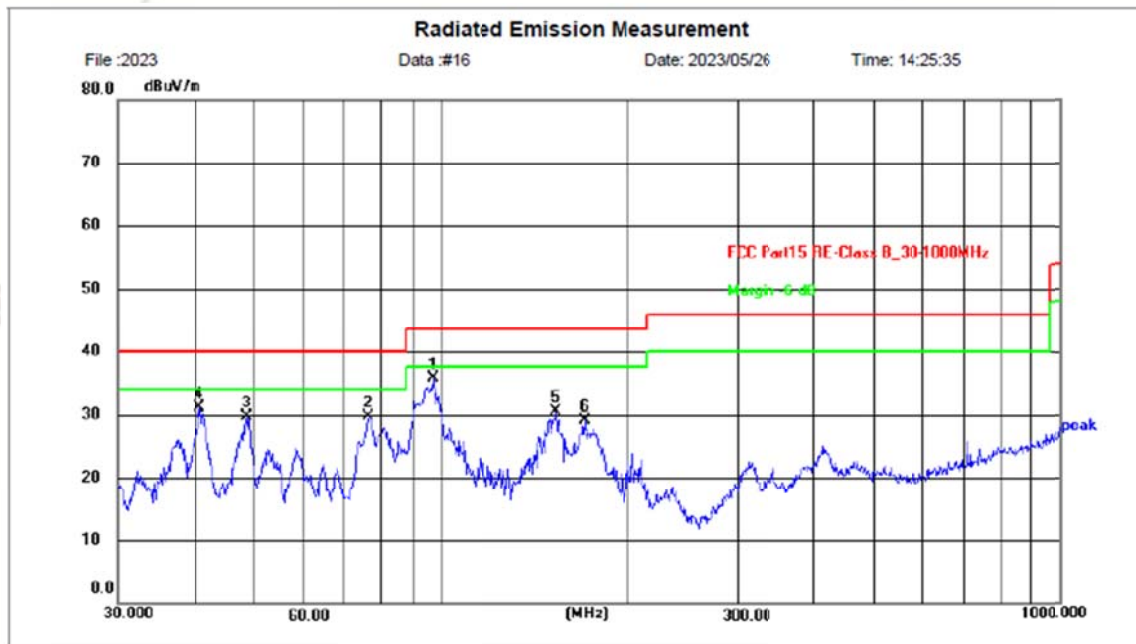

| No. | Frequency (MHz) | Reading (dBuV) | Factor (dB/m) | Level (dBuV/m) | Limit (dBuV/m) | Margin (dB) | Detector | Height (cm) | Azimuth (deg.) | P/F | Remark |
|-----|-----------------|----------------|---------------|----------------|----------------|-------------|----------|-------------|----------------|-----|--------|
| 1 * | 96.7750 | 55.63 | -20.02 | 35.61 | 43.50 | -7.89 | peak | 100 | 321 | P | |
| 2 | 76.5119 | 49.46 | -19.83 | 29.63 | 40.00 | -10.37 | peak | 100 | 143 | P | |
| 3 | 48.5015 | 46.21 | -16.42 | 29.79 | 40.00 | -10.21 | peak | 100 | 196 | P | |
| 4 | 40.7014 | 46.81 | -15.73 | 31.08 | 40.00 | -8.92 | peak | 100 | 210 | P | |
| 5 | 153.2000 | 46.39 | -15.83 | 30.56 | 43.50 | -12.94 | peak | 100 | 279 | P | |
| 6 | 170.1947 | 45.59 | -16.44 | 29.15 | 43.50 | -14.35 | peak | 100 | 45 | P | |

Remark: Absolute Level = Reading Level + Factor, Margin = Absolute Level – Limit
 Factor = Ant. Factor + Cable Loss – Pre-amplifier

Remark:

- * denotes emission frequency which appearing within the Restricted Bands specified in provision of 15.205, then the general radiated emission limits in 15.209 apply.
- The IF bandwidth of EMI Test Receiver between 30MHz to 1GHz was 120KHz, 1 MHz for measuring above 1 GHz, below 30MHz was 10KHz.
- Only the data of the worst case record in this report.

5 ANTENNA REQUIREMENT

Standard Applicable:

For intentional device, according to FCC 47 CFR Section 15.203, an intentional radiator shall be designed to ensure that no antenna other than that furnished by the responsible party shall be used with the device.

Antenna Connected Construction:

The antenna used in this product is Coil Antenna, The directional gains of antenna used for transmitting is 0dBi.

ANTENNA:

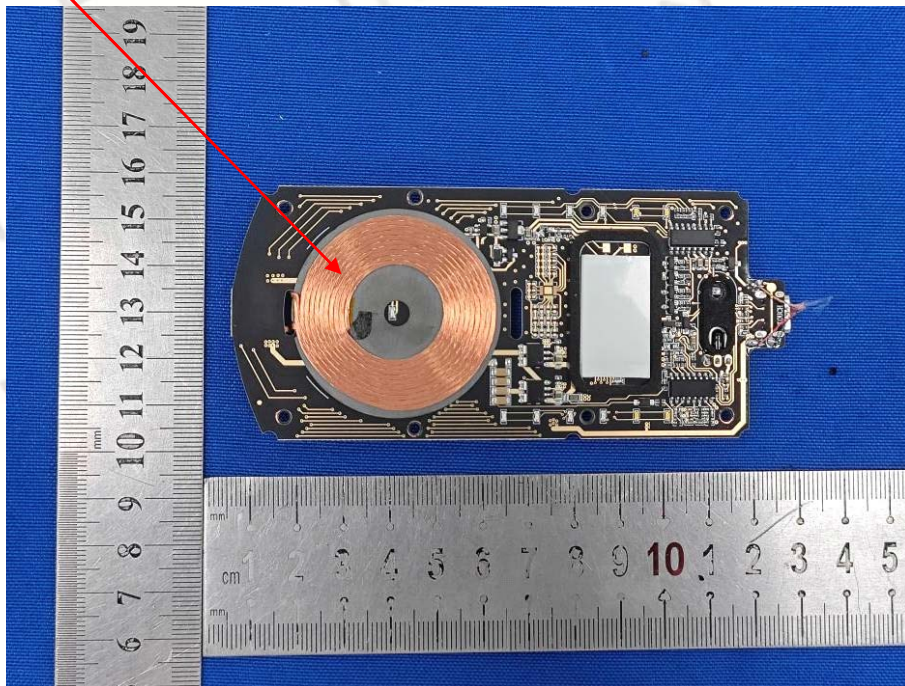

6 PHOTO OF TEST

6.1 RADIATED EMISSION

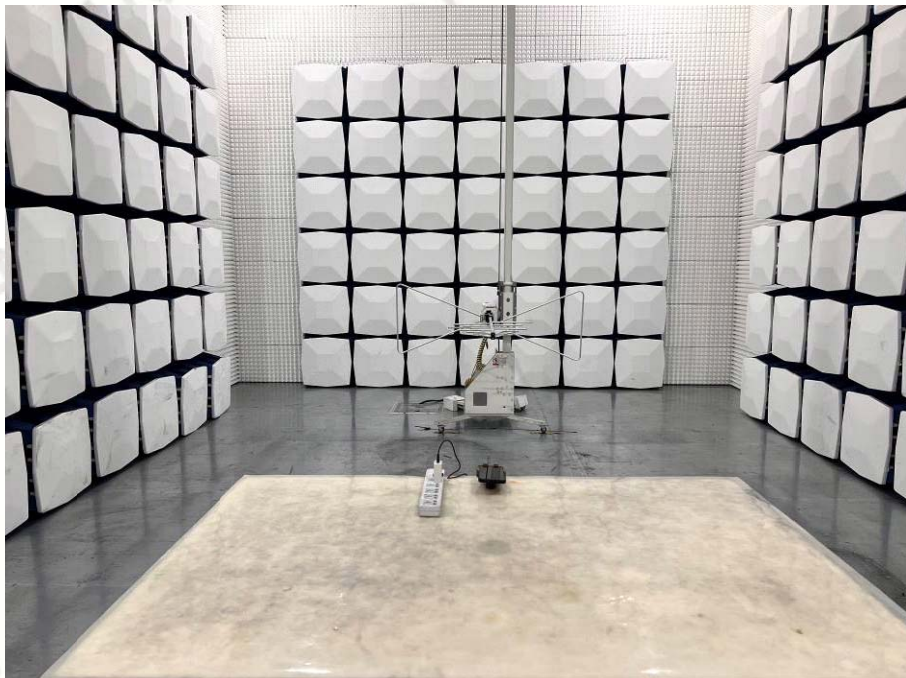

6.2 CONDUCTED EMISSION



End of Report