

# SPECIFICATION FOR APPROVAL

## 1. MECHANICAL DIMENSION (UNIT:mm)

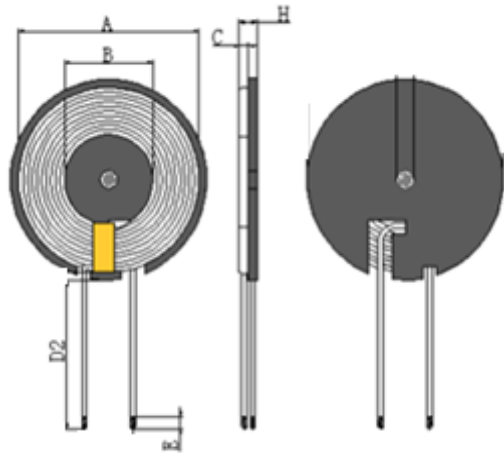

## 2. SCHEMATICS:

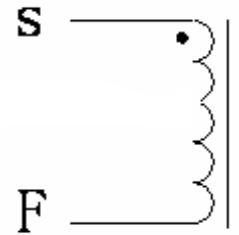

A	B	C	D2	E	H	备注
44.5±0.05	20.5±0.5	0.5±0.05	15±2	3±2	1.7MAX	备注: 1. 磁片外径44-44.5为主 2. 线圈外径尺寸41

## 3. WINDING:

STEP	START-FINISH	WIRE TYPE	TURNS	TAPE	REMARK
N1	S-F	热风线 0.08*24*2P 2UEW	10TS (Ref)		

## 4. ELECTRICAL SPECIFICATION:

ITEM	L	DCR	Q值	HI-POT
TEST	线圈加磁片	S-F		
CON	100KHz, 0.25V	AT 25°C		
SPEC	6.5uH±10%	85mΩ Max	45	

## 5. BILF OF MATERIAL:

NO.	ITEM	MATERIAL SPECIFICATION	MANUFACTURER	SGS NO.
1	热风线0.08*24*2股	热风线0.08*24*2股	NANJINGJINNINGCO,LTD	

2	无铅锡条	无铅锡条	QIAODO	
3	磁片	45*0.5锰锌硬磁片开L槽	TAIYI CO.,LTD	
4	胶水	黄胶9999	LIANCHENG CO.,LTD	
5	高温胶纸	8mm宽高温胶纸	CUDAK CO.,LTD	
6	背胶	43.8*0.1	CUDAK CO.,LTD	
7				
HRSW ELECTRONICS CO.,LTD			PART NO	
			TITLE	G45开槽超薄+背胶 15长 (MM)
DRAWN BY		CHECKED BY		APPROVED BY
何伟华		韦小红		韦小红