



FCC Test Report

Report Reference No.....: **HK2407314284-6E**
FCC ID.....: **2BBBN-VISIONSYNC**
Compiled by
(position+printed name+signature)...: RF Department Manager Len Liao

Len Liao

Supervised by
(position+printed name+signature)...: Technical Manager Sliver Wan

Sliver Wan

Approved by
(position+printed name+signature)...: General Manager Jason Zhou

Jason Zhou

Date of issue.....: Aug. 20, 2024

Testing Laboratory Name: **Shenzhen HUAKE Testing Technology Co., Ltd.**

Address.....: 1-2/F., Building B2, Junfeng Zhongcheng Zhizao Innovation Park,
Heping, Fuhai Street, Bao'an District, Shenzhen, Guangdong, China

Applicant's name: **Hangzhou Tanlink Technology Co.,Ltd.**

Address.....: Room 701, South Building, Building 3, No.16, Longtan Road,
Cangqian Street, Yuhang District, Hangzhou, Zhejiang, China

Test specification :

Standard : **FCC Part 27**

Shenzhen HUAKE Testing Technology Co., Ltd.All rights reserved.

This publication may be reproduced in whole or in part for non-commercial purposes as long as the Shenzhen HUAKE Testing Technology Co., Ltd.as copyright owner and source of the material. Shenzhen HUAKE Testing Technology Co., Ltd.takes no responsibility for and will not assume liability for damages resulting from the reader's interpretation of the reproduced material due to its placement and context.

Test item description: 4G driving recorder

Trade Mark: Redtiger

Manufacturer: **Shanghai Stoneoim Intelligent Technology Co., Ltd.**

Model/Type reference.....: VisionSync 10

Series Models: VisionSync 30, VisionSync 30 Pro, VisionSync 50, VisionSync 50 Pro, VisionSync 70, VisionSync 70 Pro, VisionSync 90, VisionSync 90 Pro, LinkStream 10, LinkStream 30

Ratings.....: DC 5V from Type-C

Modulation: QPSK, 16QAM

Hardware version: V2.0

Software version: V2.0

Frequency.....: LTE Band 17

Result.....: **PASS**



TEST REPORT

Test Report No. :	HK2407314284-6E	Aug. 20, 2024
		Date of issue

Equipment under Test : 4G driving recorder

Model /Type : VisionSync 10

Series Models : VisionSync 30, VisionSync 30 Pro, VisionSync 50, VisionSync 50 Pro, VisionSync 70, VisionSync 70 Pro, VisionSync 90, VisionSync 90 Pro, LinkStream 10, LinkStream 30

Applicant : **Hangzhou Tanlink Technology Co.,Ltd.**

Address : Room 701, South Building, Building 3, No.16, Longtan Road, Cangqian Street, Yuhang District, Hangzhou, Zhejiang, China

Manufacturer : **Hangzhou Tanlink Technology Co.,Ltd.**

Address : Room 701, South Building, Building 3, No.16, Longtan Road, Cangqian Street, Yuhang District, Hangzhou, Zhejiang, China

Test result	Pass
--------------------	-------------

The test report merely corresponds to the test sample.
It is not permitted to copy extracts of these test result without the written permission of the test laboratory.



Contents

1	SUMMARY	4
1.1	Test Standards	4
1.2	Test Description	4
1.3	Test Facility	5
1.3.1	Information of The Test Laboratory	5
1.4	Statement of The Measurement Uncertainty	5
2	GENERAL INFORMATION	6
2.1	Environmental Conditions	6
2.2	Description of Test Modes	6
2.3	Equipments Used During The Test	7
2.4	Modifications	8
3	TEST CONDITIONS AND RESULTS	9
3.1	Output Power	9
3.2	Radiated Measurement:	11
3.3	Peak-to-Average Ratio (PAR)	12
3.4	Occupied Bandwidth and Emission Bandwidth	15
3.5	Band Edge compliance	18
3.6	Spurious Emission	21
3.7	Frequency Stability under Temperature & Voltage Variations	32
4	TEST SETUP PHOTOS OF THE EUT	34
5	PHOTOS OF THE EUT	35



1 SUMMARY

1.1 Test Standards

The tests were performed according to following standards:

FCC Part 27: MISCELLANEOUS WIRELESS COMMUNICATIONS SERVICES

TIA/EIA 603 D June 2010: Land Mobile FM or PM Communications Equipment Measurement and Performance Standards.
47 CFR FCC Part 15 Subpart B: - Unintentional Radiators

FCC Part 2: FREQUENCY ALLOCATIONS AND RADIO TREATY MATTERS; GENERAL RULES AND REGULATIONS

KDB971168 D01: MEASUREMENT GUIDANCE FOR CERTIFICATION OF LICENSED DIGITAL TRANSMITTERS

1.2 Test Description

Test Item	FCC Rule No.	Result
RF Output Power	Part 2.1046 Part 27.50(c)(10)	Pass
Peak-to-Average Ratio	Part 2.1046	Pass
99% & -26 dB Occupied Bandwidth	Part 2.1049	Pass
Spurious Emissions at Antenna Terminal	Part 2.1051 Part 27.53(g)	Pass
Field Strength of Spurious Radiation	Part 2.1053 Part 27.53(g)	Pass
Out of band emission, Band Edge	Part 2.1051 Part 27.53(g)	Pass
Frequency stability	Part 2.1055 Part 27.54	Pass

The results shown in this test report refer only to the sample(s) tested unless otherwise stated and the sample(s) are retained for 30 days only. The document is issued by HUAK, this document cannot be reproduced except in full with our prior written permission. The more details and the authenticity of the report will be confirmed at <http://www.cer-mark.com>.



1.3 Test Facility

1.3.1 Information of The Test Laboratory

Shenzhen HUAKE Testing Technology Co., Ltd.
Add.: 1-2/F., Building B2, Junfeng Zhongcheng Zhizao Innovation Park, Heping,
Fuhai Street, Bao'an District, Shenzhen, Guangdong, China

Testing Laboratory Authorization:

A2LA Accreditation Code is 4781.01.
FCC Designation Number is CN1229.
Canada IC CAB identifier is CN0045.
CNAS Registration Number is L9589.

1.4 Statement of The Measurement Uncertainty

The data and results referenced in this document are true and accurate. The reader is cautioned that there may be errors within the calibration limits of the equipment and facilities. The measurement uncertainty was calculated for all measurements listed in this test report acc. to CISPR 16 - 4 „Specification for radio disturbance and immunity measuring apparatus and methods – Part 4: Uncertainty in EMC Measurements“ and is documented in the Shenzhen HUAKE Testing Technology Co., Ltd.. quality system acc. to DIN EN ISO/IEC 17025. Furthermore, component and process variability of devices similar to that tested may result in additional deviation. The manufacturer has the sole responsibility of continued compliance of the device.

Hereafter the best measurement capability for Shenzhen HUAKE Testing Technology Co., Ltd.

Test	Range	Measurement Uncertainty	Notes
Radiated Emission	30~1000MHz	4.10dB	(1)
Radiated Emission	Above 1GHz	4.32dB	(1)
Conducted Disturbance	0.15~30MHz	3.20dB	(1)

(1) This uncertainty represents an expanded uncertainty expressed at approximately the 95% confidence level using a coverage factor of k=2.



2 GENERAL INFORMATION

2.1 Environmental Conditions

During the measurement the environmental conditions were within the listed ranges:

Normal Temperature:	25°C
Relative Humidity:	55 %
Air Pressure:	101 kPa

2.2 Description of Test Modes

The EUT has been tested under typical operating condition. The CMW500 used to control the EUT staying in continuous transmitting and receiving mode for testing. Regards to the frequency band operation: the lowest, middle and highest frequency of channel were selected to perform the test, then shown on this report.

Note:

1. For the ERP/EIRP and radiated emission test, every axis (X, Y, Z) was verified, and show the worst result on this report.
2. Test method and refer to 3GPP TS136521.



2.3 Equipments Used During The Test

Item	Test Equipment	Manufacturer	Model No.	Serial No.	Calibration Date	Calibration Due Date
1	L.I.S.N.	R&S	ENV216	HKE-002	2024/02/20	2025/02/19
2	L.I.S.N.	R&S	ENV216	HKE-059	2024/02/20	2025/02/19
3	EMI Test Receiver	R&S	ESR	HKE-005	2024/02/20	2025/02/19
4	Spectrum analyzer	Agilent	N9020A	HKE-048	2024/02/20	2025/02/19
5	Spectrum analyzer	R&S	FSV3044	HKE-126	2024/02/20	2025/02/19
6	Preamplifier	EMCI	EMC051845 S	HKE-006	2024/02/20	2025/02/19
7	Preamplifier	Schwarzbeck	BBV 9743	HKE-016	2024/02/20	2025/02/19
8	Preamplifier	A.H. Systems	SAS-574	HKE-182	2024/02/20	2025/02/19
9	6d Attenuator	Pasternack	6db	HKE-184	2024/02/20	2025/02/19
10	EMI Test Receiver	Rohde & Schwarz	ESR-7	HKE-010	2024/02/20	2025/02/19
11	Broadband Antenna	Schwarzbeck	VULB9168	HKE-167	2024/02/21	2026/02/20
12	Loop Antenna	COM-POWER	AL-130R	HKE-014	2024/02/21	2026/02/20
13	Horn Antenna	Schwarzbeck	9120D	HKE-013	2024/02/21	2026/02/20
14	EMI Test Software	Tonscend	JS32-CE 2.5.0.6	HKE-081	/	/
15	EMI Test Software	Tonscend	JS32-RE 5.0.0	HKE-082	/	/
16	RF Automatic control unit	Tonscend	JS0806-1	HKE-096	2024/02/20	2025/02/19
17	High pass filter unit	Tonscend	JS0806-F	HKE-055	2024/02/20	2025/02/19
18	Wireless Communication Test Set	R&S	CMU200	HKE-026	2024/02/20	2025/02/19
19	Wireless Communication Test Set	R&S	CMW500	HKE-027	2024/02/20	2025/02/19
20	High-low temperature chamber	Guangke	HT-80L	HKE-118	2024/06/10	2025/06/09
21	Temperature and humidity meter	Boyang	HTC-1	HKE-075	2024/06/10	2025/06/09
22	RF Test Software	Tonscend	JS1120 Version 3.1.46	HKE-183	/	/

The results shown in this test report refer only to the sample(s) tested unless otherwise stated and the sample(s) are retained for 30 days only. The document is issued by HUAK, this document cannot be reproduced except in full with our prior written permission. The more details and the authenticity of the report will be confirmed at <http://www.cer-mark.com>.

TEL : +86-755 2302 9901 FAX : +86-755 2302 9901 E-mail : service@cer-mark.com

Add: 1-2F., Building B2, Junfeng Zhongcheng Zhizao Innovation Park, Heping Community, Fuhai Street, Bao'an District, Shenzhen, Guangdong, China



2.4 Modifications

No modifications were implemented to meet testing criteria.

3 TEST CONDITIONS AND RESULTS

3.1 Output Power

LIMIT

Portable stations (hand-held devices) in the 600 MHz uplink band and the 698-746 MHz band, and fixed and mobile stations in the 600 MHz uplink band are FCC limited to 3 watts ERP."IC limited to 5 watts ERP."

TEST CONFIGURATION

Conducted Power Measurement

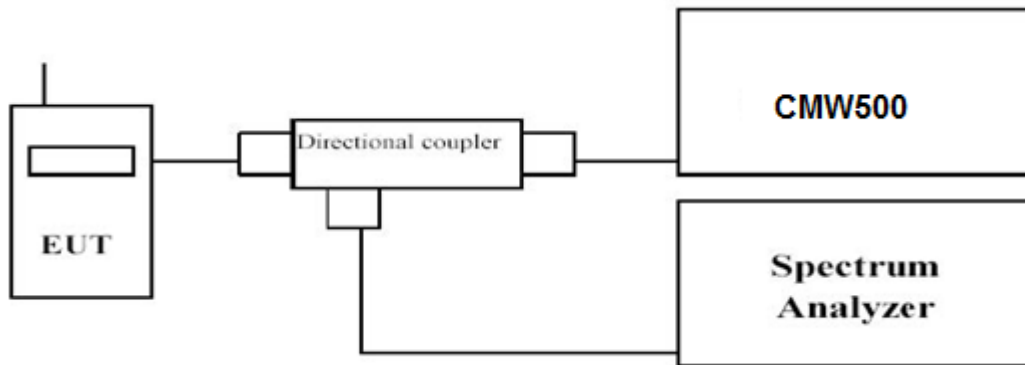

Radiated Power Measurement:

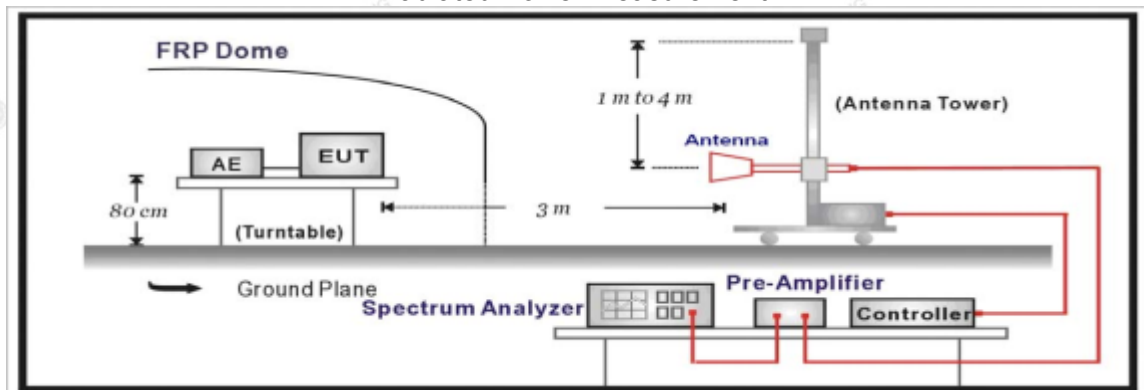

TEST PROCEDURE

The EUT was setup according to EIA/TIA 603D

Conducted Power Measurement:

- Place the EUT on a bench and set it in transmitting mode.
- Connect a low loss RF cable from the antenna port to a spectrum analyzer and CMW500 by a Directional Couple.
- EUT Communicate with CMW500, then select a channel for testing.
- Add a correction factor to the display of spectrum, and then test.

Radiated Power Measurement:

- The EUT shall be placed at the specified height on a support, and in the position closest to normal use as declared by provider.
- The test antenna shall be oriented initially for vertical polarization and shall be chosen to correspond to the frequency of the transmitter
- The output of the test antenna shall be connected to the measuring receiver.
- The transmitter shall be switched on and the measuring receiver shall be tuned to the frequency of the transmitter under test.



- e. The test antenna shall be raised and lowered through the specified range of height until a maximum signal level is detected by the measuring receiver.
- f. The transmitter shall then be rotated through 360° in the horizontal plane, until the maximum signal level is detected by the measuring receiver.
- g. The test antenna shall be raised and lowered again through the specified range of height until a maximum signal level is detected by the measuring receiver.
- h. The maximum signal level detected by the measuring receiver shall be noted.
- i. The transmitter shall be replaced by a substitution antenna.
- j. The substitution antenna shall be orientated for vertical polarization and the length of the substitution antenna shall be adjusted to correspond to the frequency of the transmitter.
- k. The substitution antenna shall be connected to a calibrated signal generator.
- l. If necessary, the input attenuator setting of the measuring receiver shall be adjusted in order to increase the sensitivity of the measuring receiver.
- m. The test antenna shall be raised and lowered through the specified range of height to ensure that the maximum signal is received.
- n. The input signal to the substitution antenna shall be adjusted to the level that produces a level detected by the measuring receiver, that is equal to the level noted while the transmitter radiated power was measured, corrected for the change of input attenuator setting of the measuring receiver.
- o. The measurement shall be repeated with the test antenna and the substitution antenna orientated for horizontal polarization.
- p. The measure of the effective radiated power is the larger of the two levels recorded at the input to the substitution antenna, corrected for gain of the substitution antenna if necessary.
- q. Test site anechoic chamber refer to ANSI C63.4.

TEST RESULTS

Conducted Measurement:

LTE FDD Band 17				
TX Channel Bandwidth	RB Size/Offset	Frequency (MHz)	Average Power [dBm]	
			QPSK	16QAM
5 MHz	1 RB low	706.5	23.36	21.31
		710.0	23.35	21.34
		713.5	23.39	21.37
	1 RB high	706.5	22.07	21.08
		710.0	22.06	21.08
		713.5	22.22	21.12
	50% RB mid	706.5	21.95	21.21
		710.0	23.08	21.70
		713.5	23.13	21.76
	100% RB	706.5	23.15	21.75
		710.0	22.02	21.08
		713.5	22.17	21.11
10 MHz	1 RB low	709.0	23.01	22.12
		710.0	22.96	22.07
		711.0	23.08	22.21
	1 RB high	709.0	22.01	21.03
		710.0	22.01	21.03
		711.0	22.27	21.02
	50% RB mid	709.0	22.02	21.04
		710.0	23.17	21.52
		711.0	23.17	21.64
	100% RB	709.0	23.18	21.62
		710.0	22.19	21.19
		711.0	22.18	21.18

The results shown in this test report refer only to the sample(s) tested unless otherwise stated and the sample(s) are retained for 30 days only. The document is issued by HUAKE, this document cannot be reproduced except in full with our prior written permission. The more details and the authenticity of the report will be confirmed at <http://www.cer-mark.com>.



3.2 Radiated Measurement:

Remark:

1. We were tested all RB Configuration refer 3GPP TS136 521 for each Channel Bandwidth of LTE FDD Band 17; recorded worst case for each Channel Bandwidth of LTE FDD Band 17.
2. $EIRP = P_{Mea}(dBm) - P_{cl}(dB) + P_{Ag}(dB) + G_a(dBi)$
3. $ERP = EIRP - 2.15dBi$ as EIRP by subtracting the gain of the dipole.

LTE FDD Band 17_Channel Bandwidth 5MHz_QPSK

Frequency (MHz)	P _{Mea} (dBm)	P _{cl} (dB)	G _a Antenna Gain(dB)	Correction (dB)	P _{Ag} (dB)	ERP (dBm)	FCC Limit (dBm)	IC Limit (dBm)	Polarization
706.5	-21.43	2.38	8.23	2.15	36.7	18.97	34.77	36.99	V
710.0	-19.5	2.4	8.29	2.15	36.7	20.94	34.77	36.99	V
713.5	-19.37	2.43	8.28	2.15	36.7	21.03	34.77	36.99	V

LTE FDD Band 17_Channel Bandwidth 10MHz_QPSK

Frequency (MHz)	P _{Mea} (dBm)	P _{cl} (dB)	G _a Antenna Gain(dB)	Correction (dB)	P _{Ag} (dB)	ERP (dBm)	FCC Limit (dBm)	IC Limit (dBm)	Polarization
709.0	-22.1	2.38	8.23	2.15	36.7	18.3	34.77	36.99	V
710.0	-19	2.4	8.29	2.15	36.7	21.44	34.77	36.99	V
711.0	-19.45	2.43	8.28	2.15	36.7	20.95	34.77	36.99	V

LTE FDD Band 17_Channel Bandwidth 5MHz_16QAM

Frequency (MHz)	P _{Mea} (dBm)	P _{cl} (dB)	G _a Antenna Gain(dB)	Correction (dB)	P _{Ag} (dB)	ERP (dBm)	FCC Limit (dBm)	IC Limit (dBm)	Polarization
706.5	-21.48	2.38	8.23	2.15	36.7	18.92	34.77	36.99	V
710.0	-19.49	2.4	8.29	2.15	36.7	20.95	34.77	36.99	V
713.5	-19.84	2.43	8.28	2.15	36.7	20.56	34.77	36.99	V

LTE FDD Band 17_Channel Bandwidth 10MHz_16QAM

Frequency (MHz)	P _{Mea} (dBm)	P _{cl} (dB)	G _a Antenna Gain(dB)	Correction (dB)	P _{Ag} (dB)	ERP (dBm)	FCC Limit (dBm)	IC Limit (dBm)	Polarization
709.0	-21.58	2.38	8.23	2.15	36.7	18.82	34.77	36.99	V
710.0	-19.57	2.4	8.29	2.15	36.7	20.87	34.77	36.99	V
711.0	-19.92	2.43	8.28	2.15	36.7	20.48	34.77	36.99	V



3.3 Peak-to-Average Ratio (PAR)

LIMIT

The Peak-to-Average Ratio (PAR) of the transmission may not exceed 13 dB.

TEST CONFIGURATION

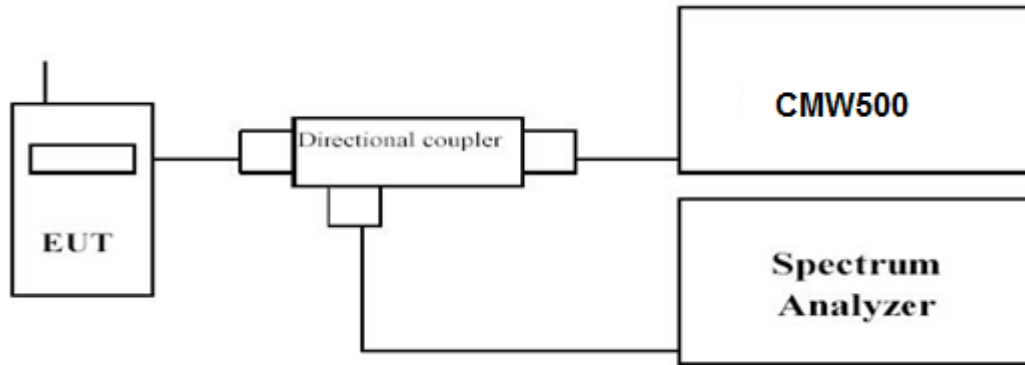

TEST PROCEDURE

1. Refer to instrument’s analyzer instruction manual for details on how to use the power statistics/CCDF function;
2. Set resolution/measurement bandwidth \geq signal’s occupied bandwidth;
3. Set the number of counts to a value that stabilizes the measured CCDF curve;
4. Set the measurement interval as follows:
 - 1). for continuous transmissions, set to 1 ms,
 - 2). for burst transmissions, employ an external trigger that is synchronized with the EUT burst timing sequence, or use the internal burst trigger with a trigger level that allows the burst to stabilize and set the measurement interval to a time that is less than or equal to the burst duration.
5. Record the maximum PAPR level associated with a probability of 0.1%.

TEST RESULTS

Remark:

1. We were tested all RB Configuration refer 3GPP TS136 521 for each Channel Bandwidth of LTE FDD Band 17; recorded worst case for each Channel Bandwidth of LTE FDD Band 17.

LTE FDD Band 17				
TX Channel Bandwidth	Frequency (MHz)	RB Size/Offset	PAPR (dB)	
			QPSK	16QAM
5 MHz	706.5	1RB#0	5.46	6.09
	710.0		5.40	6.09
	713.5		5.39	6.10
10 MHz	709.0	1RB#0	5.58	6.47
	710.0		5.59	6.46
	711.0		5.34	6.17



LTE FDD Band 17-5MHz Channel Bandwidth PAPR

QPSK

16QAM

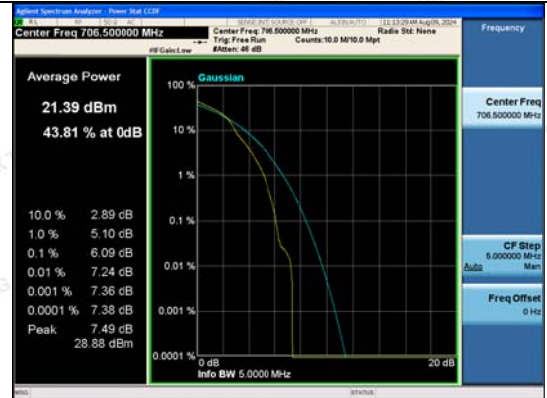
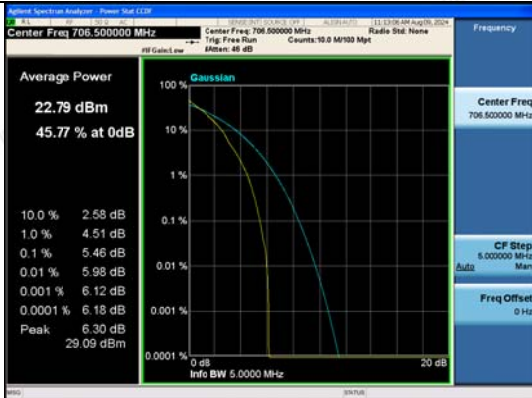

1RB#0

1RB#0

Low Channel

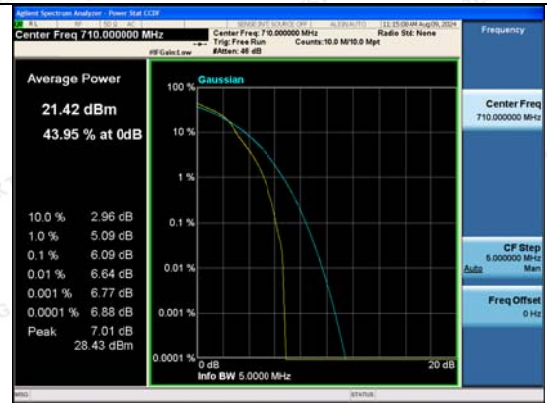

1RB#0

1RB#0

Middle Channel



1RB#0

1RB#0

High Channel

The results shown in this test report refer only to the sample(s) tested unless otherwise stated and the sample(s) are retained for 30 days only. The document is issued by HUAJ, this document cannot be reproduced except in full with our prior written permission. The more details and the authenticity of the report will be confirmed at <http://www.cer-mark.com>.

TEL : +86-755 2302 9901 FAX : +86-755 2302 9901 E-mail : service@cer-mark.com

Add: 1-2F., Building B2, Junfeng Zhongcheng Zhizao Innovation Park, Heping Community, Fuhai Street, Bao'an District, Shenzhen, Guangdong, China



LTE FDD Band 17-10MHz Channel Bandwidth PAPR

QPSK

16QAM

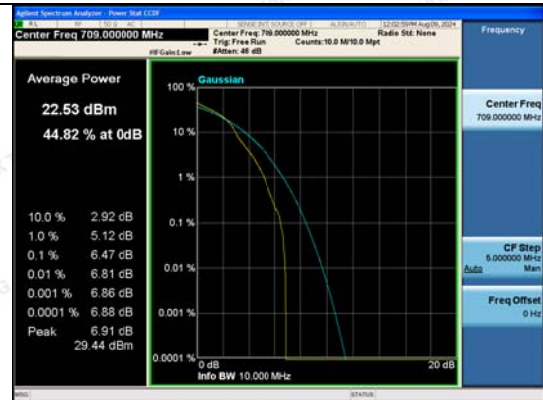
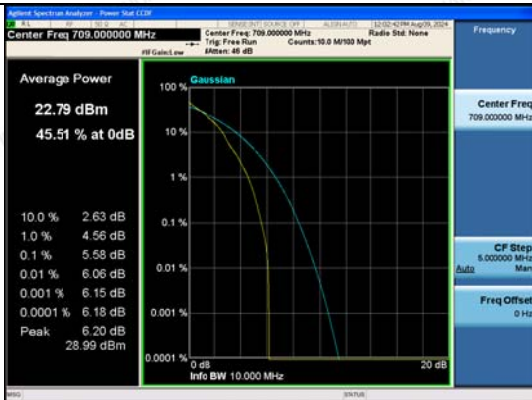

1RB#0

1RB#0

Low Channel

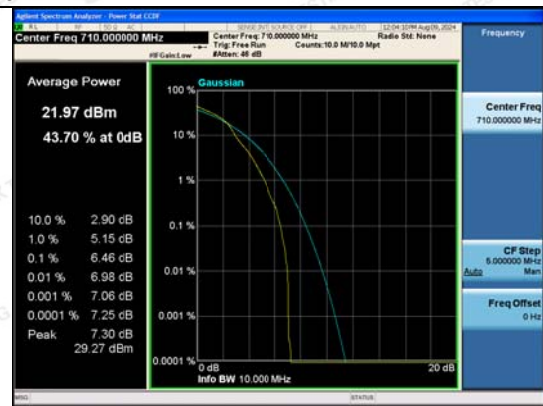
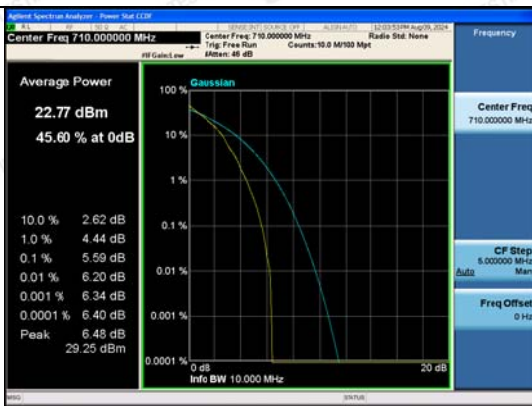

1RB#0

1RB#0

Middle Channel



1RB#0

1RB#0

High Channel

The results shown in this test report refer only to the sample(s) tested unless otherwise stated and the sample(s) are retained for 30 days only. The document is issued by HUAJ, this document cannot be reproduced except in full with our prior written permission. The more details and the authenticity of the report will be confirmed at <http://www.cer-mark.com>.

TEL : +86-755 2302 9901 FAX : +86-755 2302 9901 E-mail : service@cer-mark.com

Add: 1-2F., Building B2, Junfeng Zhongcheng Zhizao Innovation Park, Heping Community, Fuhai Street, Bao'an District, Shenzhen, Guangdong, China



3.4 Occupied Bandwidth and Emission Bandwidth

LIMIT

N/A

TEST CONFIGURATION

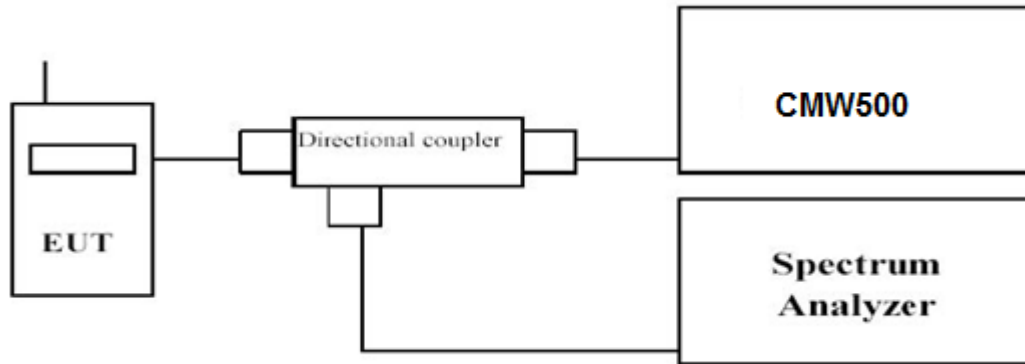

TEST PROCEDURE

The transmitter output was connected to a calibrated coaxial cable and coupler, the other end of which was connected to a spectrum analyzer. The occupied bandwidth was measured with the spectrum analyzer at low, middle and high channel in each band. The -26dBc Emission bandwidth was also measured and recorded. Set RBW was set to about 1% of emission BW, VBW≥3 times RBW. -26dBc display line was placed on the screen (or 99% bandwidth), the occupied bandwidth is the delta frequency between the two points where the display line intersects the signal trace.

TEST RESULTS

Remark:

1. We were tested all RB Configuration refer 3GPP TS136 521 for each Channel Bandwidth of LTE FDD Band 17; recorded worst case for each Channel Bandwidth of LTE FDD Band 17.

LTE FDD Band 17						
TX Channel Bandwidth	RB Size/Offset	Frequency (MHz)	-26dBc Emission bandwidth (MHz)		99% Occupied bandwidth (MHz)	
			QPSK	16QAM	QPSK	16QAM
5 MHz	25RB#0	706.5	4.966	4.957	4.5059	4.5023
		710.0	4.976	4.972	4.4935	4.5030
		713.5	4.995	5.000	4.5155	4.5325
10 MHz	50RB#0	709.0	9.853	9.898	8.9593	8.9607
		710.0	9.850	9.884	8.9738	8.9730
		711.0	9.871	9.922	8.9489	8.9793

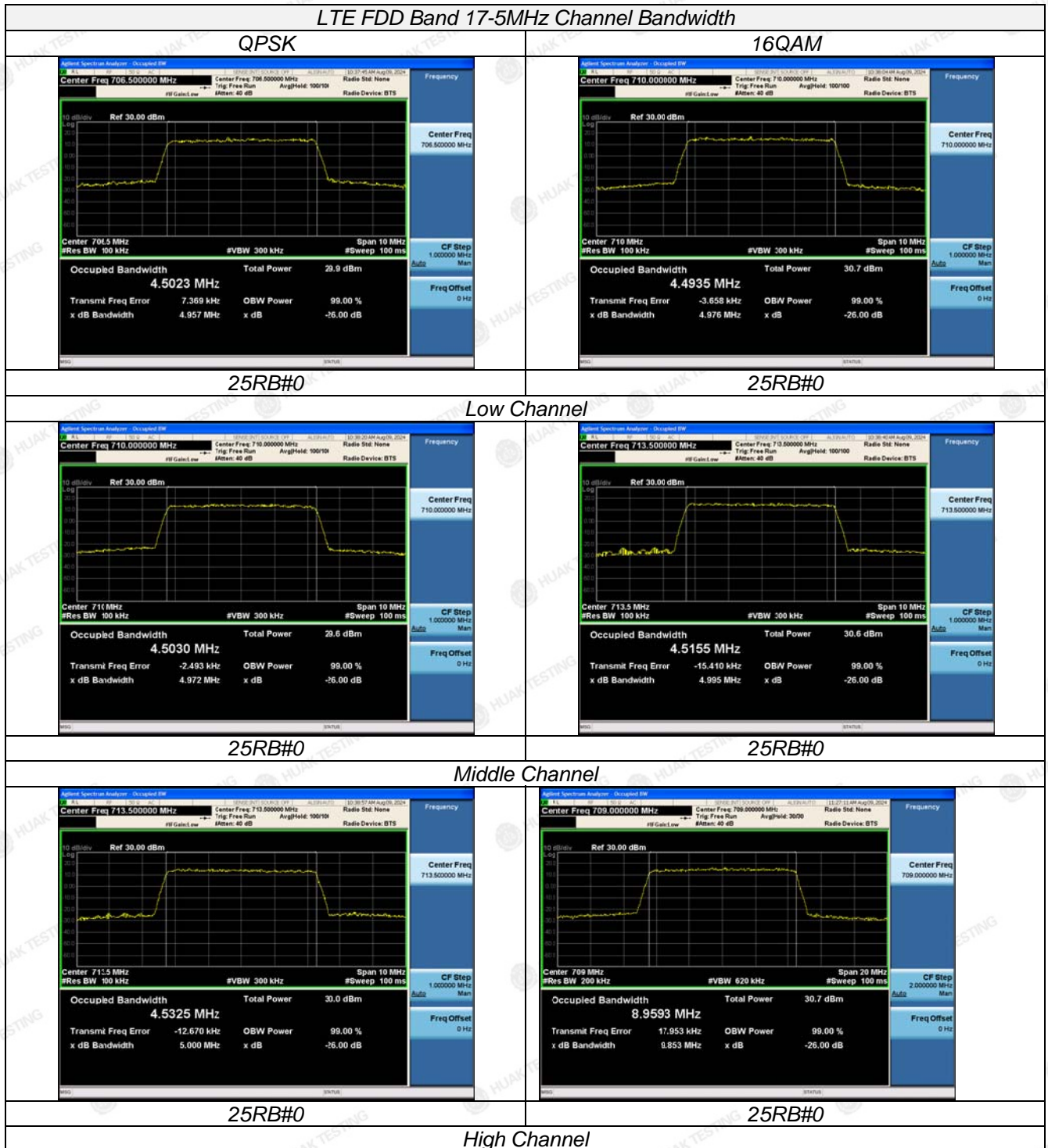

The results shown in this test report refer only to the sample(s) tested unless otherwise stated and the sample(s) are retained for 30 days only. The document is issued by HUAJ, this document cannot be reproduced except in full with our prior written permission. The more details and the authenticity of the report will be confirmed at <http://www.cer-mark.com>.

TEL : +86-755 2302 9901 FAX : +86-755 2302 9901 E-mail : service@cer-mark.com

Add: 1-2F., Building B2, Junfeng Zhongcheng Zhizao Innovation Park, Heping Community, Fuhai Street, Bao'an District, Shenzhen, Guangdong, China



The results shown in this test report refer only to the sample(s) tested unless otherwise stated and the sample(s) are retained for 30 days only. The document is issued by HUAJ, this document cannot be reproduced except in full with our prior written permission. The more details and the authenticity of the report will be confirmed at <http://www.cer-mark.com>.

TEL : +86-755 2302 9901 FAX : +86-755 2302 9901 E-mail : service@cer-mark.com

Add: 1-2F., Building B2, Junfeng Zhongcheng Zhizao Innovation Park, Heping Community, Fuhai Street, Bao'an District, Shenzhen, Guangdong, China



3.5 Band Edge compliance

LIMIT

that the power of any emission outside of the authorized operating frequency ranges must be attenuated below the transmitting power (P) by a factor of at least $43 + 10 \log (P)$ dB.

The specification that emissions shall be attenuated below the transmitter power (P) by at least $43 + 10 \log (P)$ dB, translates in the relevant power range (1 to 0.001 W) to -13 dBm. At 1 W the specified minimum attenuation becomes 43 dB and relative to a 30 dBm (1 W) carrier becomes a limit of -13 dBm. At 0.001 W (0 dBm) the minimum attenuation is 13 dB, which again yields a limit of -13 dBm. In this way a translation of the specification from relative to absolute terms is carried out.

TEST CONFIGURATION

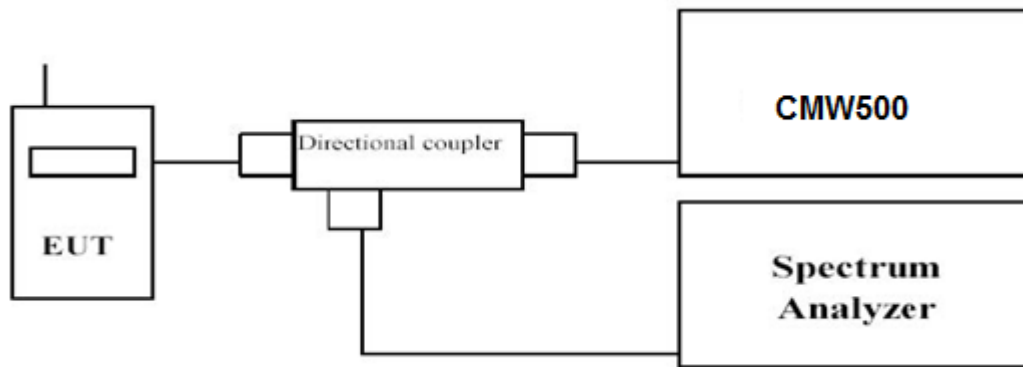

TEST PROCEDURE

1. The transmitter output port was connected to base station.
2. The RF output of EUT was connected to the power meter by RF cable and attenuator, the path loss was compensated to the results for each measurement.
3. Set EUT at maximum power through base station.
4. Select lowest and highest channels for each band and different modulation.
5. Measure Band edge using RMS (Average) detector by spectrum

TEST RESULTS

Remark:

1. We were tested all RB Configuration refer 3GPP TS136 521 for each Channel Bandwidth of LTE FDD Band 17; recorded worst case for each Channel Bandwidth of LTE FDD Band 17.



LTE FDD Band 17-5MHz Channel Bandwidth Band Edge Compliance

QPSK

16QAM

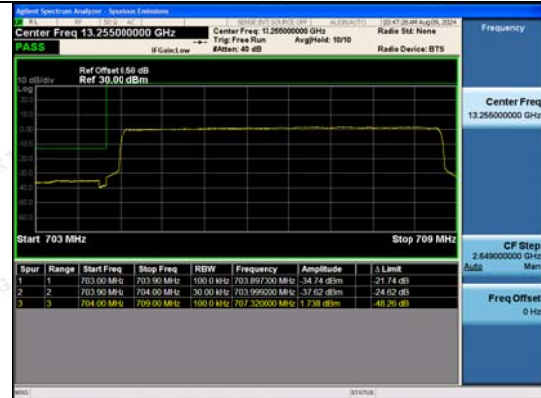
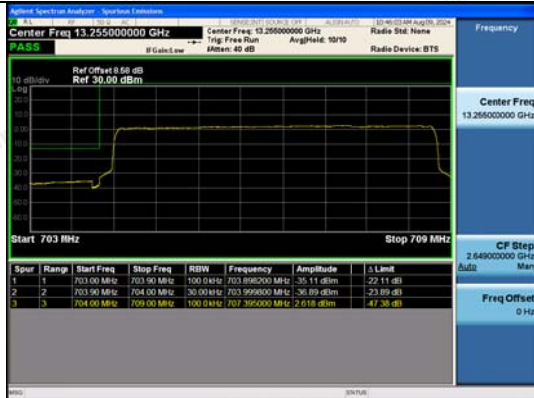

25RB#0

25RB#0

Low Channel

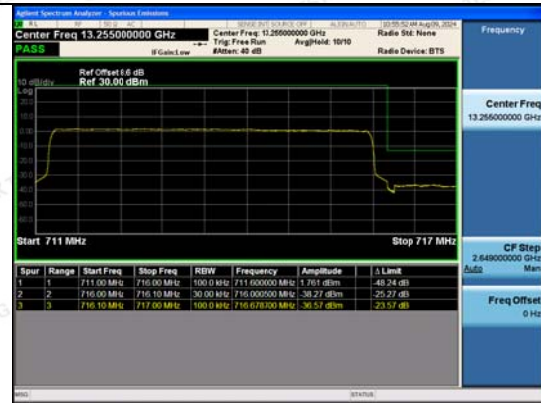
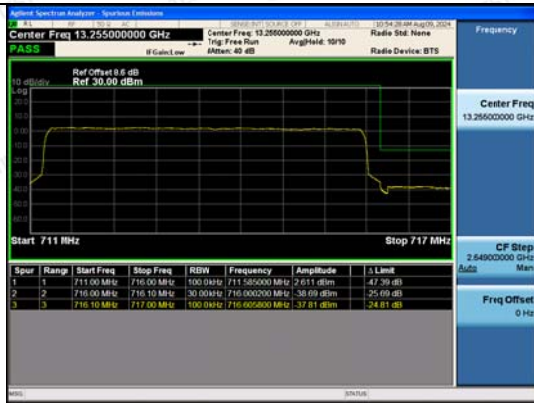

25RB#0

25RB#0

High Channel

The results shown in this test report refer only to the sample(s) tested unless otherwise stated and the sample(s) are retained for 30 days only. The document is issued by HUAJ, this document cannot be reproduced except in full with our prior written permission. The more details and the authenticity of the report will be confirmed at <http://www.cer-mark.com>.

TEL : +86-755 2302 9901 FAX : +86-755 2302 9901 E-mail : service@cer-mark.com

Add: 1-2F., Building B2, Junfeng Zhongcheng Zhizao Innovation Park, Heping Community, Fuhai Street, Bao'an District, Shenzhen, Guangdong, China

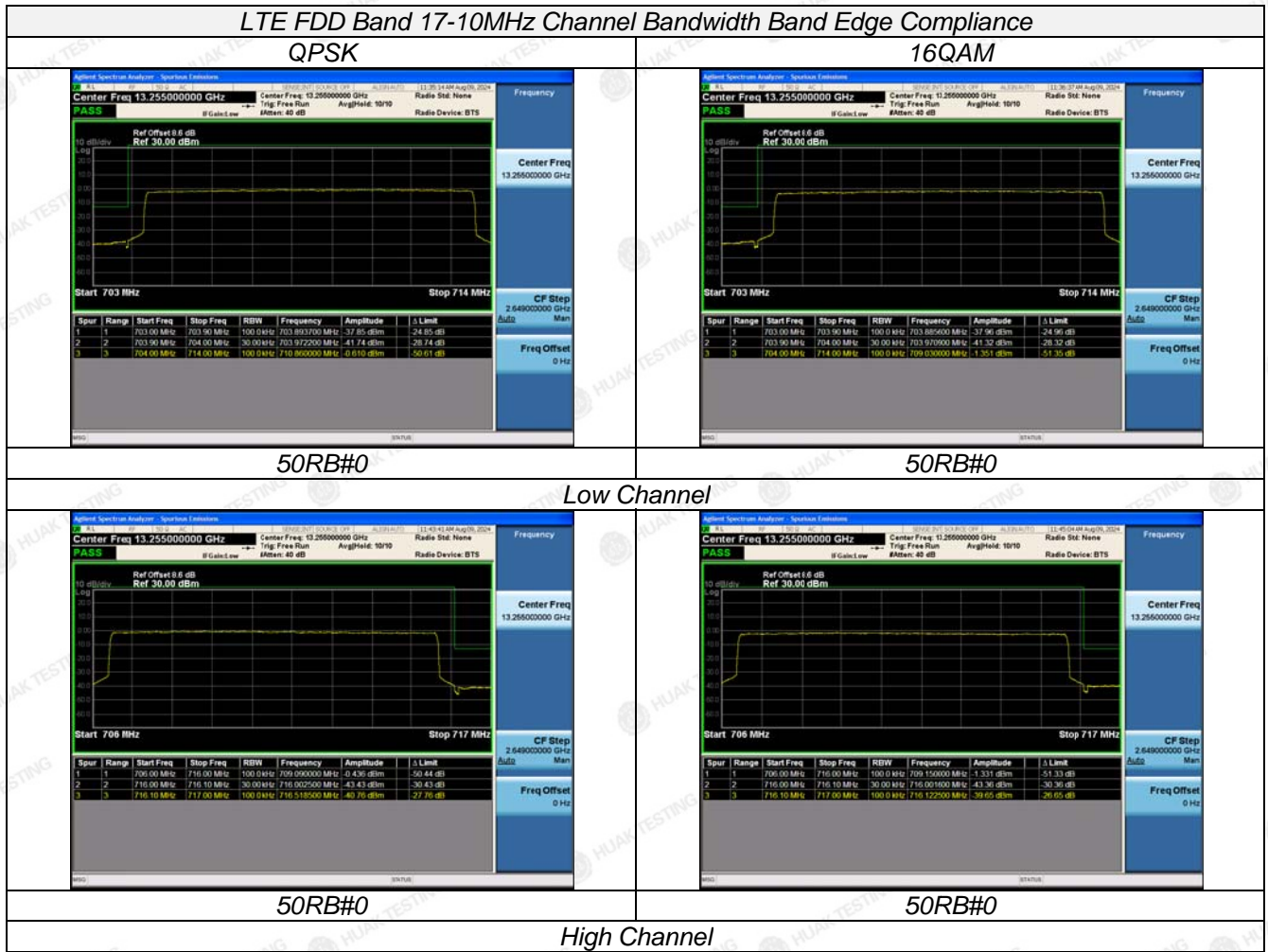

The results shown in this test report refer only to the sample(s) tested unless otherwise stated and the sample(s) are retained for 30 days only. The document is issued by HUAJ, this document cannot be reproduced except in full with our prior written permission. The more details and the authenticity of the report will be confirmed at <http://www.cer-mark.com>.

TEL : +86-755 2302 9901 FAX : +86-755 2302 9901 E-mail : service@cer-mark.com

Add: 1-2F., Building B2, Junfeng Zhongcheng Zhizao Innovation Park, Heping Community, Fuhai Street, Bao'an District, Shenzhen, Guangdong, China

3.6 Spurious Emission

LIMIT

that the power of any emission outside of the authorized operating frequency ranges must be attenuated below the transmitting power (P) by a factor of at least $43 + 10 \log (P)$ dB.

The specification that emissions shall be attenuated below the transmitter power (P) by at least $43 + 10 \log (P)$ dB, translates in the relevant power range (1 to 0.001 W) to -13 dBm. At 1 W the specified minimum attenuation becomes 43 dB and relative to a 30 dBm (1 W) carrier becomes a limit of -13 dBm. At 0.001 W (0 dBm) the minimum attenuation is 13 dB, which again yields a limit of -13 dBm. In this way a translation of the specification from relative to absolute terms is carried out.

TEST CONFIGURATION

Conducted Spurious Measurement:

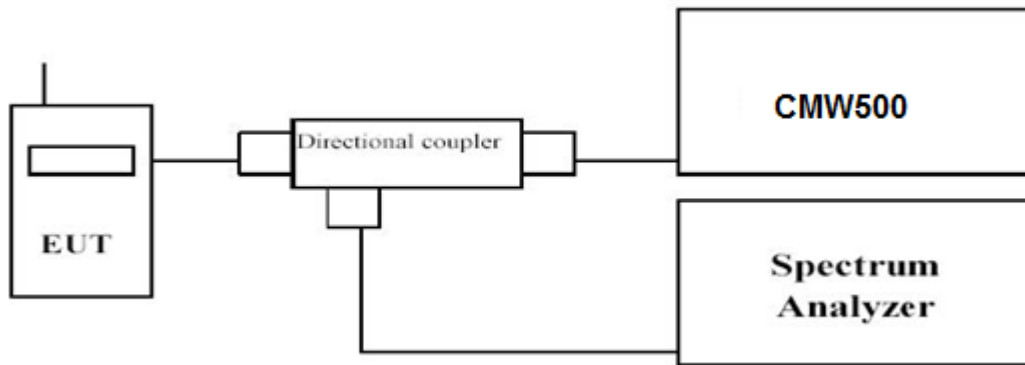

Radiated Spurious Measurement:

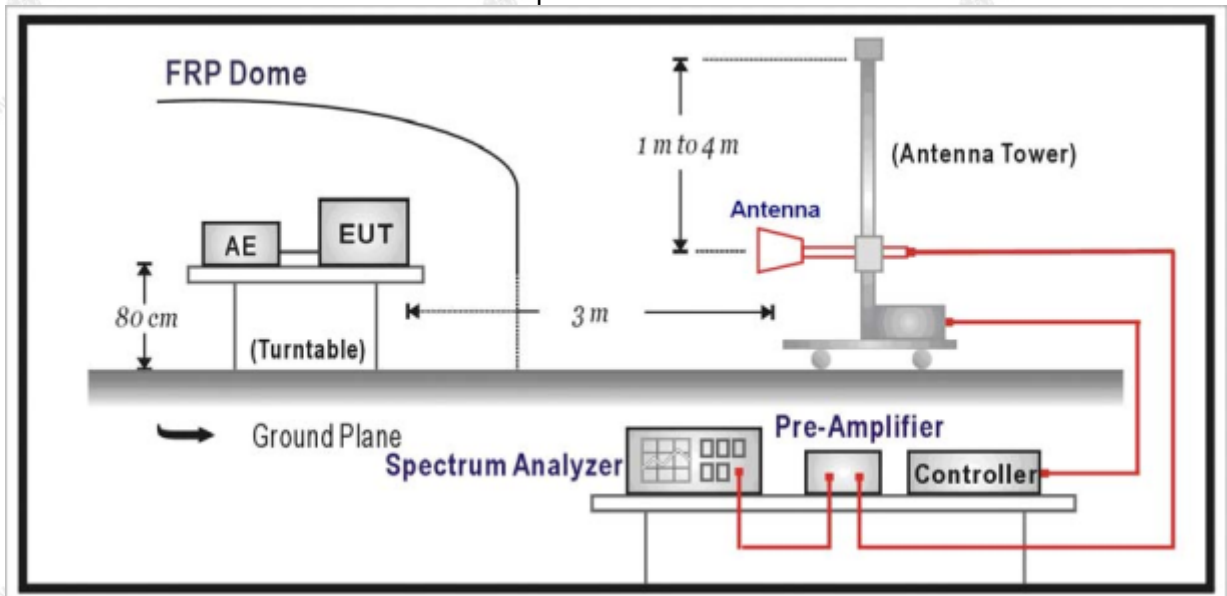

TEST PROCEDURE

The EUT was setup according to EIA/TIA 603D

Conducted Spurious Measurement:

- Place the EUT on a bench and set it in transmitting mode.
- Connect a low loss RF cable from the antenna port to a spectrum analyzer and CMW500 by a Directional Couple.
- EUT Communicate with CMW500, then select a channel for testing.
- Add a correction factor to the display of spectrum, and then test.



- e. The resolution bandwidth of the spectrum analyzer was set sufficient scans were taken to show the out of band Emission if any up to 10th harmonic.
- f. Please refer to following tables for test antenna conducted emissions.

g.

Working Frequency	Sub range (GHz)	RBW	VBW	Sweep time (s)
LTE FDD Band 17	0.03~26.5	1 MHz	3 MHz	Auto

Radiated Spurious Measurement:

- a. The EUT shall be placed at the specified height on a support, and in the position closest to normal use as declared by provider.
- b. The test antenna shall be oriented initially for vertical polarization and shall be chosen to correspond to the frequency of the transmitter
- c. The output of the test antenna shall be connected to the measuring receiver.
- d. The transmitter shall be switched on and the measuring receiver shall be tuned to the frequency of the transmitter under test.
- e. The test antenna shall be raised and lowered through the specified range of height until a maximum signal level is detected by the measuring receiver.
- f. The transmitter shall then be rotated through 360° in the horizontal plane, until the maximum signal level is detected by the measuring receiver.
- g. The test antenna shall be raised and lowered again through the specified range of height until a maximum signal level is detected by the measuring receiver.
- h. The maximum signal level detected by the measuring receiver shall be noted.
- i. The transmitter shall be replaced by a substitution antenna.
- j. The substitution antenna shall be orientated for vertical polarization and the length of the substitution antenna shall be adjusted to correspond to the frequency of the transmitter.
- k. The substitution antenna shall be connected to a calibrated signal generator.
- l. If necessary, the input attenuator setting of the measuring receiver shall be adjusted in order to increase the sensitivity of the measuring receiver.
- m. The test antenna shall be raised and lowered through the specified range of height to ensure that the maximum signal is received.
- n. The input signal to the substitution antenna shall be adjusted to the level that produces a level detected by the measuring receiver, that is equal to the level noted while the transmitter radiated power was measured, corrected for the change of input attenuator setting of the measuring receiver.
- o. The measurement shall be repeated with the test antenna and the substitution antenna orientated for horizontal polarization.
- p. The measure of the effective radiated power is the larger of the two levels recorded at the input to the substitution antenna, corrected for gain of the substitution antenna if necessary.
- q. The resolution bandwidth of the spectrum analyzer was set at 100 kHz for Part 22 and 1MHz for Part 24. The frequency range was checked up to 10th harmonic.
- r. Test site anechoic chamber refer to ANSI C63.

TEST RESULTS

Remark:

- 1. We were tested all RB Configuration refer 3GPP TS136 521 for each Channel Bandwidth of LTE FDD Band 17; recorded worst case for each Channel Bandwidth of LTE FDD Band 17.

Conducted Measurement:

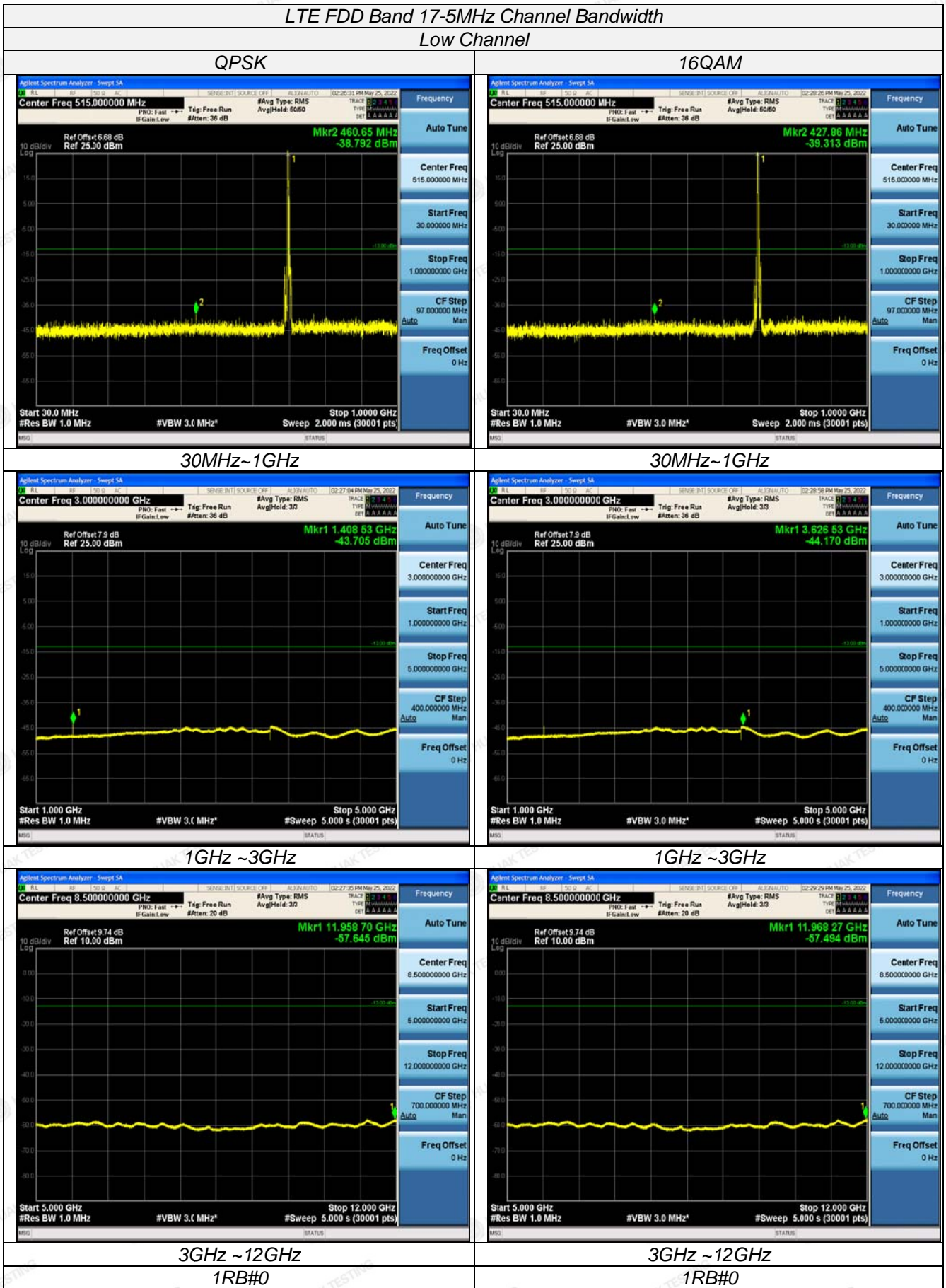

The results shown in this test report refer only to the sample(s) tested unless otherwise stated and the sample(s) are retained for 30 days only. The report is issued by HUAJ, this document cannot be reproduced except in full with our prior written permission. The more details and the authenticity of the report will be confirmed at <http://www.cer-mark.com>.

TEL : +86-755 2302 9901 FAX : +86-755 2302 9901 E-mail : service@cer-mark.com

Add: 1-2F., Building B2, Junfeng Zhongcheng Zhizao Innovation Park, Heping Community, Fuhai Street, Bao'an District, Shenzhen, Guangdong, China



LTE FDD Band 17-5MHz Channel Bandwidth

Middle Channel

QPSK

16QAM

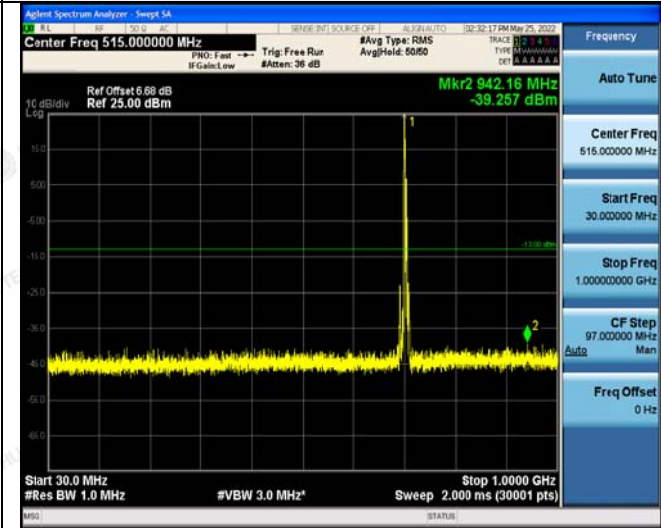
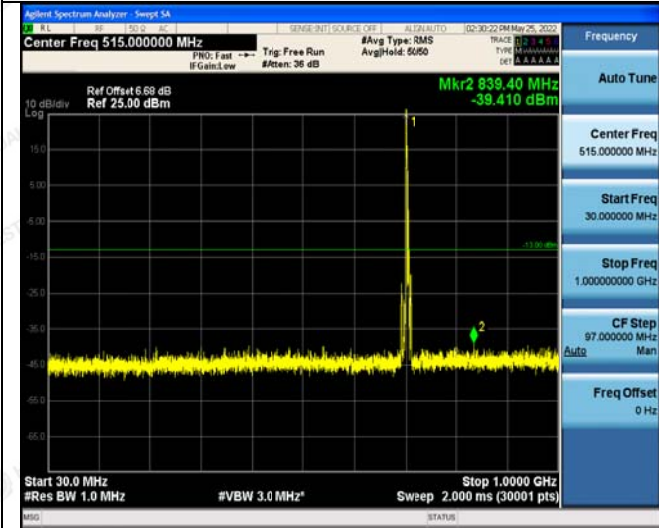

30MHz~1GHz

30MHz~1GHz



1GHz ~3GHz

1GHz ~3GHz



3GHz ~12GHz

3GHz ~12GHz

1RB#0

1RB#0

The results shown in this test report refer only to the sample(s) tested unless otherwise stated and the sample(s) are retained for 30 days only. The report is issued by HUAKE, this document cannot be reproduced except in full with our prior written permission. The more details and the authenticity of the report will be confirmed at <http://www.cer-mark.com>.

TEL : +86-755 2302 9901 FAX : +86-755 2302 9901 E-mail : service@cer-mark.com

Address: 1-2F., Building B2, Junfeng Zhongcheng Zhizao Innovation Park, Heping Community, Fuhai Street, Bao'an District, Shenzhen, Guangdong, China



LTE FDD Band 17-5MHz Channel Bandwidth

High Channel

QPSK

16QAM

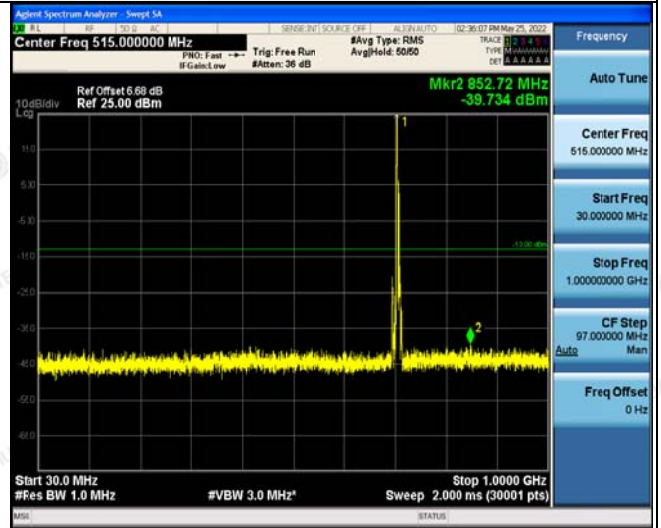
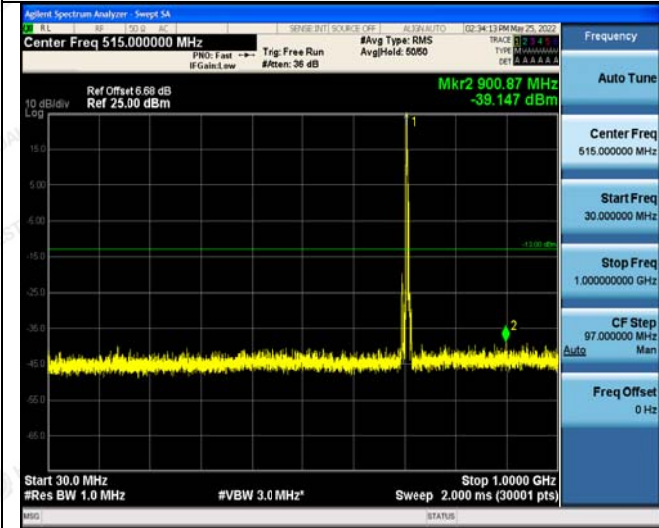

30MHz~1GHz

30MHz~1GHz



1GHz ~3GHz

1GHz ~3GHz



3GHz ~12GHz

3GHz ~12GHz

1RB#0

1RB#0

The results shown in this test report refer only to the sample(s) tested unless otherwise stated and the sample(s) are retained for 30 days only. The report is issued by HUAJ, this document cannot be reproduced except in full with our prior written permission. The more details and the authenticity of the report will be confirmed at <http://www.cer-mark.com>.

TEL : +86-755 2302 9901 FAX : +86-755 2302 9901 E-mail : service@cer-mark.com

Addr: 1-2F., Building B2, Junfeng Zhongcheng Zhizao Innovation Park, Heping Community, Fuhai Street, Bao'an District, Shenzhen, Guangdong, China



LTE FDD Band 17-10MHz Channel Bandwidth

Low Channel

QPSK

16QAM

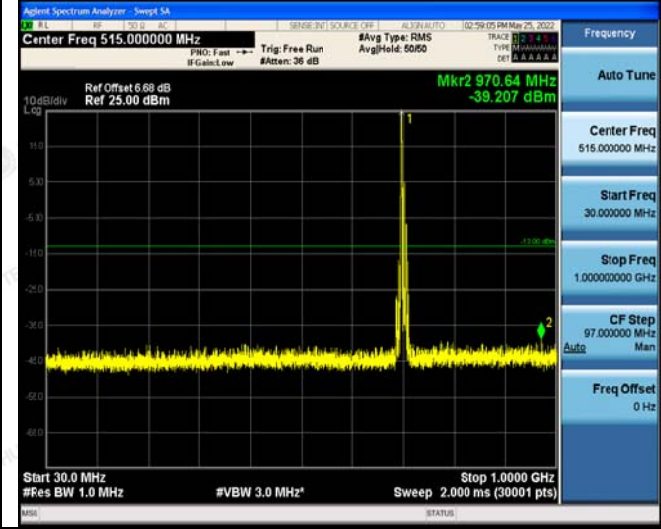
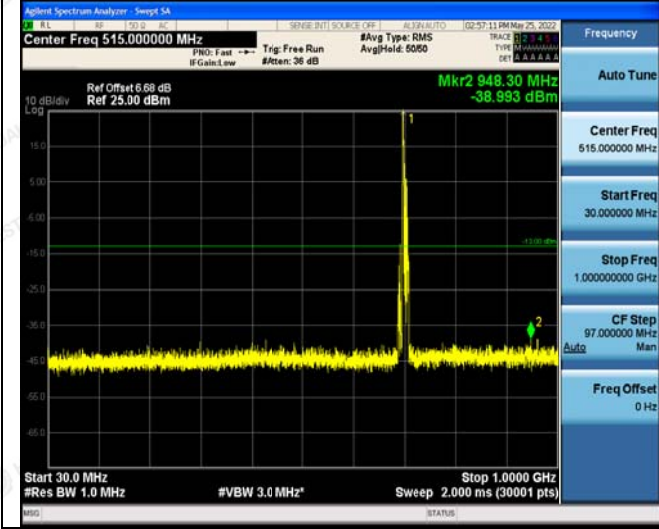

30MHz~1GHz

30MHz~1GHz



1GHz ~3GHz

1GHz ~3GHz



3GHz ~12GHz

3GHz ~12GHz

1RB#0

1RB#0

The results shown in this test report refer only to the sample(s) tested unless otherwise stated and the sample(s) are retained for 30 days only. The journal is issued by HUAK, this document cannot be reproduced except in full with our prior written permission. The more details and the authenticity of the report will be confirmed at <http://www.cer-mark.com>.

TEL : +86-755 2302 9901 FAX : +86-755 2302 9901 E-mail : service@cer-mark.com

Add: 1-2F., Building B2, Junfeng Zhongcheng Zhizao Innovation Park, Heping Community, Fuhai Street, Bao'an District, Shenzhen, Guangdong, China



LTE FDD Band 17-10MHz Channel Bandwidth
Middle Channel

QPSK

16QAM

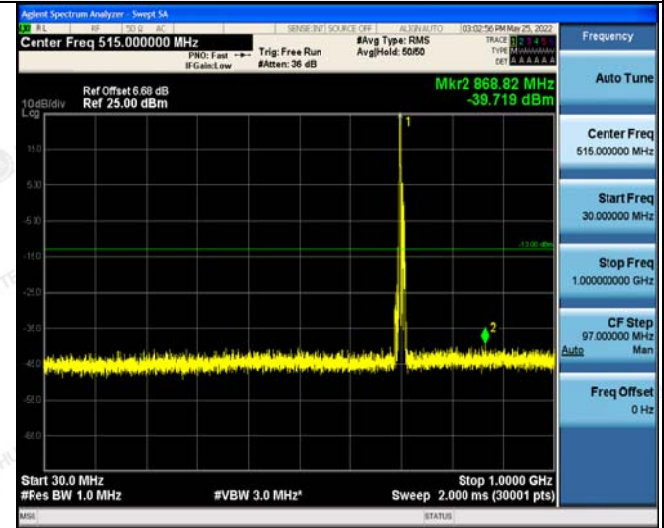
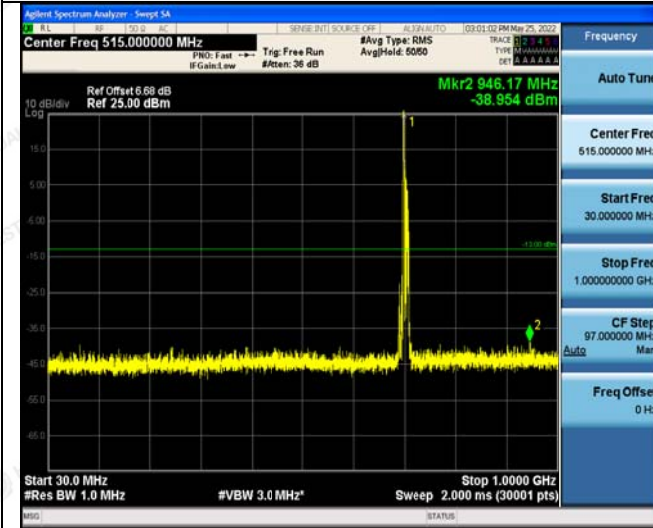

30MHz~1GHz

30MHz~1GHz



1GHz ~3GHz

1GHz ~3GHz



3GHz ~12GHz
1RB#0

3GHz ~12GHz
1RB#0

The results shown in this test report refer only to the sample(s) tested unless otherwise stated and the sample(s) are retained for 30 days only. The document is issued by HUAJ, this document cannot be reproduced except in full with our prior written permission. The more details and the authenticity of the report will be confirmed at <http://www.cer-mark.com>.

TEL : +86-755 2302 9901 FAX : +86-755 2302 9901 E-mail : service@cer-mark.com

Add: 1-2F., Building B2, Junfeng Zhongcheng Zhizao Innovation Park, Heping Community, Fuhai Street, Bao'an District, Shenzhen, Guangdong, China



LTE FDD Band 17-10MHz Channel Bandwidth
High Channel

QPSK

16QAM

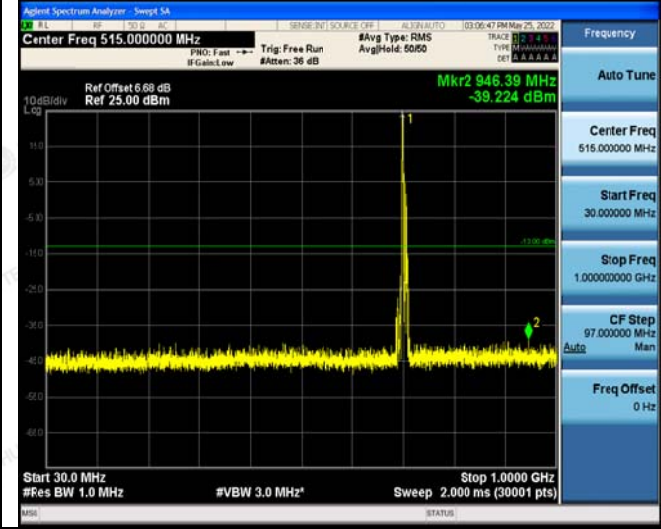
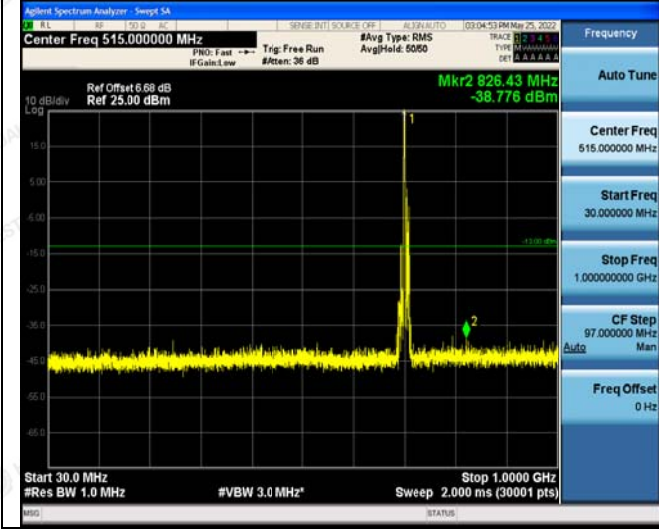

30MHz~1GHz

30MHz~1GHz



1GHz ~3GHz

1GHz ~3GHz



3GHz ~12GHz
1RB#0

3GHz ~12GHz
1RB#0

The results shown in this test report refer only to the sample(s) tested unless otherwise stated and the sample(s) are retained for 30 days only. The document is issued by HUAJ, this document cannot be reproduced except in full with our prior written permission. The more details and the authenticity of the report will be confirmed at <http://www.cer-mark.com>.

TEL : +86-755 2302 9901 FAX : +86-755 2302 9901 E-mail : service@cer-mark.com

Add: 1-2F., Building B2, Junfeng Zhongcheng Zhizao Innovation Park, Heping Community, Fuhai Street, Bao'an District, Shenzhen, Guangdong, China



Radiated Measurement:

Remark:

1. We were tested all RB Configuration refer 3GPP TS136 521 for each Channel Bandwidth of LTE FDD Band 17; recorded worst case for each Channel Bandwidth of LTE FDD Band 17.
2. $EIRP = P_{Mea}(dBm) - P_{cl}(dB) + G_a(dBi)$
3. We were not recorded other points as values lower than limits.
4. $Margin = Limit - EIRP$

LTE FDD Band 17_Channel Bandwidth 5MHz_QPSK_Low Channel

Frequency (MHz)	P _{Mea} (dBm)	P _{cl} (dB)	Diatance	G _a Antenna Gain(dB)	Peak EIRP (dBm)	Limit (dBm)	Margin (dB)	Polarization
1413.0	-45.08	2.86	3.00	7.25	-42.84	-13.00	29.84	H
2119.5	-45.23	2.94	3.00	9.53	-40.79	-13.00	27.79	H
1413.0	-46.58	2.86	3.00	7.25	-44.34	-13.00	31.34	V
2119.5	-49.92	2.94	3.00	9.53	-45.48	-13.00	32.48	V

LTE FDD Band 17_Channel Bandwidth 5MHz_QPSK_Middle Channel

Frequency (MHz)	P _{Mea} (dBm)	P _{cl} (dB)	Diatance	G _a Antenna Gain(dB)	EIRP (dBm)	Limit (dBm)	Margin (dB)	Polarization
1420.0	-47.05	2.86	3.00	7.25	-44.81	-13.00	31.81	H
2130.0	-45.34	2.94	3.00	9.53	-40.9	-13.00	27.9	H
1420.0	-45.53	2.86	3.00	7.25	-43.29	-13.00	30.29	V
2130.0	-49.21	2.94	3.00	9.53	-44.77	-13.00	31.77	V

LTE FDD Band 17_Channel Bandwidth 5MHz_QPSK_High Channel

Frequency (MHz)	P _{Mea} (dBm)	P _{cl} (dB)	Diatance	G _a Antenna Gain(dB)	EIRP (dBm)	Limit (dBm)	Margin (dB)	Polarization
1427.0	-47.37	2.86	3.00	7.82	-44.56	-13.00	31.56	H
2140.5	-43.94	2.94	3.00	9.35	-39.68	-13.00	26.68	H
1427.0	-46.34	2.86	3.00	7.82	-43.53	-13.00	30.53	V
2140.5	-48.55	2.94	3.00	9.35	-44.29	-13.00	31.29	V

LTE FDD Band 17_Channel Bandwidth 10MHz_QPSK_Low Channel

Frequency (MHz)	P _{Mea} (dBm)	P _{cl} (dB)	Diatance	G _a Antenna Gain(dB)	Peak EIRP (dBm)	Limit (dBm)	Margin (dB)	Polarization
1418.0	-46.48	2.86	3.00	7.25	-44.24	-13.00	31.24	H
2127.0	-45.87	2.94	3.00	9.53	-41.43	-13.00	28.43	H
1418.0	-46.05	2.86	3.00	7.25	-43.81	-13.00	30.81	V
2127.0	-47.33	2.94	3.00	9.53	-42.89	-13.00	29.89	V

LTE FDD Band 17_Channel Bandwidth 10MHz_QPSK_Middle Channel

Frequency (MHz)	P _{Mea} (dBm)	P _{cl} (dB)	Diatance	G _a Antenna Gain(dB)	EIRP (dBm)	Limit (dBm)	Margin (dB)	Polarization
1420.0	-47.21	2.86	3.00	7.25	-44.97	-13.00	31.97	H
2130.0	-45.13	2.94	3.00	9.53	-40.69	-13.00	27.69	H
1420.0	-46.15	2.86	3.00	7.25	-43.91	-13.00	30.91	V
2130.0	-48.14	2.94	3.00	9.53	-43.7	-13.00	30.7	V



LTE FDD Band 17_Channel Bandwidth 10MHz_QPSK_High Channel

Frequency (MHz)	P _{Mea} (dBm)	P _{cl} (dB)	Diatance	G _a Antenna Gain(dB)	EIRP (dBm)	Limit (dBm)	Margin (dB)	Polarization
1422.0	-45.49	2.86	3.00	7.82	-42.68	-13.00	29.68	H
2133.0	-44.73	2.94	3.00	9.35	-40.47	-13.00	27.47	H
1422.0	-45.49	2.86	3.00	7.82	-42.68	-13.00	29.68	V
2133.0	-49.56	2.94	3.00	9.35	-45.3	-13.00	32.3	V

LTE FDD Band 17_Channel Bandwidth 5MHz_16QAM_Low Channel

Frequency (MHz)	P _{Mea} (dBm)	P _{cl} (dB)	Diatance	G _a Antenna Gain(dB)	Peak EIRP (dBm)	Limit (dBm)	Margin (dB)	Polarization
1413.0	-45.62	2.86	3.00	7.25	-43.38	-13.00	30.38	H
2119.5	-45.61	2.94	3.00	9.53	-41.17	-13.00	28.17	H
1413.0	-47.71	2.86	3.00	7.25	-45.47	-13.00	32.47	V
2119.5	-48.46	2.94	3.00	9.53	-44.02	-13.00	31.02	V

LTE FDD Band 17_Channel Bandwidth 5MHz_16QAM_Middle Channel

Frequency (MHz)	P _{Mea} (dBm)	P _{cl} (dB)	Diatance	G _a Antenna Gain(dB)	EIRP (dBm)	Limit (dBm)	Margin (dB)	Polarization
1420.0	-45.27	2.86	3.00	7.25	-43.03	-13.00	30.03	H
2130.0	-43.75	2.94	3.00	9.53	-39.31	-13.00	26.31	H
1420.0	-45.98	2.86	3.00	7.25	-43.74	-13.00	30.74	V
2130.0	-49.66	2.94	3.00	9.53	-45.22	-13.00	32.22	V

LTE FDD Band 17_Channel Bandwidth 5MHz_16QAM_High Channel

Frequency (MHz)	P _{Mea} (dBm)	P _{cl} (dB)	Diatance	G _a Antenna Gain(dB)	EIRP (dBm)	Limit (dBm)	Margin (dB)	Polarization
1427.0	-45.96	2.86	3.00	7.82	-43.15	-13.00	30.15	H
2140.5	-45.2	2.94	3.00	9.35	-40.94	-13.00	27.94	H
1427.0	-46.68	2.86	3.00	7.82	-43.87	-13.00	30.87	V
2140.5	-48.39	2.94	3.00	9.35	-44.13	-13.00	31.13	V

LTE FDD Band 17_Channel Bandwidth 10MHz_16QAM_Low Channel

Frequency (MHz)	P _{Mea} (dBm)	P _{cl} (dB)	Diatance	G _a Antenna Gain(dB)	Peak EIRP (dBm)	Limit (dBm)	Margin (dB)	Polarization
1418.0	-46.75	2.86	3.00	7.25	-44.51	-13.00	31.51	H
2127.0	-45.11	2.94	3.00	9.53	-40.67	-13.00	27.67	H
1418.0	-46.99	2.86	3.00	7.25	-44.75	-13.00	31.75	V
2127.0	-49.58	2.94	3.00	9.53	-45.14	-13.00	32.14	V

LTE FDD Band 17_Channel Bandwidth 10MHz_16QAM_Middle Channel

Frequency (MHz)	P _{Mea} (dBm)	P _{cl} (dB)	Diatance	G _a Antenna Gain(dB)	EIRP (dBm)	Limit (dBm)	Margin (dB)	Polarization
1420.0	-46.71	2.86	3.00	7.25	-44.47	-13.00	31.47	H
2130.0	-44.74	2.94	3.00	9.53	-40.3	-13.00	27.3	H
1420.0	-45.55	2.86	3.00	7.25	-43.31	-13.00	30.31	V
2130.0	-49.43	2.94	3.00	9.53	-44.99	-13.00	31.99	V

The results shown in this test report refer only to the sample(s) tested unless otherwise stated and the sample(s) are retained for 30 days only. The document is issued by HUAKE, this document cannot be reproduced except in full with our prior written permission. The more details and the authenticity of the report will be confirmed at <http://www.cer-mark.com>.

TEL : +86-755 2302 9901 FAX : +86-755 2302 9901 E-mail : service@cer-mark.com

Add: 1-2F., Building B2, Junfeng Zhongcheng Zhizao Innovation Park, Heping Community, Fuhai Street, Bao'an District, Shenzhen, Guangdong, China



LTE FDD Band 17_Channel Bandwidth 10MHz_16QAM_High Channel

Frequency (MHz)	P _{Mea} (dBm)	P _{cl} (dB)	Diatance	G _a Antenna Gain(dB)	EIRP (dBm)	Limit (dBm)	Margin (dB)	Polarization
1422.0	-46.59	2.86	3.00	7.82	-43.78	-13.00	30.78	H
2133.0	-43.86	2.94	3.00	9.35	-39.6	-13.00	26.6	H
1422.0	-46.49	2.86	3.00	7.82	-43.68	-13.00	30.68	V
2133.0	-49.39	2.94	3.00	9.35	-45.13	-13.00	32.13	V

The results shown in this test report refer only to the sample(s) tested unless otherwise stated and the sample(s) are retained for 30 days only. The document is issued by HUAK, this document cannot be reproduced except in full with our prior written permission. The more details and the authenticity of the report will be confirmed at <http://www.cer-mark.com>.

TEL : +86-755 2302 9901 FAX : +86-755 2302 9901 E-mail : service@cer-mark.com

Add: 1-2F., Building B2, Junfeng Zhongcheng Zhizao Innovation Park, Heping Community, Fuhai Street, Bao'an District, Shenzhen, Guangdong, China

3.7 Frequency Stability under Temperature & Voltage Variations

LIMIT

the frequency stability shall be sufficient to ensure that the fundamental emissions stay within the authorized bands of operation and should not exceed 2.5ppm.

TEST CONFIGURATION

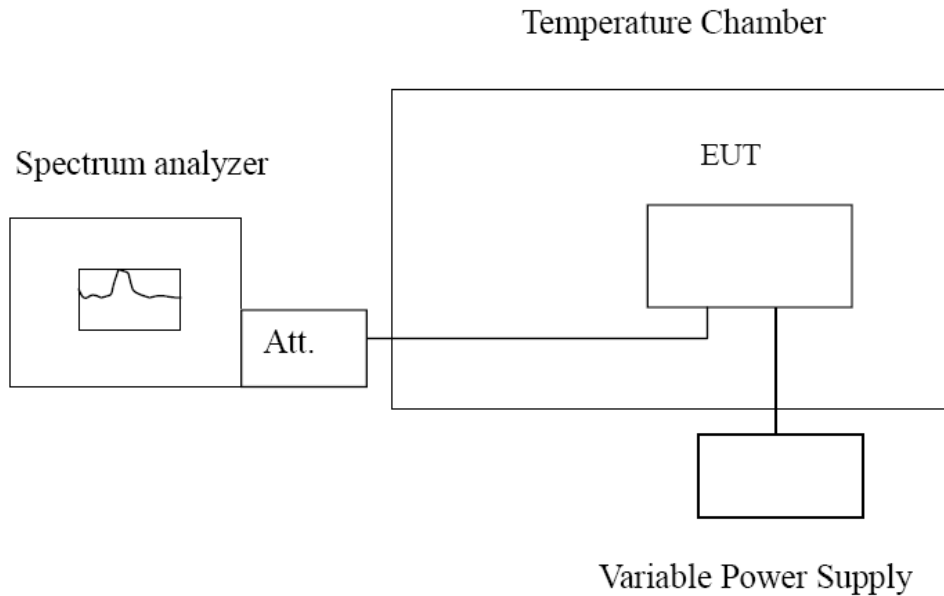

TEST PROCEDURE

The EUT was setup according to EIA/TIA 603D

Frequency Stability Under Temperature Variations:

In order to measure the carrier frequency under the condition of AFC lock, it is necessary to make measurements with the EUT in a "call mode". This is accomplished with the use of R&S CMW500 DIGITAL RADIO COMMUNICATION TESTER.

1. Measure the carrier frequency at room temperature.
2. Subject the EUT to overnight soak at -30°C.
3. With the EUT, powered via nominal voltage, connected to the CMW500 and in a simulated call on middle channel for LTE band 12, measure the carrier frequency. These measurements should be made within 2 minutes of Powering up the EUT, to prevent significant self-warming.
4. Repeat the above measurements at 10°C increments from -30°C to +50°C. Allow at least 1.5 hours at each temperature, unpowered, before making measurements.
5. Re-measure carrier frequency at room temperature with nominal voltage. Vary supply voltage from minimum voltage to maximum voltage, in 0.1Volt increments re-measuring carrier frequency at each voltage. Pause at nominal voltage for 1.5 hours unpowered, to allow any self-heating to stabilize, before continuing.
6. Subject the EUT to overnight soak at +50°C.
7. With the EUT, powered via nominal voltage, connected to the CMW500 and in a simulated call on the centre channel, measure the carrier frequency. These measurements should be made within 2 minutes of Powering up the EUT, to prevent significant self-warming.
8. Repeat the above measurements at 10 °C increments from +50°C to -30°C. Allow at least 1.5 hours at each temperature, unpowered, before making measurements
9. At all temperature levels hold the temperature to +/- 0.5°C during the measurement procedure.

Frequency Stability Under Voltage Variations:

Set chamber temperature to 20°C. Use a variable AC power supply / DC power source to power the EUT and set the voltage to rated voltage. Set the spectrum analyzer RBW low enough to obtain the desired frequency resolution and recorded the frequency.

Reduce the input voltage to specify extreme voltage variation ($\pm 15\%$) and endpoint, record the maximum frequency change.



TEST RESULTS

Remark:

1. We tested all RB Configuration refer 3GPP TS136 521 for each Channel Bandwidth of LTE FDD Band 17; recorded worst case.

LTE Band 17, 5MHz bandwidth (worst case of all bandwidths)

Frequency Error vs Voltage

Voltage (V)	Frequency error (Hz)		Frequency error (ppm)		Limit (ppm)
	QPSK	16QAM	QPSK	16QAM	
4.25	10.83	39.85	0.015254	0.056127	2.50
5.0	9.16	43.14	0.012901	0.060761	2.50
5.75	8.73	46.96	0.012296	0.066141	2.50

Frequency Error vs Temperature

Temperature (°C)	Frequency error (Hz)		Frequency error (ppm)		Limit (ppm)
	QPSK	16QAM	QPSK	16QAM	
-30°	11.39	49.85	0.016042	0.070211	2.50
-20°	13.13	-4.03	0.018493	-0.005676	2.50
-10°	16.09	-3.06	0.022662	-0.004310	2.50
0°	15.01	5.24	0.021141	0.007344	2.50
10°	18.02	3.81	0.025380	0.005340	2.50
20°	19.83	-2.26	0.027930	-0.003167	2.50
30°	29.35	-5.22	0.041338	-0.007316	2.50
40°	34.70	-11.22	0.048873	-0.015725	2.50
50°	35.79	-15.48	0.050408	-0.021696	2.50



4 TEST SETUP PHOTOS OF THE EUT

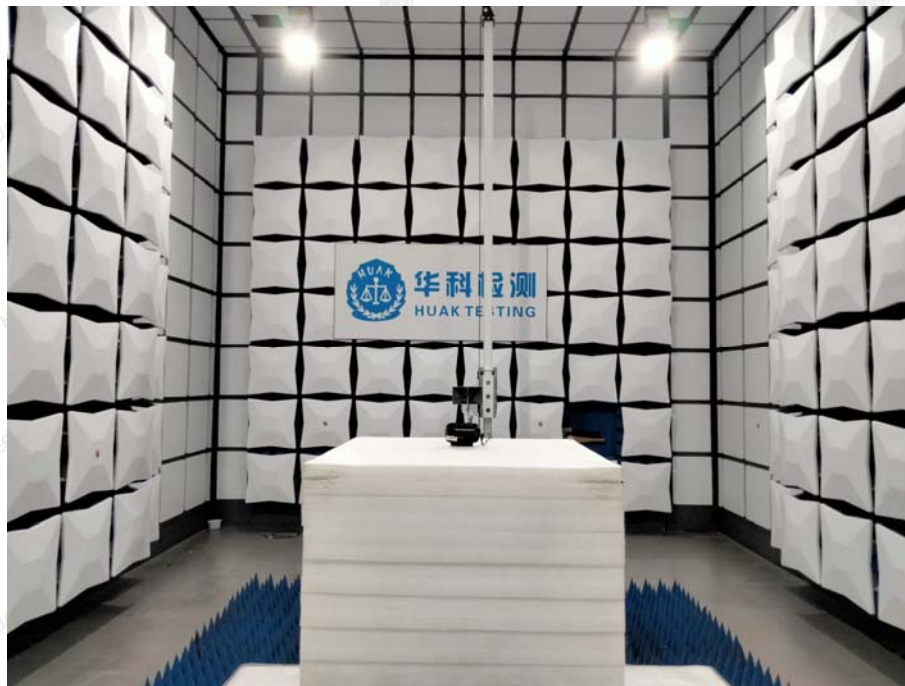
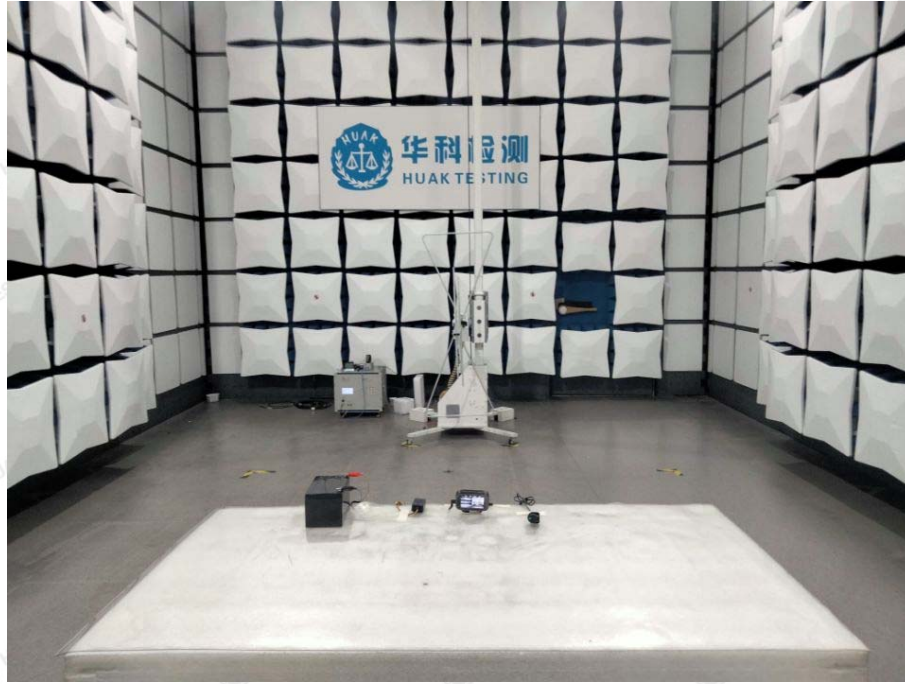

The results shown in this test report refer only to the sample(s) tested unless otherwise stated and the sample(s) are retained for 30 days only. The document is issued by HUAK, this document cannot be reproduced except in full with our prior written permission. The more details and the authenticity of the report will be confirmed at <http://www.cer-mark.com>.

TEL : +86-755 2302 9901 FAX : +86-755 2302 9901 E-mail : service@cer-mark.com

Address: 1-2F., Building B2, Junfeng Zhongcheng Zhizao Innovation Park, Heping Community, Fuhai Street, Bao'an District, Shenzhen, Guangdong, China



5 PHOTOS OF THE EUT

Reference to the report: ANNEX A of external photos and ANNEX B of internal photos.

.....**End of Report**.....

QUALIFICATION