



**FCC Test Report**

Report Reference No.....: **HK2407314284-5E**  
 FCC ID.....: **2BBBN-VISIONSYNC**  
 Compiled by  
 ( position+printed name+signature)..: **RF Department Manager Len Liao**  
 Supervised by  
 ( position+printed name+signature)..: **Technical Manager Sliver Wan**  
 Approved by  
 ( position+printed name+signature)..: **General Manager Jason Zhou**

*Len Liao*  
*Sliver Wan*  
*Jason Zhou*

Date of issue.....: **Aug. 15, 2024**  
**Testing Laboratory Name .....** **Shenzhen HUAK Testing Technology Co., Ltd.**  
 Address.....: **1-2/F., Building B2, Junfeng Zhongcheng Zhizao Innovation Park, Heping, Fuhai Street, Bao'an District, Shenzhen, Guangdong, China**

**Applicant's name.....** **Hangzhou Tanlink Technology Co.,Ltd.**  
 Address.....: **Room 701, South Building, Building 3, No.16, Longtan Road, Cangqian Street, Yuhang District, Hangzhou, Zhejiang, China**

**Test specification .....** :  
**Standard .....** : **FCC Part 27**

**Shenzhen HUAK Testing Technology Co., Ltd.All rights reserved.**  
 This publication may be reproduced in whole or in part for non-commercial purposes as long as the Shenzhen HUAK Testing Technology Co., Ltd.as copyright owner and source of the material. Shenzhen HUAK Testing Technology Co., Ltd.takes no responsibility for and will not assume liability for damages resulting from the reader's interpretation of the reproduced material due to its placement and context.

**Test item description .....** : **4G driving recorder**  
 Trade Mark ..... : **Redtiger**  
**Manufacturer .....** : **Hangzhou Tanlink Technology Co.,Ltd.**  
 Model/Type reference.....: **VisionSync 10**  
 Series Models ..... : **VisionSync 30, VisionSync 30 Pro, VisionSync 50, VisionSync 50 Pro, VisionSync 70, VisionSync 70 Pro, VisionSync 90, VisionSync 90 Pro, LinkStream 10, LinkStream 30**  
 Ratings.....: **DC 5V from Type-C**  
 Modulation ..... : **QPSK, 16QAM**  
 Hardware version ..... : **V2.0**  
 Software version ..... : **V2.0**  
 Frequency.....: **LTE Band 12**  
 Result.....: **PASS**

The results shown in this test report refer only to the sample(s) tested unless otherwise stated and the sample(s) are retained for 30 days only. The document is issued by HUAK, this document cannot be reproduced except in full with our prior written permission. The more details and the authenticity of the report will be confirmed at <http://www.cer-mark.com>.



# TEST REPORT

|                          |                        |               |
|--------------------------|------------------------|---------------|
| <b>Test Report No. :</b> | <b>HK2407314284-5E</b> | Aug. 15, 2024 |
|                          |                        | Date of issue |

Equipment under Test : 4G driving recorder

Model /Type : VisionSync 10

Series Models : VisionSync 30, VisionSync 30 Pro, VisionSync 50, VisionSync 50 Pro, VisionSync 70, VisionSync 70 Pro, VisionSync 90, VisionSync 90 Pro, LinkStream 10, LinkStream 30

**Applicant** : **Hangzhou Tanlink Technology Co.,Ltd.**

Address : Room 701, South Building, Building 3, No.16, Longtan Road, Cangqian Street, Yuhang District, Hangzhou, Zhejiang, China

**Manufacturer** : **Hangzhou Tanlink Technology Co.,Ltd.**

Address : Room 701, South Building, Building 3, No.16, Longtan Road, Cangqian Street, Yuhang District, Hangzhou, Zhejiang, China

|                    |             |
|--------------------|-------------|
| <b>Test result</b> | <b>Pass</b> |
|--------------------|-------------|

The test report merely corresponds to the test sample.  
It is not permitted to copy extracts of these test result without the written permission of the test laboratory.



## Contents

|          |  |           |
|----------|--|-----------|
| <b>1</b> | <b>SUMMARY</b>   | <b>4</b>  |
| 1.1      | Test Standards   | 4         |
| 1.2      | Test Description   | 4         |
| 1.3      | Information of The Test Laboratory                         | 5         |
| 1.4      | Statement of The Measurement Uncertainty                   | 5         |
| <b>2</b> | <b>GENERAL INFORMATION</b>                                 | <b>6</b>  |
| 2.1      | Environmental Conditions                                   | 6         |
| 2.2      | Description of Test Modes                                  | 6         |
| 2.3      | Equipments Used During The Test                            | 7         |
| 2.4      | Modifications  | 8         |
| <b>3</b> | <b>TEST CONDITIONS AND RESULTS</b>                         | <b>9</b>  |
| 3.1      | Output Power   | 9         |
| 3.2      | Peak-to-Average Ratio (PAR)                                | 14        |
| 3.3      | Occupied Bandwidth and Emission Bandwidth                  | 19        |
| 3.4      | Band Edge Compliance                                       | 24        |
| 3.5      | Spurious Emission  | 28        |
| 3.6      | Frequency Stability Under Temperature & Voltage Variations | 47        |
| <b>4</b> | <b>TEST SETUP PHOTOS OF THE EUT</b>                        | <b>49</b> |
| <b>5</b> | <b>PHOTOS OF THE EUT</b>                                   | <b>50</b> |



# 1 SUMMARY

## 1.1 Test Standards

The tests were performed according to following standards:

[FCC Part 27](#): MISCELLANEOUS WIRELESS COMMUNICATIONS SERVICES.

[TIA/EIA 603 D June 2010](#): Land Mobile FM or PM Communications Equipment Measurement and Performance Standards 47 CFR FCC Part 15 Subpart B: - Unintentional Radiators.

[FCC Part 2](#): FREQUENCY ALLOCATIONS AND RADIO TREATY MATTERS; GENERAL RULES AND REGULATIONS.

[KDB971168 D01](#): MEASUREMENT GUIDANCE FOR CERTIFICATION OF LICENSED DIGITAL TRANSMITTERS.

## 1.2 Test Description

| Test Item                              | FCC /IC Rule No.                 | Result |
|--|----------------------------------|--------|
| RF Output Power                        | Part 2.1046<br>Part 27.50(c)(10) | Pass   |
| Peak-to-Average Ratio                  | Part 2.1046                      | Pass   |
| 99% & -26 dB Occupied Bandwidth        | Part 2.1049                      | Pass   |
| Spurious Emissions at Antenna Terminal | Part 2.1051<br>Part 27.53(g)     | Pass   |
| Field Strength of Spurious Radiation   | Part 2.1053<br>Part 27.53(g)     | Pass   |
| Out of band emission, Band Edge        | Part 2.1051<br>Part 27.53(g)     | Pass   |
| Frequency stability                    | Part 2.1055<br>Part 27.54        | Pass   |

The results shown in this test report refer only to the sample(s) tested unless otherwise stated and the sample(s) are retained for 30 days only. The document is issued by HUAKE, this document cannot be reproduced except in full with our prior written permission. The more details and the authenticity of the report will be confirmed at <http://www.cer-mark.com>.



### 1.3 Information of The Test Laboratory

Shenzhen HUAKE Testing Technology Co., Ltd.  
Add.: 1-2/F., Building B2, Junfeng Zhongcheng Zhizao Innovation Park, Heping,  
Fuhai Street, Bao'an District, Shenzhen, Guangdong, China

Testing Laboratory Authorization:

A2LA Accreditation Code is 4781.01.  
FCC Designation Number is CN1229.  
Canada IC CAB identifier is CN0045.  
CNAS Registration Number is L9589.

### 1.4 Statement of The Measurement Uncertainty

The data and results referenced in this document are true and accurate. The reader is cautioned that there may be errors within the calibration limits of the equipment and facilities. The measurement uncertainty was calculated for all measurements listed in this test report acc. to CISPR 16 - 4 „Specification for radio disturbance and immunity measuring apparatus and methods – Part 4:Uncertainty in EMC Measurements“ and is documented in the Shenzhen HUAKE Testing Technology Co., Ltd.. quality system acc. to DIN EN ISO/IEC 17025. Furthermore, component and process variability of devices similar to that tested may result in additional deviation. The manufacturer has the sole responsibility of continued compliance of the device.

Hereafter the best measurement capability for Shenzhen HUAKE Testing Technology Co., Ltd.

| Test                  | Range      | Measurement Uncertainty | Notes |
|-----------------------|------------|-------------------------|-------|
| Radiated Emission     | 30~1000MHz | 4.10dB                  | (1)   |
| Radiated Emission     | Above 1GHz | 4.32dB                  | (1)   |
| Conducted Disturbance | 0.15~30MHz | 3.20dB                  | (1)   |

(1) This uncertainty represents an expanded uncertainty expressed at approximately the 95% confidence level using a coverage factor of k=2.



## 2 GENERAL INFORMATION

### 2.1 Environmental Conditions

During the measurement the environmental conditions were within the listed ranges:

|                     |         |
|---------------------|---------|
| Normal Temperature: | 25°C    |
| Relative Humidity:  | 55 %    |
| Air Pressure:       | 101 kPa |

### 2.2 Description of Test Modes

The EUT has been tested under typical operating condition. The CMW500 used to control the EUT staying in continuous transmitting and receiving mode for testing. Regards to the frequency band operation: the lowest, middle and highest frequency of channel were selected to perform the test, then shown on this report.

Note:

1. For the ERP/EIRP and radiated emission test, every axis (X, Y, Z) was verified, and show the worst resulton this report.
2. Test method and refer to 3GPP TS136521.



2.3 Equipments Used During The Test

| Item | Test Equipment                  | Manufacturer    | Model No.                   | Serial No. | Calibration Date | Calibration Due Date |
|------|---------------------------------|-----------------|-----------------------------|------------|------------------|----------------------|
| 1    | L.I.S.N.                        | R&S             | ENV216                      | HKE-002    | 2024/02/20       | 2025/02/19           |
| 2    | L.I.S.N.                        | R&S             | ENV216                      | HKE-059    | 2024/02/20       | 2025/02/19           |
| 3    | EMI Test Receiver               | R&S             | ESR                         | HKE-005    | 2024/02/20       | 2025/02/19           |
| 4    | Spectrum analyzer               | Agilent         | N9020A                      | HKE-048    | 2024/02/20       | 2025/02/19           |
| 5    | Spectrum analyzer               | R&S             | FSV3044                     | HKE-126    | 2024/02/20       | 2025/02/19           |
| 6    | Preamplifier                    | EMCI            | EMC051845<br>S              | HKE-006    | 2024/02/20       | 2025/02/19           |
| 7    | Preamplifier                    | Schwarzbeck     | BBV 9743                    | HKE-016    | 2024/02/20       | 2025/02/19           |
| 8    | Preamplifier                    | A.H. Systems    | SAS-574                     | HKE-182    | 2024/02/20       | 2025/02/19           |
| 9    | 6d Attenuator                   | Pasternack      | 6db                         | HKE-184    | 2024/02/20       | 2025/02/19           |
| 10   | EMI Test Receiver               | Rohde & Schwarz | ESR-7                       | HKE-010    | 2024/02/20       | 2025/02/19           |
| 11   | Broadband Antenna               | Schwarzbeck     | VULB9168                    | HKE-167    | 2024/02/21       | 2026/02/20           |
| 12   | Loop Antenna                    | COM-POWER       | AL-130R                     | HKE-014    | 2024/02/21       | 2026/02/20           |
| 13   | Horn Antenna                    | Schwarzbeck     | 9120D                       | HKE-013    | 2024/02/21       | 2026/02/20           |
| 14   | EMI Test Software               | Tonscend        | JS32-CE<br>2.5.0.6          | HKE-081    | /                | /                    |
| 15   | EMI Test Software               | Tonscend        | JS32-RE<br>5.0.0            | HKE-082    | /                | /                    |
| 16   | RF Automatic control unit       | Tonscend        | JS0806-1                    | HKE-096    | 2024/02/20       | 2025/02/19           |
| 17   | High pass filter unit           | Tonscend        | JS0806-F                    | HKE-055    | 2024/02/20       | 2025/02/19           |
| 18   | Wireless Communication Test Set | R&S             | CMU200                      | HKE-026    | 2024/02/20       | 2025/02/19           |
| 19   | Wireless Communication Test Set | R&S             | CMW500                      | HKE-027    | 2024/02/20       | 2025/02/19           |
| 20   | High-low temperature chamber    | Guangke         | HT-80L                      | HKE-118    | 2024/06/10       | 2025/06/09           |
| 21   | Temperature and humidity meter  | Boyang          | HTC-1                       | HKE-075    | 2024/06/10       | 2025/06/09           |
| 22   | RF Test Software                | Tonscend        | JS1120<br>Version<br>3.1.46 | HKE-183    | /                | /                    |

The results shown in this test report refer only to the sample(s) tested unless otherwise stated and the sample(s) are retained for 30 days only. The document is issued by HUAKE, this document cannot be reproduced except in full with our prior written permission. The more details and the authenticity of the report will be confirmed at <http://www.cer-mark.com>.

TEL : +86-755 2302 9901 FAX : +86-755 2302 9901 E-mail : [service@cer-mark.com](mailto:service@cer-mark.com)

Add: 1-2F., Building B2, Junfeng Zhongcheng Zhizao Innovation Park, Heping Community, Fuhai Street, Bao'an District, Shenzhen, Guangdong, China



## 2.4 Modifications

No modifications were implemented to meet testing criteria.



### 3 TEST CONDITIONS AND RESULTS

#### 3.1 Output Power

##### LIMIT

Portable stations (hand-held devices) in the 600 MHz uplink band and the 698-746 MHz band, and fixed and mobile stations in the 600 MHz uplink band are FCC limited to 3 watts ERP."IC limited to 5 watts ERP."

##### TEST CONFIGURATION

Conducted Power Measurement

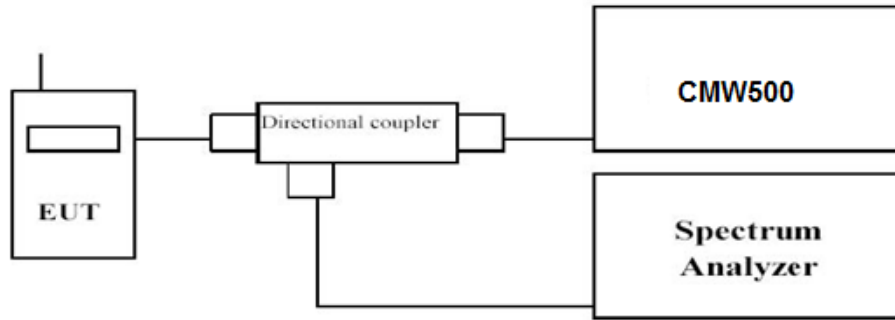

Radiated Power Measurement:

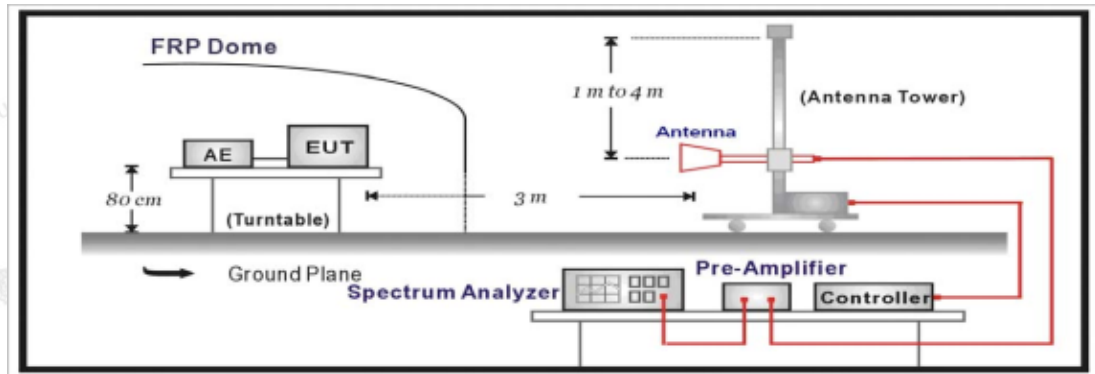

##### TEST PROCEDURE

The EUT was setup according to EIA/TIA 603D.

##### **Conducted Power Measurement:**

- Place the EUT on a bench and set it in transmitting mode.
- Connect a low loss RF cable from the antenna port to a spectrum analyzer and CMW500 by a Directional Couple.
- EUT Communicate with CMW500, then select a channel for testing.
- Add a correction factor to the display of spectrum, and then test.

##### **Radiated Power Measurement:**

- The EUT shall be placed at the specified height on a support, and in the position closest to normal use as declared by provider.
- The test antenna shall be oriented initially for vertical polarization and shall be chosen to correspond to the frequency of the transmitter.
- The output of the test antenna shall be connected to the measuring receiver.
- The transmitter shall be switched on and the measuring receiver shall be tuned to the frequency of the transmitter under test.
- The test antenna shall be raised and lowered through the specified range of height until a maximum signal level is detected by the measuring receiver.



- f. The transmitter shall then be rotated through 360° in the horizontal plane, until the maximum signal level is detected by the measuring receiver.
- g. The test antenna shall be raised and lowered again through the specified range of height until a maximum signal level is detected by the measuring receiver.
- h. The maximum signal level detected by the measuring receiver shall be noted.
- i. The transmitter shall be replaced by a substitution antenna.
- j. The substitution antenna shall be orientated for vertical polarization and the length of the substitution antenna shall be adjusted to correspond to the frequency of the transmitter.
- k. The substitution antenna shall be connected to a calibrated signal generator.
- l. If necessary, the input attenuator setting of the measuring receiver shall be adjusted in order to increase the sensitivity of the measuring receiver.
- m. The test antenna shall be raised and lowered through the specified range of height to ensure that the maximum signal is received.
- n. The input signal to the substitution antenna shall be adjusted to the level that produces a level detected by the measuring receiver, that is equal to the level noted while the transmitter radiated power was measured, corrected for the change of input attenuator setting of the measuring receiver.
- o. The measurement shall be repeated with the test antenna and the substitution antenna orientated for horizontal polarization.
- p. The measure of the effective radiated power is the larger of the two levels recorded at the input to the substitution antenna, corrected for gain of the substitution antenna if necessary.
- q. Test site anechoic chamber refer to ANSI C63.4.

**TEST RESULTS**

**Conducted Measurement:**

| LTE FDD Band 12      |                |                 |                     |       |
|----------------------|----------------|-----------------|---------------------|-------|
| TX Channel Bandwidth | RB Size/Offset | Frequency (MHz) | Average Power [dBm] |       |
|                      |                |                 | QPSK                | 16QAM |
| 1.4 MHz              | 1 RB low       | 699.7           | 23.00               | 22.18 |
|                      |                | 707.5           | 22.98               | 22.20 |
|                      |                | 715.3           | 23.08               | 22.23 |
|                      | 1 RB high      | 699.7           | 22.96               | 21.51 |
|                      |                | 707.5           | 22.91               | 21.49 |
|                      |                | 715.3           | 23.01               | 21.50 |
|                      | 50% RB mid     | 699.7           | 22.02               | 21.62 |
|                      |                | 707.5           | 23.02               | 22.58 |
|                      |                | 715.3           | 23.08               | 22.66 |
|                      | 100% RB        | 699.7           | 23.00               | 22.56 |
|                      |                | 707.5           | 23.05               | 21.95 |
|                      |                | 715.3           | 23.19               | 21.89 |
| 3 MHz                | 1 RB low       | 700.5           | 22.00               | 21.77 |
|                      |                | 707.5           | 22.08               | 21.48 |
|                      |                | 714.5           | 22.83               | 21.57 |
|                      | 1 RB high      | 700.5           | 22.91               | 21.61 |
|                      |                | 707.5           | 23.01               | 21.64 |
|                      |                | 714.5           | 22.09               | 21.24 |
|                      | 50% RB mid     | 700.5           | 22.09               | 21.23 |
|                      |                | 707.5           | 22.07               | 21.39 |
|                      |                | 714.5           | 22.19               | 21.11 |
|                      | 100% RB        | 700.5           | 23.06               | 21.56 |
|                      |                | 707.5           | 22.99               | 21.52 |
|                      |                | 714.5           | 23.04               | 21.53 |
| 5 MHz                | 1 RB low       | 701.5           | 21.93               | 21.49 |
|                      |                | 707.5           | 21.96               | 21.56 |
|                      |                | 713.5           | 23.11               | 21.37 |
|                      | 1 RB high      | 701.5           | 23.16               | 21.51 |
|                      |                | 707.5           | 23.12               | 21.54 |

The results shown in this test report refer only to the sample(s) tested unless otherwise stated and the sample(s) are retained for 30 days only. The document is issued by HUAKE, this document cannot be reproduced except in full with our prior written permission. The more details and the authenticity of the report will be confirmed at <http://www.cer-mark.com>.



|            |            |       |       |       |
|------------|------------|-------|-------|-------|
| 10 MHz     | 50% RB mid | 713.5 | 21.99 | 21.03 |
|            |            | 701.5 | 21.99 | 21.03 |
|            |            | 707.5 | 22.07 | 21.09 |
|            |            | 713.5 | 21.97 | 21.25 |
|            | 100% RB    | 701.5 | 23.21 | 22.12 |
|            |            | 707.5 | 23.10 | 22.20 |
|            |            | 713.5 | 23.14 | 22.15 |
|            | 1 RB low   | 704.0 | 22.05 | 20.98 |
|            |            | 707.5 | 23.15 | 21.84 |
|            |            | 711.0 | 23.14 | 21.92 |
|            | 1 RB high  | 704.0 | 23.27 | 21.94 |
|            |            | 707.5 | 22.10 | 21.24 |
| 711.0      |            | 22.08 | 21.20 |       |
| 50% RB mid | 704.0      | 22.16 | 21.22 |       |
|            | 707.5      | 22.13 | 21.21 |       |
|            | 711.0      | 23.00 | 22.70 |       |
| 100% RB    | 704.0      | 23.03 | 22.66 |       |
|            | 707.5      | 23.07 | 22.68 |       |
|            | 711.0      | 22.17 | 21.12 |       |

The results shown in this test report refer only to the sample(s) tested unless otherwise stated and the sample(s) are retained for 30 days only. The document is issued by HUAK, this document cannot be reproduced except in full with our prior written permission. The more details and the authenticity of the report will be confirmed at <http://www.cer-mark.com>.

TEL : +86-755 2302 9901 FAX : +86-755 2302 9901 E-mail : [service@cer-mark.com](mailto:service@cer-mark.com)

Add: 1-2F., Building B2, Junfeng Zhongcheng Zhizao Innovation Park, Heping Community, Fuhai Street, Bao'an District, Shenzhen, Guangdong, China



**Radiated Measurement:**

Remark:

1. We were tested all RB Configuration refer 3GPP TS136 521 for each Channel Bandwidth of LTE FDD Band 12; recorded worst case for each Channel Bandwidth of LTE FDD Band 12.
2.  $EIRP = P_{Mea}(dBm) - P_{cl}(dB) + P_{Ag}(dB) + G_a(dBi)$
3.  $ERP = EIRP - 2.15dBi$  as EIRP by subtracting the gain of the dipole.

**LTE FDD Band 12\_Channel Bandwidth 1.4MHz\_QPSK**

| Frequency (MHz) | P <sub>Mea</sub> (dBm) | P <sub>cl</sub> (dB) | G <sub>a</sub> Antenna Gain(dB) | Correction (dB) | P <sub>Ag</sub> (dB) | ERP (dBm) | Limit (dBm) | Polarization |
|-----------------|------------------------|----------------------|---------------------------------|-----------------|----------------------|-----------|-------------|--------------|
| 699.7           | -16.42                 | 2.38                 | 8.23                            | 2.15            | 36.7                 | 23.98     | 34.77       | V            |
| 707.5           | -17.38                 | 2.4                  | 8.29                            | 2.15            | 36.7                 | 23.06     | 34.77       | V            |
| 715.3           | -15.62                 | 2.43                 | 8.28                            | 2.15            | 36.7                 | 24.78     | 34.77       | V            |

**LTE FDD Band 12\_Channel Bandwidth 3MHz\_QPSK**

| Frequency (MHz) | P <sub>Mea</sub> (dBm) | P <sub>cl</sub> (dB) | G <sub>a</sub> Antenna Gain(dB) | Correction (dB) | P <sub>Ag</sub> (dB) | ERP (dBm) | Limit (dBm) | Polarization |
|-----------------|------------------------|----------------------|---------------------------------|-----------------|----------------------|-----------|-------------|--------------|
| 700.5           | -15.46                 | 2.38                 | 8.23                            | 2.15            | 36.7                 | 24.94     | 34.77       | V            |
| 707.5           | -15.85                 | 2.4                  | 8.29                            | 2.15            | 36.7                 | 24.59     | 34.77       | V            |
| 714.5           | -16.95                 | 2.43                 | 8.28                            | 2.15            | 36.7                 | 23.45     | 34.77       | V            |

**LTE FDD Band 12\_Channel Bandwidth 5MHz\_QPSK**

| Frequency (MHz) | P <sub>Mea</sub> (dBm) | P <sub>cl</sub> (dB) | G <sub>a</sub> Antenna Gain(dB) | Correction (dB) | P <sub>Ag</sub> (dB) | ERP (dBm) | Limit (dBm) | Polarization |
|-----------------|------------------------|----------------------|---------------------------------|-----------------|----------------------|-----------|-------------|--------------|
| 701.5           | -15.87                 | 2.38                 | 8.23                            | 2.15            | 36.7                 | 24.53     | 34.77       | V            |
| 707.5           | -15.78                 | 2.4                  | 8.29                            | 2.15            | 36.7                 | 24.66     | 34.77       | V            |
| 713.5           | -17.04                 | 2.43                 | 8.28                            | 2.15            | 36.7                 | 23.36     | 34.77       | V            |

**LTE FDD Band 12\_Channel Bandwidth 10MHz\_QPSK**

| Frequency (MHz) | P <sub>Mea</sub> (dBm) | P <sub>cl</sub> (dB) | G <sub>a</sub> Antenna Gain(dB) | Correction (dB) | P <sub>Ag</sub> (dB) | ERP (dBm) | Limit (dBm) | Polarization |
|-----------------|------------------------|----------------------|---------------------------------|-----------------|----------------------|-----------|-------------|--------------|
| 704.0           | -16.28                 | 2.38                 | 8.23                            | 2.15            | 36.7                 | 24.12     | 34.77       | V            |
| 707.5           | -16.96                 | 2.4                  | 8.29                            | 2.15            | 36.7                 | 23.48     | 34.77       | V            |
| 711.0           | -16.43                 | 2.43                 | 8.28                            | 2.15            | 36.7                 | 23.97     | 34.77       | V            |

**LTE FDD Band 12\_Channel Bandwidth 1.4MHz\_16QAM**

| Frequency (MHz) | P <sub>Mea</sub> (dBm) | P <sub>cl</sub> (dB) | G <sub>a</sub> Antenna Gain(dB) | Correction (dB) | P <sub>Ag</sub> (dB) | ERP (dBm) | Limit (dBm) | Polarization |
|-----------------|------------------------|----------------------|---------------------------------|-----------------|----------------------|-----------|-------------|--------------|
| 699.7           | -16.29                 | 2.38                 | 8.23                            | 2.15            | 36.7                 | 24.11     | 34.77       | V            |
| 707.5           | -16.97                 | 2.4                  | 8.29                            | 2.15            | 36.7                 | 23.47     | 34.77       | V            |
| 715.3           | -16.62                 | 2.43                 | 8.28                            | 2.15            | 36.7                 | 23.78     | 34.77       | V            |

**LTE FDD Band 12\_Channel Bandwidth 3MHz\_16QAM**

| Frequency (MHz) | P <sub>Mea</sub> (dBm) | P <sub>cl</sub> (dB) | G <sub>a</sub> Antenna Gain(dB) | Correction (dB) | P <sub>Ag</sub> (dB) | ERP (dBm) | Limit (dBm) | Polarization |
|-----------------|------------------------|----------------------|---------------------------------|-----------------|----------------------|-----------|-------------|--------------|
| 700.5           | -15.55                 | 2.38                 | 8.23                            | 2.15            | 36.7                 | 24.85     | 34.77       | V            |
| 707.5           | -16.97                 | 2.4                  | 8.29                            | 2.15            | 36.7                 | 23.47     | 34.77       | V            |
| 714.5           | -16.88                 | 2.43                 | 8.28                            | 2.15            | 36.7                 | 23.52     | 34.77       | V            |

The results shown in this test report refer only to the sample(s) tested unless otherwise stated and the sample(s) are retained for 30 days only. The document is issued by HUAKE, this document cannot be reproduced except in full with our prior written permission. The more details and the authenticity of the report will be confirmed at <http://www.cer-mark.com>.

TEL : +86-755 2302 9901 FAX : +86-755 2302 9901 E-mail : service@cer-mark.com

Add: 1-2F., Building B2, Junfeng Zhongcheng Zhizao Innovation Park, Heping Community, Fuhai Street, Bao'an District, Shenzhen, Guangdong, China



LTE FDD Band 12\_Channel Bandwidth 5MHz\_16QAM

| Frequency (MHz) | P <sub>Mea</sub> (dBm) | P <sub>cl</sub> (dB) | G <sub>a</sub> Antenna Gain(dB) | Correction (dB) | P <sub>Ag</sub> (dB) | ERP (dBm) | Limit (dBm) | Polarization |
|-----------------|------------------------|----------------------|---------------------------------|-----------------|----------------------|-----------|-------------|--------------|
| 701.5           | -16.29                 | 2.38                 | 8.23                            | 2.15            | 36.7                 | 24.11     | 34.77       | V            |
| 707.5           | -16.97                 | 2.4                  | 8.29                            | 2.15            | 36.7                 | 23.47     | 34.77       | V            |
| 713.5           | -15.79                 | 2.43                 | 8.28                            | 2.15            | 36.7                 | 24.61     | 34.77       | V            |

LTE FDD Band 12\_Channel Bandwidth 10MHz\_16QAM

| Frequency (MHz) | P <sub>Mea</sub> (dBm) | P <sub>cl</sub> (dB) | G <sub>a</sub> Antenna Gain(dB) | Correction (dB) | P <sub>Ag</sub> (dB) | ERP (dBm) | Limit (dBm) | Polarization |
|-----------------|------------------------|----------------------|---------------------------------|-----------------|----------------------|-----------|-------------|--------------|
| 704.0           | -16.85                 | 2.38                 | 8.23                            | 2.15            | 36.7                 | 23.55     | 34.77       | V            |
| 707.5           | -17.08                 | 2.4                  | 8.29                            | 2.15            | 36.7                 | 23.36     | 34.77       | V            |
| 711.0           | -16.98                 | 2.43                 | 8.28                            | 2.15            | 36.7                 | 23.42     | 34.77       | V            |

The results shown in this test report refer only to the sample(s) tested unless otherwise stated and the sample(s) are retained for 30 days only. The document is issued by HUAK, this document cannot be reproduced except in full with our prior written permission. The more details and the authenticity of the report will be confirmed at <http://www.cer-mark.com>.

TEL : +86-755 2302 9901 FAX : +86-755 2302 9901 E-mail : [service@cer-mark.com](mailto:service@cer-mark.com)

Add: 1-2F., Building B2, Junfeng Zhongcheng Zhizao Innovation Park, Heping Community, Fuhai Street, Bao'an District, Shenzhen, Guangdong, China



### 3.2 Peak-to-Average Ratio (PAR)

#### LIMIT

The Peak-to-Average Ratio (PAR) of the transmission may not exceed 13 dB.

#### TEST CONFIGURATION

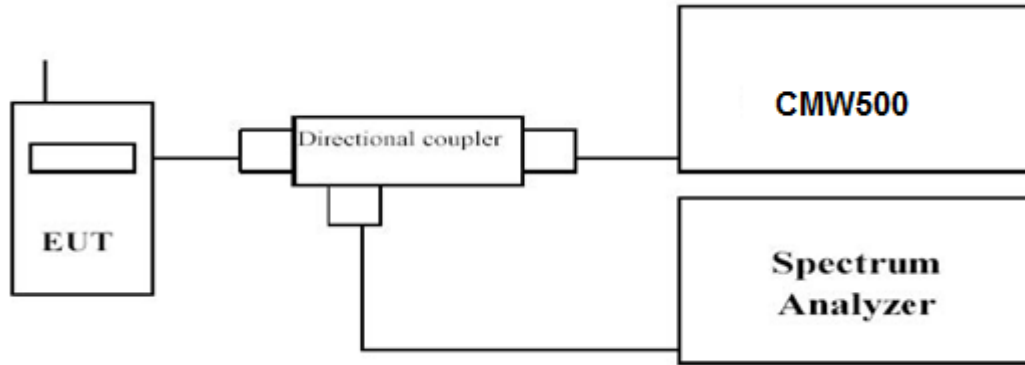

#### TEST PROCEDURE

1. Refer to instrument's analyzer instruction manual for details on how to use the power statistics/CCDF function;
2. Set resolution/measurement bandwidth  $\geq$  signal's occupied bandwidth;
3. Set the number of counts to a value that stabilizes the measured CCDF curve;
4. Set the measurement interval as follows:
  - 1). for continuous transmissions, set to 1 ms;
  - 2). for burst transmissions, employ an external trigger that is synchronized with the EUT burst timing sequence, or use the internal burst trigger with a trigger level that allows the burst to stabilize and set the measurement interval to a time that is less than or equal to the burst duration.
5. Record the maximum PAPR level associated with a probability of 0.1%.

#### TEST RESULTS

Remark:

1. We were tested all RB Configuration refer 3GPP TS136 521 for each Channel Bandwidth of LTE FDD Band 12; recorded worst case for each Channel Bandwidth of LTE FDD Band 12.

| LTE FDD Band 12      |                 |                |           |       |
|----------------------|-----------------|----------------|-----------|-------|
| TX Channel Bandwidth | Frequency (MHz) | RB Size/Offset | PAPR (dB) |       |
|                      |                 |                | QPSK      | 16QAM |
| 1.4 MHz              | 699.7           | 1RB#0          | 5.63      | 6.36  |
|                      | 707.5           |                | 5.29      | 6.22  |
|                      | 715.3           |                | 5.41      | 6.24  |
| 3 MHz                | 700.5           | 1RB#0          | 5.73      | 6.66  |
|                      | 707.5           |                | 5.48      | 6.50  |
|                      | 714.5           |                | 5.46      | 6.20  |
| 5 MHz                | 701.5           | 1RB#0          | 5.85      | 6.26  |
|                      | 707.5           |                | 5.64      | 6.21  |
|                      | 713.5           |                | 8.42      | 10.31 |
| 10 MHz               | 704.0           | 1RB#0          | 5.66      | 6.76  |
|                      | 707.5           |                | 5.72      | 6.63  |
|                      | 711.0           |                | 5.33      | 6.18  |

The results shown in this test report refer only to the sample(s) tested unless otherwise stated and the sample(s) are retained for 30 days only. The document is issued by HUAK, this document cannot be reproduced except in full with our prior written permission. The more details and the authenticity of the report will be confirmed at <http://www.cer-mark.com>.



LTE FDD Band 12-1.4MHz Channel Bandwidth PAPR

QPSK

16QAM

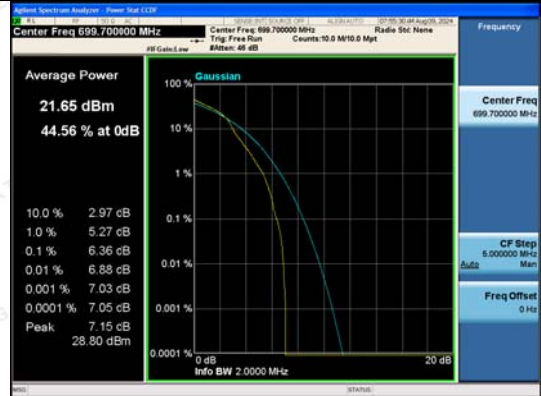

1RB#0

1RB#0

Low Channel



1RB#0

1RB#0

Middle Channel



1RB#0

1RB#0

High Channel

The results shown in this test report refer only to the sample(s) tested unless otherwise stated and the sample(s) are retained for 30 days only. The document is issued by HUAJ, this document cannot be reproduced except in full with our prior written permission. The more details and the authenticity of the report will be confirmed at <http://www.cer-mark.com>.

TEL : +86-755 2302 9901 FAX : +86-755 2302 9901 E-mail : service@cer-mark.com

Add: 1-2F., Building B2, Junfeng Zhongcheng Zhizao Innovation Park, Heping Community, Fuhai Street, Bao'an District, Shenzhen, Guangdong, China



LTE FDD Band 12-3MHz Channel Bandwidth PAPR

QPSK

16QAM

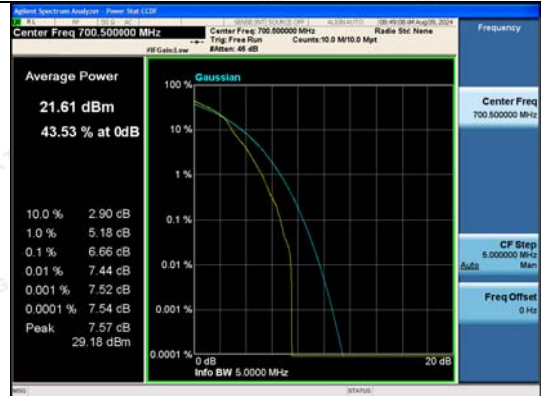

1RB#0

1RB#0

Low Channel



1RB#0

1RB#0

Middle Channel

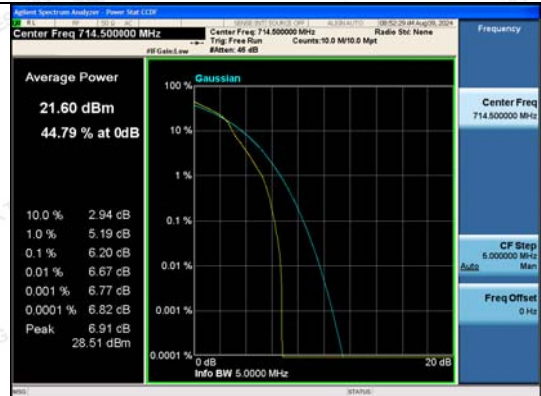

1RB#0

1RB#0

High Channel

The results shown in this test report refer only to the sample(s) tested unless otherwise stated and the sample(s) are retained for 30 days only. The document is issued by HUAJ, this document cannot be reproduced except in full with our prior written permission. The more details and the authenticity of the report will be confirmed at <http://www.cer-mark.com>.

TEL : +86-755 2302 9901 FAX : +86-755 2302 9901 E-mail : service@cer-mark.com

Add: 1-2F., Building B2, Junfeng Zhongcheng Zhizao Innovation Park, Heping Community, Fuhai Street, Bao'an District, Shenzhen, Guangdong, China



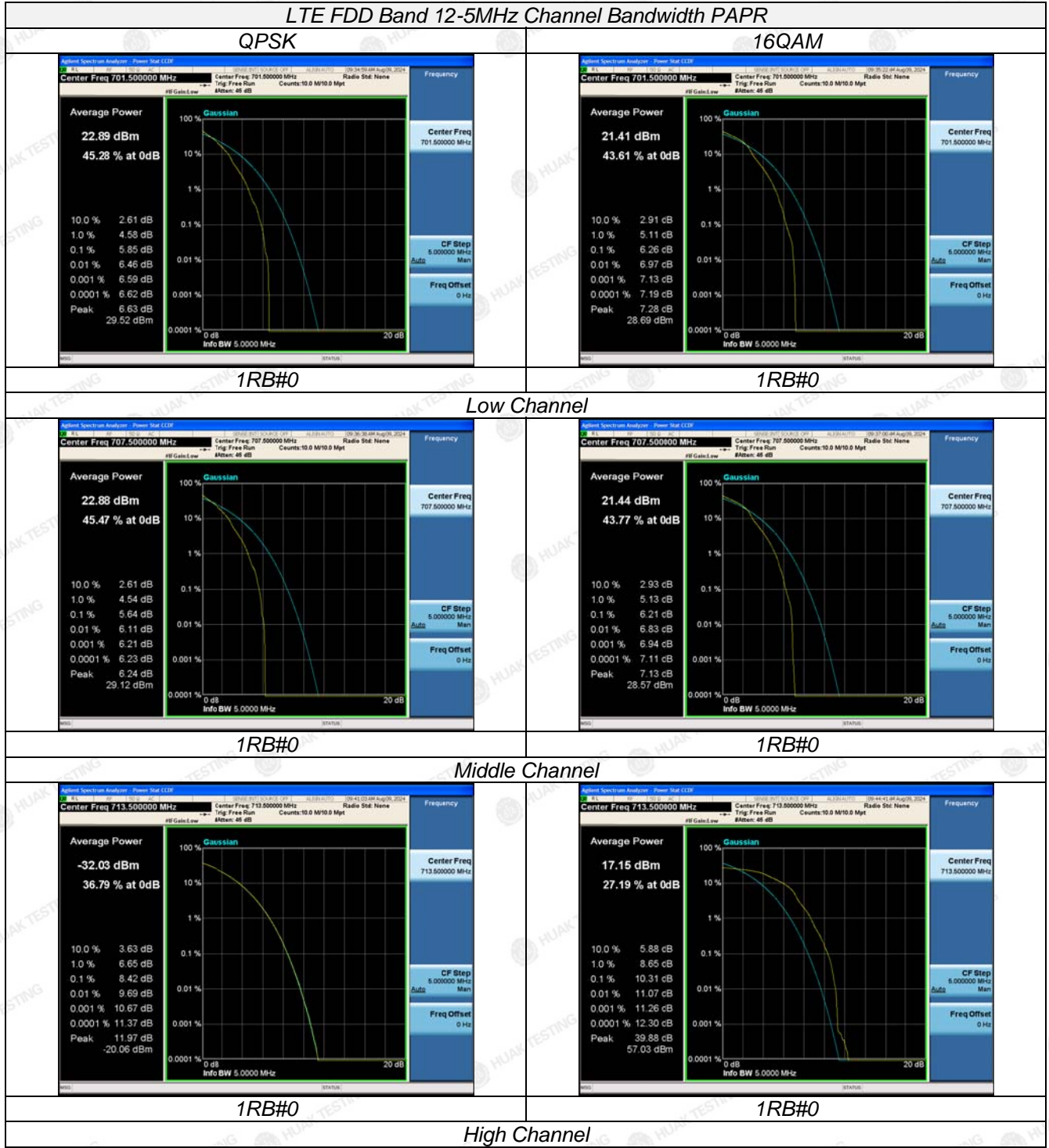

The results shown in this test report refer only to the sample(s) tested unless otherwise stated and the sample(s) are retained for 30 days only. The document is issued by HUAJ, this document cannot be reproduced except in full with our prior written permission. The more details and the authenticity of the report will be confirmed at <http://www.cer-mark.com>.

TEL : +86-755 2302 9901 FAX : +86-755 2302 9901 E-mail : service@cer-mark.com

Add: 1-2F., Building B2, Junfeng Zhongcheng Zhizao Innovation Park, Heping Community, Fuhai Street, Bao'an District, Shenzhen, Guangdong, China



LTE FDD Band 12-10MHz Channel Bandwidth PAPR

QPSK

16QAM



1RB#0

1RB#0

Low Channel



1RB#0

1RB#0

Middle Channel

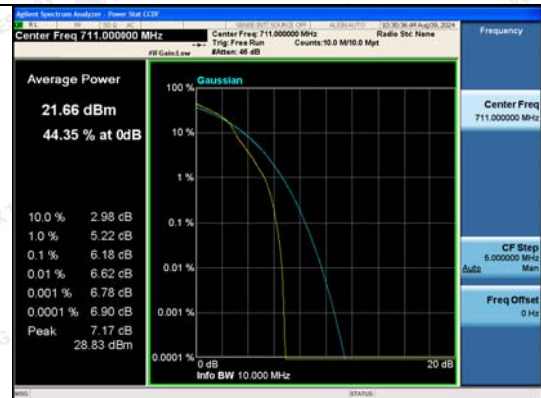

1RB#0

1RB#0

High Channel

The results shown in this test report refer only to the sample(s) tested unless otherwise stated and the sample(s) are retained for 30 days only. The document is issued by HUAJ, this document cannot be reproduced except in full with our prior written permission. The more details and the authenticity of the report will be confirmed at <http://www.cer-mark.com>.

TEL : +86-755 2302 9901 FAX : +86-755 2302 9901 E-mail : service@cer-mark.com

Add: 1-2F., Building B2, Junfeng Zhongcheng Zhizao Innovation Park, Heping Community, Fuhai Street, Bao'an District, Shenzhen, Guangdong, China

**3.3 Occupied Bandwidth and Emission Bandwidth**

**LIMIT**

N/A

**TEST CONFIGURATION**

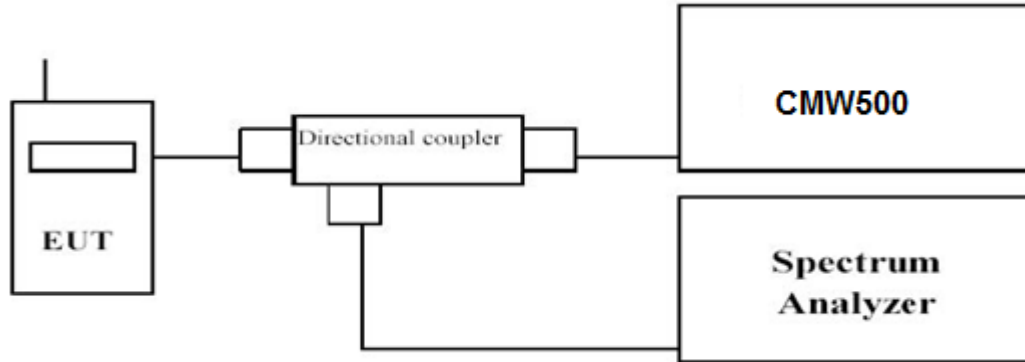

**TEST PROCEDURE**

The transmitter output was connected to a calibrated coaxial cable and coupler, the other end of which was connected to a spectrum analyzer. The occupied bandwidth was measured with the spectrum analyzer at low, middle and high channel in each band. The -26dBc Emission bandwidth was also measured and recorded. Set RBW was set to about 1% of emission BW, VBW≥3 times RBW. -26dBc display line was placed on the screen (or 99% bandwidth), the occupied bandwidth is the delta frequency between the two points where the display line intersects the signal trace.

**TEST RESULTS**

Remark:

1. We were tested all RB Configuration refer 3GPP TS136 521 for each Channel Bandwidth of LTE FDD Band 12; recorded worst case for each Channel Bandwidth of LTE FDD Band 12.

| LTE FDD Band 12      |                             |                 |                                 |       |                              |        |
|----------------------|-----------------------------|-----------------|---------------------------------|-------|------------------------------|--------|
| TX Channel Bandwidth | RB Size/Offset              | Frequency (MHz) | -26dBc Emission bandwidth (MHz) |       | 99% Occupied bandwidth (MHz) |        |
|                      |                             |                 | QPSK                            | 16QAM | QPSK                         | 16QAM  |
| 1.4 MHz              | 6RB#0                       | 699.7           | 1.244                           | 1.253 | 1.0924                       | 1.0992 |
|                      |                             | 707.5           | 1.247                           | 1.249 | 1.0871                       | 1.1013 |
|                      |                             | 715.3           | 1.246                           | 1.249 | 1.0933                       | 1.0970 |
| 3 MHz                | 15RB#0                      | 700.5           | 3.054                           | 3.016 | 2.7162                       | 2.6977 |
|                      |                             | 707.5           | 3.050                           | 3.013 | 2.7025                       | 2.6939 |
|                      |                             | 714.5           | 3.014                           | 3.046 | 2.7019                       | 2.7057 |
| 5 MHz                | 25RB#0                      | 701.5           | 4.981                           | 4.953 | 4.5140                       | 4.5117 |
|                      |                             | 707.5           | 4.970                           | 4.954 | 4.5058                       | 4.5012 |
|                      |                             | 713.5           | 4.977                           | 4.989 | 4.5068                       | 4.5202 |
| 10 MHz               | QPSK:50RB#0<br>16QAM:12RB#0 | 704.0           | 9.884                           | 9.879 | 9.0079                       | 9.0189 |
|                      |                             | 707.5           | 9.875                           | 9.873 | 8.9754                       | 8.9684 |
|                      |                             | 711.0           | 9.791                           | 9.956 | 8.9534                       | 8.9885 |

The results shown in this test report refer only to the sample(s) tested unless otherwise stated and the sample(s) are retained for 30 days only. The document is issued by HUAKE, this document cannot be reproduced except in full with our prior written permission. The more details and the authenticity of the report will be confirmed at <http://www.cer-mark.com>.

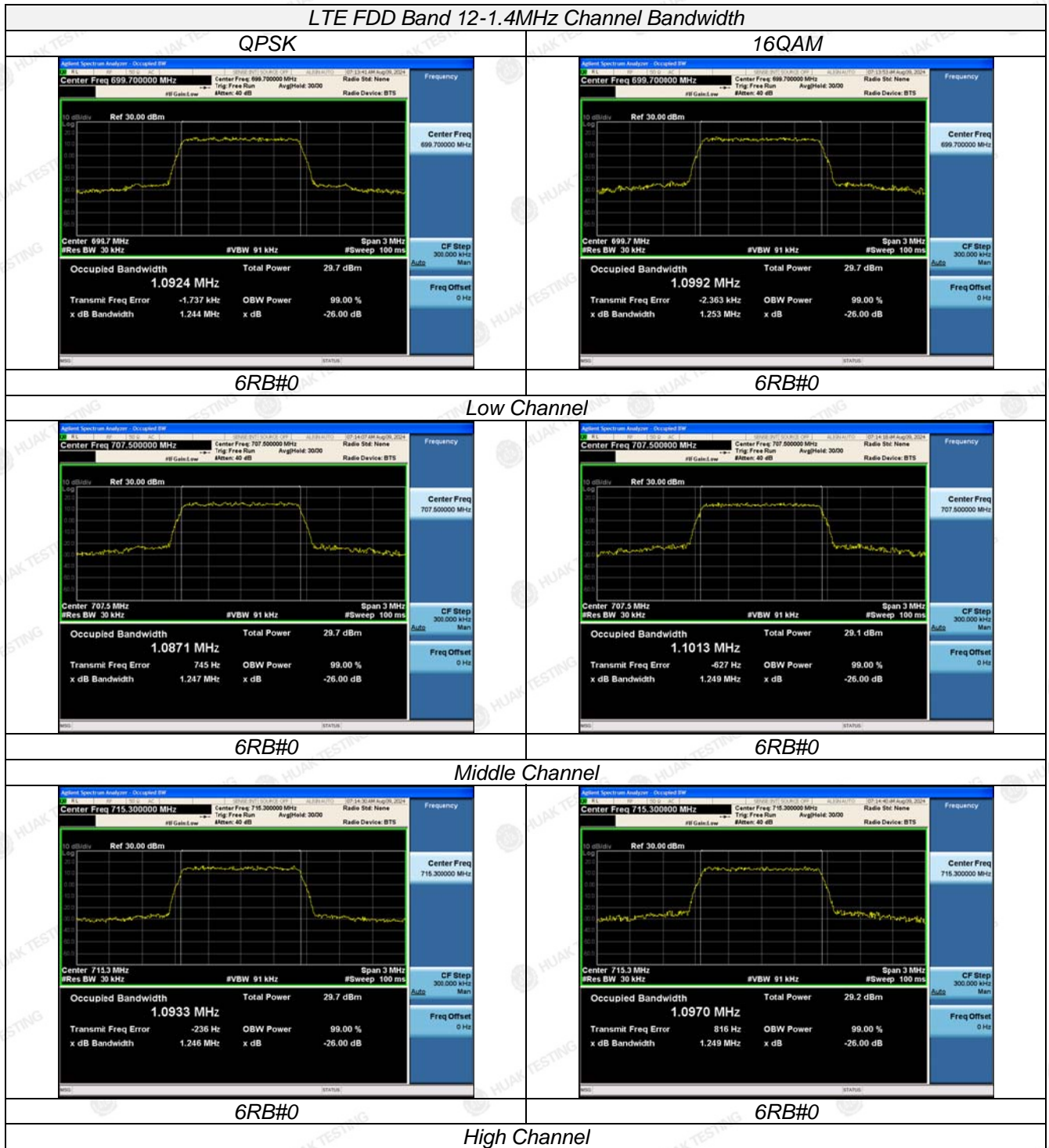

The results shown in this test report refer only to the sample(s) tested unless otherwise stated and the sample(s) are retained for 30 days only. The document is issued by HUAJ, this document cannot be reproduced except in full with our prior written permission. The more details and the authenticity of the report will be confirmed at <http://www.cer-mark.com>.

TEL : +86-755 2302 9901 FAX : +86-755 2302 9901 E-mail : service@cer-mark.com

Add: 1-2F., Building B2, Junfeng Zhongcheng Zhizao Innovation Park, Heping Community, Fuhai Street, Bao'an District, Shenzhen, Guangdong, China



The results shown in this test report refer only to the sample(s) tested unless otherwise stated and the sample(s) are retained for 30 days only. The document is issued by HUAJ, this document cannot be reproduced except in full with our prior written permission. The more details and the authenticity of the report will be confirmed at <http://www.cer-mark.com>.

TEL : +86-755 2302 9901 FAX : +86-755 2302 9901 E-mail : [service@cer-mark.com](mailto:service@cer-mark.com)

Add: 1-2F., Building B2, Junfeng Zhongcheng Zhizao Innovation Park, Heping Community, Fuhai Street, Bao'an District, Shenzhen, Guangdong, China



The results shown in this test report refer only to the sample(s) tested unless otherwise stated and the sample(s) are retained for 30 days only. The document is issued by HUAJ, this document cannot be reproduced except in full with our prior written permission. The more details and the authenticity of the report will be confirmed at <http://www.cer-mark.com>.

TEL : +86-755 2302 9901 FAX : +86-755 2302 9901 E-mail : service@cer-mark.com

Add: 1-2F., Building B2, Junfeng Zhongcheng Zhizao Innovation Park, Heping Community, Fuhai Street, Bao'an District, Shenzhen, Guangdong, China



The results shown in this test report refer only to the sample(s) tested unless otherwise stated and the sample(s) are retained for 30 days only. The document is issued by HUAJ, this document cannot be reproduced except in full with our prior written permission. The more details and the authenticity of the report will be confirmed at <http://www.cer-mark.com>.

TEL : +86-755 2302 9901 FAX : +86-755 2302 9901 E-mail : service@cer-mark.com

Add: 1-2F., Building B2, Junfeng Zhongcheng Zhizao Innovation Park, Heping Community, Fuhai Street, Bao'an District, Shenzhen, Guangdong, China

### 3.4 Band Edge Compliance

#### LIMIT

that the power of any emission outside of the authorized operating frequency ranges must be attenuated below the transmitting power (P) by a factor of at least  $43 + 10 \log (P)$  dB.

The specification that emissions shall be attenuated below the transmitter power (P) by at least  $43 + 10 \log (P)$  dB, translates in the relevant power range (1 to 0.001 W) to -13 dBm. At 1 W the specified minimum attenuation becomes 43 dB and relative to a 30 dBm (1 W) carrier becomes a limit of -13 dBm. At 0.001 W (0 dBm) the minimum attenuation is 13 dB, which again yields a limit of -13 dBm. In this way a translation of the specification from relative to absolute terms is carried out.

#### TEST CONFIGURATION

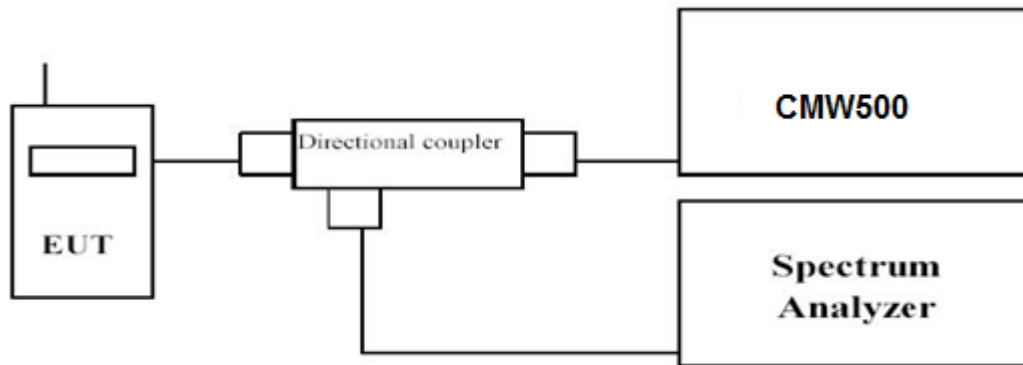

#### TEST PROCEDURE

1. The transmitter output port was connected to base station.
2. The RF output of EUT was connected to the power meter by RF cable and attenuator, the path loss was compensated to the results for each measurement.
3. Set EUT at maximum power through base station.
4. Select lowest and highest channels for each band and different modulation.
5. Measure Band edge using RMS (Average) detector by spectrum.

#### TEST RESULTS

Remark:

1. We were tested all RB Configuration refer 3GPP TS136 521 for each Channel Bandwidth of LTE FDD Band 12; recorded worst case for each Channel Bandwidth of LTE FDD Band 12.





LTE FDD Band 12-1.4MHz Channel Bandwidth Band Edge Compliance

QPSK

16QAM

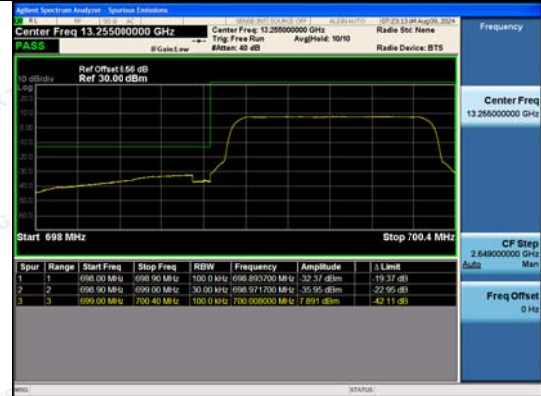
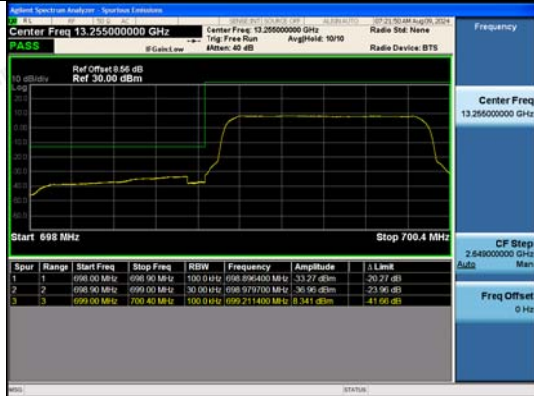

6RB#0

6RB#0

Low Channel

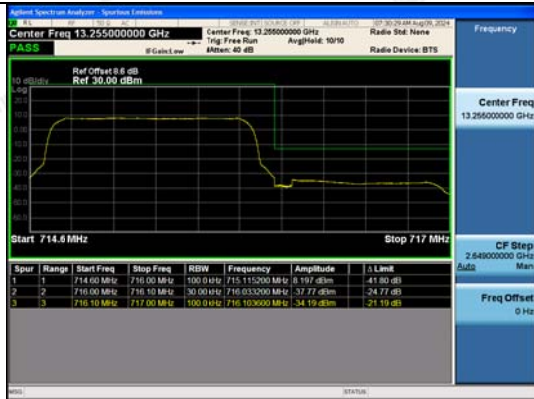

6RB#0

6RB#0

High Channel

LTE FDD Band 12-3MHz Channel Bandwidth Band Edge Compliance

QPSK

16QAM

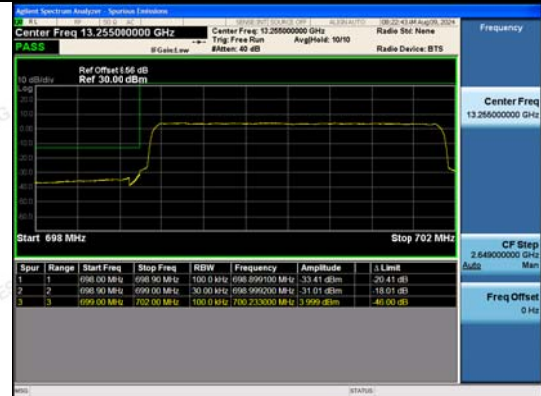
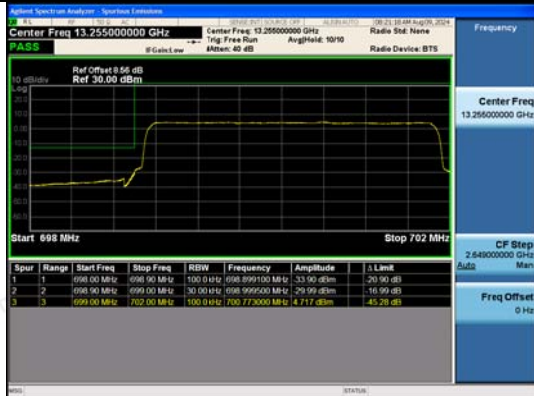

15RB#0

15RB#0

Low Channel

The results shown in this test report refer only to the sample(s) tested unless otherwise stated and the sample(s) are retained for 30 days only. The document is issued by HUAJ, this document cannot be reproduced except in full with our prior written permission. The more details and the authenticity of the report will be confirmed at http://www.cer-mark.com.

TEL : +86-755 2302 9901 FAX : +86-755 2302 9901 E-mail : service@cer-mark.com

Add: 1-2F., Building B2, Junfeng Zhongcheng Zhizao Innovation Park, Heping Community, Fuhai Street, Bao'an District, Shenzhen, Guangdong, China

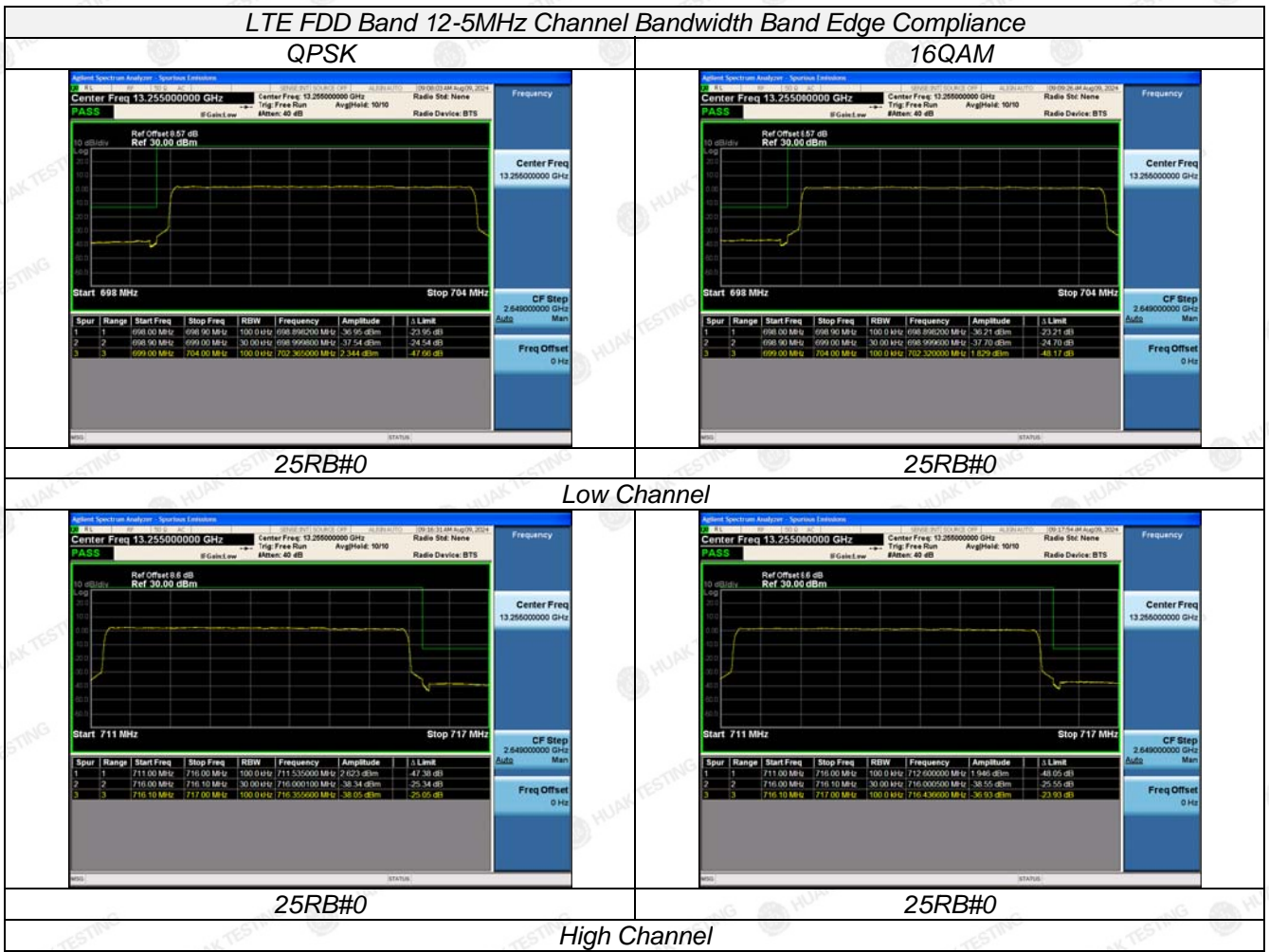
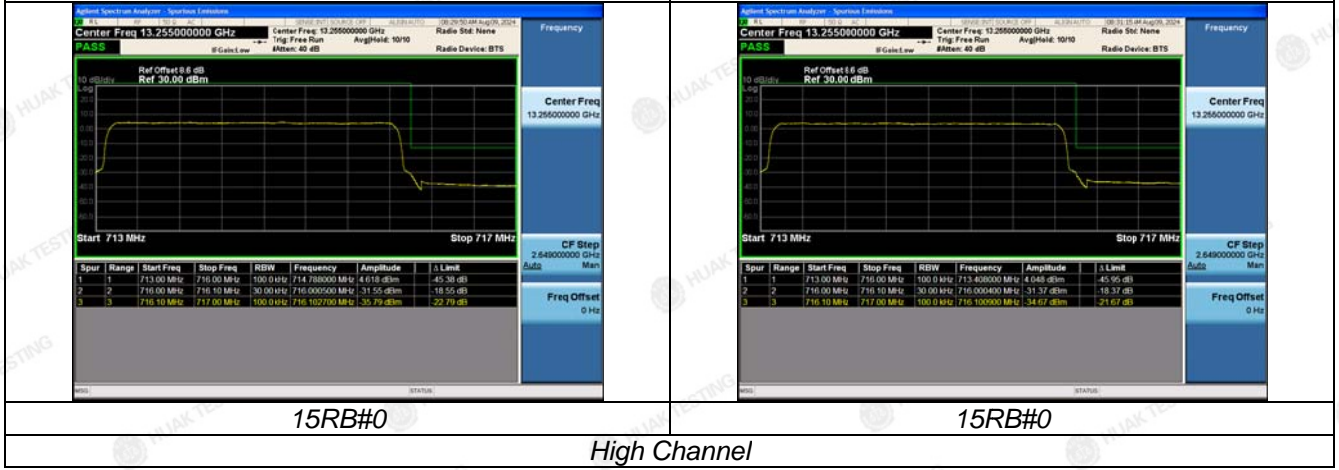

The results shown in this test report refer only to the sample(s) tested unless otherwise stated and the sample(s) are retained for 30 days only. The document is issued by HUAJ, this document cannot be reproduced except in full with our prior written permission. The more details and the authenticity of the report will be confirmed at <http://www.cer-mark.com>.

TEL : +86-755 2302 9901 FAX : +86-755 2302 9901 E-mail : service@cer-mark.com

Add: 1-2F., Building B2, Junfeng Zhongcheng Zhizao Innovation Park, Heping Community, Fuhai Street, Bao'an District, Shenzhen, Guangdong, China

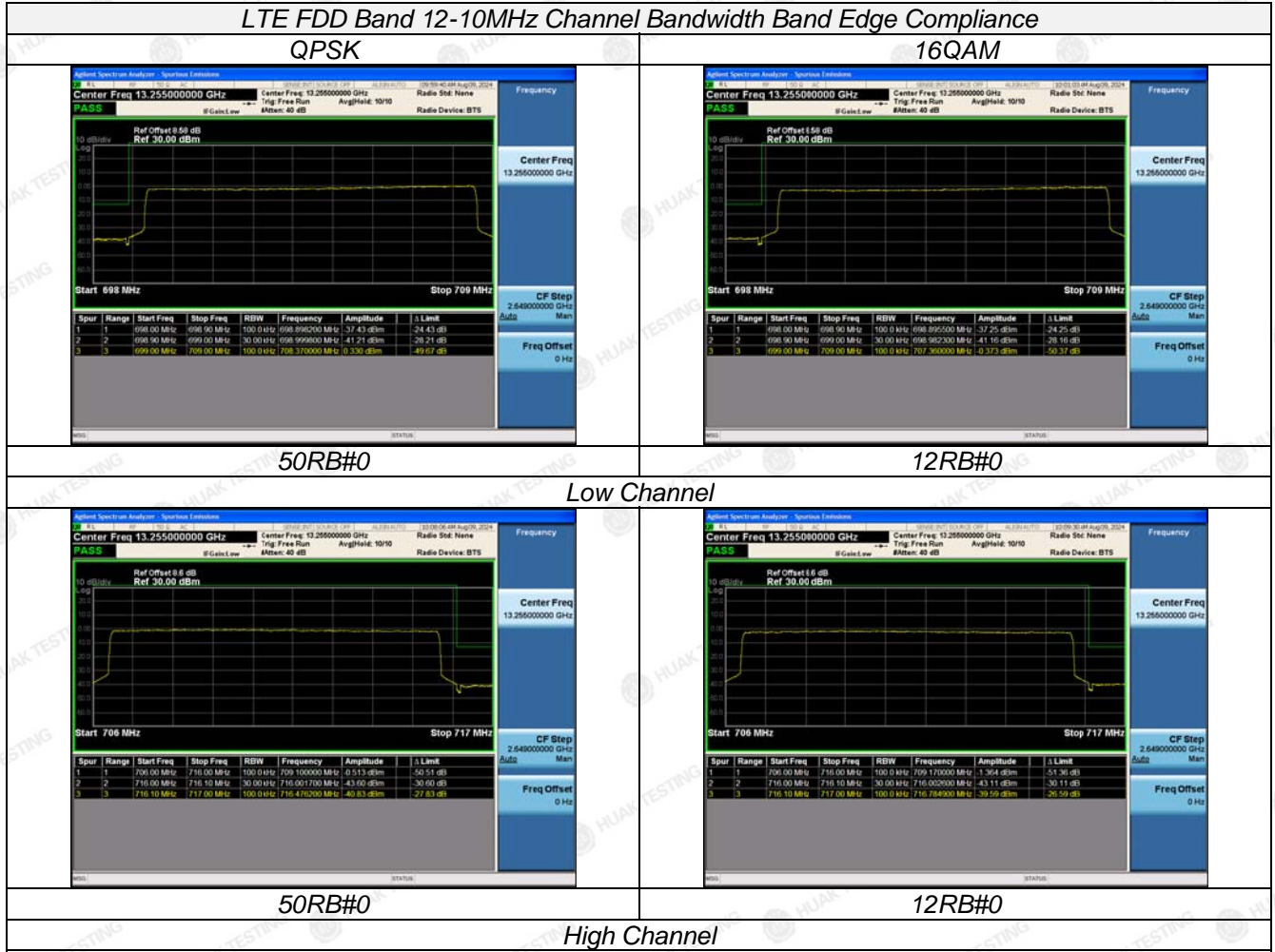

The results shown in this test report refer only to the sample(s) tested unless otherwise stated and the sample(s) are retained for 30 days only. The document is issued by HUAJ, this document cannot be reproduced except in full with our prior written permission. The more details and the authenticity of the report will be confirmed at <http://www.cer-mark.com>.

TEL : +86-755 2302 9901 FAX : +86-755 2302 9901 E-mail : service@cer-mark.com

Add: 1-2F., Building B2, Junfeng Zhongcheng Zhizao Innovation Park, Heping Community, Fuhai Street, Bao'an District, Shenzhen, Guangdong, China

### 3.5 Spurious Emission

#### LIMIT

that the power of any emission outside of the authorized operating frequency ranges must be attenuated below the transmitting power (P) by a factor of at least  $43 + 10 \log (P)$  dB.

The specification that emissions shall be attenuated below the transmitter power (P) by at least  $43 + 10 \log (P)$  dB, translates in the relevant power range (1 to 0.001 W) to -13 dBm. At 1 W the specified minimum attenuation becomes 43 dB and relative to a 30 dBm (1 W) carrier becomes a limit of -13 dBm. At 0.001 W (0 dBm) the minimum attenuation is 13 dB, which again yields a limit of -13 dBm. In this way a translation of the specification from relative to absolute terms is carried out.

#### TEST CONFIGURATION

##### Conducted Spurious Measurement:

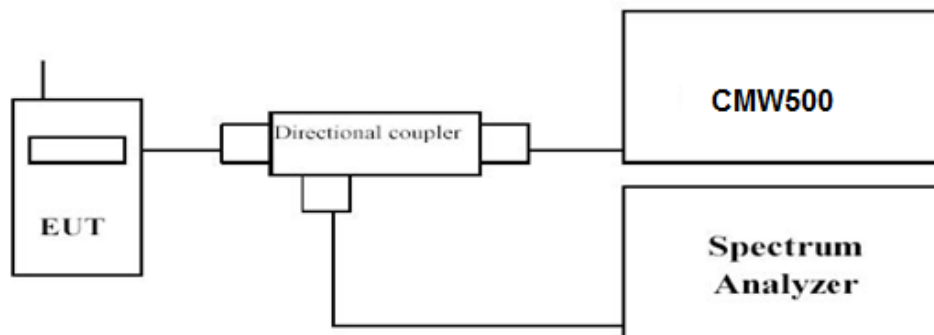

##### Radiated Spurious Measurement:

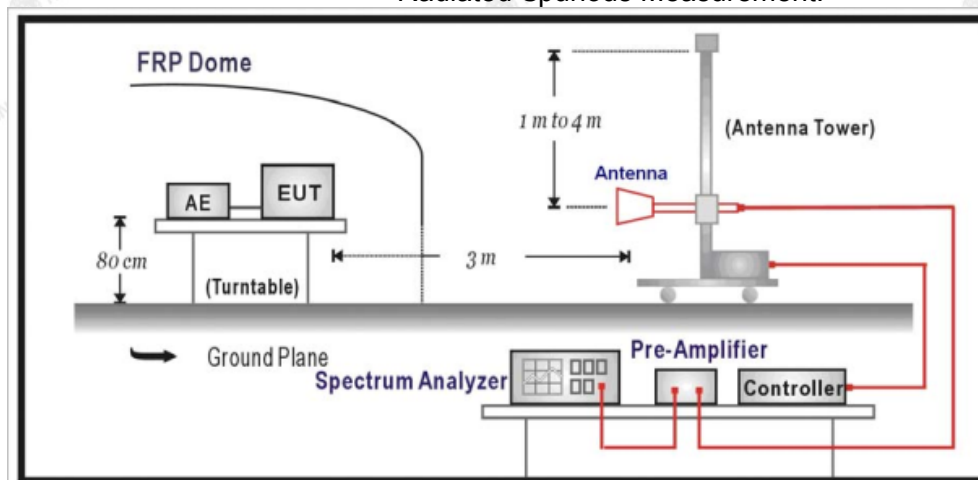

#### TEST PROCEDURE

The EUT was setup according to EIA/TIA 603D.

##### **Conducted Spurious Measurement:**

- Place the EUT on a bench and set it in transmitting mode.
- Connect a low loss RF cable from the antenna port to a spectrum analyzer and CMW500 by a Directional Coupler.
- EUT Communicate with CMW500, then select a channel for testing.
- Add a correction factor to the display of spectrum, and then test.
- The resolution bandwidth of the spectrum analyzer was set sufficient scans were taken to show the out of band Emission if any up to 10<sup>th</sup> harmonic.
- Please refer to following tables for test antenna conducted emissions.



g.

| Working Frequency | Sub range (GHz) | RBW   | VBW   | Sweep time (s) |
|-------------------|-----------------|-------|-------|----------------|
| LTE FDD Band 12   | 0.03~26.5       | 1 MHz | 3 MHz | Auto           |

**Radiated Spurious Measurement:**

- a. The EUT shall be placed at the specified height on a support, and in the position closest to normal use as declared by provider.
- b. The test antenna shall be oriented initially for vertical polarization and shall be chosen to correspond to the frequency of the transmitter.
- c. The output of the test antenna shall be connected to the measuring receiver.
- d. The transmitter shall be switched on and the measuring receiver shall be tuned to the frequency of the transmitter under test.
- e. The test antenna shall be raised and lowered through the specified range of height until a maximum signal level is detected by the measuring receiver.
- f. The transmitter shall then be rotated through 360° in the horizontal plane, until the maximum signal level is detected by the measuring receiver.
- g. The test antenna shall be raised and lowered again through the specified range of height until a maximum signal level is detected by the measuring receiver.
- h. The maximum signal level detected by the measuring receiver shall be noted.
- i. The transmitter shall be replaced by a substitution antenna.
- j. The substitution antenna shall be orientated for vertical polarization and the length of the substitution antenna shall be adjusted to correspond to the frequency of the transmitter.
- k. The substitution antenna shall be connected to a calibrated signal generator.
- l. If necessary, the input attenuator setting of the measuring receiver shall be adjusted in order to increase the sensitivity of the measuring receiver.
- m. The test antenna shall be raised and lowered through the specified range of height to ensure that the maximum signal is received.
- n. The input signal to the substitution antenna shall be adjusted to the level that produces a level detected by the measuring receiver, that is equal to the level noted while the transmitter radiated power was measured, corrected for the change of input attenuator setting of the measuring receiver.
- o. The measurement shall be repeated with the test antenna and the substitution antenna orientated for horizontal polarization.
- p. The measure of the effective radiated power is the larger of the two levels recorded at the input to the substitution antenna, corrected for gain of the substitution antenna if necessary.
- q. The resolution bandwidth of the spectrum analyzer was set at 100 kHz for Part 22 and 1MHz for Part 24. The frequency range was checked up to 10th harmonic.
- r. Test site anechoic chamber refer to ANSI C63.

**TEST RESULTS**

Remark:

- 1. We were tested all RB Configuration refer 3GPP TS136 521 for each Channel Bandwidth of LTE FDD Band 12; recorded worst case for each Channel Bandwidth of LTE FDD Band 12.

**Conducted Measurement:**



LTE FDD Band 12-1.4MHz Channel Bandwidth

Low Channel

QPSK

16QAM

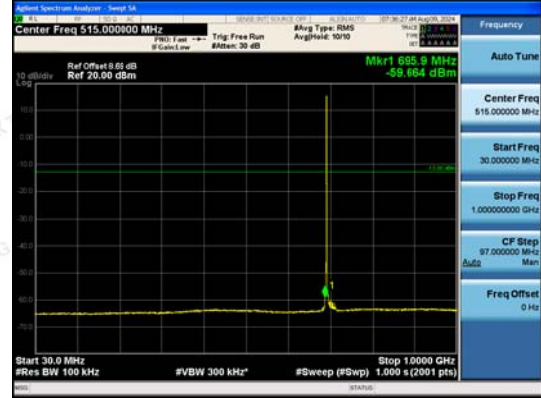
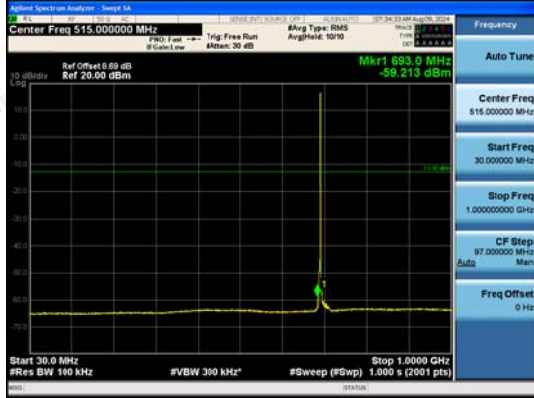

30MHz~1GHz

30MHz~1GHz

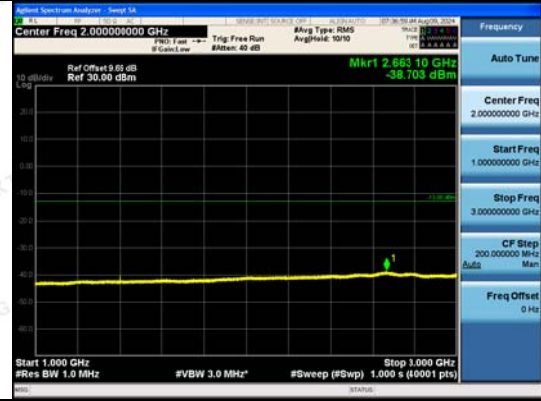

1GHz ~3GHz

1GHz ~3GHz

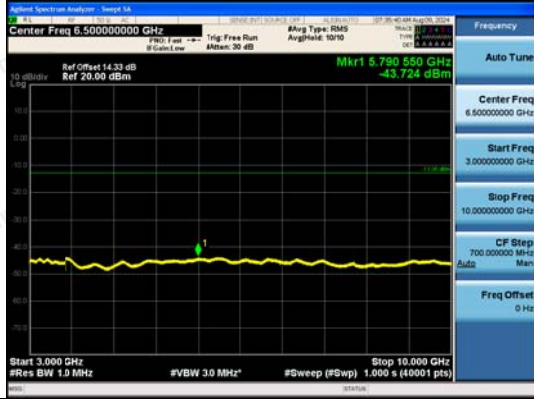

3GHz ~10GHz

3GHz ~10GHz

1RB#0

1RB#0

The results shown in this test report refer only to the sample(s) tested unless otherwise stated and the sample(s) are retained for 30 days only. The document is issued by HUAKE, this document cannot be reproduced except in full with our prior written permission. The more details and the authenticity of the report will be confirmed at <http://www.cer-mark.com>.

TEL : +86-755 2302 9901 FAX : +86-755 2302 9901 E-mail : service@cer-mark.com

Add: 1-2F., Building B2, Junfeng Zhongcheng Zhizao Innovation Park, Heping Community, Fuhai Street, Bao'an District, Shenzhen, Guangdong, China



LTE FDD Band 12-1.4MHz Channel Bandwidth  
Middle Channel

QPSK

16QAM

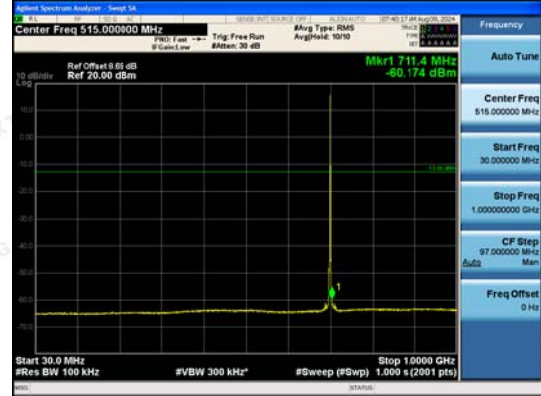
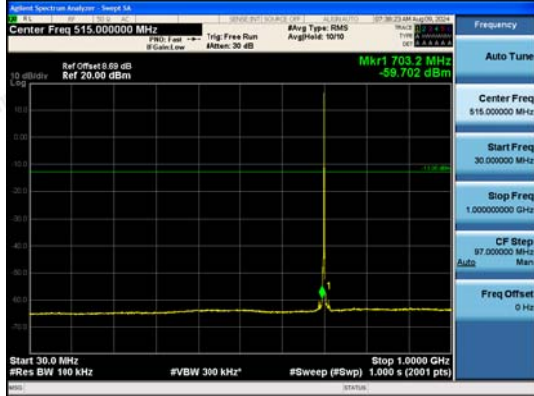

30MHz~1GHz

30MHz~1GHz



1GHz ~3GHz

1GHz ~3GHz

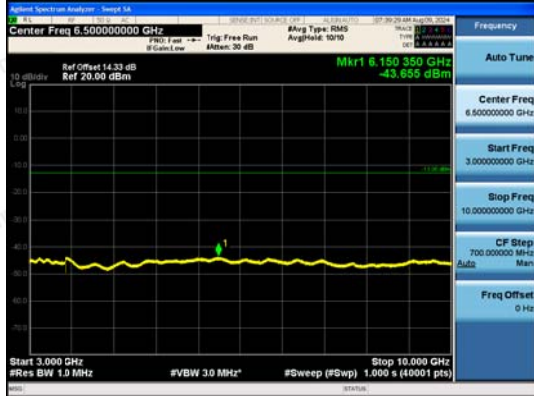

3GHz ~10GHz

3GHz ~10GHz

1RB#0

1RB#0

The results shown in this test report refer only to the sample(s) tested unless otherwise stated and the sample(s) are retained for 30 days only. The document is issued by HUAJAK, this document cannot be reproduced except in full with our prior written permission. The more details and the authenticity of the report will be confirmed at <http://www.cer-mark.com>.

TEL : +86-755 2302 9901 FAX : +86-755 2302 9901 E-mail : service@cer-mark.com

Add: 1-2F., Building B2, Junfeng Zhongcheng Zhizao Innovation Park, Heping Community, Fuhai Street, Bao'an District, Shenzhen, Guangdong, China



LTE FDD Band 12-1.4MHz Channel Bandwidth  
High Channel

QPSK

16QAM

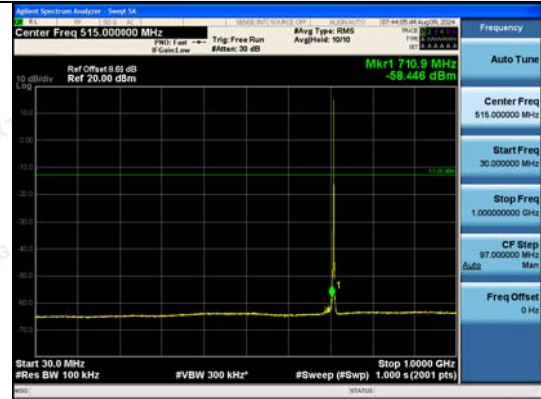

30MHz~1GHz

30MHz~1GHz



1GHz ~3GHz

1GHz ~3GHz

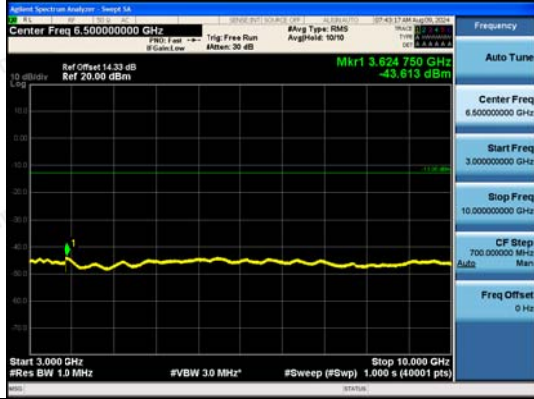

3GHz ~10GHz

3GHz ~10GHz

1RB#0

1RB#0

The results shown in this test report refer only to the sample(s) tested unless otherwise stated and the sample(s) are retained for 30 days only. The document is issued by HUAJ, this document cannot be reproduced except in full with our prior written permission. The more details and the authenticity of the report will be confirmed at <http://www.cer-mark.com>.

TEL : +86-755 2302 9901 FAX : +86-755 2302 9901 E-mail : service@cer-mark.com

Add: 1-2F., Building B2, Junfeng Zhongcheng Zhizao Innovation Park, Heping Community, Fuhai Street, Bao'an District, Shenzhen, Guangdong, China



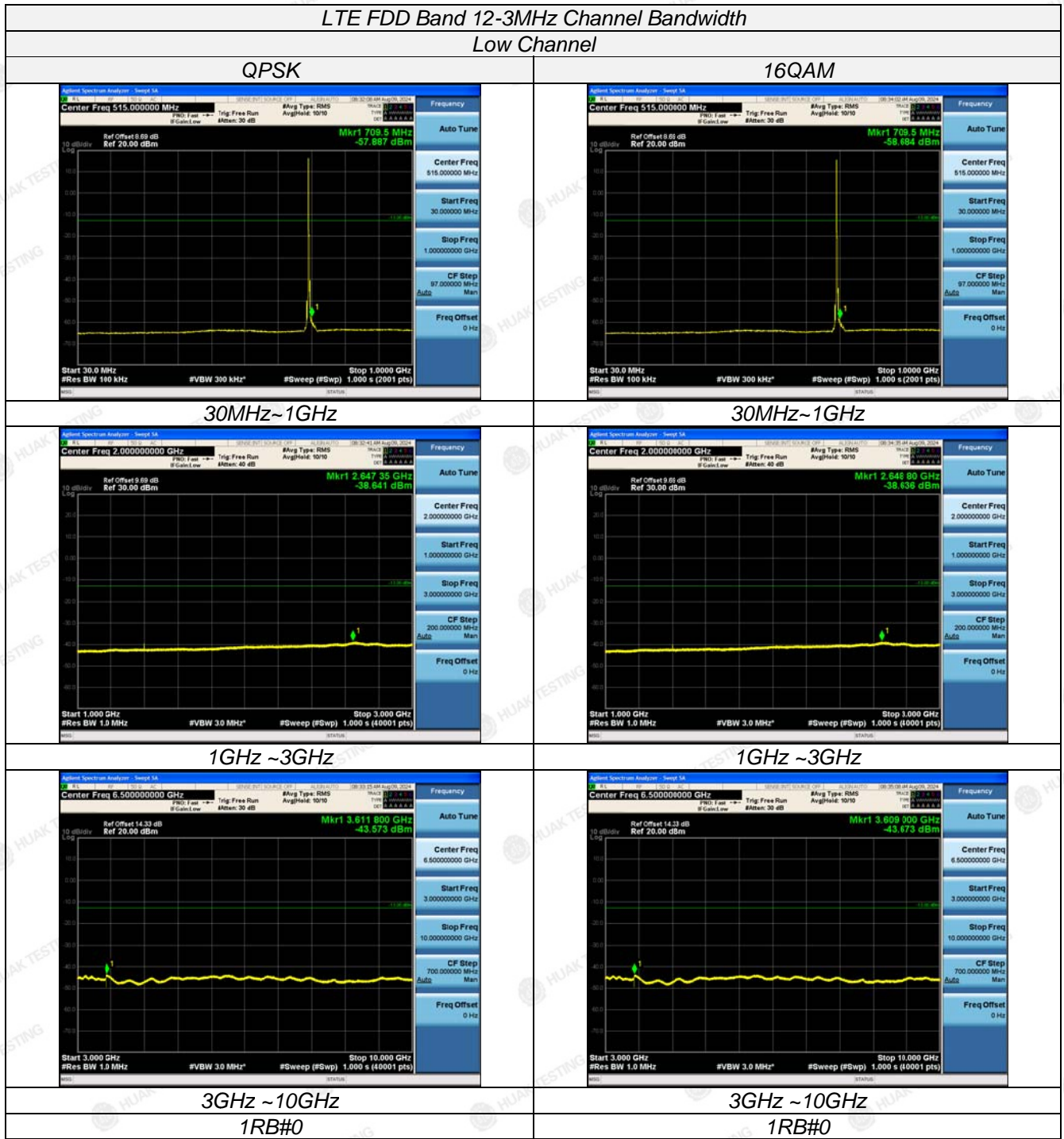

The results shown in this test report refer only to the sample(s) tested unless otherwise stated and the sample(s) are retained for 30 days only. The document is issued by HUAJAK, this document cannot be reproduced except in full with our prior written permission. The more details and the authenticity of the report will be confirmed at <http://www.cer-mark.com>.

TEL : +86-755 2302 9901 FAX : +86-755 2302 9901 E-mail : service@cer-mark.com

Add: 1-2F., Building B2, Junfeng Zhongcheng Zhizao Innovation Park, Heping Community, Fuhai Street, Bao'an District, Shenzhen, Guangdong, China

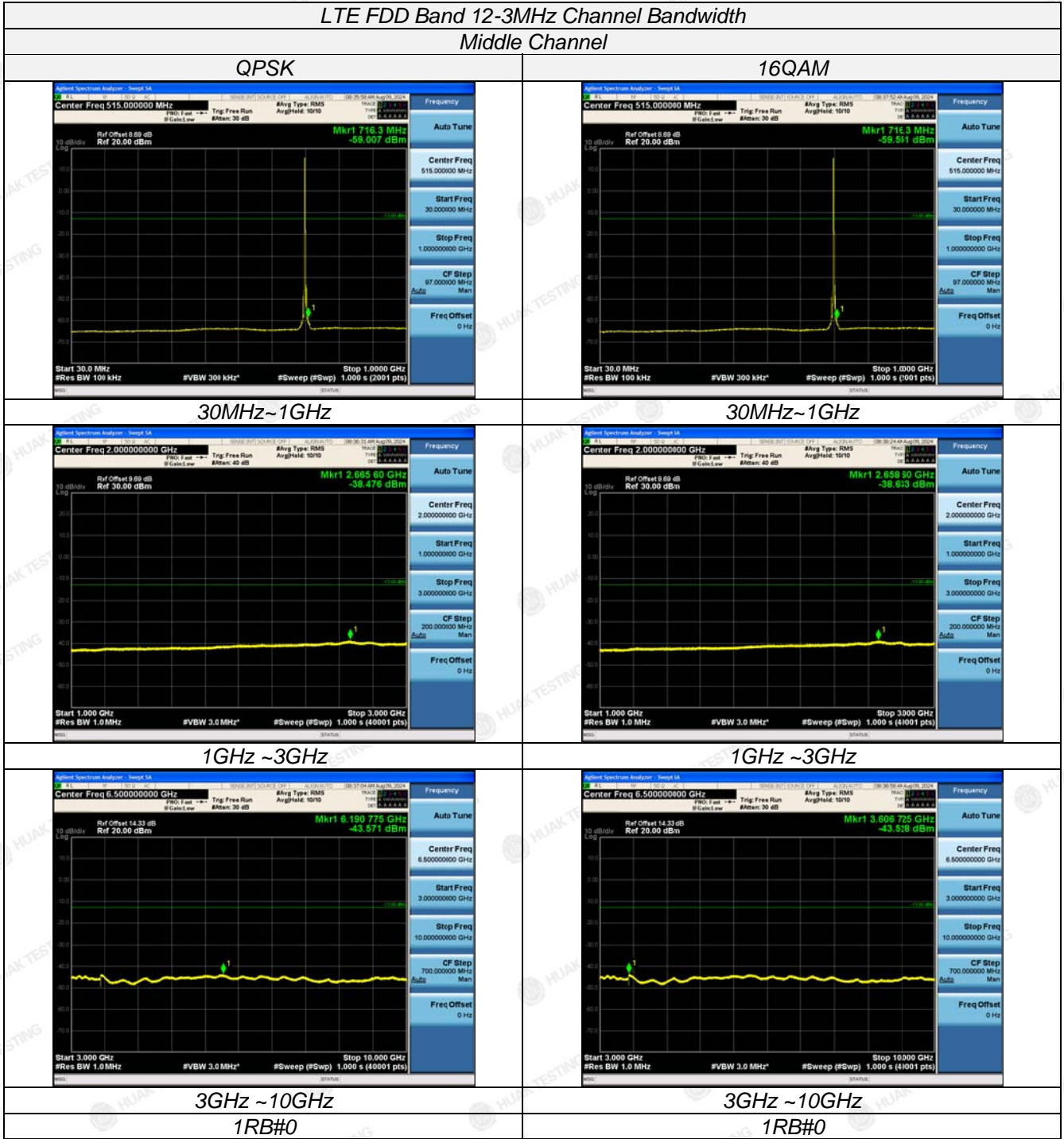

The results shown in this test report refer only to the sample(s) tested unless otherwise stated and the sample(s) are retained for 30 days only. The document is issued by HUAJ, this document cannot be reproduced except in full with our prior written permission. The more details and the authenticity of the report will be confirmed at <http://www.cer-mark.com>.

TEL : +86-755 2302 9901 FAX : +86-755 2302 9901 E-mail : service@cer-mark.com

Add: 1-2F., Building B2, Junfeng Zhongcheng Zhizao Innovation Park, Heping Community, Fuhai Street, Bao'an District, Shenzhen, Guangdong, China

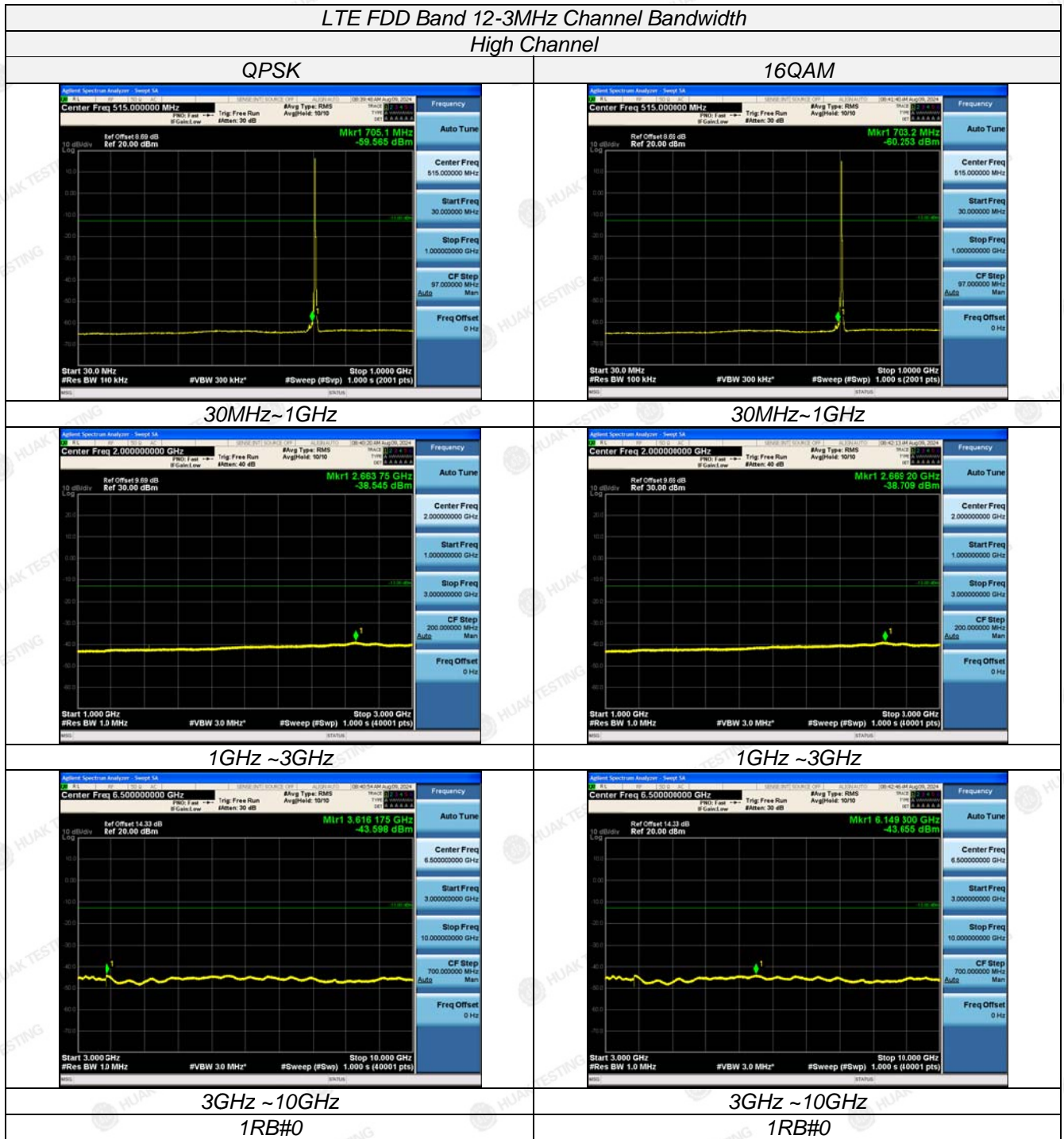

The results shown in this test report refer only to the sample(s) tested unless otherwise stated and the sample(s) are retained for 30 days only. The document is issued by HUAJAK, this document cannot be reproduced except in full with our prior written permission. The more details and the authenticity of the report will be confirmed at <http://www.cer-mark.com>.

TEL : +86-755 2302 9901 FAX : +86-755 2302 9901 E-mail : service@cer-mark.com

Add: 1-2F., Building B2, Junfeng Zhongcheng Zhizao Innovation Park, Heping Community, Fuhai Street, Bao'an District, Shenzhen, Guangdong, China

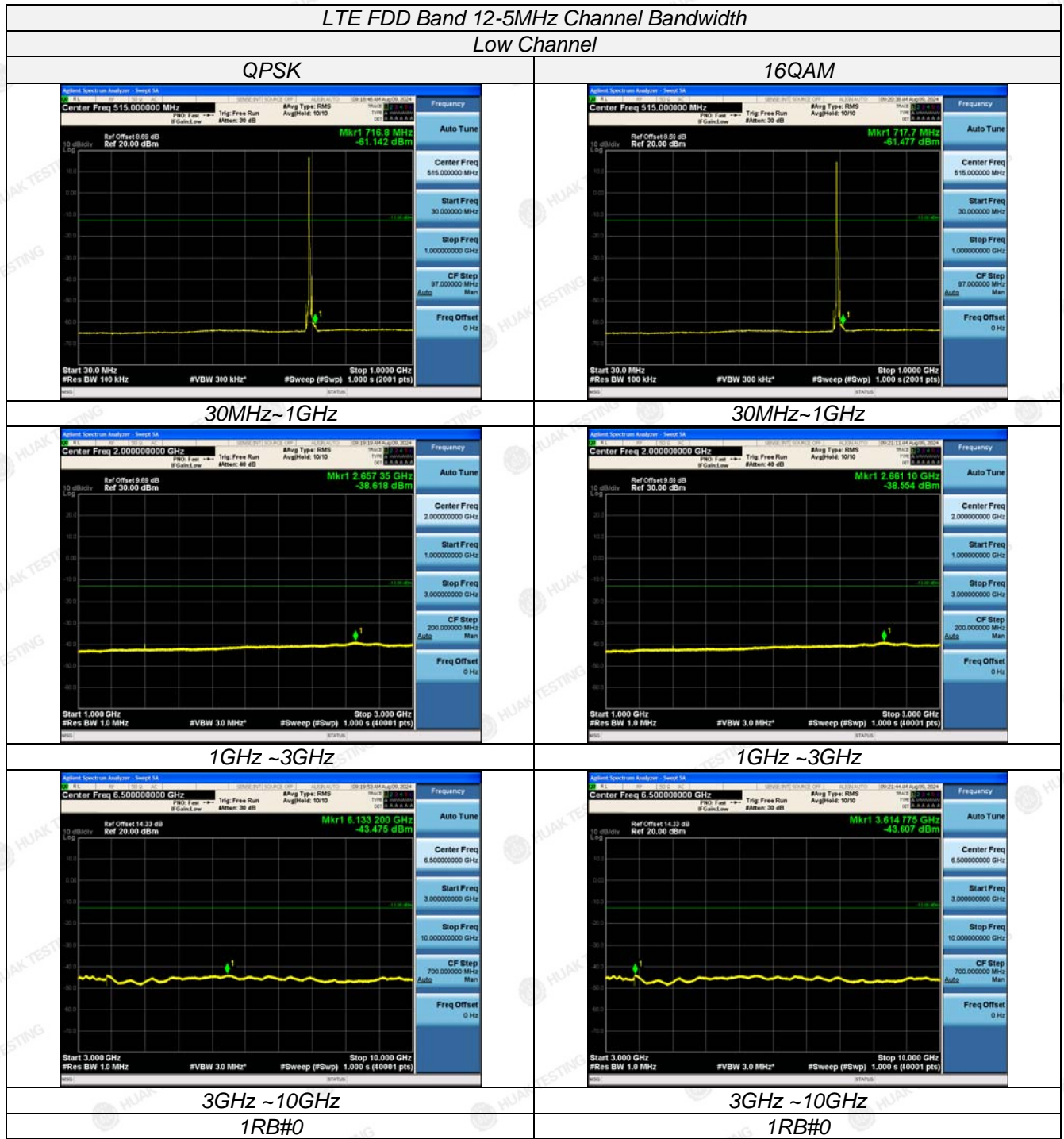

The results shown in this test report refer only to the sample(s) tested unless otherwise stated and the sample(s) are retained for 30 days only. The document is issued by HUAJ, this document cannot be reproduced except in full with our prior written permission. The more details and the authenticity of the report will be confirmed at <http://www.cer-mark.com>.

TEL : +86-755 2302 9901 FAX : +86-755 2302 9901 E-mail : service@cer-mark.com

Add: 1-2F., Building B2, Junfeng Zhongcheng Zhizao Innovation Park, Heping Community, Fuhai Street, Bao'an District, Shenzhen, Guangdong, China

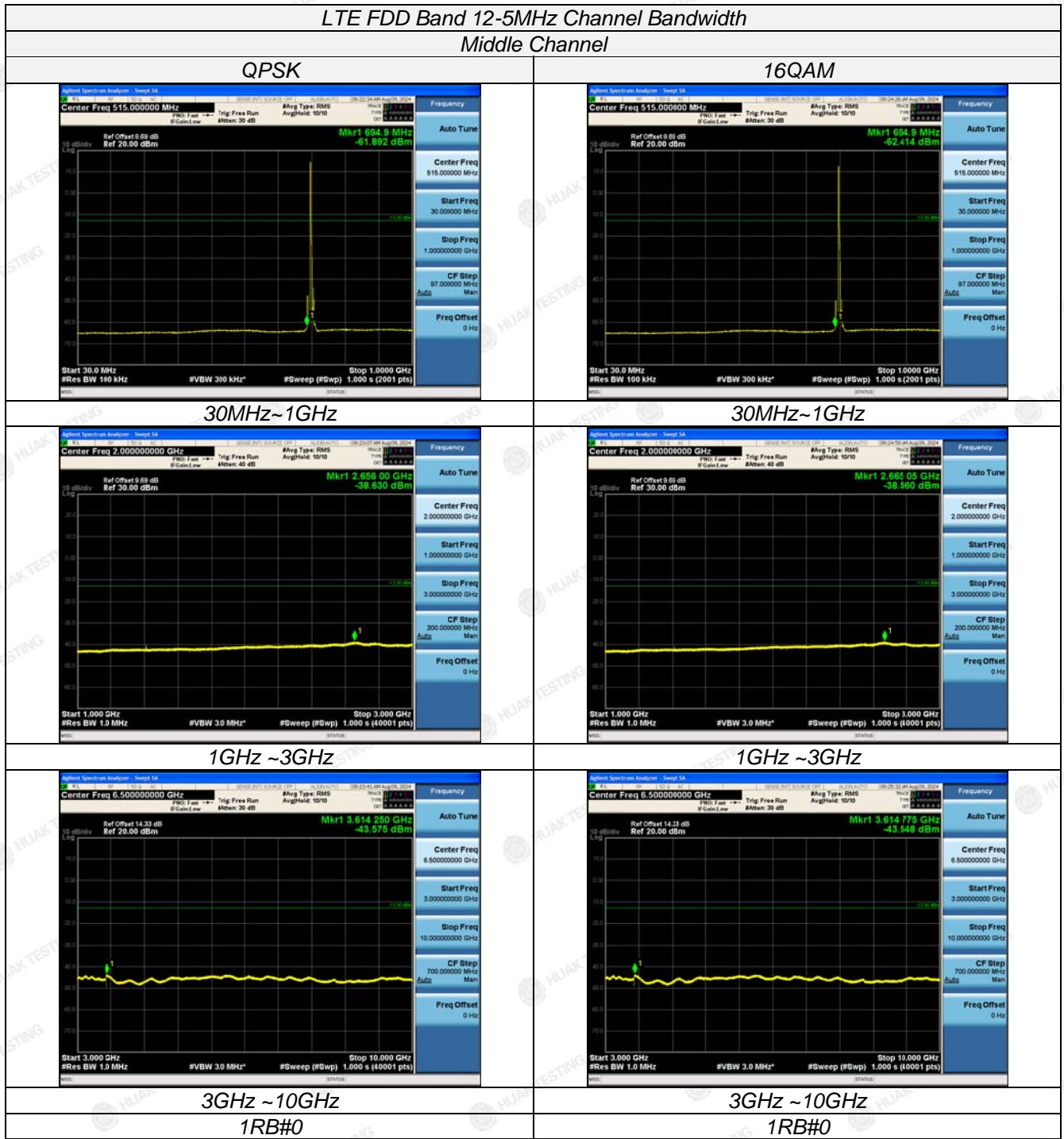

The results shown in this test report refer only to the sample(s) tested unless otherwise stated and the sample(s) are retained for 30 days only. The document is issued by HUAJAK, this document cannot be reproduced except in full with our prior written permission. The more details and the authenticity of the report will be confirmed at <http://www.cer-mark.com>.

TEL : +86-755 2302 9901 FAX : +86-755 2302 9901 E-mail : service@cer-mark.com

Add: 1-2F., Building B2, Junfeng Zhongcheng Zhizao Innovation Park, Heping Community, Fuhai Street, Bao'an District, Shenzhen, Guangdong, China



LTE FDD Band 12-5MHz Channel Bandwidth  
High Channel

QPSK

16QAM

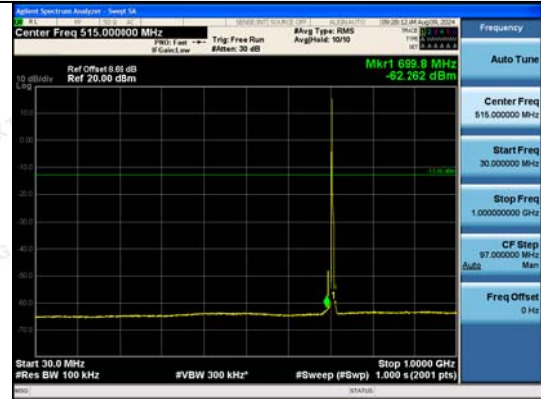
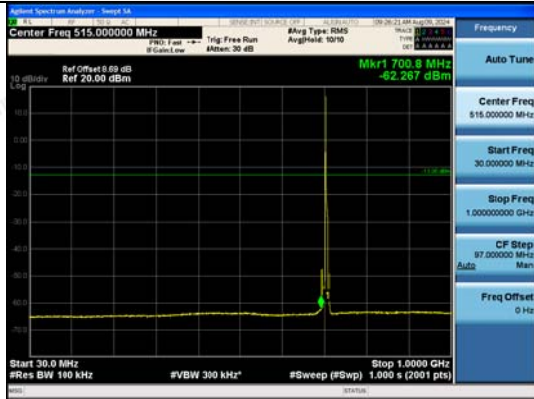

30MHz~1GHz

30MHz~1GHz



1GHz ~3GHz

1GHz ~3GHz

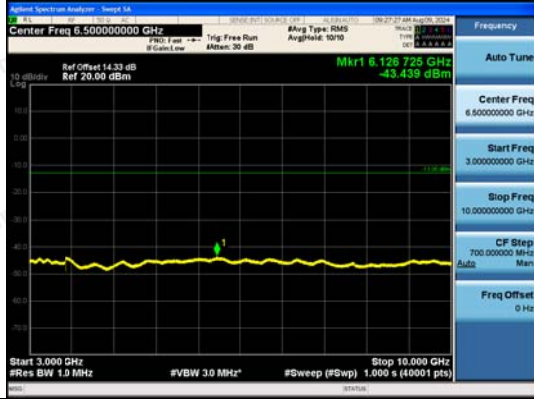

3GHz ~10GHz

3GHz ~10GHz

1RB#0

1RB#0

The results shown in this test report refer only to the sample(s) tested unless otherwise stated and the sample(s) are retained for 30 days only. The document is issued by HUAJAK, this document cannot be reproduced except in full with our prior written permission. The more details and the authenticity of the report will be confirmed at <http://www.cer-mark.com>.

TEL : +86-755 2302 9901 FAX : +86-755 2302 9901 E-mail : service@cer-mark.com

Add: 1-2F., Building B2, Junfeng Zhongcheng Zhizao Innovation Park, Heping Community, Fuhai Street, Bao'an District, Shenzhen, Guangdong, China

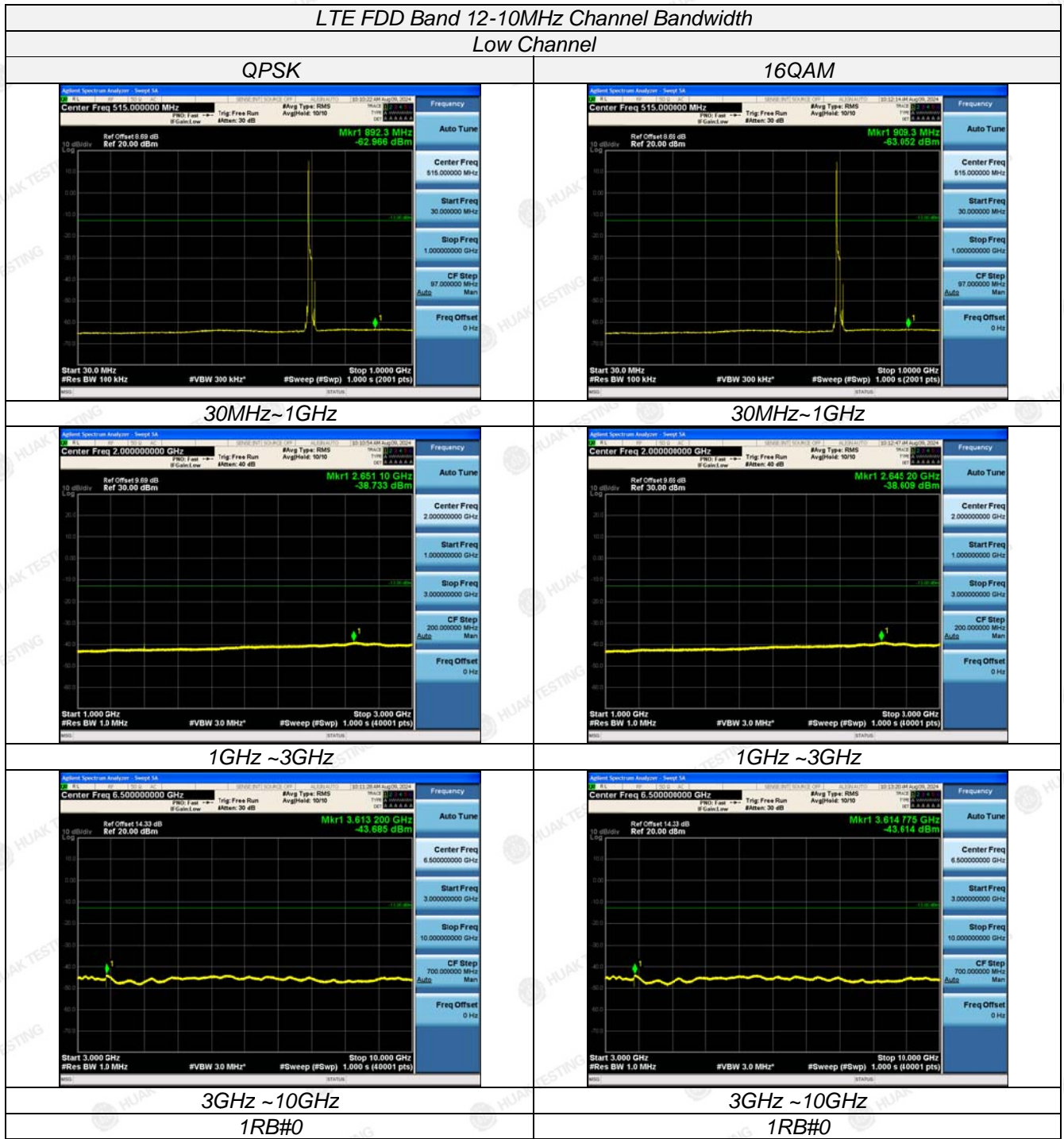

The results shown in this test report refer only to the sample(s) tested unless otherwise stated and the sample(s) are retained for 30 days only. The document is issued by HUAJAK, this document cannot be reproduced except in full with our prior written permission. The more details and the authenticity of the report will be confirmed at <http://www.cer-mark.com>.

TEL : +86-755 2302 9901 FAX : +86-755 2302 9901 E-mail : service@cer-mark.com

Add: 1-2F., Building B2, Junfeng Zhongcheng Zhizao Innovation Park, Heping Community, Fuhai Street, Bao'an District, Shenzhen, Guangdong, China



LTE FDD Band 12-10MHz Channel Bandwidth  
Middle Channel

QPSK

16QAM

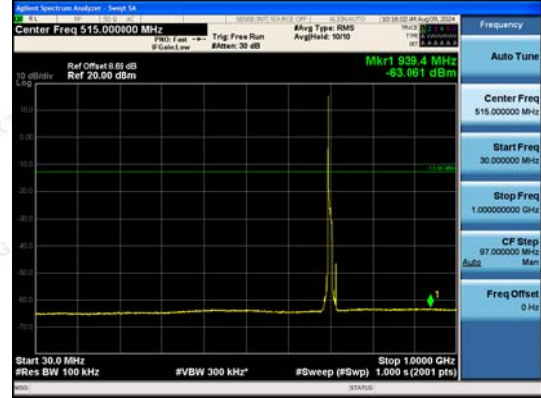
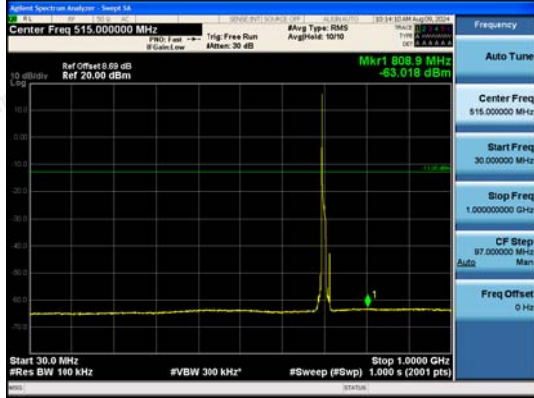

30MHz~1GHz

30MHz~1GHz

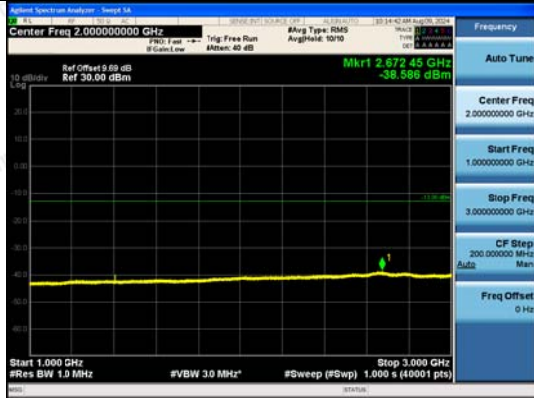

1GHz ~3GHz

1GHz ~3GHz

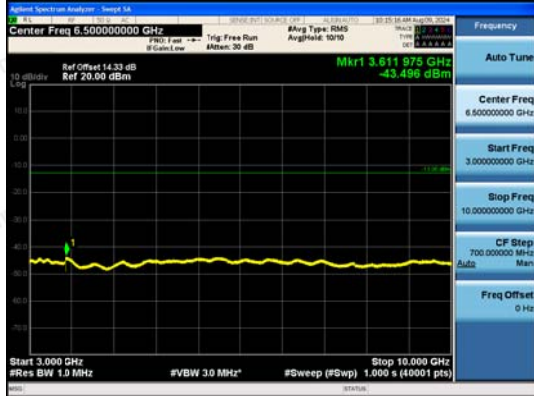

3GHz ~10GHz

3GHz ~10GHz

1RB#0

1RB#0

The results shown in this test report refer only to the sample(s) tested unless otherwise stated and the sample(s) are retained for 30 days only. The document is issued by HUAKE, this document cannot be reproduced except in full with our prior written permission. The more details and the authenticity of the report will be confirmed at <http://www.cer-mark.com>.

TEL : +86-755 2302 9901 FAX : +86-755 2302 9901 E-mail : service@cer-mark.com

Add: 1-2F., Building B2, Junfeng Zhongcheng Zhizao Innovation Park, Heping Community, Fuhai Street, Bao'an District, Shenzhen, Guangdong, China





LTE FDD Band 12-10MHz Channel Bandwidth  
High Channel

QPSK

16QAM

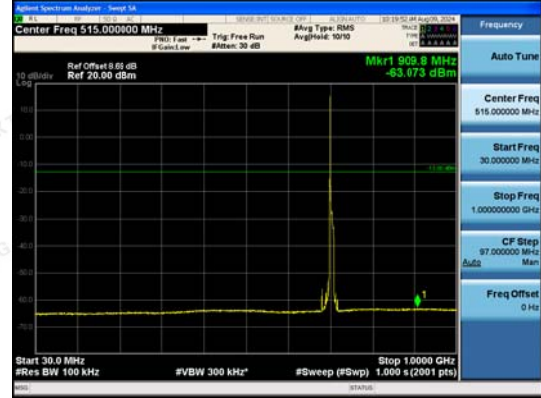
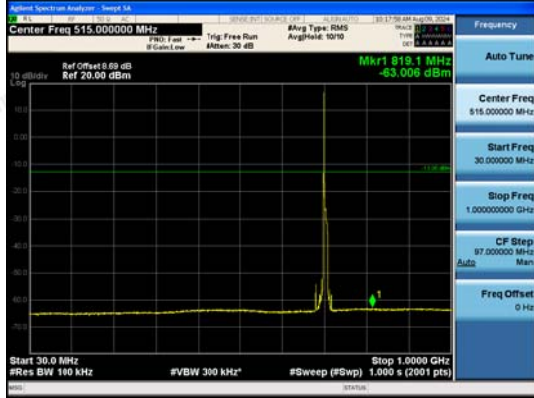

30MHz~1GHz

30MHz~1GHz



1GHz ~3GHz

1GHz ~3GHz

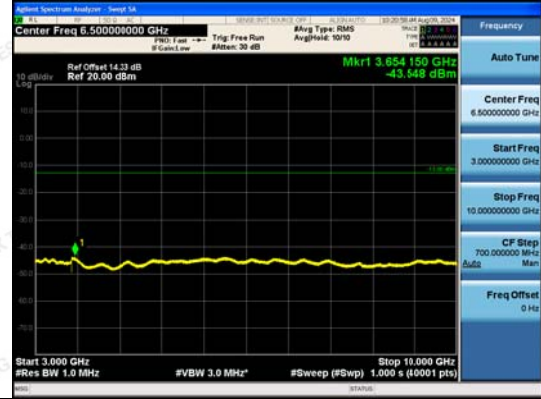
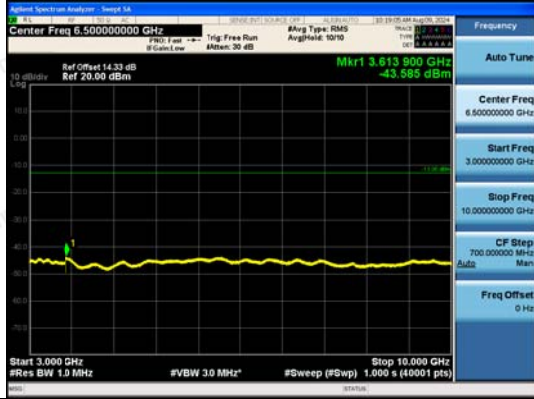

3GHz ~10GHz

3GHz ~10GHz

1RB#0

1RB#0

The results shown in this test report refer only to the sample(s) tested unless otherwise stated and the sample(s) are retained for 30 days only. The document is issued by HUAJAK, this document cannot be reproduced except in full with our prior written permission. The more details and the authenticity of the report will be confirmed at <http://www.cer-mark.com>.

TEL : +86-755 2302 9901 FAX : +86-755 2302 9901 E-mail : service@cer-mark.com

Add: 1-2F., Building B2, Junfeng Zhongcheng Zhizao Innovation Park, Heping Community, Fuhai Street, Bao'an District, Shenzhen, Guangdong, China



**Radiated Measurement:**

Remark:

1. We were tested all RB Configuration refer 3GPP TS136 521 for each Channel Bandwidth of LTE FDD Band 12; recorded worst case for each Channel Bandwidth of LTE FDD Band 12.
2.  $EIRP = P_{Mea}(dBm) - P_{cl}(dB) + G_a(dBi)$
3. We were not recorded other points as values lower than limits.
4. Margin = Limit - EIRP

*LTE FDD Band 12\_Channel Bandwidth 1.4MHz\_QPSK\_Low Channel*

| Frequency (MHz) | P <sub>Mea</sub> (dBm) | P <sub>cl</sub> (dB) | Diatance | G <sub>a</sub> Antenna Gain(dB) | Peak EIRP (dBm) | Limit (dBm) | Margin (dB) | Polarization |
|-----------------|------------------------|----------------------|----------|---------------------------------|-----------------|-------------|-------------|--------------|
| 1399.4          | -46.36                 | 2.86                 | 3.00     | 7.25                            | -44.12          | -13.00      | 31.12       | H            |
| 2099.1          | -45.7                  | 2.94                 | 3.00     | 9.53                            | -41.26          | -13.00      | 28.26       | H            |
| 1399.4          | -45.6                  | 2.86                 | 3.00     | 7.25                            | -43.36          | -13.00      | 30.36       | V            |
| 2099.1          | -49.47                 | 2.94                 | 3.00     | 9.53                            | -45.03          | -13.00      | 32.03       | V            |

*LTE FDD Band 12\_Channel Bandwidth 1.4MHz\_QPSK\_Middle Channel*

| Frequency (MHz) | P <sub>Mea</sub> (dBm) | P <sub>cl</sub> (dB) | Diatance | G <sub>a</sub> Antenna Gain(dB) | EIRP (dBm) | Limit (dBm) | Margin (dB) | Polarization |
|-----------------|------------------------|----------------------|----------|---------------------------------|------------|-------------|-------------|--------------|
| 1415.0          | -45.87                 | 2.86                 | 3.00     | 7.25                            | -43.63     | -13.00      | 30.63       | H            |
| 2122.5          | -43.78                 | 2.94                 | 3.00     | 9.53                            | -39.34     | -13.00      | 26.34       | H            |
| 1415.0          | -48.1                  | 2.86                 | 3.00     | 7.25                            | -45.86     | -13.00      | 32.86       | V            |
| 2122.5          | -49.73                 | 2.94                 | 3.00     | 9.53                            | -45.29     | -13.00      | 32.29       | V            |

*LTE FDD Band 12\_Channel Bandwidth 1.4MHz\_QPSK\_High Channel*

| Frequency (MHz) | P <sub>Mea</sub> (dBm) | P <sub>cl</sub> (dB) | Diatance | G <sub>a</sub> Antenna Gain(dB) | EIRP (dBm) | Limit (dBm) | Margin (dB) | Polarization |
|-----------------|------------------------|----------------------|----------|---------------------------------|------------|-------------|-------------|--------------|
| 1430.6          | -45.21                 | 2.86                 | 3.00     | 7.25                            | -42.97     | -13.00      | 29.97       | H            |
| 2145.9          | -44.72                 | 2.94                 | 3.00     | 9.53                            | -40.28     | -13.00      | 27.28       | H            |
| 1430.6          | -47.45                 | 2.86                 | 3.00     | 7.25                            | -45.21     | -13.00      | 32.21       | V            |
| 2145.9          | -47.28                 | 2.94                 | 3.00     | 9.53                            | -42.84     | -13.00      | 29.84       | V            |

*LTE FDD Band 12\_Channel Bandwidth 3MHz\_QPSK\_Low Channel*

| Frequency (MHz) | P <sub>Mea</sub> (dBm) | P <sub>cl</sub> (dB) | Diatance | G <sub>a</sub> Antenna Gain(dB) | Peak EIRP (dBm) | Limit (dBm) | Margin (dB) | Polarization |
|-----------------|------------------------|----------------------|----------|---------------------------------|-----------------|-------------|-------------|--------------|
| 1401.0          | -47.4                  | 2.86                 | 3.00     | 7.25                            | -45.16          | -13.00      | 32.16       | H            |
| 2101.5          | -45.52                 | 2.94                 | 3.00     | 9.53                            | -41.08          | -13.00      | 28.08       | H            |
| 1401.0          | -45.46                 | 2.86                 | 3.00     | 7.25                            | -43.22          | -13.00      | 30.22       | V            |
| 2101.5          | -49.42                 | 2.94                 | 3.00     | 9.53                            | -44.98          | -13.00      | 31.98       | V            |

*LTE FDD Band 12\_Channel Bandwidth 3MHz\_QPSK\_Middle Channel*

| Frequency (MHz) | P <sub>Mea</sub> (dBm) | P <sub>cl</sub> (dB) | Diatance | G <sub>a</sub> Antenna Gain(dB) | EIRP (dBm) | Limit (dBm) | Margin (dB) | Polarization |
|-----------------|------------------------|----------------------|----------|---------------------------------|------------|-------------|-------------|--------------|
| 1415.0          | -46.8                  | 2.86                 | 3.00     | 7.25                            | -44.56     | -13.00      | 31.56       | H            |
| 2122.5          | -46.08                 | 2.94                 | 3.00     | 9.53                            | -41.64     | -13.00      | 28.64       | H            |
| 1415.0          | -45.38                 | 2.86                 | 3.00     | 7.25                            | -43.14     | -13.00      | 30.14       | V            |
| 2122.5          | -48.9                  | 2.94                 | 3.00     | 9.53                            | -44.46     | -13.00      | 31.46       | V            |



LTE FDD Band 12\_Channel Bandwidth 3MHz\_QPSK\_High Channel

| Frequency (MHz) | P <sub>Mea</sub> (dBm) | P <sub>cl</sub> (dB) | Diatance | G <sub>a</sub> Antenna Gain(dB) | EIRP (dBm) | Limit (dBm) | Margin (dB) | Polarization |
|-----------------|------------------------|----------------------|----------|---------------------------------|------------|-------------|-------------|--------------|
| 1429.0          | -44.92                 | 2.86                 | 3.00     | 7.25                            | -42.68     | -13.00      | 29.68       | H            |
| 2143.5          | -46.28                 | 2.94                 | 3.00     | 9.53                            | -41.84     | -13.00      | 28.84       | H            |
| 1429.0          | -46.38                 | 2.86                 | 3.00     | 7.25                            | -44.14     | -13.00      | 31.14       | V            |
| 2143.5          | -49.53                 | 2.94                 | 3.00     | 9.53                            | -45.09     | -13.00      | 32.09       | V            |

LTE FDD Band 12\_Channel Bandwidth 5MHz\_QPSK\_Low Channel

| Frequency (MHz) | P <sub>Mea</sub> (dBm) | P <sub>cl</sub> (dB) | Diatance | G <sub>a</sub> Antenna Gain(dB) | Peak EIRP (dBm) | Limit (dBm) | Margin (dB) | Polarization |
|-----------------|------------------------|----------------------|----------|---------------------------------|-----------------|-------------|-------------|--------------|
| 1403.0          | -46.23                 | 2.86                 | 3.00     | 7.25                            | -43.99          | -13.00      | 30.99       | H            |
| 2104.5          | -45.74                 | 2.94                 | 3.00     | 9.53                            | -41.3           | -13.00      | 28.3        | H            |
| 1403.0          | -48.08                 | 2.86                 | 3.00     | 7.25                            | -45.84          | -13.00      | 32.84       | V            |
| 2104.5          | -48.28                 | 2.94                 | 3.00     | 9.53                            | -43.84          | -13.00      | 30.84       | V            |

LTE FDD Band 12\_Channel Bandwidth 5MHz\_QPSK\_Middle Channel

| Frequency (MHz) | P <sub>Mea</sub> (dBm) | P <sub>cl</sub> (dB) | Diatance | G <sub>a</sub> Antenna Gain(dB) | EIRP (dBm) | Limit (dBm) | Margin (dB) | Polarization |
|-----------------|------------------------|----------------------|----------|---------------------------------|------------|-------------|-------------|--------------|
| 1415.0          | -44.85                 | 2.86                 | 3.00     | 7.25                            | -42.61     | -13.00      | 29.61       | H            |
| 2122.5          | -44.41                 | 2.94                 | 3.00     | 9.53                            | -39.97     | -13.00      | 26.97       | H            |
| 1415.0          | -47.87                 | 2.86                 | 3.00     | 7.25                            | -45.63     | -13.00      | 32.63       | V            |
| 2122.5          | -49.9                  | 2.94                 | 3.00     | 9.53                            | -45.46     | -13.00      | 32.46       | V            |

LTE FDD Band 12\_Channel Bandwidth 5MHz\_QPSK\_High Channel

| Frequency (MHz) | P <sub>Mea</sub> (dBm) | P <sub>cl</sub> (dB) | Diatance | G <sub>a</sub> Antenna Gain(dB) | EIRP (dBm) | Limit (dBm) | Margin (dB) | Polarization |
|-----------------|------------------------|----------------------|----------|---------------------------------|------------|-------------|-------------|--------------|
| 1427.0          | -45.44                 | 2.86                 | 3.00     | 7.25                            | -43.2      | -13.00      | 30.2        | H            |
| 2140.5          | -43.74                 | 2.94                 | 3.00     | 9.53                            | -39.3      | -13.00      | 26.3        | H            |
| 1427.0          | -46.66                 | 2.86                 | 3.00     | 7.25                            | -44.42     | -13.00      | 31.42       | V            |
| 2140.5          | -48.29                 | 2.94                 | 3.00     | 9.53                            | -43.85     | -13.00      | 30.85       | V            |

LTE FDD Band 12\_Channel Bandwidth 10MHz\_QPSK\_Low Channel

| Frequency (MHz) | P <sub>Mea</sub> (dBm) | P <sub>cl</sub> (dB) | Diatance | G <sub>a</sub> Antenna Gain(dB) | Peak EIRP (dBm) | Limit (dBm) | Margin (dB) | Polarization |
|-----------------|------------------------|----------------------|----------|---------------------------------|-----------------|-------------|-------------|--------------|
| 1408.0          | -45.84                 | 2.86                 | 3.00     | 7.25                            | -43.6           | -13.00      | 30.6        | H            |
| 2112.0          | -46.06                 | 2.94                 | 3.00     | 9.53                            | -41.62          | -13.00      | 28.62       | H            |
| 1408.0          | -47.92                 | 2.86                 | 3.00     | 7.25                            | -45.68          | -13.00      | 32.68       | V            |
| 2112.0          | -49.32                 | 2.94                 | 3.00     | 9.53                            | -44.88          | -13.00      | 31.88       | V            |

LTE FDD Band 12\_Channel Bandwidth 10MHz\_QPSK\_Middle Channel

| Frequency (MHz) | P <sub>Mea</sub> (dBm) | P <sub>cl</sub> (dB) | Diatance | G <sub>a</sub> Antenna Gain(dB) | EIRP (dBm) | Limit (dBm) | Margin (dB) | Polarization |
|-----------------|------------------------|----------------------|----------|---------------------------------|------------|-------------|-------------|--------------|
| 1415.0          | -46.77                 | 2.86                 | 3.00     | 7.25                            | -44.53     | -13.00      | 31.53       | H            |
| 2122.5          | -44.04                 | 2.94                 | 3.00     | 9.53                            | -39.6      | -13.00      | 26.6        | H            |
| 1415.0          | -46.05                 | 2.86                 | 3.00     | 7.25                            | -43.81     | -13.00      | 30.81       | V            |
| 2122.5          | -48.95                 | 2.94                 | 3.00     | 9.53                            | -44.51     | -13.00      | 31.51       | V            |

The results shown in this test report refer only to the sample(s) tested unless otherwise stated and the sample(s) are retained for 30 days only. The document is issued by HUAKE, this document cannot be reproduced except in full with our prior written permission. The more details and the authenticity of the report will be confirmed at <http://www.cer-mark.com>.

TEL : +86-755 2302 9901 FAX : +86-755 2302 9901 E-mail : service@cer-mark.com

Add: 1-2F., Building B2, Junfeng Zhongcheng Zhizao Innovation Park, Heping Community, Fuhai Street, Bao'an District, Shenzhen, Guangdong, China



LTE FDD Band 12\_Channel Bandwidth 10MHz\_QPSK\_High Channel

| Frequency (MHz) | P <sub>Mea</sub> (dBm) | P <sub>cl</sub> (dB) | Diatance | G <sub>a</sub> Antenna Gain(dB) | EIRP (dBm) | Limit (dBm) | Margin (dB) | Polarization |
|-----------------|------------------------|----------------------|----------|---------------------------------|------------|-------------|-------------|--------------|
| 1422.0          | -46.68                 | 2.86                 | 3.00     | 7.25                            | -44.44     | -13.00      | 31.44       | H            |
| 2133.0          | -46.13                 | 2.94                 | 3.00     | 9.53                            | -41.69     | -13.00      | 28.69       | H            |
| 1422.0          | -47.61                 | 2.86                 | 3.00     | 7.25                            | -45.37     | -13.00      | 32.37       | V            |
| 2133.0          | -47.96                 | 2.94                 | 3.00     | 9.53                            | -43.52     | -13.00      | 30.52       | V            |

LTE FDD Band 12\_Channel Bandwidth 1.4MHz\_16QAM\_Low Channel

| Frequency (MHz) | P <sub>Mea</sub> (dBm) | P <sub>cl</sub> (dB) | Diatance | G <sub>a</sub> Antenna Gain(dB) | Peak EIRP (dBm) | Limit (dBm) | Margin (dB) | Polarization |
|-----------------|------------------------|----------------------|----------|---------------------------------|-----------------|-------------|-------------|--------------|
| 1399.4          | -45.69                 | 2.86                 | 3.00     | 7.25                            | -43.45          | -13.00      | 30.45       | H            |
| 2099.1          | -44.95                 | 2.94                 | 3.00     | 9.53                            | -40.51          | -13.00      | 27.51       | H            |
| 1399.4          | -45.49                 | 2.86                 | 3.00     | 7.25                            | -43.25          | -13.00      | 30.25       | V            |
| 2099.1          | -47.47                 | 2.94                 | 3.00     | 9.53                            | -43.03          | -13.00      | 30.03       | V            |

LTE FDD Band 12\_Channel Bandwidth 1.4MHz\_16QAM\_Middle Channel

| Frequency (MHz) | P <sub>Mea</sub> (dBm) | P <sub>cl</sub> (dB) | Diatance | G <sub>a</sub> Antenna Gain(dB) | EIRP (dBm) | Limit (dBm) | Margin (dB) | Polarization |
|-----------------|------------------------|----------------------|----------|---------------------------------|------------|-------------|-------------|--------------|
| 1415.0          | -46.04                 | 2.86                 | 3.00     | 7.25                            | -43.8      | -13.00      | 30.8        | H            |
| 2122.5          | -46.25                 | 2.94                 | 3.00     | 9.53                            | -41.81     | -13.00      | 28.81       | H            |
| 1415.0          | -45.69                 | 2.86                 | 3.00     | 7.25                            | -43.45     | -13.00      | 30.45       | V            |
| 2122.5          | -47.8                  | 2.94                 | 3.00     | 9.53                            | -43.36     | -13.00      | 30.36       | V            |

LTE FDD Band 12\_Channel Bandwidth 1.4MHz\_16QAM\_High Channel

| Frequency (MHz) | P <sub>Mea</sub> (dBm) | P <sub>cl</sub> (dB) | Diatance | G <sub>a</sub> Antenna Gain(dB) | EIRP (dBm) | Limit (dBm) | Margin (dB) | Polarization |
|-----------------|------------------------|----------------------|----------|---------------------------------|------------|-------------|-------------|--------------|
| 1430.6          | -45.75                 | 2.86                 | 3.00     | 7.25                            | -43.51     | -13.00      | 30.51       | H            |
| 2145.9          | -46                    | 2.94                 | 3.00     | 9.53                            | -41.56     | -13.00      | 28.56       | H            |
| 1430.6          | -45.98                 | 2.86                 | 3.00     | 7.25                            | -43.74     | -13.00      | 30.74       | V            |
| 2145.9          | -47.47                 | 2.94                 | 3.00     | 9.53                            | -43.03     | -13.00      | 30.03       | V            |

LTE FDD Band 12\_Channel Bandwidth 3MHz\_16QAM\_Low Channel

| Frequency (MHz) | P <sub>Mea</sub> (dBm) | P <sub>cl</sub> (dB) | Diatance | G <sub>a</sub> Antenna Gain(dB) | Peak EIRP (dBm) | Limit (dBm) | Margin (dB) | Polarization |
|-----------------|------------------------|----------------------|----------|---------------------------------|-----------------|-------------|-------------|--------------|
| 1401.0          | -46.23                 | 2.86                 | 3.00     | 7.25                            | -43.99          | -13.00      | 30.99       | H            |
| 2101.5          | -46.12                 | 2.94                 | 3.00     | 9.53                            | -41.68          | -13.00      | 28.68       | H            |
| 1401.0          | -45.78                 | 2.86                 | 3.00     | 7.25                            | -43.54          | -13.00      | 30.54       | V            |
| 2101.5          | -49.95                 | 2.94                 | 3.00     | 9.53                            | -45.51          | -13.00      | 32.51       | V            |

LTE FDD Band 12\_Channel Bandwidth 3MHz\_16QAM\_Middle Channel

| Frequency (MHz) | P <sub>Mea</sub> (dBm) | P <sub>cl</sub> (dB) | Diatance | G <sub>a</sub> Antenna Gain(dB) | EIRP (dBm) | Limit (dBm) | Margin (dB) | Polarization |
|-----------------|------------------------|----------------------|----------|---------------------------------|------------|-------------|-------------|--------------|
| 1415.0          | -46.75                 | 2.86                 | 3.00     | 7.25                            | -44.51     | -13.00      | 31.51       | H            |
| 2122.5          | -46.03                 | 2.94                 | 3.00     | 9.53                            | -41.59     | -13.00      | 28.59       | H            |
| 1415.0          | -45.73                 | 2.86                 | 3.00     | 7.25                            | -43.49     | -13.00      | 30.49       | V            |
| 2122.5          | -47.43                 | 2.94                 | 3.00     | 9.53                            | -42.99     | -13.00      | 29.99       | V            |

The results shown in this test report refer only to the sample(s) tested unless otherwise stated and the sample(s) are retained for 30 days only. The document is issued by HUAKE, this document cannot be reproduced except in full with our prior written permission. The more details and the authenticity of the report will be confirmed at <http://www.cer-mark.com>.

TEL : +86-755 2302 9901 FAX : +86-755 2302 9901 E-mail : service@cer-mark.com

Add: 1-2F., Building B2, Junfeng Zhongcheng Zhizao Innovation Park, Heping Community, Fuhai Street, Bao'an District, Shenzhen, Guangdong, China



LTE FDD Band 12\_Channel Bandwidth 3MHz\_16QAM\_High Channel

| Frequency (MHz) | P <sub>Mea</sub> (dBm) | P <sub>cl</sub> (dB) | Diatance | G <sub>a</sub> Antenna Gain(dB) | EIRP (dBm) | Limit (dBm) | Margin (dB) | Polarization |
|-----------------|------------------------|----------------------|----------|---------------------------------|------------|-------------|-------------|--------------|
| 1429.0          | -47.4                  | 2.86                 | 3.00     | 7.25                            | -45.16     | -13.00      | 32.16       | H            |
| 2143.5          | -43.81                 | 2.94                 | 3.00     | 9.53                            | -39.37     | -13.00      | 26.37       | H            |
| 1429.0          | -46.21                 | 2.86                 | 3.00     | 7.25                            | -43.97     | -13.00      | 30.97       | V            |
| 2143.5          | -49.89                 | 2.94                 | 3.00     | 9.53                            | -45.45     | -13.00      | 32.45       | V            |

LTE FDD Band 12\_Channel Bandwidth 5MHz\_16QAM\_Low Channel

| Frequency (MHz) | P <sub>Mea</sub> (dBm) | P <sub>cl</sub> (dB) | Diatance | G <sub>a</sub> Antenna Gain(dB) | Peak EIRP (dBm) | Limit (dBm) | Margin (dB) | Polarization |
|-----------------|------------------------|----------------------|----------|---------------------------------|-----------------|-------------|-------------|--------------|
| 1403.0          | -47.33                 | 2.86                 | 3.00     | 7.25                            | -45.09          | -13.00      | 32.09       | H            |
| 2104.5          | -44.1                  | 2.94                 | 3.00     | 9.53                            | -39.66          | -13.00      | 26.66       | H            |
| 1403.0          | -47.43                 | 2.86                 | 3.00     | 7.25                            | -45.19          | -13.00      | 32.19       | V            |
| 2104.5          | -48.47                 | 2.94                 | 3.00     | 9.53                            | -44.03          | -13.00      | 31.03       | V            |

LTE FDD Band 12\_Channel Bandwidth 5MHz\_16QAM\_Middle Channel

| Frequency (MHz) | P <sub>Mea</sub> (dBm) | P <sub>cl</sub> (dB) | Diatance | G <sub>a</sub> Antenna Gain(dB) | EIRP (dBm) | Limit (dBm) | Margin (dB) | Polarization |
|-----------------|------------------------|----------------------|----------|---------------------------------|------------|-------------|-------------|--------------|
| 1415.0          | -47.38                 | 2.86                 | 3.00     | 7.25                            | -45.14     | -13.00      | 32.14       | H            |
| 2122.5          | -43.78                 | 2.94                 | 3.00     | 9.53                            | -39.34     | -13.00      | 26.34       | H            |
| 1415.0          | -45.4                  | 2.86                 | 3.00     | 7.25                            | -43.16     | -13.00      | 30.16       | V            |
| 2122.5          | -49.27                 | 2.94                 | 3.00     | 9.53                            | -44.83     | -13.00      | 31.83       | V            |

LTE FDD Band 12\_Channel Bandwidth 5MHz\_16QAM\_High Channel

| Frequency (MHz) | P <sub>Mea</sub> (dBm) | P <sub>cl</sub> (dB) | Diatance | G <sub>a</sub> Antenna Gain(dB) | EIRP (dBm) | Limit (dBm) | Margin (dB) | Polarization |
|-----------------|------------------------|----------------------|----------|---------------------------------|------------|-------------|-------------|--------------|
| 1427.0          | -45.98                 | 2.86                 | 3.00     | 7.25                            | -43.74     | -13.00      | 30.74       | H            |
| 2140.5          | -46.19                 | 2.94                 | 3.00     | 9.53                            | -41.75     | -13.00      | 28.75       | H            |
| 1427.0          | -46.48                 | 2.86                 | 3.00     | 7.25                            | -44.24     | -13.00      | 31.24       | V            |
| 2140.5          | -50.06                 | 2.94                 | 3.00     | 9.53                            | -45.62     | -13.00      | 32.62       | V            |

LTE FDD Band 12\_Channel Bandwidth 10MHz\_16QAM\_Low Channel

| Frequency (MHz) | P <sub>Mea</sub> (dBm) | P <sub>cl</sub> (dB) | Diatance | G <sub>a</sub> Antenna Gain(dB) | Peak EIRP (dBm) | Limit (dBm) | Margin (dB) | Polarization |
|-----------------|------------------------|----------------------|----------|---------------------------------|-----------------|-------------|-------------|--------------|
| 1408.0          | -47.2                  | 2.86                 | 3.00     | 7.25                            | -44.96          | -13.00      | 31.96       | H            |
| 2112.0          | -44.38                 | 2.94                 | 3.00     | 9.53                            | -39.94          | -13.00      | 26.94       | H            |
| 1408.0          | -47.23                 | 2.86                 | 3.00     | 7.25                            | -44.99          | -13.00      | 31.99       | V            |
| 2112.0          | -47.42                 | 2.94                 | 3.00     | 9.53                            | -42.98          | -13.00      | 29.98       | V            |

LTE FDD Band 12\_Channel Bandwidth 10MHz\_16QAM\_Middle Channel

| Frequency (MHz) | P <sub>Mea</sub> (dBm) | P <sub>cl</sub> (dB) | Diatance | G <sub>a</sub> Antenna Gain(dB) | EIRP (dBm) | Limit (dBm) | Margin (dB) | Polarization |
|-----------------|------------------------|----------------------|----------|---------------------------------|------------|-------------|-------------|--------------|
| 1415.0          | -47.35                 | 2.86                 | 3.00     | 7.25                            | -45.11     | -13.00      | 32.11       | H            |
| 2122.5          | -44.01                 | 2.94                 | 3.00     | 9.53                            | -39.57     | -13.00      | 26.57       | H            |
| 1415.0          | -45.23                 | 2.86                 | 3.00     | 7.25                            | -42.99     | -13.00      | 29.99       | V            |
| 2122.5          | -49.1                  | 2.94                 | 3.00     | 9.53                            | -44.66     | -13.00      | 31.66       | V            |

The results shown in this test report refer only to the sample(s) tested unless otherwise stated and the sample(s) are retained for 30 days only. The document is issued by HUAKE, this document cannot be reproduced except in full with our prior written permission. The more details and the authenticity of the report will be confirmed at <http://www.cer-mark.com>.

TEL : +86-755 2302 9901 FAX : +86-755 2302 9901 E-mail : service@cer-mark.com

Add: 1-2F., Building B2, Junfeng Zhongcheng Zhizao Innovation Park, Heping Community, Fuhai Street, Bao'an District, Shenzhen, Guangdong, China



LTE FDD Band 12\_Channel Bandwidth 10MHz\_16QAM\_High Channel

| Frequency (MHz) | P <sub>Mea</sub> (dBm) | P <sub>cl</sub> (dB) | Diatance | G <sub>a</sub> Antenna Gain(dB) | EIRP (dBm) | Limit (dBm) | Margin (dB) | Polarization |
|-----------------|------------------------|----------------------|----------|---------------------------------|------------|-------------|-------------|--------------|
| 1422.0          | -44.7                  | 2.86                 | 3.00     | 7.25                            | -42.46     | -13.00      | 29.46       | H            |
| 2133.0          | -45.05                 | 2.94                 | 3.00     | 9.53                            | -40.61     | -13.00      | 27.61       | H            |
| 1422.0          | -45.8                  | 2.86                 | 3.00     | 7.25                            | -43.56     | -13.00      | 30.56       | V            |
| 2133.0          | -47.51                 | 2.94                 | 3.00     | 9.53                            | -43.07     | -13.00      | 30.07       | V            |

The results shown in this test report refer only to the sample(s) tested unless otherwise stated and the sample(s) are retained for 30 days only. The document is issued by HUAK, this document cannot be reproduced except in full with our prior written permission. The more details and the authenticity of the report will be confirmed at <http://www.cer-mark.com>.

TEL : +86-755 2302 9901 FAX : +86-755 2302 9901 E-mail : [service@cer-mark.com](mailto:service@cer-mark.com)

Add: 1-2F., Building B2, Junfeng Zhongcheng Zhizao Innovation Park, Heping Community, Fuhai Street, Bao'an District, Shenzhen, Guangdong, China

### 3.6 Frequency Stability Under Temperature & Voltage Variations

#### LIMIT

the frequency stability shall be sufficient to ensure that the fundamental emissions stay within the authorized bands of operation and should not exceed 2.5ppm.

#### TEST CONFIGURATION

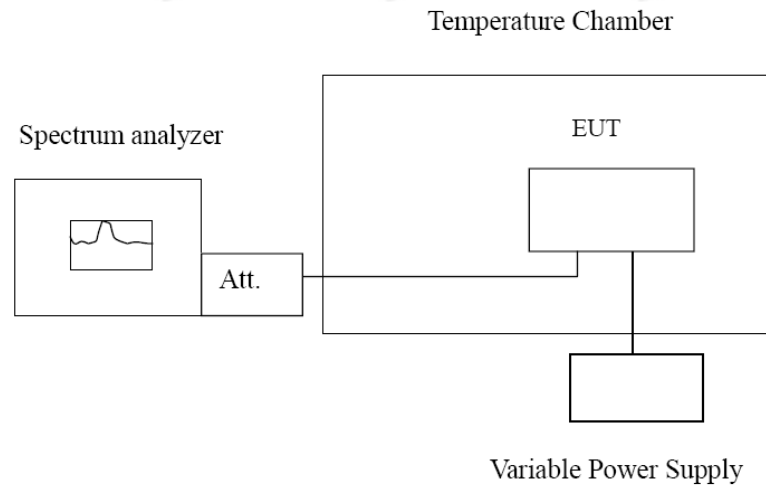

#### TEST PROCEDURE

The EUT was setup according to EIA/TIA 603D.

##### **Frequency Stability Under Temperature Variations:**

In order to measure the carrier frequency under the condition of AFC lock, it is necessary to make measurements with the EUT in a "call mode". This is accomplished with the use of R&S CMW500 DIGITAL RADIO COMMUNICATION TESTER.

1. Measure the carrier frequency at room temperature.
2. Subject the EUT to overnight soak at -30°C.
3. With the EUT, powered via nominal voltage, connected to the CMW500 and in a simulated call on middle channel for LTE band 12, measure the carrier frequency. These measurements should be made within 2 minutes of Powering up the EUT, to prevent significant self-warming.
4. Repeat the above measurements at 10°C increments from -30°C to +50°C. Allow at least 1.5 hours at each temperature, unpowered, before making measurements.
5. Re-measure carrier frequency at room temperature with nominal voltage. Vary supply voltage from minimum voltage to maximum voltage, in 0.1Volt increments re-measuring carrier frequency at each voltage. Pause at nominal voltage for 1.5 hours unpowered, to allow any self-heating to stabilize, before continuing.
6. Subject the EUT to overnight soak at +50°C.
7. With the EUT, powered via nominal voltage, connected to the CMW500 and in a simulated call on the centre channel, measure the carrier frequency. These measurements should be made within 2 minutes of Powering up the EUT, to prevent significant self-warming.
8. Repeat the above measurements at 10 °C increments from +50°C to -30°C. Allow at least 1.5 hours at each temperature, unpowered, before making measurements.
9. At all temperature levels hold the temperature to +/- 0.5°C during the measurement procedure.

##### **Frequency Stability Under Voltage Variations:**

Set chamber temperature to 20°C. Use a variable AC power supply / DC power source to power the EUT and set the voltage to rated voltage. Set the spectrum analyzer RBW low enough to obtain the desired frequency resolution and recorded the frequency.

Reduce the input voltage to specify extreme voltage variation ( $\pm 15\%$ ) and endpoint, record the maximum frequency change.



**TEST RESULTS**

Remark:

1. We tested all RB Configuration refer 3GPP TS136 521 for each Channel Bandwidth of LTE FDD Band 12; recorded worst case.

LTE Band 12, 1.4MHz bandwidth (worst case of all bandwidths)

**Frequency Error vs Voltage**

| Voltage (V) | Frequency error (Hz) |        | Frequency error (ppm) |           |
|-------------|----------------------|--------|-----------------------|-----------|
|             | QPSK                 | 16QAM  | QPSK                  | 16QAM     |
| 4.25V       | -14.15               | -34.89 | -0.020223             | -0.049864 |
| 5.0V        | -27.64               | -40.71 | -0.039503             | -0.058182 |
| 5.75V       | -37.29               | -43.97 | -0.053294             | -0.062841 |

**Frequency Error vs Temperature**

| Temperature (°C) | Frequency error (Hz) |        | Frequency error (ppm) |           |
|------------------|----------------------|--------|-----------------------|-----------|
|                  | QPSK                 | 16QAM  | QPSK                  | 16QAM     |
| -30°             | -44.60               | -47.06 | -0.063742             | -0.067257 |
| -20°             | -1.42                | 15.45  | -0.002029             | 0.021837  |
| -10°             | -10.11               | 11.22  | -0.014449             | 0.015859  |
| 0°               | -19.34               | 10.31  | -0.027640             | 0.014572  |
| 10°              | -27.39               | 10.36  | -0.039145             | 0.014643  |
| 20°              | -37.22               | 8.20   | -0.053194             | 0.011590  |
| 30°              | -10.93               | 7.75   | -0.015621             | 0.010954  |
| 40°              | -16.44               | 5.09   | -0.023496             | 0.007194  |
| 50°              | -22.20               | 4.16   | -0.031728             | 0.005880  |





## 4 TEST SETUP PHOTOS OF THE EUT

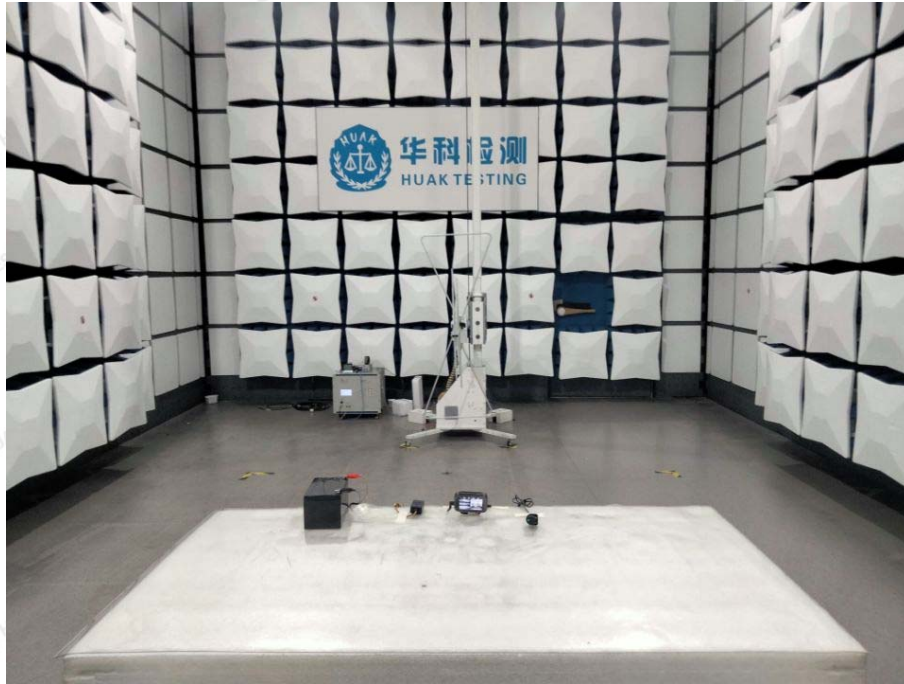

The results shown in this test report refer only to the sample(s) tested unless otherwise stated and the sample(s) are retained for 30 days only. The document is issued by HUAK, this document cannot be reproduced except in full with our prior written permission. The more details and the authenticity of the report will be confirmed at <http://www.cer-mark.com>.

TEL : +86-755 2302 9901 FAX : +86-755 2302 9901 E-mail : [service@cer-mark.com](mailto:service@cer-mark.com)

Addr: 1-2F., Building B2, Junfeng Zhongcheng Zhizao Innovation Park, Heping Community, Fuhai Street, Bao'an District, Shenzhen, Guangdong, China



## **5 PHOTOS OF THE EUT**

Reference to the report: ANNEX A of external photos and ANNEX B of internal photos.

.....**End of Report**.....