

<b>Prüfbericht-Nr.:</b> <i>Test report no.:</i>	CN23LS3G (P15C-BLE) 001	<b>Auftrags-Nr.:</b> <i>Order no.:</i>	48218061	Seite 1 von 27 Page 1 of 27
<b>Kunden-Referenz-Nr.:</b> <i>Client reference no.:</i>	N/A	<b>Auftragsdatum:</b> <i>Order date:</i>	2023-04-14	
<b>Auftraggeber:</b> <i>Client:</i>	DIGIMAX INNOVATIVE PRODUCTS LTD. 2F., No.196, Sec. 2, Zhong-Xing Road, Hsin-Tien City, Taiwan			
<b>Prüfgegenstand:</b> <i>Test item:</i>	Mimitakara hearing aid (with charging box)			
<b>Bezeichnung / Typ-Nr.:</b> <i>Identification / Type no.:</i>	DP-6EF, UP-6EF			
<b>Auftrags-Inhalt:</b> <i>Order content:</i>	FCC Part 15C Test report (BLE)			
<b>Prüfgrundlage:</b> <i>Test specification:</i>	FCC 47CFR Part 15: Subpart C Section 15.247			
<b>Wareneingangsdatum:</b> <i>Date of sample receipt:</i>	2023-04-18			
<b>Prüfmuster-Nr.:</b> <i>Test sample no.:</i>	A003458504-001 A003458504-002 & 004 & 005			
<b>Prüfzeitraum:</b> <i>Testing period:</i>	2023-05-03 - 2023-05-18			
<b>Ort der Prüfung:</b> <i>Place of testing:</i>	EMC/RF Taipei Testing Site			
<b>Prüflaboratorium:</b> <i>Testing laboratory:</i>	Taipei Testing Laboratories			
<b>Prüfergebnis*:</b> <i>Test result*:</i>	Pass			
<b>zusammengestellt von:</b> <i>compiled by:</i>	<b>genehmigt von:</b> <i>authorized by:</i>			
<b>Datum:</b> <i>Date:</i> 2023-05-31	 Ethan Shao		<b>Ausstellungsdatum:</b> <i>Issue date:</i> 2023-05-31	
<b>Stellung / Position:</b>	Assistant Project Engineer		 Brenda Chen Senior Project Manager	
<b>Sonstiges / Other:</b>				
<b>Zustand des Prüfgegenstandes bei Anlieferung:</b> <i>Condition of the test item at delivery:</i>		Prüfmuster vollständig und unbeschädigt <i>Test item complete and undamaged</i>		
* Legende:	1 = sehr gut P(ass) = entspricht o.g. Prüfgrundlage(n)	2 = gut 3 = befriedigend F(ail) = entspricht nicht o.g. Prüfgrundlage(n)	4 = ausreichend N/A = nicht anwendbar	5 = mangelhaft N/T = nicht getestet
* Legend:	1 = very good P(ass) = passed a.m. test specification(s)	2 = good 3 = satisfactory F(ail) = failed a.m. test specification(s)	4 = sufficient N/A = not applicable	5 = poor N/T = not tested
<b>Dieser Prüfbericht bezieht sich nur auf das o.g. Prüfmuster und darf ohne Genehmigung der Prüfstelle nicht auszugsweise vervielfältigt werden. Dieser Bericht berechtigt nicht zur Verwendung eines Prüfzeichens.</b> <i>This test report only relates to the a. m. test sample. Without permission of the test center this test report is not permitted to be duplicated in extracts. This test report does not entitle to carry any test mark.</i>				

## TEST SUMMARY

Report Section	FCC Clause	Test Item	Result
5.1.1	15.247(b) & 15.203	Antenna Requirement	Pass
5.1.2	15.247(b)(3)	Peak Output Power	Pass
5.1.3	15.247(a)(2)	6 dB Bandwidth	Pass
5.1.3	2.1049	99% Occupied Bandwidth	Pass
5.1.4	15.247(e)	Power Spectral Density	Pass
5.1.5	15.247(d)	Conducted Spurious Emissions and Band Edges	Pass
5.1.6	15.247(d) & 15.205 & 15.209	Radiated Spurious Emissions and Band Edges	Pass
5.2.1	15.207	Mains Conducted Emission	Pass

**Note:** Determining compliance based on the results of the compliance measurement, not taking into account measurement instrumentation uncertainty.

## Contents

<b>HISTORY OF THIS TEST REPORT .....</b>	<b>5</b>
<b>1. GENERAL REMARKS .....</b>	<b>6</b>
<b>1.1 COMPLEMENTARY MATERIALS.....</b>	<b>6</b>
<b>1.2 DECISION RULE OF CONFORMITY .....</b>	<b>6</b>
<b>2. TEST SITES .....</b>	<b>7</b>
<b>2.1 TEST LABORATORY .....</b>	<b>7</b>
<b>2.2 TEST FACILITY.....</b>	<b>7</b>
<b>2.3 TRACEABILITY .....</b>	<b>8</b>
<b>2.4 CALIBRATION .....</b>	<b>8</b>
<b>2.5 MEASUREMENT UNCERTAINTY .....</b>	<b>8</b>
<b>3. GENERAL PRODUCT INFORMATION.....</b>	<b>9</b>
<b>3.1 PRODUCT FUNCTION AND INTENDED USE .....</b>	<b>9</b>
<b>3.2 SYSTEM DETAILS AND RATINGS.....</b>	<b>9</b>
<b>3.3 NOISE GENERATING AND NOISE SUPPRESSING PARTS .....</b>	<b>10</b>
<b>3.4 SUBMITTED DOCUMENTS.....</b>	<b>10</b>
<b>4. TEST SET-UP AND OPERATION MODES.....</b>	<b>11</b>
<b>4.1 PRINCIPLE OF CONFIGURATION SELECTION .....</b>	<b>11</b>
<b>4.2 CARRIER FREQUENCY AND CHANNEL.....</b>	<b>11</b>
<b>4.3 TEST OPERATION AND TEST SOFTWARE.....</b>	<b>12</b>
<b>4.4 SPECIAL ACCESSORIES AND AUXILIARY EQUIPMENT .....</b>	<b>13</b>
<b>4.5 TEST SETUP DIAGRAM .....</b>	<b>14</b>
<b>5. TEST RESULTS .....</b>	<b>15</b>
<b>5.1 TRANSMITTER REQUIREMENT &amp; TEST SUITES .....</b>	<b>15</b>
5.1.1 <i>Antenna Requirement .....</i>	<i>15</i>
5.1.2 <i>Peak Output Power .....</i>	<i>16</i>
5.1.3 <i>6 dB Bandwidth and 99% Occupied Bandwidth.....</i>	<i>18</i>
5.1.4 <i>Power Spectral Density.....</i>	<i>19</i>
5.1.5 <i>Conducted Spurious Emissions and Frequency Band Edges Measured in 100kHz Bandwidth.....</i>	<i>20</i>
5.1.6 <i>Radiated Spurious Emissions and Band Edges .....</i>	<i>21</i>
<b>5.2 MAINS EMISSION .....</b>	<b>26</b>
5.2.1 <i>Mains Conducted Emission.....</i>	<i>26</i>

**Prüfbericht - Nr.: CN23LS3G (P15C-BLE) 001**  
Test Report No.

Seite 4 von 27  
Page 4 of 27

**APPENDIX A - TEST RESULT OF CONDUCTED**

**APPENDIX B - TEST RESULT OF RADIATED EMISSIONS & MAINS CONDUCTED EMISSION**

**APPENDIX SP - PHOTOGRAPHS OF TEST SETUP**

**APPENDIX EP - PHOTOGRAPHS OF EUT**

**Prüfbericht - Nr.: CN23LS3G (P15C-BLE) 001**  
Test Report No.

Seite 5 von 27  
Page 5 of 27

## HISTORY OF THIS TEST REPORT

Report No.	Description	Date Issued
CN23LS3G (P15C-BLE) 001	Original Release	2023-05-31

## 1. General Remarks

### 1.1 Complementary Materials

All attachments are integral parts of this test report. This applies especially to the following appendix:

**Appendix A - Test Result of Conducted**

**Appendix B - Test Result of Radiated Emissions & Mains Conducted Emission**

**Appendix SP - Photographs of Test Setup**

**Appendix EP - Photographs of EUT**

### Applied Standard and Test Levels

Radio
FCC 47CFR Part 15: Subpart C Section 15.247
FCC 47CFR Part 2: Subpart J Section 2.1049
ANSI C63.10:2013
KDB 558074 D01 15.247 Meas Guidance v05r02

### 1.2 Decision Rule of Conformity

The decision rule of conformity of this test report is following the requirements of the requested standard in the quotation, and agreed among testing laboratory and manufacturer (applicant) to exclude the consideration of Measurement Uncertainty, unless it is required by the specific standard.

## 2. Test Sites

### 2.1 Test Laboratory

Taipei Testing Laboratories

11F. No.758, Sec. 4, Bade Rd., Songshan Dist.  
Taipei City 105  
Taiwan (R.O.C.)

### 2.2 Test Facility

Taipei Testing Laboratories

No.458-18, Sec. 2, Fenliao Rd., Linkou Dist.,  
New Taipei City 244  
Taiwan (R.O.C.)  
FCC Registration No.: 180491  
ISED Registration No.: 25563

## 2.3 Traceability

All measurement equipment calibrations are traceable to NML(Taiwan)/NIST(USA) or where calibration is performed outside Taiwan, to equivalent nationally recognized standards organizations.

## 2.4 Calibration

Equipment requiring calibration is calibrated periodically in a suitably accredited Calibration Lab. Additionally all equipment is verified for proper performance on a regular basis using in house standards or comparisons.

## 2.5 Measurement Uncertainty

All measurement uncertainty values are shown with a coverage factor of  $k=2$  to indicate a 95% level of confidence.

### Emission Measurement Uncertainty

Parameter	Uncertainty
Radiated Emission (9 kHz ~ 30 MHz)	$\pm 1.15$ dB
Radiated Emission (30 MHz ~ 200 MHz)	$\pm 1.30$ dB
Radiated Emission (200 MHz ~ 1 GHz)	$\pm 1.30$ dB
Radiated Emission (1 GHz ~ 18 GHz)	$\pm 1.54$ dB
Radiated Emission (18 GHz ~ 40 GHz)	$\pm 2.52$ dB
Mains Conducted Emission	$\pm 1.65$ dB



### 3. General Product Information

#### 3.1 Product Function and Intended Use

The EUT is a Mimitakara hearing aid (with charging box). It contains a Bluetooth compatible module enabling the user to communicate data through a Wireless interface.

For details refer to the User Guide, Data Sheet and Circuit Diagram.

#### 3.2 System Details and Ratings

##### Basic Information of EUT

Item	EUT information
Kind of Equipment/Test Item	Mimitakara hearing aid (with charging box)
Type Identification	DP-6EF, UP-6EF
FCC ID	2BBAZ-6EFX

##### Technical Specification of EUT

Item	EUT information
Operating Frequency	2402 MHz ~ 2480 MHz
Channel Number	40
Data Rate	1Mbps, 2Mbps
Operation Voltage	3.7 Vdc
Modulation	GFSK
Maximum Output Power (mW)	2.81
Antenna Information	Refer to 5.1.1
Accessory Device	Refer to 4.4

Note:

- All models are listed as below.

Main Model	Series Model	Difference
DP-6EF	UP-6EF	All models are electrically identical, different model names are for marketing purpose.

### **3.3 Noise Generating and Noise Suppressing Parts**

Refer to the Circuit Diagram.

### **3.4 Submitted Documents**

- Circuit Diagram
- Instruction Manual
- Rating Label
- Technical Description

## 4. Test Set-up and Operation Modes

### 4.1 Principle of Configuration Selection

The test modes were adapted accordingly in reference to the instructions for use.

During testing, Channel and Power Controlling Software provided by the customer was used to control the operating channel as well as the output power level. The RF output power selection is for the setting of RF output expected by the customer and is going to be fixed on the firmware of the final end product.

#### Table for Parameters of Test Software Setting

Frequency (MHz)	Power Setting
2402	0x04
2440	0x04
2480	0x04

### 4.2 Carrier Frequency and Channel

Channel	Freq. (MHz)	Channel	Freq. (MHz)	Channel	Freq. (MHz)	Channel	Freq. (MHz)
0	2402	10	2422	20	2442	30	2462
1	2404	11	2424	21	2444	31	2464
2	2406	12	2426	22	2446	32	2466
3	2408	13	2428	23	2448	33	2468
4	2410	14	2430	24	2450	34	2470
5	2412	15	2432	25	2452	35	2472
6	2414	16	2434	26	2454	36	2474
7	2416	17	2436	27	2456	37	2476
8	2418	18	2438	28	2458	38	2478
9	2420	19	2440	29	2460	39	2480

### 4.3 Test Operation and Test Software

Setup for testing: Test samples are provided with fixture interface which makes it possible to control them through a test software installed on a notebook computer.  
 This software was running on the laptop computer connected to the EUT. It was used to enable the operation modes listed as below.

Test Software	AWRDLABV2(1.0.9.8)
---------------	--------------------

The samples were used as follows:

A003458504-001

A003458504-002 & 004 & 005

Full test was applied on all test modes, but only worst case was shown.

EUT Configure Mode	Applicable To			Description	
	Antenna Port Conducted Measurement	Radiated Spurious Emissions above 1 GHz	Radiated Spurious Emissions below 1 GHz		Mains Conducted Emission
-	√	√	√	√	-

Note:

1. The EUT had been pre-tested on the positioned of each 3 axis. The worst case was found when position on **Z-plane** for EUT standalone mode and **Y-plane** for EUT with charger box mode.
2. "-" means no effect.

#### Antenna Port Conducted Measurement

Pre-Scan full test was applied on all test modes, but only worst case was shown.

Following channel(s) was (were) selected for the final test as listed below.

EUT Configure Mode	Available Frequency (MHz)	Tested Frequency (MHz)	Date Rate (Mbps)
-	2402 to 2480	2402, 2440, 2480	1
-	2402 to 2480	2402, 2440, 2480	2

#### Radiated Spurious Emissions (Above 1 GHz)

Pre-Scan full test was applied on all test modes, but only worst case was shown.

Following channel(s) was (were) selected for the final test as listed below.

EUT Configure Mode	Available Frequency (MHz)	Tested Frequency (MHz)	Date Rate (Mbps)
EUT Standalone	2402 to 2480	2402, 2440, 2480	1
	2402 to 2480	2402, 2440, 2480	2

#### Radiated Spurious Emissions (Below 1 GHz)

Pre-Scan full test was applied on all test modes, but only worst case was shown.

Following channel(s) was (were) selected for the final test as listed below.

EUT Configure Mode	Available Frequency (MHz)	Tested Frequency (MHz)	Date Rate (Mbps)
EUT Standalone	2402 to 2480	2480	2
EUT with charger box	EUT with all RF functions		

#### Mains Conducted Emission

Pre-Scan full test was applied on all test modes, but only worst case was shown.

Following channel(s) was (were) selected for the final test as listed below.

EUT Configure Mode	Description
EUT with charger box	EUT with all RF functions

**Test Condition**

Test Item	Ambient Temperature	Relative Humidity	Tested by
Conducted Measurement	23.3-24.2 °C	49.9-59.6 %	Andy Chen
Radiated Spurious Emissions above 1 GHz	22.5-24.8 °C	53-56 %	Chuan Chu & Ivan Chiang
Radiated Spurious Emissions below 1 GHz	22.5-24.8 °C	53-56 %	Chuan Chu & Ivan Chiang
Mains Conducted Emission	21.1-24.9 °C	51.7-54.9 %	Ray Huang

## 4.4 Special Accessories and Auxiliary Equipment

The product has been tested together with the following additional accessories:

**Accessory of EUT**

No.	Product	Brand	Model	Description
-	Battery	Varta	Varta	3.7 Vdc
A	USB Cable	JUN YU LINK LIMITED	R14A1009I1	--
-	Charger Box	Mimitakara	DP-6EF Charging box	--

**Support Unit**

Support Unit								
No	Description	Brand	Model	S/N	Shielded	Ferrite Core (Qty)	Length (cm)	Remark
B	Fixture Cable	Compal	N/A	N/A	N/A	N/A	20	--
1	Adapter	OPPO	VC56JACH	N/A	-	-	-	--
2	NB	HP	Laptop-15s-du0xx	N/A	-	-	-	--

### 4.5 Test Setup Diagram

<Radiated Spurious Emissions mode>  
 EUT Standalone

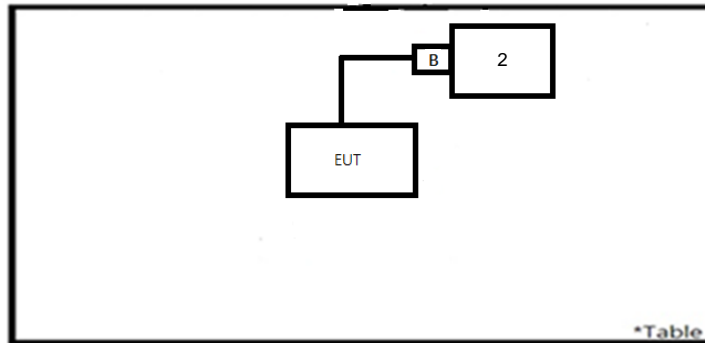

EUT with Charger box

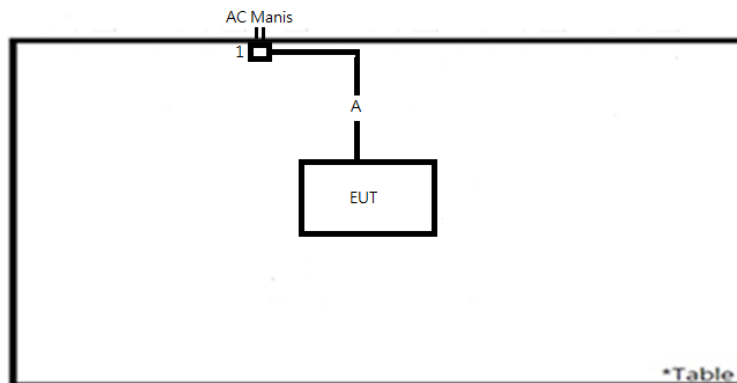

<Mains Conducted Emission mode>

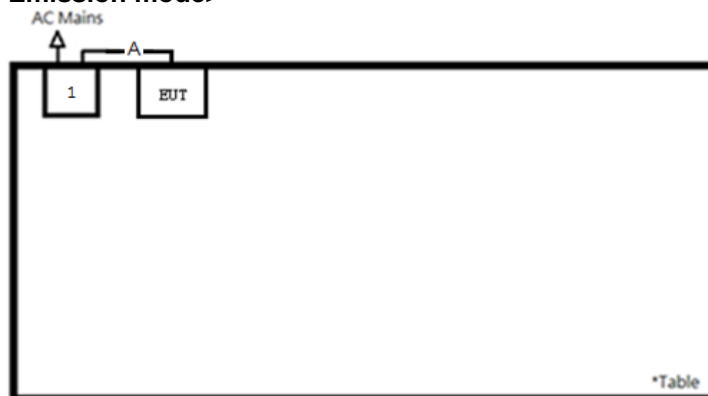

## 5. Test Results

### 5.1 Transmitter Requirement & Test Suites

#### 5.1.1 Antenna Requirement

**Requirement** Use of approved antennas only

According to the manufacturer declaration, the EUT has an antenna with a directional gain of 2 dBi. The antenna is a chip antenna with no possibility of replacement with a non-approved antenna by the end-user. Therefore, the EUT is considered to comply with this provision.

Refer to EUT photo for details.

### 5.1.2 Peak Output Power

**Limit** 1 watt (30 dBm)

**Kind of Test Site** Shielded room

**Test Setup**

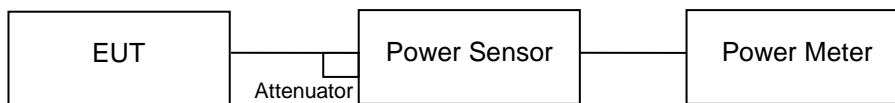

**Test Instruments**

Kind of Equipment	Manufacturer	Type	S/N	Calibration Date	Calibration Due Date	Test Date	
						From	Until
Power Meter	Anritsu	ML2495A	1901008	2023/3/17	2024/3/15	2023/5/3	2023/5/18
Power Sensor	Anritsu	MA2411B	1725269	2023/3/17	2024/3/15	2023/5/3	2023/5/18

**Test Procedures**

A peak power sensor was used on the output port of the EUT. A power meter was used to read the response of the peak power sensor. Record the power level.

Average power sensor was used to perform output power measurement, trigger and gating function of wide band power meter is enabled to measure max output power of TX on burst. Duty factor is not added to measured value.



**Test Result**
**Peak Output Power**
**<1Mbps>**

Channel	Channel Frequency	Peak Output Power		Limit (dBm)
	(MHz)	(dBm)	(mW)	
Low Channel	2402	4.36	2.73	30
Middle Channel	2440	4.43	2.77	30
High Channel	2480	4.46	2.79	30

**<2Mbps>**

Channel	Channel Frequency	Peak Output Power		Limit (dBm)
	(MHz)	(dBm)	(mW)	
Low Channel	2402	4.38	2.74	30
Middle Channel	2440	4.44	2.78	30
High Channel	2480	4.49	2.81	30

**Average Power (For Reference)**
**<1Mbps>**

Channel	Channel Frequency	Average Power	
	(MHz)	(dBm)	(mW)
Low Channel	2402	4.20	2.63
Middle Channel	2440	4.27	2.67
High Channel	2480	4.33	2.71

**<2Mbps>**

Channel	Channel Frequency	Average Power	
	(MHz)	(dBm)	(mW)
Low Channel	2402	4.21	2.64
Middle Channel	2440	4.28	2.68
High Channel	2480	4.34	2.72

### 5.1.3 6 dB Bandwidth and 99% Occupied Bandwidth

**Limit** The minimum 6 dB bandwidth shall be at least 500 kHz.

**Kind of Test Site** Shielded room

#### Test Setup

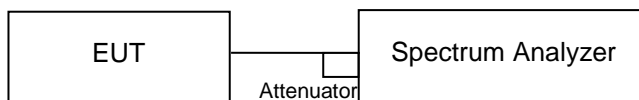

#### Test Instruments

Kind of Equipment	Manufacturer	Type	S/N	Calibration Date	Calibration Due Date	Test Date	
						From	Until
Spectrum Analyzer	R&S	FSV	101512	2023/2/23	2024/2/22	2023/5/3	2023/5/18

#### Test Procedure

- a. Set resolution bandwidth (RBW) = 100 kHz
- b. Set the video bandwidth (VBW)  $\geq 3 \times$  RBW, Detector = Peak.
- c. Trace mode = max hold.
- d. Sweep = auto couple.
- e. Measure the maximum width of the emission that is constrained by the frequencies associated with the two amplitude points (upper and lower) that are attenuated by 6 dB relative to the maximum level measured in the fundamental emission.
- f. For 99% occupied bandwidth measurement, the transmitter output was connected to the spectrum analyzer through an attenuator. The bandwidth of the fundamental frequency was measured by spectrum analyzer with resolution bandwidth in the range of 1% to 5% of the anticipated emission bandwidth, and a video bandwidth at least 3x the resolution bandwidth and set the detector to PEAK. The width of a frequency band such that, below the lower and above the upper frequency limits, the mean powers emitted are each equal to a specified percentage 0.5% of the total mean power of a given emission.

#### Test Results

Please refer to Appendix A.

### 5.1.4 Power Spectral Density

**Limit**

The power spectral density shall not be greater than 8 dBm in any 3 kHz band.

**Kind of Test Site**                      Shielded room

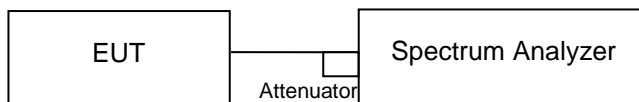
**Test Setup**

**Test Instruments**

Kind of Equipment	Manufacturer	Type	S/N	Calibration Date	Calibration Due Date	Test Date	
						From	Until
Spectrum Analyzer	R&S	FSV	101512	2023/2/23	2024/2/22	2023/5/3	2023/5/18

**Test Procedure**

- a. Set analyzer center frequency to DTS channel center frequency.
- b. Set the span to 1.5 times the DTS bandwidth.
- c. Set the RBW to:  $3 \text{ kHz} \leq \text{RBW} \leq 100 \text{ kHz}$ .
- d. Set the VBW  $\geq 3 \times \text{RBW}$ .
- e. Detector = peak.
- f. Sweep time = auto couple.
- g. Trace mode = max hold.
- h. Allow trace to fully stabilize.
- i. Use the peak marker function to determine the maximum amplitude level within the RBW.

**Test Results**

Please refer to Appendix A.

### 5.1.5 Conducted Spurious Emissions and Frequency Band Edges Measured in 100kHz Bandwidth

**Limit**

20dB (below that in the 100 kHz bandwidth within the band that contains the highest level of the desired power.)

**Kind of Test Site**                      Shielded room

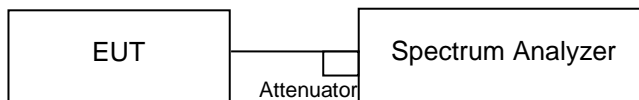
**Test Setup**

**Test Instruments**

Kind of Equipment	Manufacturer	Type	S/N	Calibration Date	Calibration Due Date	Test Date	
						From	Until
Spectrum Analyzer	R&S	FSV	101512	2023/2/23	2024/2/22	2023/5/3	2023/5/18

**Test Procedure**

Measurement procedure REF

1. Set the RBW = 100 kHz.
2. Set the VBW  $\geq$  300 kHz.
3. Detector = peak.
4. Sweep time = auto couple.
5. Trace mode = max hold.
6. Allow trace to fully stabilize.
7. Use the peak marker function to determine the maximum power level in any 100 kHz band segment within the fundamental EBW.

Measurement procedure OOBE

1. Set RBW = 100 kHz.
2. Set VBW  $\geq$  300 kHz.
3. Detector = peak.
4. Sweep = auto couple.
5. Trace Mode = max hold.
6. Allow trace to fully stabilize.
7. Use the peak marker function to determine the maximum amplitude level.

**Test Results**

Please refer to Appendix A.

## 5.1.6 Radiated Spurious Emissions and Band Edges

### Limit

Radiated emissions which fall in the restricted bands, as defined in §15.205(a), must comply with the radiated emission limits specified in §15.209(a).

Emissions radiated outside the restricted and authorized frequency bands must either comply with the radiated emission limits specified for the restricted bands or in §15.247(d).

**Kind of Test Site**                      3m Semi-Anechoic Chamber

### Test Setup

**<Radiated Emissions below 30 MHz>**

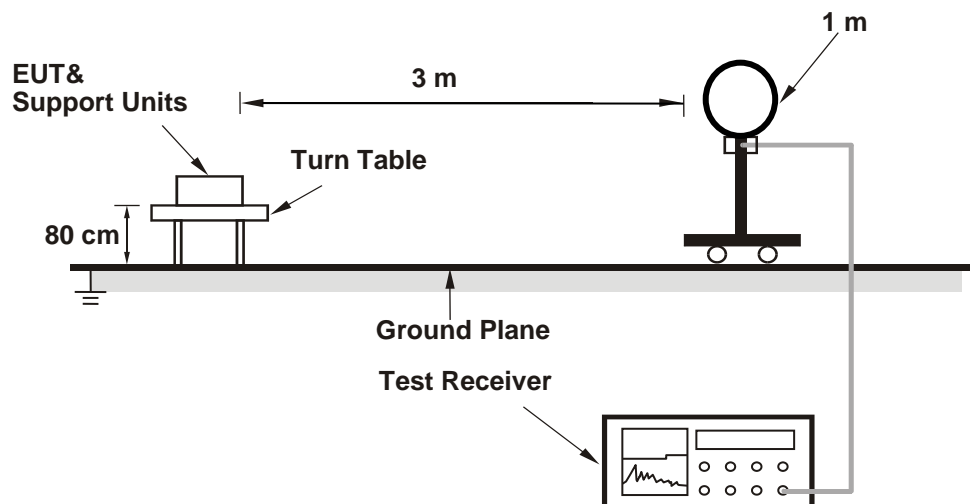

**<Radiated Emissions 30 MHz to 1 GHz>**

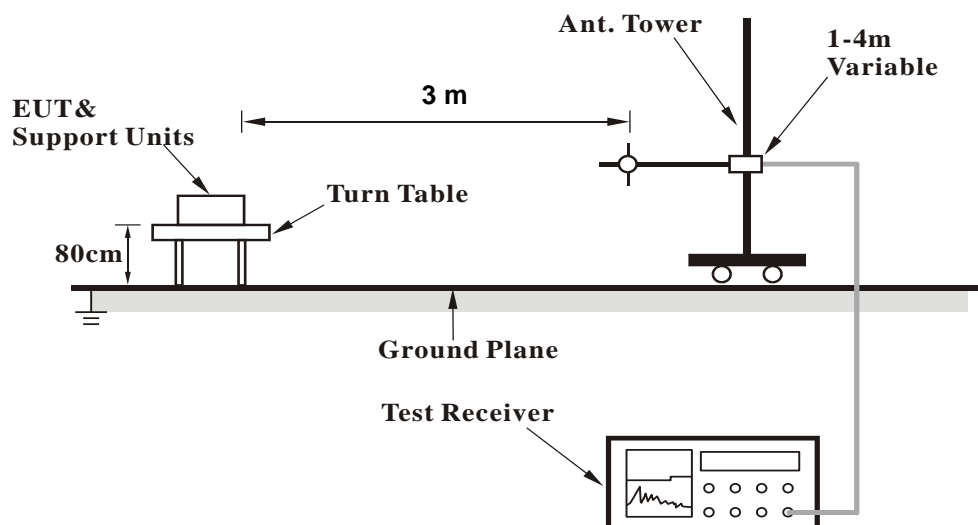

## &lt;Radiated Emissions above 1 GHz&gt;

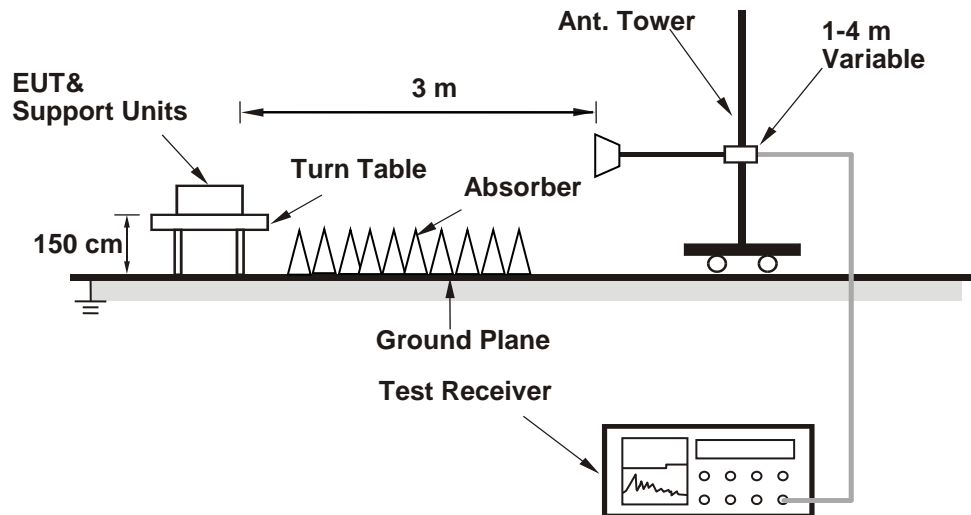

For the actual test configuration, please refer to the attached file (Test Setup Photo).

**Test Instruments**

Kind of Equipment	Manufacturer	Type	S/N	Calibration Date	Calibration Due Date
<b>Above 1 GHz</b>					
Signal Analyzer	R&S	FSV40	101508	2023/4/20	2024/4/18
Horn Antenna	ETS-Lindgren	3117	00218929	2022/12/8	2023/12/7
HF-AMP + AC source	EMCI	EMC051845SE	980633	2023/2/22	2024/2/21
HF-AMP + AC source	EMCI	EMC184045SE	980657	2023/2/16	2024/2/15
Horn Antenna	SCHWARZBECK	BBHA 9170	00887	2023/3/31	2024/3/29
Test Software	Audix E3	15914a_20191106 tuv	PK-001087	N/A	N/A
<b>30 MHz ~ 1 GHz</b>					
Receiver	R&S	ESR7	102109	2023/2/24	2024/2/23
Bilog Antenna	SCHWARZBECK	VULB-9168	00951	2023/3/31	2024/3/29
LF-AMP	Agilent	8447D	2944A107722	2023/3/22	2024/3/20
Test Software	Audix E3	15914a_20191106 tuv	PK-001087	N/A	N/A
<b>Below 30 MHz</b>					
Receiver	R&S	ESR7	102109	2023/2/24	2024/2/23
Loop Antenna	SCHWARZBECK	FMZB 1519B	00215	2023/1/4	2024/1/3
Test Software	Audix E3	15914a_20191106 tuv	PK-001087	N/A	N/A

**Test Procedures****For Radiated Emissions below 30 MHz**

- a. The EUT was placed on the top of a rotating table 0.8 meters above the ground at a 3 meter chamber room. The table was rotated 360 degrees to determine the position of the highest radiation.
- b. The EUT was set 3 meters away from the interference-receiving antenna, which was mounted on the top of a variable-height antenna tower.
- c. Parallel (OPEN), perpendicular (CLOSE), and ground-parallel (GROUND) orientations of the antenna are set to make the measurement.
- d. For each suspected emission, the EUT was arranged to its worst case and the rotatable table was turned from 0 degrees to 360 degrees to find the maximum reading.
- e. The test-receiver system was set to Quasi-Peak Detect Function and Specified Bandwidth with Maximum Hold Mode.

## Note:

1. The resolution bandwidth and video bandwidth of test receiver/spectrum analyzer is 9 kHz at frequency below 30 MHz.
2. All modes of operation were investigated and the worst-case emissions are reported.

**For Radiated Emissions above 30 MHz**

- a. The EUT was placed on the top of a rotating table 0.8 meters (for 30 MHz ~ 1 GHz) / 1.5 meters (for above 1 GHz) above the ground at 3 meter chamber room for test. The table was rotated 360 degrees to determine the position of the highest radiation.
- b. The EUT was set 3 meters away from the interference-receiving antenna, which was mounted on the top of a variable-height antenna tower.
- c. The height of antenna is varied from one meter to four meters above the ground to determine the maximum value of the field strength. Both horizontal and vertical polarizations of the antenna are set to make the measurement.
- d. For each suspected emission, the EUT was arranged to its worst case and then the antenna was tuned to heights from 1 meter to 4 meters and the rotatable table was turned from 0 degrees to 360 degrees to find the maximum reading.
- e. The test-receiver system was set to quasi-peak detect function and specified bandwidth with maximum hold mode when the test frequency is below 1 GHz.
- f. The test-receiver system was set to peak and average detected function and specified bandwidth with maximum hold mode when the test frequency is above 1 GHz. If the peak reading value also meets average limit, measurement with the average detector is unnecessary.

## Note:

1. The resolution bandwidth and video bandwidth of test receiver/spectrum analyzer is 120 kHz for Quasi-peak detection (QP) or Peak detection (PK) at frequency below 1 GHz.
2. The resolution bandwidth of test receiver/spectrum analyzer is 1 MHz and the video bandwidth is 3 MHz for Peak detection (PK) at frequency above 1 GHz.
3. The resolution bandwidth of test receiver/spectrum analyzer is 1 MHz and the video bandwidth is  $\geq 1/T$  (Duty cycle < 98 %) or 10 Hz (Duty cycle  $\geq 98$  %) for Average detection (AV) at frequency above 1 GHz.
4. All modes of operation were investigated and the worst-case emissions are reported.
5. The Radiated Emissions testing was performed in the X(E1), Y(H) and Z(E2) axis orientation. The worst-case Axis orientation is recorded in this test report.



**Prüfbericht - Nr.:**      **CN23LS3G (P15C-BLE) 001**  
*Test Report No.*

**Seite 25 von 27**  
*Page 25 of 27*

**Test Results**

Factor (dB/m) = Antenna Factor (dB/m) + Cable Loss (dB)  
Level (dBuV/m) = Reading (dBuV) + Factor (dB/m)

Please refer to Appendix B.

## 5.2 Mains Emission

### 5.2.1 Mains Conducted Emission

#### Limit

Mains Conducted Emission as defined in §15.207 must comply with the mains conducted emission limits.

**Kind of Test Site**                      Shielded room

#### Test Setup

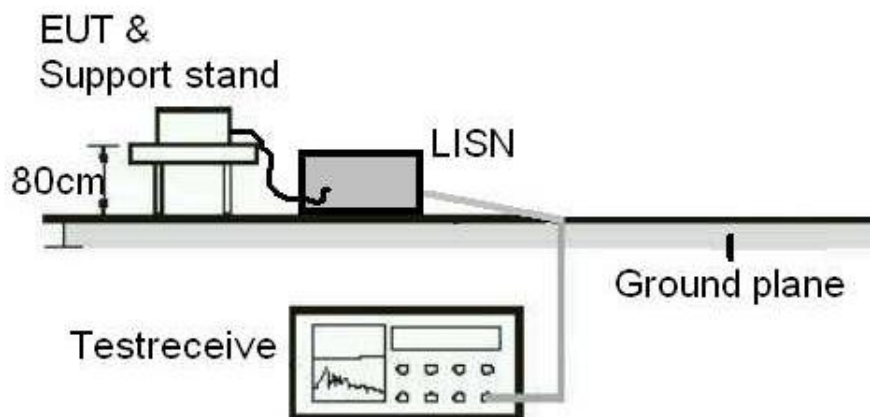

#### Test Instruments

Kind of Equipment	Manufacturer	Type	S/N	Calibration Date	Calibration Due Date
Two-Line V-Network	Rohde & Schwarz	ENV216	101938	2022/9/22	2023/9/21
EMI Test Receiver	R&S	ESCI	100797	2022/6/19	2023/6/18

#### **Test Procedures**

- a. The EUT was placed 0.4 meters from the conducting wall of the shielded room with EUT being connected to the power mains through a line impedance stabilization network (LISN). Other support units were connected to the power mains through another LISN. The two LISNs provide 50 ohm/50 uH of coupling impedance for the measuring instrument.
- b. Both lines of the power mains connected to the EUT were checked for maximum conducted interference.
- c. The frequency range from 150 kHz to 30 MHz was searched. Emission levels under (Limit – 20 dB) was not recorded.

Note: The resolution bandwidth and video bandwidth of test receiver is 9 kHz for quasi-peak detection (QP) and average detection (AV) at frequency 0.15 MHz – 30 MHz.

#### **Test Results**

Please refer to Appendix B.

## Appendix A: Test Results of Conducted Test

### Test Result of 6 dB Bandwidth

**BLE\_1M**

Channel	Channel Frequency (MHz)	6 dB Bandwidth (MHz)	Limit (MHz)	Result
Low Channel	2402	0.67	> 0.5	Pass
Middle Channel	2440	0.67	> 0.5	Pass
High Channel	2480	0.67	> 0.5	Pass

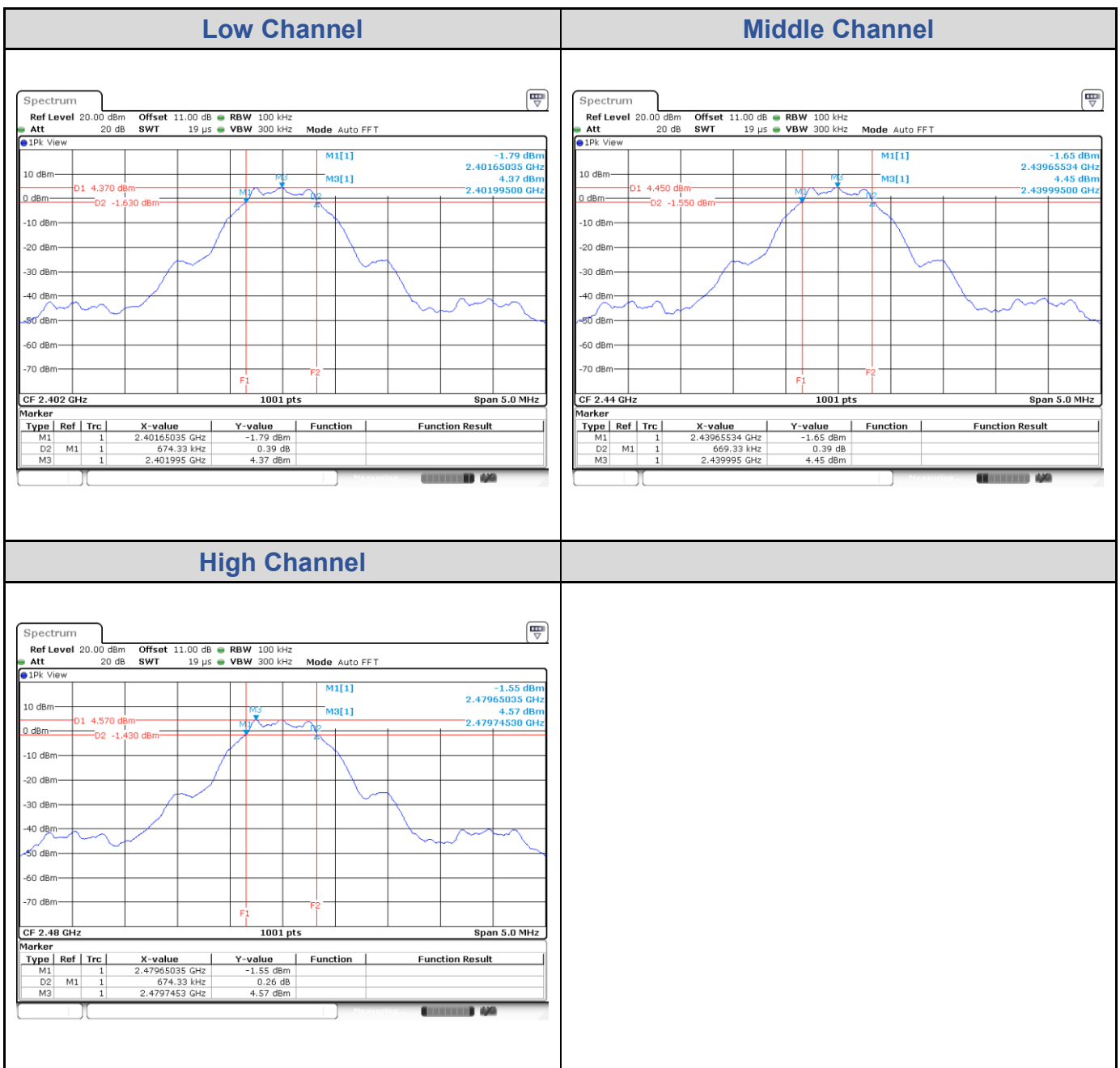

**BLE\_2M**

Channel	Channel Frequency (MHz)	6 dB Bandwidth (MHz)	Limit (MHz)	Result
Low Channel	2402	1.39	> 0.5	Pass
Middle Channel	2440	1.39	> 0.5	Pass
High Channel	2480	1.38	> 0.5	Pass

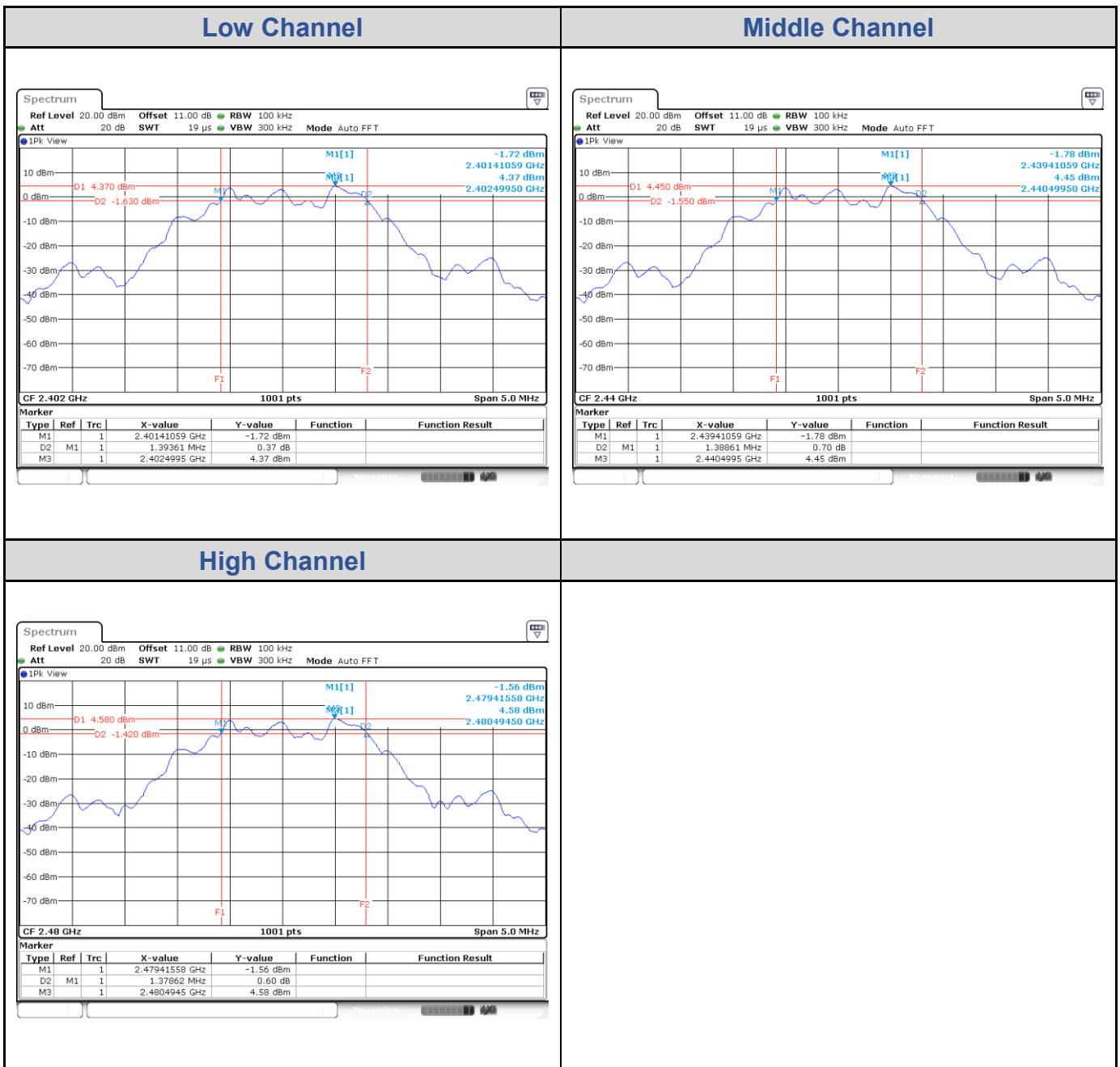

**Test Result of 99% Occupied Bandwidth**
**BLE\_1M**

Channel	Channel Frequency (MHz)	99% Bandwidth (MHz)
Low Channel	2402	1.03
Middle Channel	2440	1.03
High Channel	2480	1.03

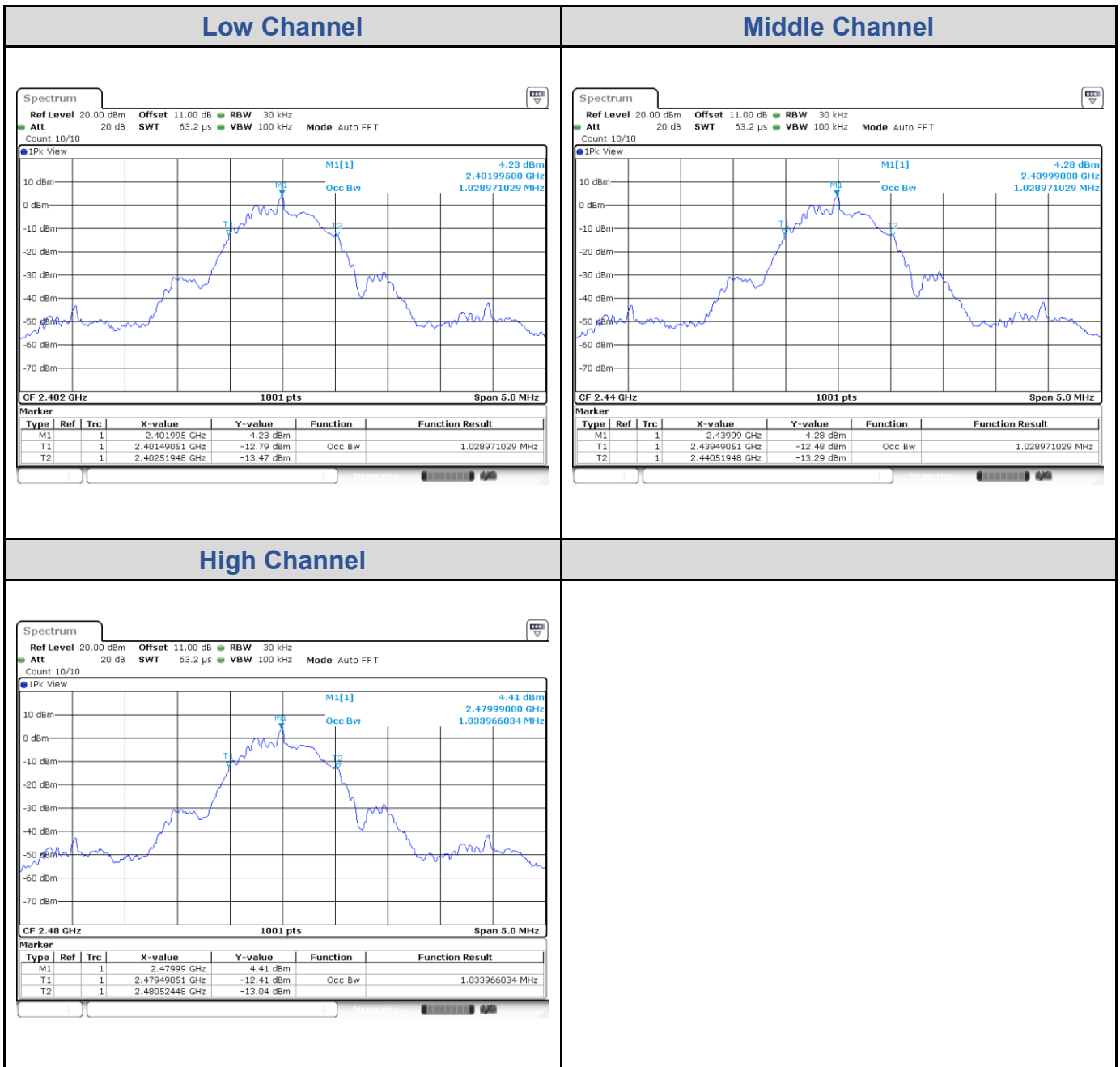

**BLE\_2M**

Channel	Channel Frequency (MHz)	99% Bandwidth (MHz)
Low Channel	2402	2.02
Middle Channel	2440	2.02
High Channel	2480	2.02

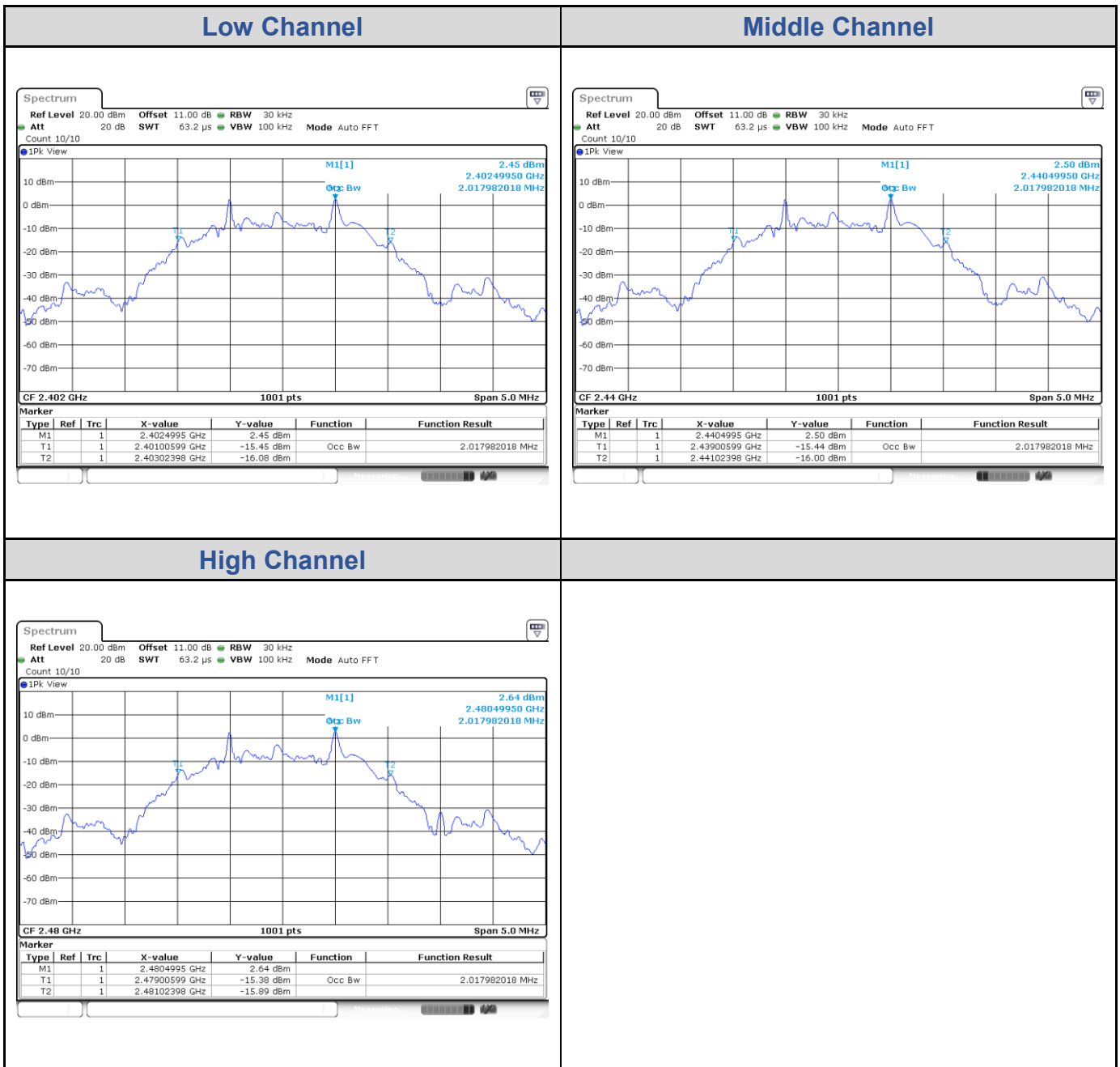

## Test Result of Power Spectral Density

### BLE\_1M

Channel	Channel Frequency (MHz)	Power Density (dBm)	Limit (dBm)	Result
Low Channel	2402	-9.08	8	Pass
Middle Channel	2440	-8.93	8	Pass
High Channel	2480	-8.92	8	Pass

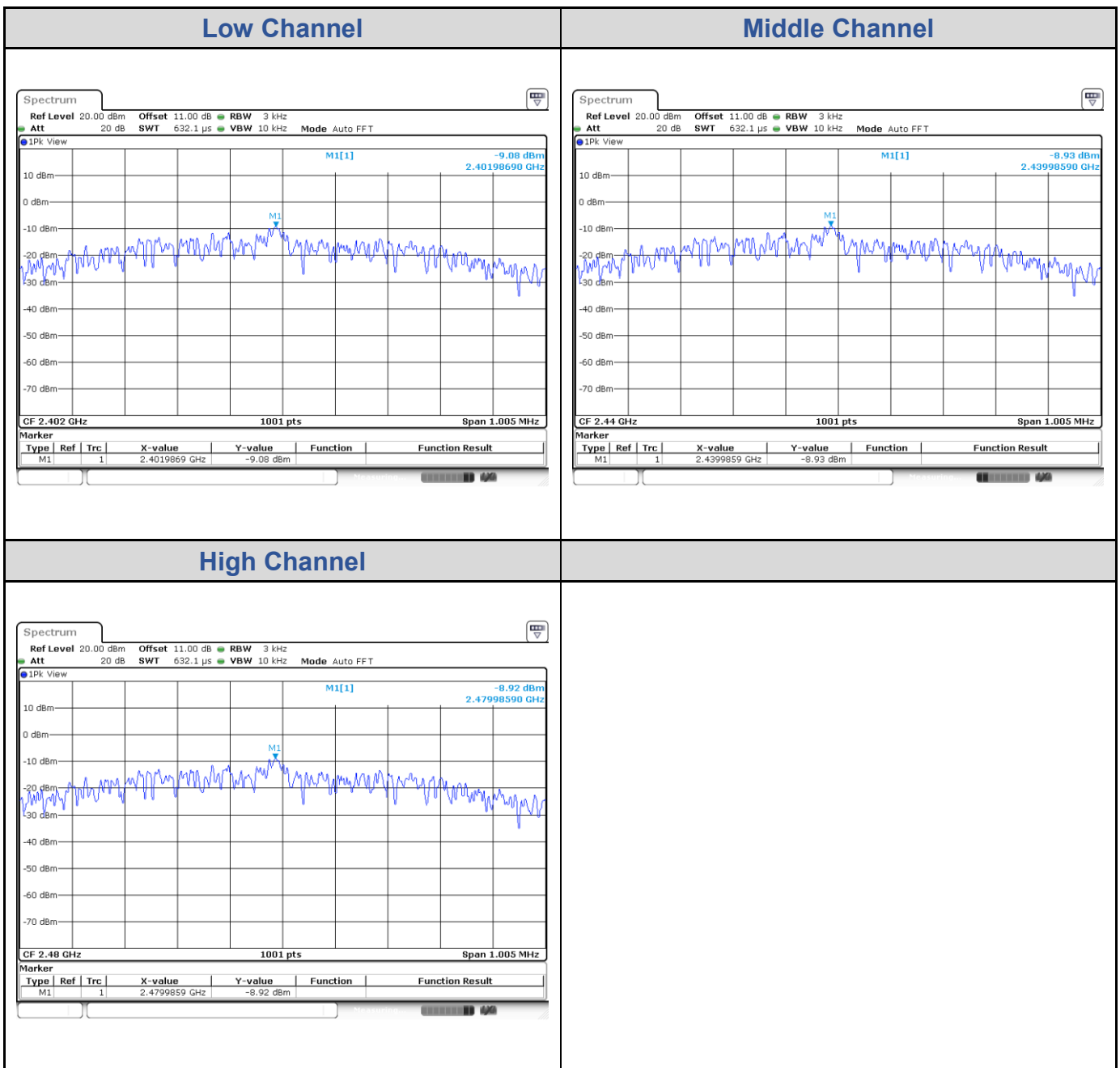



**BLE\_2M**

Channel	Channel Frequency (MHz)	Power Density (dBm)	Limit (dBm)	Result
Low Channel	2402	-2.84	8	Pass
Middle Channel	2440	-2.69	8	Pass
High Channel	2480	-2.47	8	Pass

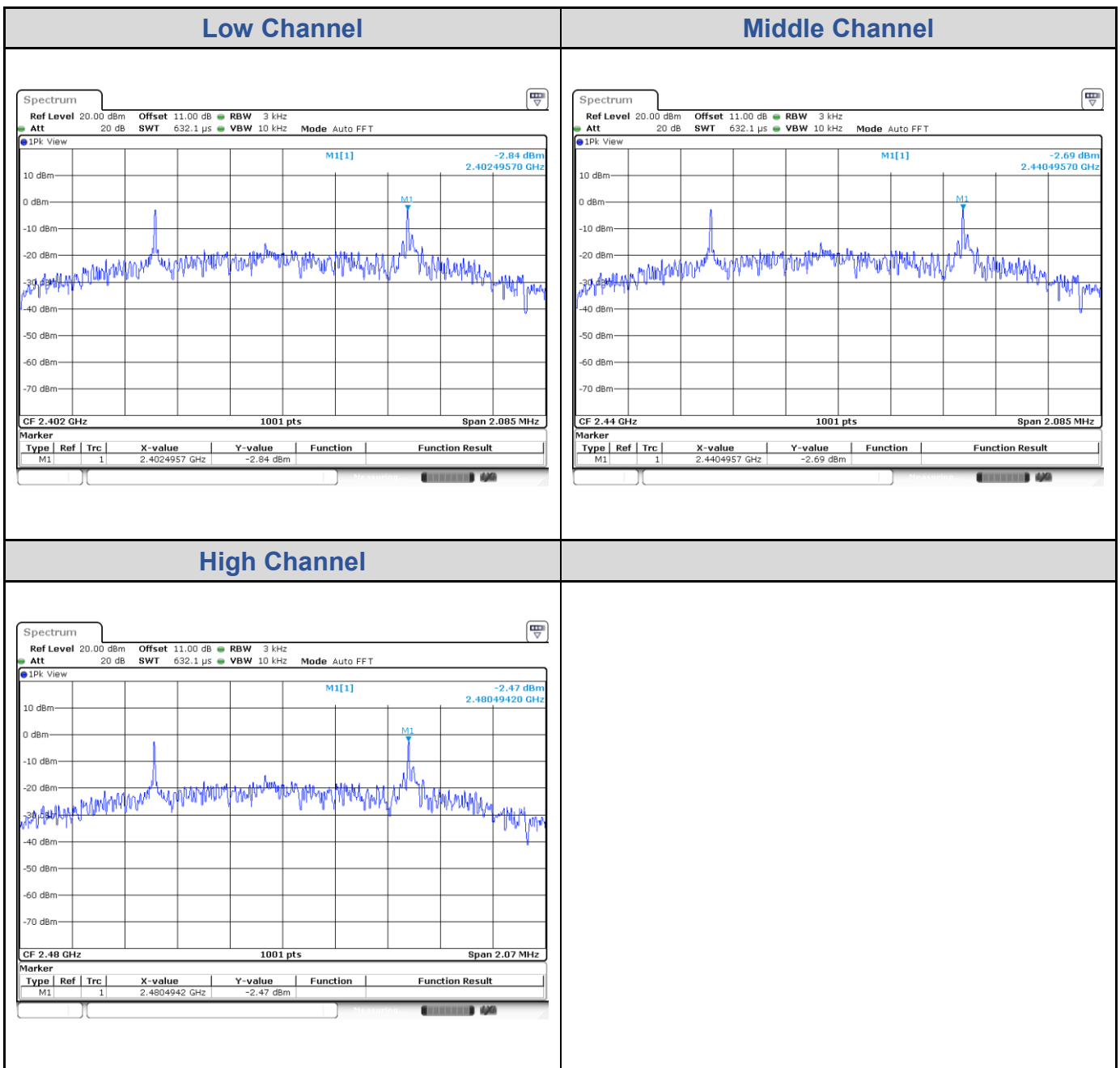

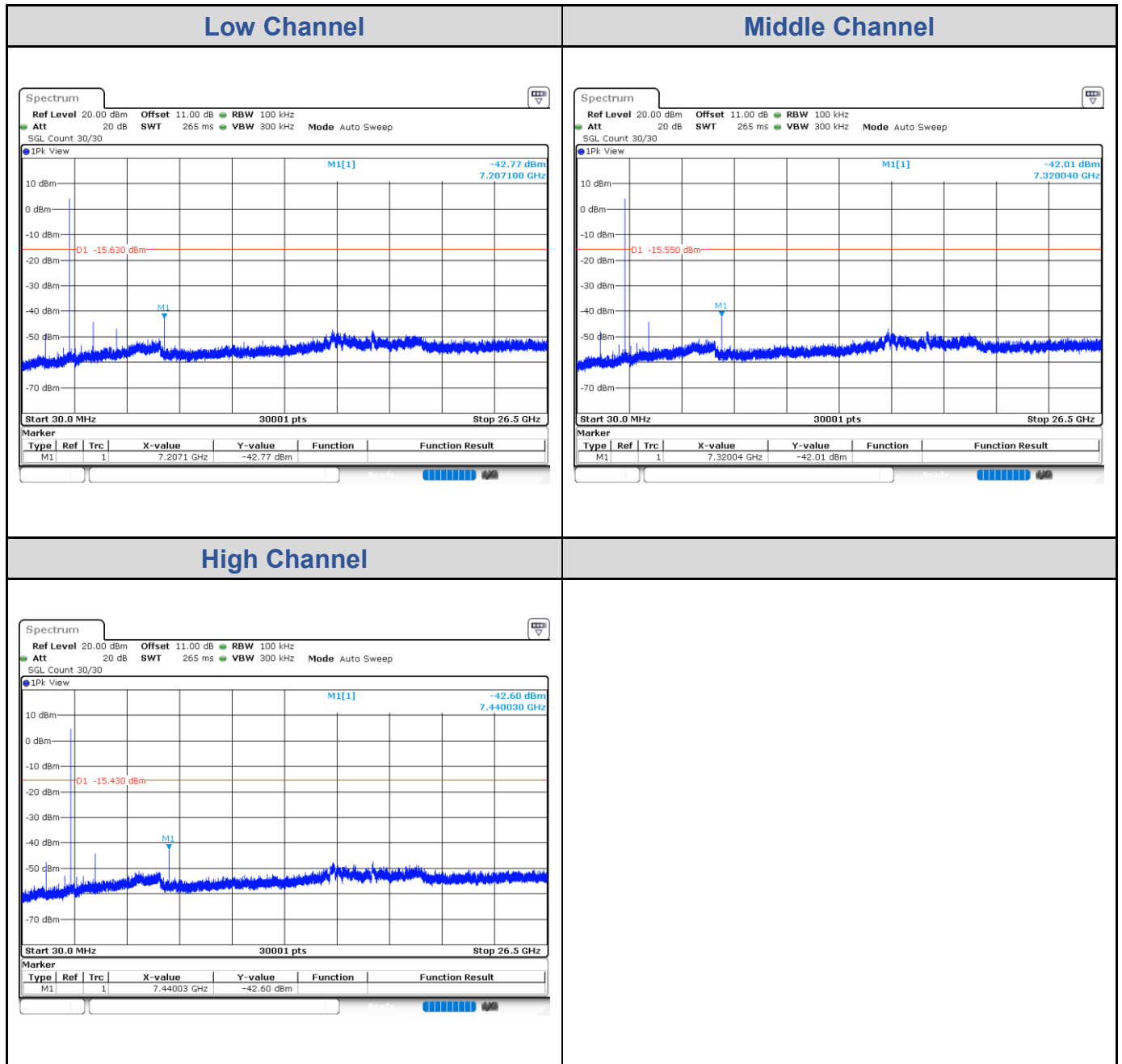
**Test Result of Conducted Spurious Emissions, Tx Mode**
**BLE\_1M**

BLE\_2M

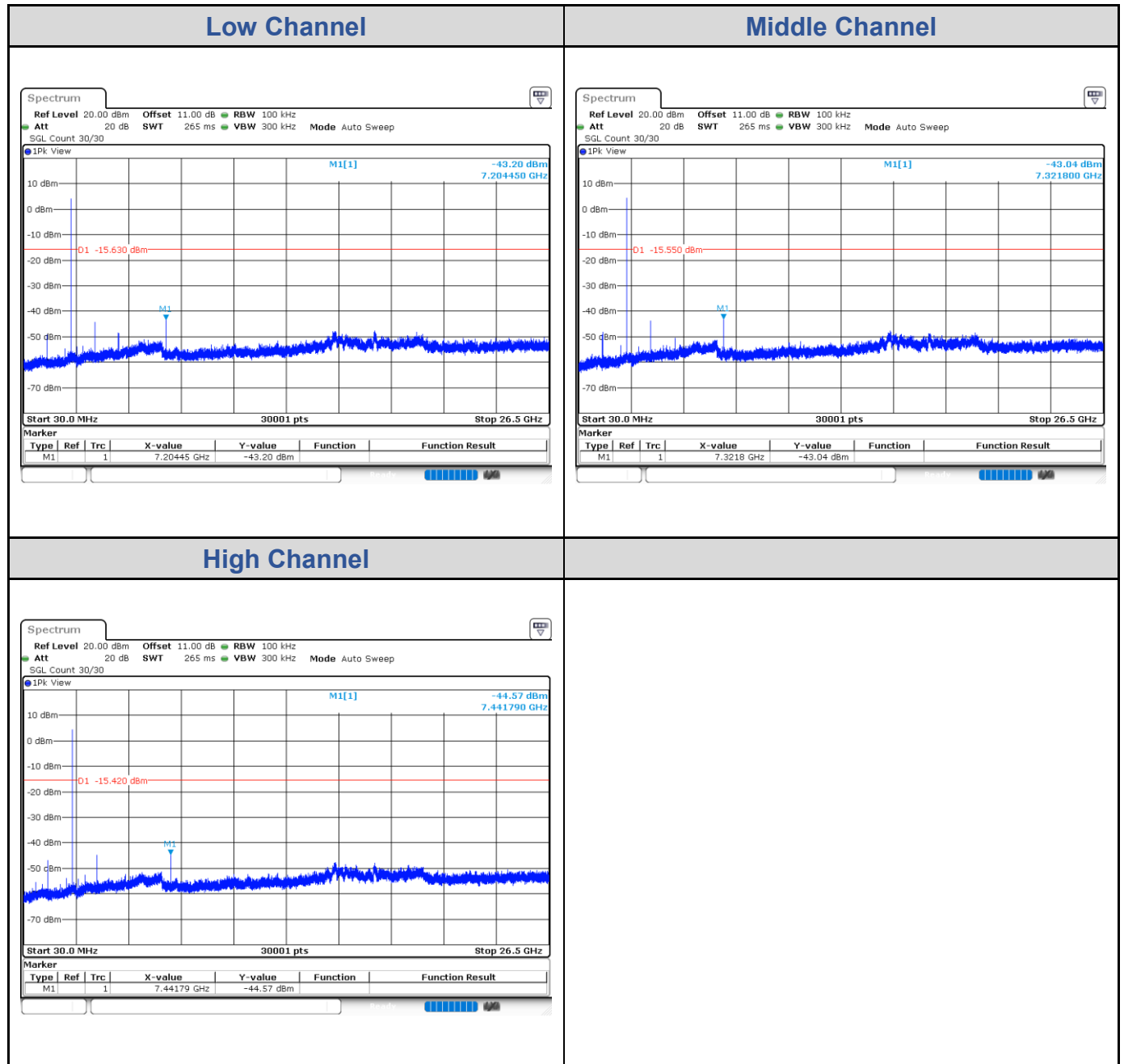

## Test Result of Conducted Band Edge, Tx Mode

### BLE\_1M

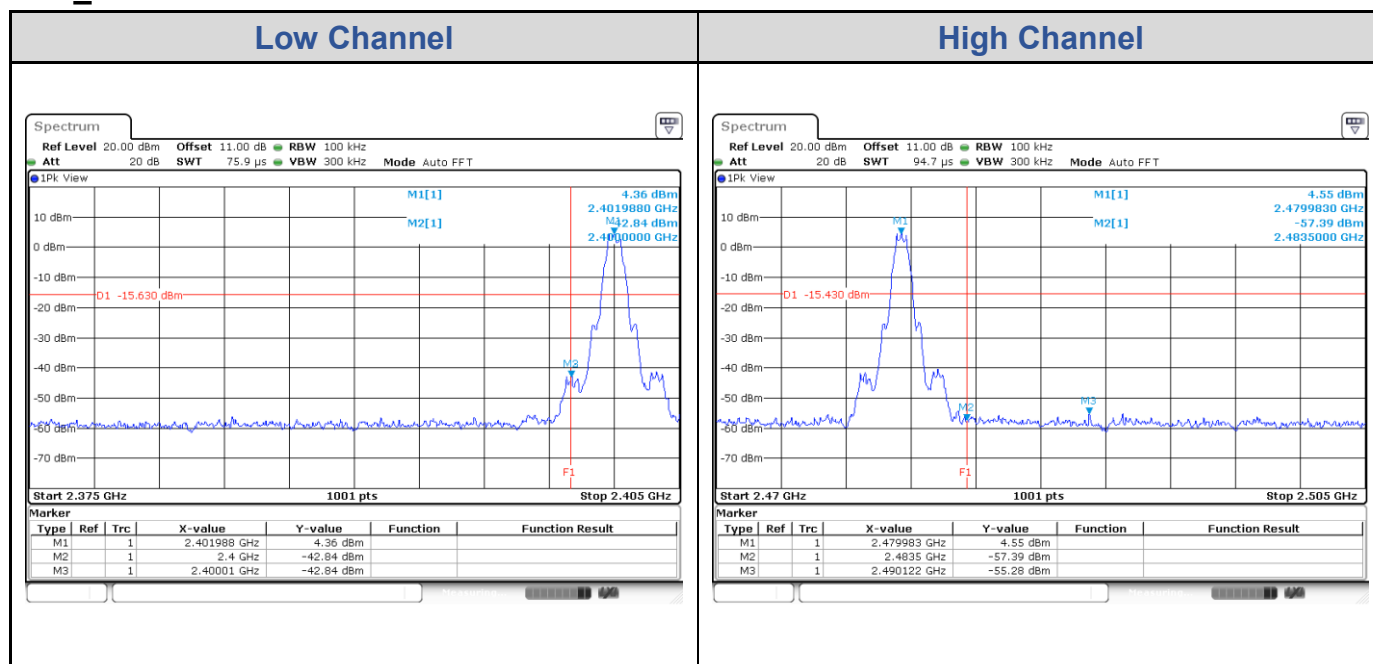

### BLE\_2M

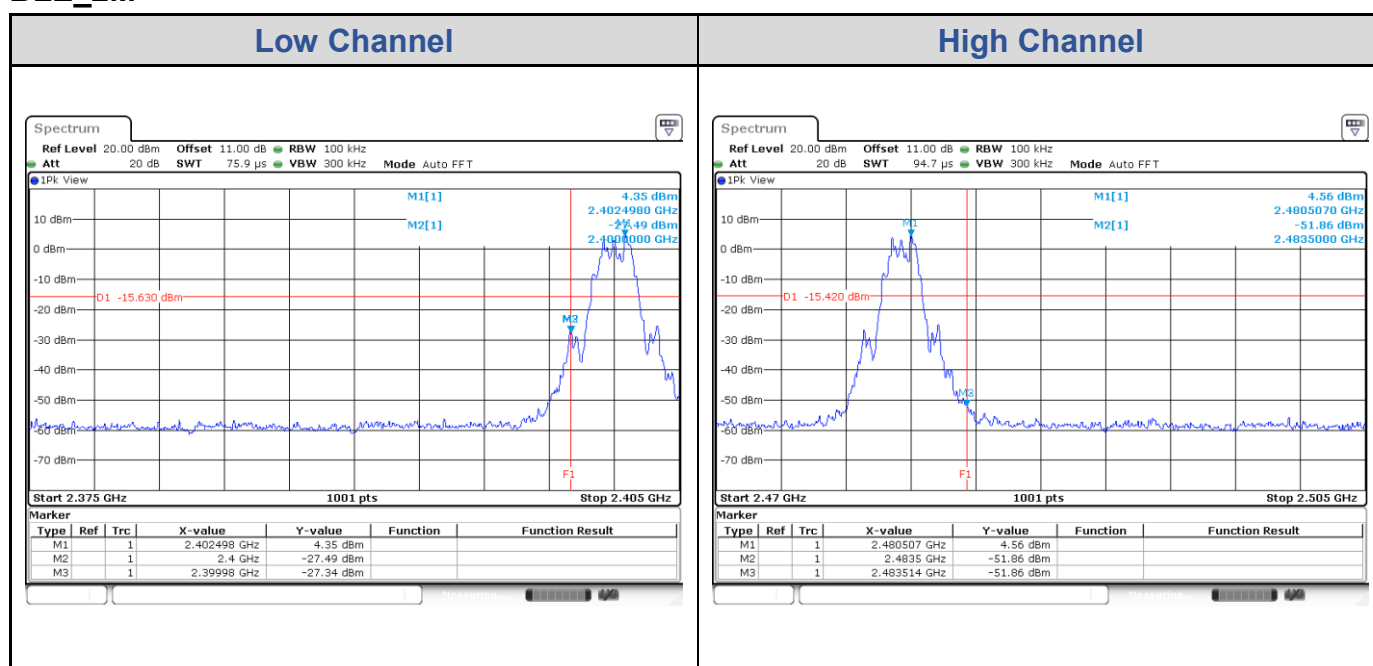

# Appendix B: Test Results of Radiated Spurious Emissions & Mains

## Conducted Emission Test

<EUT Standalone>

Band Edges, 2.31GHz ~ 2.9GHz

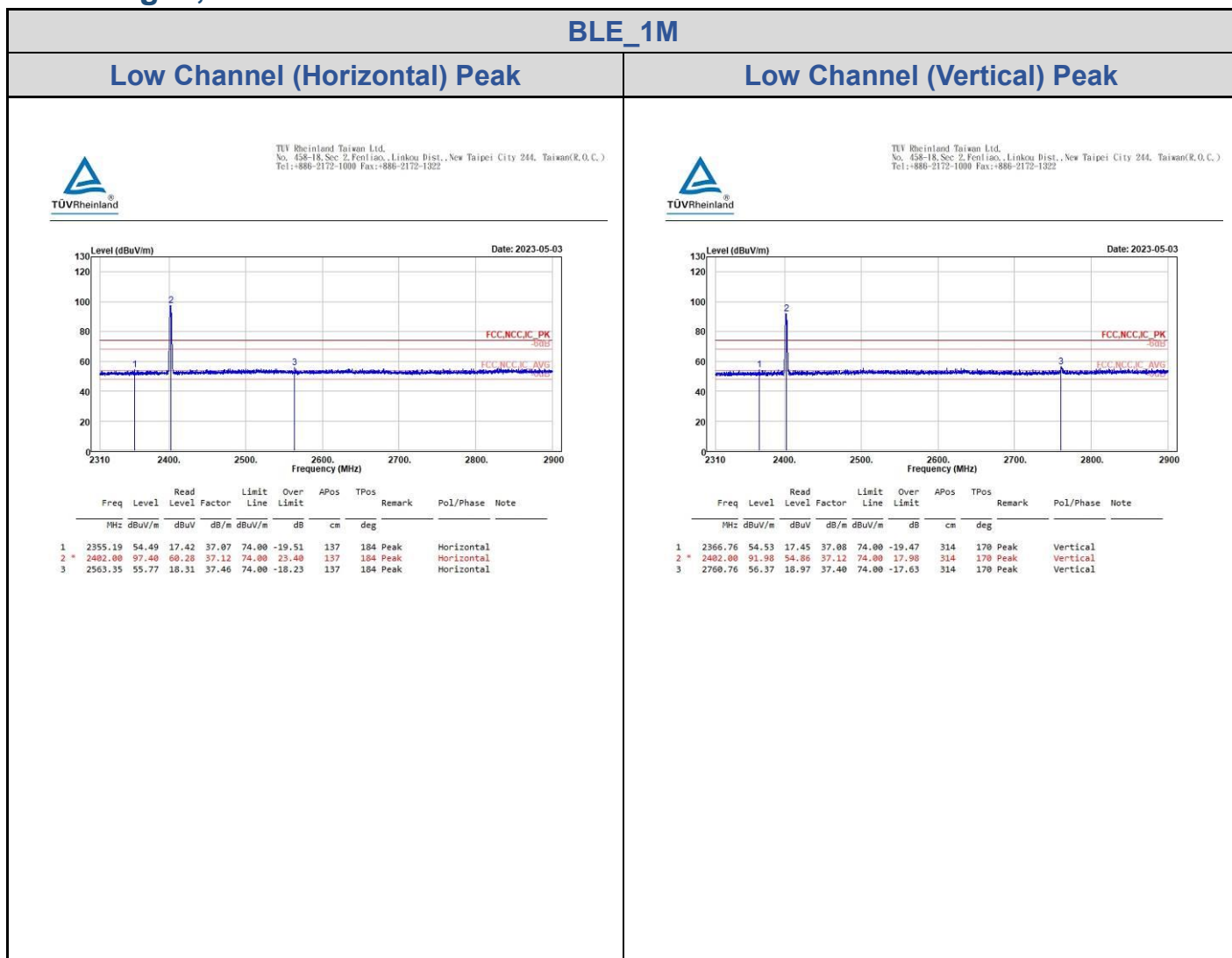

BLE\_1M

Low Channel (Horizontal) Average

Low Channel (Vertical) Average



TUV Rheinland Taiwan Ltd.  
No. 458-18, Sec 2, Fenliao, Linkou Dist., New Taipei City 244, Taiwan(R.O.C.)  
Tel: +886-2172-1000 Fax: +886-2172-1322

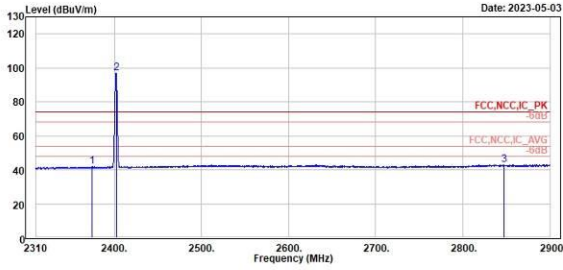

Freq	Level	Read	Limit	Over	APos	TPos	Remark	Pol/Phase	Note
MHz	dBuV/m	dBuV	dB/m	dBuV/m	dB	cm	deg		
1	2374.43	41.88	4.88	37.88	54.00	-12.12	137	184 Average	Horizontal
2 *	2482.00	96.96	59.84	37.12	54.00	42.96	137	184 Average	Horizontal
3	2847.25	43.16	5.46	37.78	54.00	-10.84	137	184 Average	Horizontal



TUV Rheinland Taiwan Ltd.  
No. 458-18, Sec 2, Fenliao, Linkou Dist., New Taipei City 244, Taiwan(R.O.C.)  
Tel: +886-2172-1000 Fax: +886-2172-1322

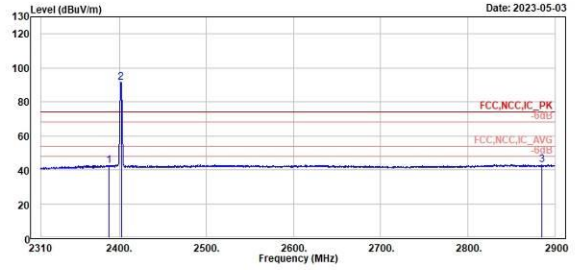

Freq	Level	Read	Limit	Over	APos	TPos	Remark	Pol/Phase	Note
MHz	dBuV/m	dBuV	dB/m	dBuV/m	dB	cm	deg		
1	2387.64	42.76	5.66	37.18	54.00	-11.24	314	170 Average	Vertical
2 *	2481.92	91.54	54.42	37.12	54.00	37.54	314	170 Average	Vertical
3	2884.54	43.03	5.14	37.89	54.00	-10.97	314	170 Average	Vertical

BLE\_1M

Middle Channel (Horizontal) Peak

Middle Channel (Vertical) Peak



TUV Rheinland Taiwan Ltd.  
No. 458-18, Sec 2, Fenliao, Linkou Dist., New Taipei City 244, Taiwan(R.O.C.)  
Tel: +886-2172-1000 Fax: +886-2172-1322

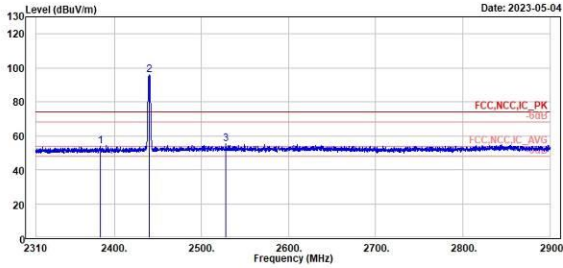

Freq	Level	Read	Level	Factor	Limit	Over	APos	TPos	Remark	Pol/Phase	Note
MHz	dBuV/m	dBuV	dB/m	dBuV/m	dB	cm	deg				
1	2384.46	53.78	16.69	37.09	74.00	-20.22	132	181	Peak	Horizontal	
2 *	2449.00	95.95	58.57	37.38	74.00	21.95	132	181	Peak	Horizontal	
3	2527.47	55.13	17.65	37.48	74.00	-18.87	132	181	Peak	Horizontal	



TUV Rheinland Taiwan Ltd.  
No. 458-18, Sec 2, Fenliao, Linkou Dist., New Taipei City 244, Taiwan(R.O.C.)  
Tel: +886-2172-1000 Fax: +886-2172-1322

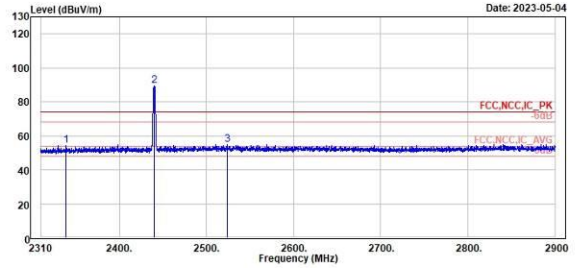

Freq	Level	Read	Level	Factor	Limit	Over	APos	TPos	Remark	Pol/Phase	Note
MHz	dBuV/m	dBuV	dB/m	dBuV/m	dB	cm	deg				
1	2338.44	54.36	17.38	36.98	74.00	-19.64	397	178	Peak	Vertical	
2 *	2449.00	89.46	52.08	37.38	74.00	15.46	397	178	Peak	Vertical	
3	2523.58	55.01	17.54	37.47	74.00	-18.99	397	178	Peak	Vertical	

BLE\_1M

Middle Channel (Horizontal) Average

Middle Channel (Vertical) Average



TUV Rheinland Taiwan Ltd.  
No. 458-18, Sec 2, Fenliao, Linkou Dist., New Taipei City 244, Taiwan(R.O.C.)  
Tel: +886-2172-1000 Fax: +886-2172-1322

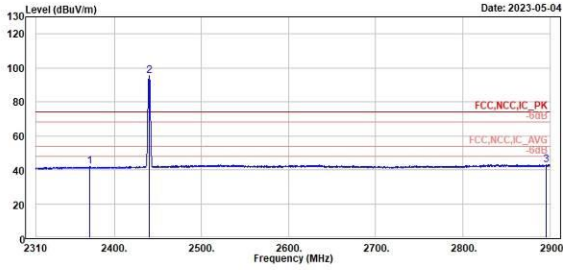

Freq	Level	Read Level	Factor	Limit Line	Over Limit	APos	TPos	Remark	Pol/Phase	Note
MHz	dBuV/m	dBuV	dB/m	dBuV/m	dB	cm	deg			
1	2371.83	41.82	4.74	37.08	54.00	-12.18	132	181 Average	Horizontal	
2 *	2440.00	95.90	58.12	37.38	54.00	41.50	132	181 Average	Horizontal	
3	2895.40	43.06	5.12	37.94	54.00	-10.94	132	181 Average	Horizontal	



TUV Rheinland Taiwan Ltd.  
No. 458-18, Sec 2, Fenliao, Linkou Dist., New Taipei City 244, Taiwan(R.O.C.)  
Tel: +886-2172-1000 Fax: +886-2172-1322

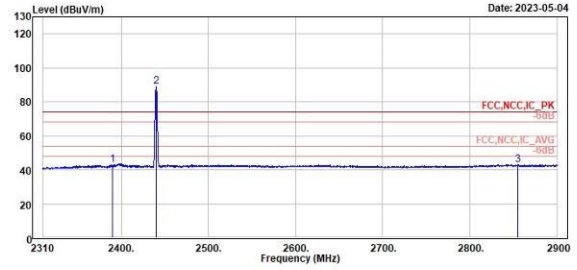

Freq	Level	Read Level	Factor	Limit Line	Over Limit	APos	TPos	Remark	Pol/Phase	Note
MHz	dBuV/m	dBuV	dB/m	dBuV/m	dB	cm	deg			
1	2390.00	42.99	5.89	37.10	54.00	-11.01	397	178 Average	Vertical	
2 *	2440.00	88.93	51.55	37.38	54.00	34.53	397	178 Average	Vertical	
3	2855.28	43.18	5.43	37.75	54.00	-10.82	397	178 Average	Vertical	



BLE\_1M

High Channel (Horizontal) Peak

High Channel (Vertical) Peak



TUV Rheinland Taiwan Ltd.  
No. 458-18, Sec 2, Fenliao, Linkou Dist., New Taipei City 244, Taiwan(R.O.C.)  
Tel: +886-2172-1000 Fax: +886-2172-1322

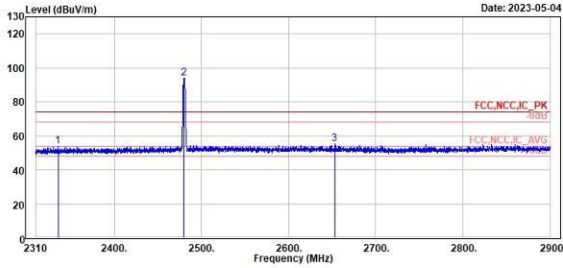

Peak	Freq (MHz)	Level (dBuV/m)	Read Level (dBuV)	Level Factor (dB/m)	Limit Line (dBuV/m)	Over Limit (dB)	APos (cm)	TPos (deg)	Remark	Pol/Phase	Note
1	2335.37	54.06	17.10	36.96	74.00	-19.94	100	290	Peak	Horizontal	
2 *	2489.00	93.88	56.40	37.48	74.00	19.88	100	290	Peak	Horizontal	
3	2652.79	55.23	18.00	37.23	74.00	-18.77	100	290	Peak	Horizontal	



TUV Rheinland Taiwan Ltd.  
No. 458-18, Sec 2, Fenliao, Linkou Dist., New Taipei City 244, Taiwan(R.O.C.)  
Tel: +886-2172-1000 Fax: +886-2172-1322

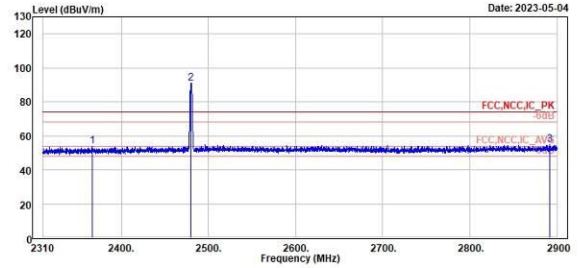

Peak	Freq (MHz)	Level (dBuV/m)	Read Level (dBuV)	Level Factor (dB/m)	Limit Line (dBuV/m)	Over Limit (dB)	APos (cm)	TPos (deg)	Remark	Pol/Phase	Note
1	2366.88	53.65	16.57	37.08	74.00	-20.35	137	87	Peak	Vertical	
2 *	2489.00	90.90	53.42	37.48	74.00	16.90	137	87	Peak	Vertical	
3	2891.86	54.69	16.76	37.93	74.00	-19.31	137	87	Peak	Vertical	

BLE\_1M

High Channel (Horizontal) Average

High Channel (Vertical) Average



TUV Rheinland Taiwan Ltd.  
No. 458-18, Sec 2, Fenliao, Linkou Dist., New Taipei City 244, Taiwan(R.O.C.)  
Tel: +886-2172-1000 Fax: +886-2172-1322

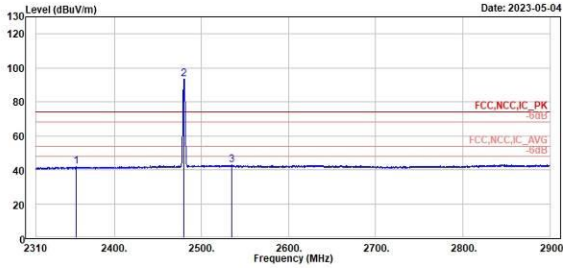

Freq	Level	Read	Level	Limit	Over	APos	TPos	Remark	Pol/Phase	Note
MHz	dBuV/m	dBuV	dB/m	dBuV/m	dB	cm	deg			
1	2355.78	41.82	4.75	37.07	54.00	-12.18	100	290 Average	Horizontal	
2 *	2489.00	93.51	56.83	37.48	54.00	39.51	100	290 Average	Horizontal	
3	2534.32	42.92	5.46	37.46	54.00	-11.08	100	290 Average	Horizontal	



TUV Rheinland Taiwan Ltd.  
No. 458-18, Sec 2, Fenliao, Linkou Dist., New Taipei City 244, Taiwan(R.O.C.)  
Tel: +886-2172-1000 Fax: +886-2172-1322

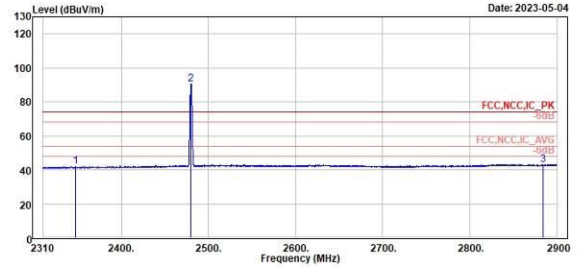

Freq	Level	Read	Level	Limit	Over	APos	TPos	Remark	Pol/Phase	Note
MHz	dBuV/m	dBuV	dB/m	dBuV/m	dB	cm	deg			
1	2347.64	41.94	4.89	37.05	54.00	-12.06	137	87 Average	Vertical	
2 *	2489.00	98.46	52.98	37.48	54.00	36.46	137	87 Average	Vertical	
3	2883.83	43.15	5.26	37.89	54.00	-10.85	137	87 Average	Vertical	

BLE\_2M

Low Channel (Horizontal) Peak

Low Channel (Vertical) Peak



TUV Rheinland Taiwan Ltd.  
No. 458-18, Sec 2, Fenliao, Linkou Dist., New Taipei City 244, Taiwan(R.O.C.)  
Tel: +886-2172-1000 Fax: +886-2172-1322

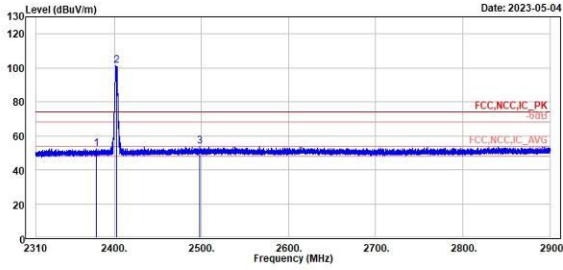

Freq	Level	Read	Level	Factor	Limit	Over	APos	TPos	Remark	Pol/Phase	Note
MHz	dBuV/m	dBuV	dB/m	dBuV/m	dB	cm	deg				
1	2378.86	52.61	15.52	37.09	74.00	-21.39	274	202	Peak	Horizontal	
2 *	2402.80	101.16	64.84	37.12	74.00	27.16	274	202	Peak	Horizontal	
3	2497.55	53.93	16.43	37.50	74.00	-20.07	274	202	Peak	Horizontal	



TUV Rheinland Taiwan Ltd.  
No. 458-18, Sec 2, Fenliao, Linkou Dist., New Taipei City 244, Taiwan(R.O.C.)  
Tel: +886-2172-1000 Fax: +886-2172-1322

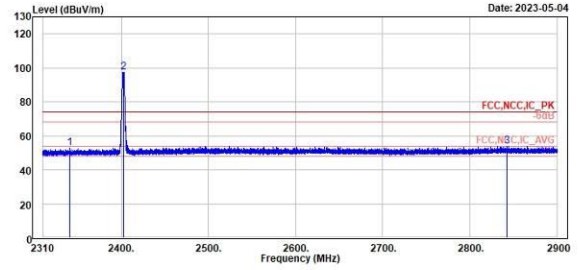

Freq	Level	Read	Level	Factor	Limit	Over	APos	TPos	Remark	Pol/Phase	Note
MHz	dBuV/m	dBuV	dB/m	dBuV/m	dB	cm	deg				
1	2340.44	52.95	15.96	36.99	74.00	-21.05	328	202	Peak	Vertical	
2 *	2402.80	97.28	68.16	37.12	74.00	23.28	328	202	Peak	Vertical	
3	2841.94	53.87	16.22	37.65	74.00	-20.13	328	202	Peak	Vertical	

BLE\_2M

Low Channel (Horizontal) Average

Low Channel (Vertical) Average



TUV Rheinland Taiwan Ltd.  
No. 458-18, Sec 2, Fenliao, Linkou Dist., New Taipei City 244, Taiwan(R.O.C.)  
Tel: +886-2172-1000 Fax: +886-2172-1322

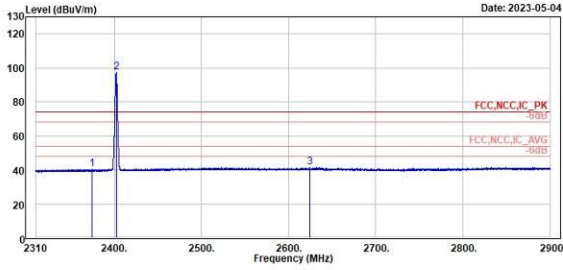

Freq	Level	Read	Limit	Over	APos	TPos	Remark	Pol/Phase	Note
MHz	dBuV/m	dBuV	dB/m	dBuV/m	dB	cm	deg		
1	2374.07	40.33	3.25	37.08	54.00	-13.67	274	202 Average	Horizontal
2 *	2402.00	97.15	60.03	37.12	54.00	43.15	274	202 Average	Horizontal
3	2624.30	41.53	4.17	37.36	54.00	-12.47	274	202 Average	Horizontal



TUV Rheinland Taiwan Ltd.  
No. 458-18, Sec 2, Fenliao, Linkou Dist., New Taipei City 244, Taiwan(R.O.C.)  
Tel: +886-2172-1000 Fax: +886-2172-1322

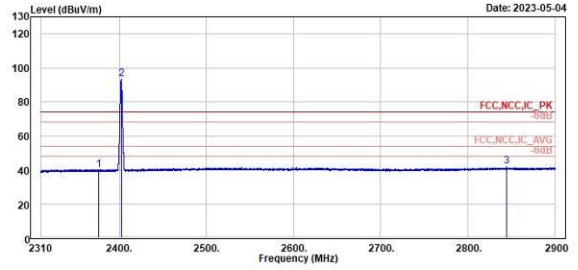

Freq	Level	Read	Limit	Over	APos	TPos	Remark	Pol/Phase	Note
MHz	dBuV/m	dBuV	dB/m	dBuV/m	dB	cm	deg		
1	2376.05	40.22	3.13	37.09	54.00	-13.70	328	202 Average	Vertical
2 *	2402.00	93.34	56.22	37.12	54.00	39.34	328	202 Average	Vertical
3	2844.19	41.89	4.22	37.67	54.00	-12.11	328	202 Average	Vertical

BLE\_2M

Middle Channel (Horizontal) Peak

Middle Channel (Vertical) Peak



TUV Rheinland Taiwan Ltd.  
No. 458-18, Sec 2, Fenliao, Linkou Dist., New Taipei City 244, Taiwan(R.O.C.)  
Tel: +886-2172-1000 Fax: +886-2172-1322

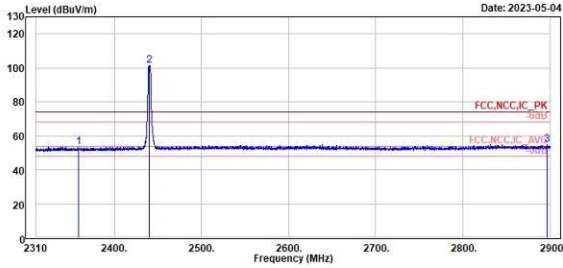

Freq	Level	Read	Level	Factor	Limit	Over	APos	TPos	Remark	Pol/Phase	Note
MHz	dBuV/m	dBuV	dB/m	dBuV/m	dB	cm	deg				
1	2358.85	53.47	16.48	37.07	74.00	-20.53	300		201 Peak	Horizontal	
2 *	2440.00	101.56	64.18	37.38	74.00	27.56	300		201 Peak	Horizontal	
3	2896.34	54.85	16.90	37.95	74.00	-19.15	300		201 Peak	Horizontal	



TUV Rheinland Taiwan Ltd.  
No. 458-18, Sec 2, Fenliao, Linkou Dist., New Taipei City 244, Taiwan(R.O.C.)  
Tel: +886-2172-1000 Fax: +886-2172-1322

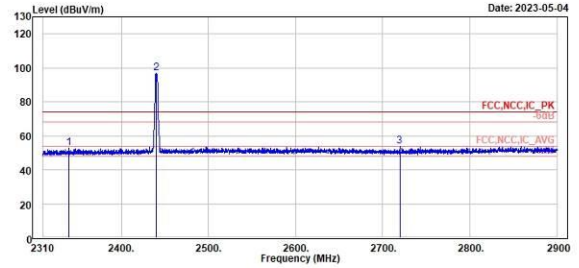

Freq	Level	Read	Level	Factor	Limit	Over	APos	TPos	Remark	Pol/Phase	Note
MHz	dBuV/m	dBuV	dB/m	dBuV/m	dB	cm	deg				
1	2339.62	52.81	15.82	36.99	74.00	-21.19	327		204 Peak	Vertical	
2 *	2440.00	96.76	59.38	37.38	74.00	22.76	327		204 Peak	Vertical	
3	2719.34	53.85	16.57	37.28	74.00	-20.15	327		204 Peak	Vertical	

BLE\_2M

Middle Channel (Horizontal) Average

Middle Channel (Vertical) Average



TUV Rheinland Taiwan Ltd.  
No. 458-18, Sec 2, Fenliao, Linkou Dist., New Taipei City 244, Taiwan(R.O.C.)  
Tel: +886-2172-1000 Fax: +886-2172-1322

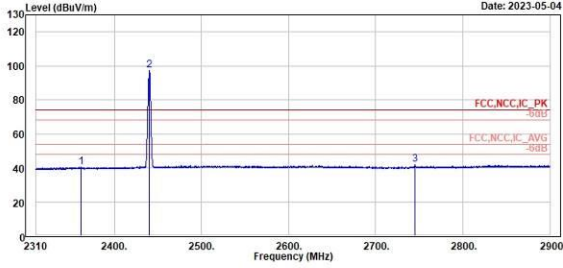

Freq	Level	Read	Limit	Over	APos	TPos	Remark	Pol/Phase	Note
MHz	dBuV/m	dBuV	dB/m	dBuV/m	dB	cm	deg		
1	2361.68	40.45	3.38	37.07	54.00	-13.55	300	201 Average	Horizontal
2 *	2440.00	97.59	60.21	37.38	54.00	43.59	300	201 Average	Horizontal
3	2744.71	41.90	4.49	37.41	54.00	-12.10	300	201 Average	Horizontal



TUV Rheinland Taiwan Ltd.  
No. 458-18, Sec 2, Fenliao, Linkou Dist., New Taipei City 244, Taiwan(R.O.C.)  
Tel: +886-2172-1000 Fax: +886-2172-1322

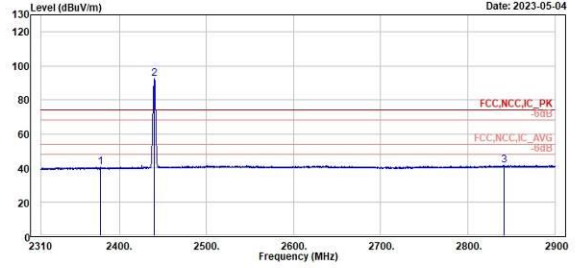

Freq	Level	Read	Limit	Over	APos	TPos	Remark	Pol/Phase	Note
MHz	dBuV/m	dBuV	dB/m	dBuV/m	dB	cm	deg		
1	2377.97	40.38	3.29	37.09	54.00	-13.62	327	204 Average	Vertical
2 *	2440.00	92.68	55.30	37.38	54.00	38.68	327	204 Average	Vertical
3	2841.83	41.76	4.12	37.64	54.00	-12.24	327	204 Average	Vertical

BLE\_2M

High Channel (Horizontal) Peak

High Channel (Vertical) Peak



TUV Rheinland Taiwan Ltd.  
No. 458-18, Sec 2, Fenliao, Linkou Dist., New Taipei City 244, Taiwan(R.O.C.)  
Tel: +886-2172-1000 Fax: +886-2172-1322

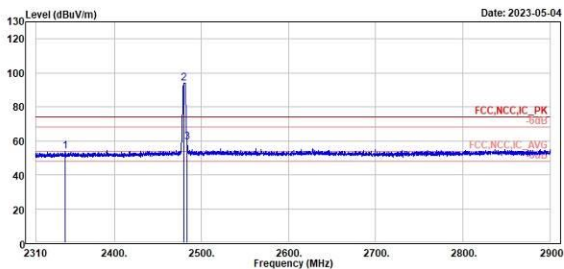

Freq	Level	Read	Level	Limit	Over	APos	TPos	Remark	Pol/Phase	Note
MHz	dBuV/m	dBuV	dB/m	dBuV/m	dB	cm	deg			
1	2343.63	54.02	17.00	37.02	74.00	-19.98	128	209 Peak	Horizontal	
2 *	2489.00	94.07	56.59	37.48	74.00	20.07	128	209 Peak	Horizontal	
3	2483.58	59.40	21.92	37.48	74.00	-14.60	128	209 Peak	Horizontal	



TUV Rheinland Taiwan Ltd.  
No. 458-18, Sec 2, Fenliao, Linkou Dist., New Taipei City 244, Taiwan(R.O.C.)  
Tel: +886-2172-1000 Fax: +886-2172-1322

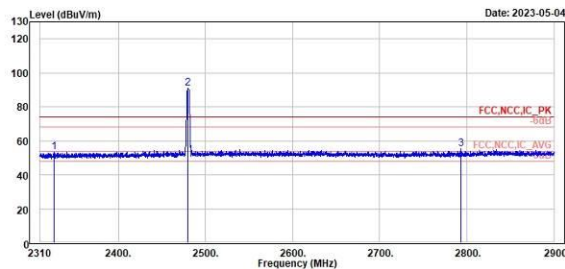

Freq	Level	Read	Level	Limit	Over	APos	TPos	Remark	Pol/Phase	Note
MHz	dBuV/m	dBuV	dB/m	dBuV/m	dB	cm	deg			
1	2326.17	53.35	16.45	36.90	74.00	-20.65	262	206 Peak	Vertical	
2 *	2489.00	98.77	53.29	37.48	74.00	16.77	262	206 Peak	Vertical	
3	2793.45	55.33	18.03	37.30	74.00	-18.67	262	206 Peak	Vertical	

BLE\_2M

High Channel (Horizontal) Average

High Channel (Vertical) Average



TUV Rheinland Taiwan Ltd.  
No. 458-18, Sec 2, Fenliao, Linkou Dist., New Taipei City 244, Taiwan(R.O.C.)  
Tel: +886-2172-1000 Fax: +886-2172-1322

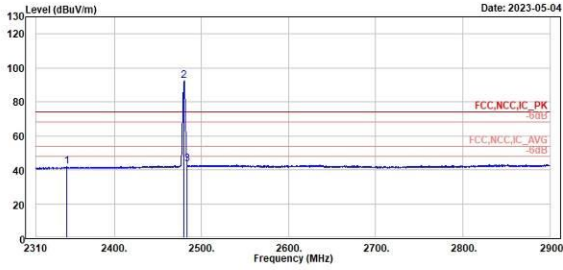

Freq	Level	Read Level	Factor	Limit Line	Over Limit	APos	TPos	Remark	Pol/Phase	Note
MHz	dBuV/m	dBuV	dB/m	dBuV/m	dB	cm	deg			
1	2345.48	41.78	4.75	37.03	54.00	-12.22	128	289 Average	Horizontal	
2 *	2489.00	92.21	54.73	37.48	54.00	38.21	128	289 Average	Horizontal	
3	2483.46	43.35	5.87	37.48	54.00	-10.65	128	289 Average	Horizontal	



TUV Rheinland Taiwan Ltd.  
No. 458-18, Sec 2, Fenliao, Linkou Dist., New Taipei City 244, Taiwan(R.O.C.)  
Tel: +886-2172-1000 Fax: +886-2172-1322

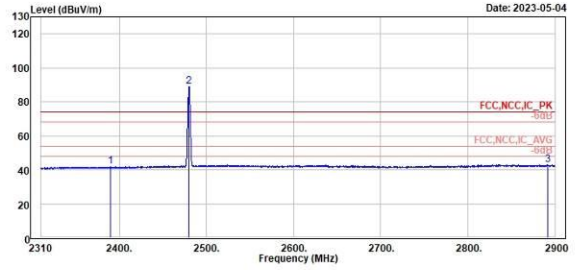

Freq	Level	Read Level	Factor	Limit Line	Over Limit	APos	TPos	Remark	Pol/Phase	Note
MHz	dBuV/m	dBuV	dB/m	dBuV/m	dB	cm	deg			
1	2389.77	41.84	4.74	37.10	54.00	-12.16	262	206 Average	Vertical	
2 *	2489.00	88.89	51.41	37.48	54.00	34.89	262	206 Average	Vertical	
3	2891.62	43.18	5.25	37.93	54.00	-10.82	262	206 Average	Vertical	



Spurious Emissions, Tx Mode, 9kHz ~ 30MHz

BLE\_2M

High Channel (Open) 9kHz~150kHz

High Channel (Open) 150kHz~30MHz



TÜV Rheinland Taiwan Ltd.  
No. 458-18, Sec 2, Fenhiao, Linkou Dist., New Taipei City 244, Taiwan(R.O.C.)  
Tel: +886-2172-1000 Fax: +886-2172-1322

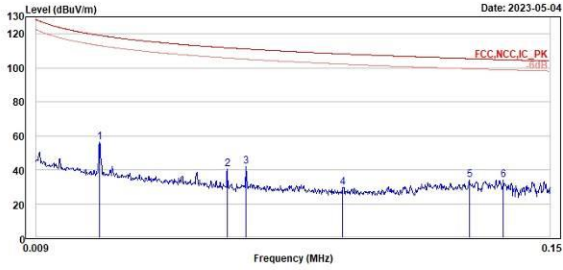

Peak	Freq	Level	Read	Limit	Over	APos	TPos	Remark	PoI/Phase	Note
	MHz	dBuV/m	dBuV	dB/m	dBuV/m	dB	cm	deg		
1	0.03	56.19	37.24	18.95	119.13	-62.94	100	208 Peak	Open	
2	0.06	40.44	21.59	18.85	111.82	-71.38	100	232 Peak	Open	
3	0.07	42.05	23.33	18.72	111.12	-69.07	100	166 Peak	Open	
4	0.09	29.00	11.51	18.09	108.22	-78.62	100	150 Peak	Open	
5	0.13	34.02	15.98	18.04	105.46	-71.44	100	76 Peak	Open	
6	0.14	34.14	16.06	18.00	104.85	-70.71	100	80 Peak	Open	



TÜV Rheinland Taiwan Ltd.  
No. 458-18, Sec 2, Fenhiao, Linkou Dist., New Taipei City 244, Taiwan(R.O.C.)  
Tel: +886-2172-1000 Fax: +886-2172-1322

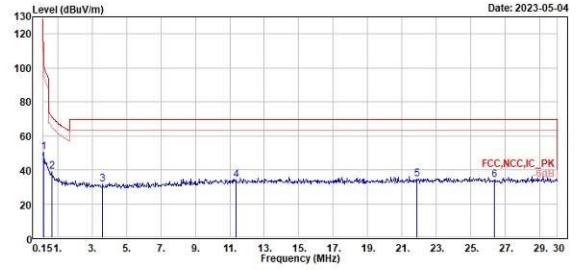

Peak	Freq	Level	Read	Limit	Over	APos	TPos	Remark	PoI/Phase	Note
	MHz	dBuV/m	dBuV	dB/m	dBuV/m	dB	cm	deg		
1	0.18	50.43	32.18	18.25	102.50	-52.07	100	67 Peak	Open	
2	0.66	39.02	20.10	18.92	71.25	-32.23	100	84 Peak	Open	
3	3.61	31.58	11.99	19.59	69.50	-37.92	100	130 Peak	Open	
4	11.34	34.10	12.45	21.65	69.50	-35.40	100	167 Peak	Open	
5	21.85	34.77	12.51	22.26	69.50	-34.73	100	89 Peak	Open	
6	26.36	34.14	11.84	22.30	69.50	-35.36	100	72 Peak	Open	

**Spurious Emissions, Tx Mode, 30MHz ~ 1GHz**
**BLE\_2M**
**High Channel (Horizontal)**
**High Channel (Vertical)**

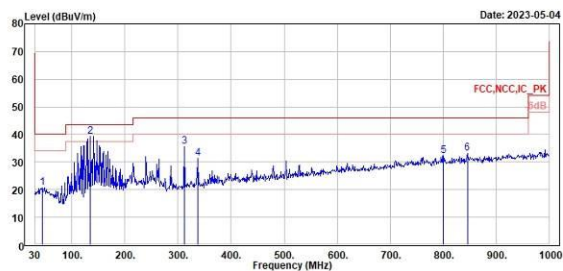

TÜV Rheinland Taiwan Ltd.  
 No. 458-18, Sec 2, Fenliao, Linkou Dist., New Taipei City 244, Taiwan(R.O.C.)  
 Tel: +886-2172-1000 Fax: +886-2172-1322



Peak	Freq	Level	Read	Limit	Over	APos	TPos	Remark	Pol/Phase	Note
	MHz	dBuV/m	dBuV	dB/m	dBuV/m	dB	cm	deg		
1	44.55	30.81	28.10	-7.29	40.00	-19.19	300	57 Peak	Horizontal	
2	134.76	39.22	47.27	-8.05	43.50	-4.28	200	171 Peak	Horizontal	
3	312.27	35.70	42.22	-6.52	46.00	-10.30	100	152 Peak	Horizontal	
4	337.49	31.29	36.99	-5.70	46.00	-14.71	100	145 Peak	Horizontal	
5	801.15	32.39	29.58	2.81	46.00	-13.61	109	360 Peak	Horizontal	
6	845.77	33.22	29.00	3.42	46.00	-12.78	282	11 Peak	Horizontal	

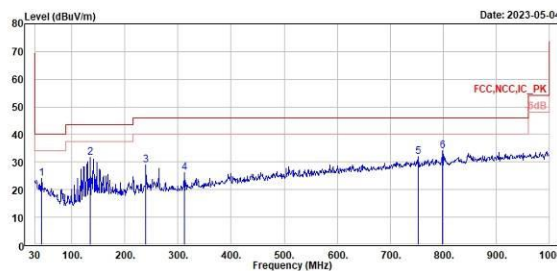

TÜV Rheinland Taiwan Ltd.  
 No. 458-18, Sec 2, Fenliao, Linkou Dist., New Taipei City 244, Taiwan(R.O.C.)  
 Tel: +886-2172-1000 Fax: +886-2172-1322



Peak	Freq	Level	Read	Limit	Over	APos	TPos	Remark	Pol/Phase	Note
	MHz	dBuV/m	dBuV	dB/m	dBuV/m	dB	cm	deg		
1	42.61	24.15	31.55	-7.40	40.00	-15.85	100	74 Peak	Vertical	
2	134.76	31.50	39.55	-8.05	43.50	-12.00	100	84 Peak	Vertical	
3	239.52	28.79	37.10	-8.31	46.00	-17.21	200	128 Peak	Vertical	
4	312.27	26.07	32.59	-6.52	46.00	-19.93	100	88 Peak	Vertical	
5	753.62	32.05	29.78	2.27	46.00	-13.95	200	275 Peak	Vertical	
6	799.21	33.93	31.08	2.85	46.00	-12.07	100	146 Peak	Vertical	

Spurious Emissions, Tx Mode, 1GHz ~ 26.5GHz

BLE\_1M

Low Channel (Horizontal)

Low Channel (Vertical)



TUV Rheinland Taiwan Ltd.  
No. 458-18, Sec 2, Fenliao, Linkou Dist., New Taipei City 244, Taiwan(R.O.C.)  
Tel: +886-2172-1000 Fax: +886-2172-1322

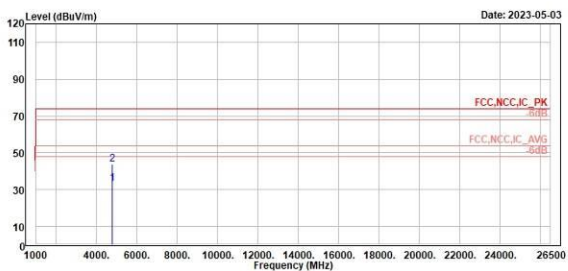

Line	Freq	Level	Read Level	Factor	Limit Line	Over Limit	APos	TPos	Remark	PoI/Phase	Note
	MHz	dBuV/m	dBuV	dB/m	dBuV/m	dB	cm	deg			
1	4884.00	33.21	43.61	-10.40	54.00	-20.79	100	82	Average	Horizontal	
2	4884.00	43.87	54.27	-10.40	74.00	-30.13	100	82	Peak	Horizontal	



TUV Rheinland Taiwan Ltd.  
No. 458-18, Sec 2, Fenliao, Linkou Dist., New Taipei City 244, Taiwan(R.O.C.)  
Tel: +886-2172-1000 Fax: +886-2172-1322

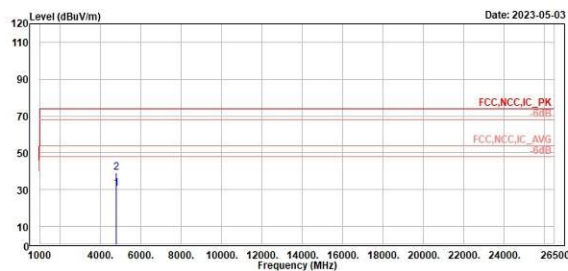

Line	Freq	Level	Read Level	Factor	Limit Line	Over Limit	APos	TPos	Remark	PoI/Phase	Note
	MHz	dBuV/m	dBuV	dB/m	dBuV/m	dB	cm	deg			
1	4884.00	39.54	49.94	-10.40	54.00	-23.46	400	221	Average	Vertical	
2	4884.00	39.32	49.72	-10.40	74.00	-34.68	400	221	Peak	Vertical	

BLE\_1M

Middle Channel (Horizontal)

Middle Channel (Vertical)



TUV Rheinland Taiwan Ltd.  
No. 458-18, Sec 2, Fenliao, Linkou Dist., New Taipei City 244, Taiwan(R.O.C.)  
Tel: +886-2172-1000 Fax: +886-2172-1322

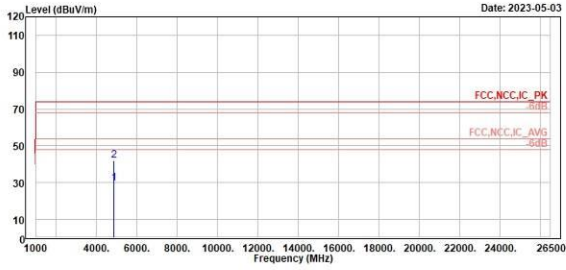

Freq	Level	Read Level	Factor	Limit Line	Over Limit	APos	TPos	Remark	Pol/Phase	Note
MHz	dBuV/m	dBuV	dB/m	dBuV/m	dB	cm	deg			
1	4889.00	29.62	39.95	-10.33	54.00	-24.38	100	94 Average	Horizontal	
2	4889.00	41.82	52.15	-10.33	74.00	-32.18	100	94 Peak	Horizontal	



TUV Rheinland Taiwan Ltd.  
No. 458-18, Sec 2, Fenliao, Linkou Dist., New Taipei City 244, Taiwan(R.O.C.)  
Tel: +886-2172-1000 Fax: +886-2172-1322

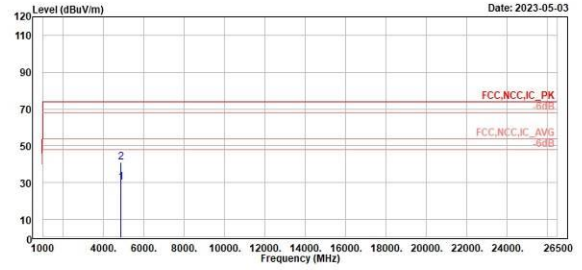

Freq	Level	Read Level	Factor	Limit Line	Over Limit	APos	TPos	Remark	Pol/Phase	Note
MHz	dBuV/m	dBuV	dB/m	dBuV/m	dB	cm	deg			
1	4889.00	30.18	40.51	-10.33	54.00	-23.82	171	360 Average	Vertical	
2	4889.00	41.22	51.55	-10.33	74.00	-32.78	171	360 Peak	Vertical	

BLE\_1M

High Channel (Horizontal)

High Channel (Vertical)



TUV Rheinland Taiwan Ltd.  
No. 458-18, Sec 2, Fenliao, Linkou Dist., New Taipei City 244, Taiwan(R.O.C.)  
Tel: +886-2172-1000 Fax: +886-2172-1322

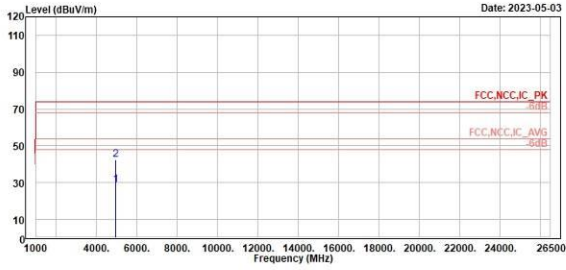

Line	Freq	Level	Read Level	Factor	Limit Line	Over Limit	APos	TPos	Remark	PoI/Phase	Note
	MHz	dBuV/m	dBuV	dB/m	dBuV/m	dB	cm	deg			
1	4969.00	28.65	38.87	-10.22	54.00	-25.35	200	92	Average	Horizontal	
2	4969.00	42.43	52.65	-10.22	74.00	-31.57	200	92	Peak	Horizontal	



TUV Rheinland Taiwan Ltd.  
No. 458-18, Sec 2, Fenliao, Linkou Dist., New Taipei City 244, Taiwan(R.O.C.)  
Tel: +886-2172-1000 Fax: +886-2172-1322

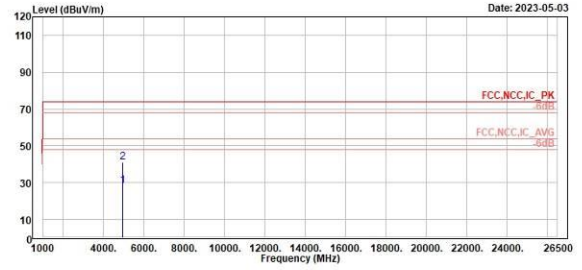

Line	Freq	Level	Read Level	Factor	Limit Line	Over Limit	APos	TPos	Remark	PoI/Phase	Note
	MHz	dBuV/m	dBuV	dB/m	dBuV/m	dB	cm	deg			
1	4969.00	28.37	38.59	-10.22	54.00	-25.63	100	11	Average	Vertical	
2	4969.00	41.21	51.43	-10.22	74.00	-32.79	100	11	Peak	Vertical	

BLE\_2M

Low Channel (Horizontal)

Low Channel (Vertical)



TUV Rheinland Taiwan Ltd.  
No. 458-18, Sec 2, Fenliao, Linkou Dist., New Taipei City 244, Taiwan(R.O.C.)  
Tel: +886-2172-1000 Fax: +886-2172-1322

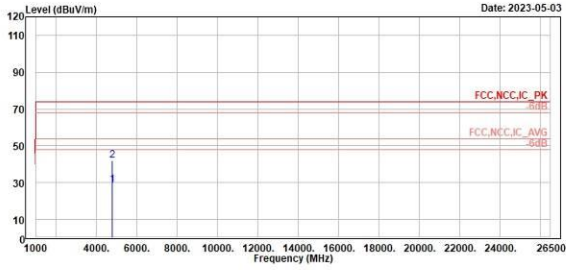

Freq	Level	Read Level	Factor	Limit Line	Over Limit	APos	TPos	Remark	Pol/Phase	Note
MHz	dBuV/m	dBuV	dB/m	dBuV/m	dB	cm	deg			
1	4884.00	28.77	39.17	-10.40	54.00	-25.23	100	49 Average	Horizontal	
2	4884.00	41.97	52.37	-10.40	74.00	-32.03	100	49 Peak	Horizontal	



TUV Rheinland Taiwan Ltd.  
No. 458-18, Sec 2, Fenliao, Linkou Dist., New Taipei City 244, Taiwan(R.O.C.)  
Tel: +886-2172-1000 Fax: +886-2172-1322

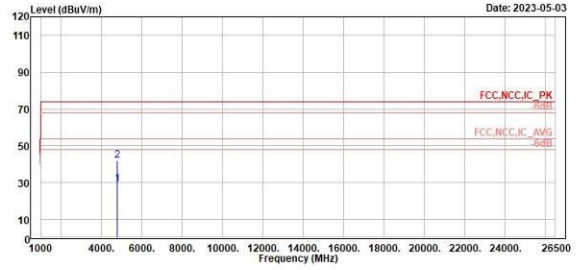

Freq	Level	Read Level	Factor	Limit Line	Over Limit	APos	TPos	Remark	Pol/Phase	Note
MHz	dBuV/m	dBuV	dB/m	dBuV/m	dB	cm	deg			
1	4884.00	29.29	39.69	-10.40	54.00	-24.71	400	347 Average	Vertical	
2	4884.00	41.89	52.29	-10.40	74.00	-32.11	400	347 Peak	Vertical	

BLE\_2M

Middle Channel (Horizontal)

Middle Channel (Vertical)



TUV Rheinland Taiwan Ltd.  
No. 458-18, Sec 2, Fenhiao, Linkou Dist., New Taipei City 244, Taiwan(R.O.C.)  
Tel: +886-2172-1000 Fax: +886-2172-1322

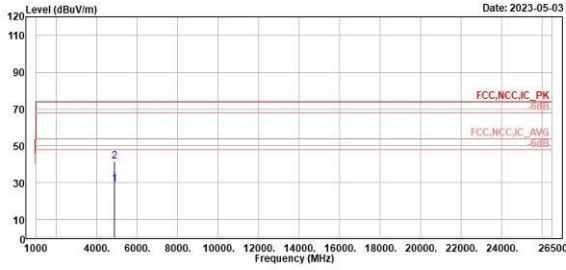

Line	Freq	Level	Read Level	Factor	Limit Line	Over Limit	APos	TPos	Remark	Pol/Phase	Note
	MHz	dBuV/m	dBuV	dB/m	dBuV/m	dB	cm	deg			
1	4889.00	29.26	39.59	-10.33	54.00	-24.74	490	202	Average	Horizontal	
2	4889.00	41.50	51.83	-10.33	74.00	-32.50	490	202	Peak	Horizontal	



TUV Rheinland Taiwan Ltd.  
No. 458-18, Sec 2, Fenhiao, Linkou Dist., New Taipei City 244, Taiwan(R.O.C.)  
Tel: +886-2172-1000 Fax: +886-2172-1322

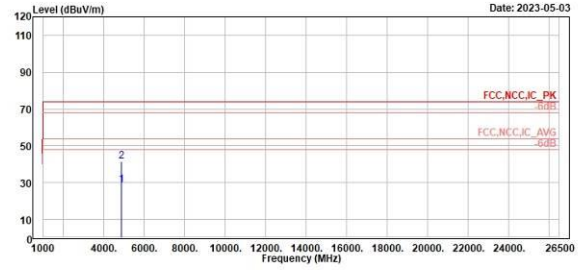

Line	Freq	Level	Read Level	Factor	Limit Line	Over Limit	APos	TPos	Remark	Pol/Phase	Note
	MHz	dBuV/m	dBuV	dB/m	dBuV/m	dB	cm	deg			
1	4889.00	28.59	38.92	-10.33	54.00	-25.41	290	141	Average	Vertical	
2	4889.00	41.38	51.71	-10.33	74.00	-32.62	290	141	Peak	Vertical	

BLE\_2M

High Channel (Horizontal)

High Channel (Vertical)



TUV Rheinland Taiwan Ltd.  
No. 458-18, Sec 2, Fenhiao, Linkou Dist., New Taipei City 244, Taiwan(R.O.C.)  
Tel: +886-2172-1000 Fax: +886-2172-1322

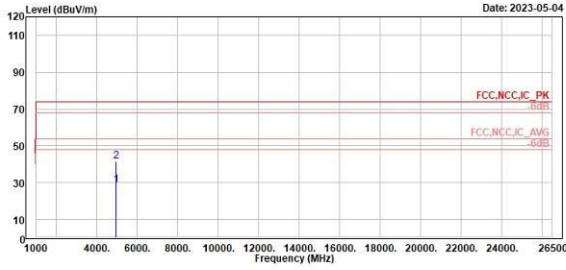

Freq	Level	Read Level	Factor	Limit Line	Over Limit	APos	TPos	Remark	Pol/Phase	Note
MHz	dBuV/m	dBuV	dB/m	dBuV/m	dB	cm	deg			
1	4969.00	28.57	38.79	-10.22	54.00	-25.43	100	330 Average	Horizontal	
2	4969.00	41.47	51.69	-10.22	74.00	-32.53	100	330 Peak	Horizontal	



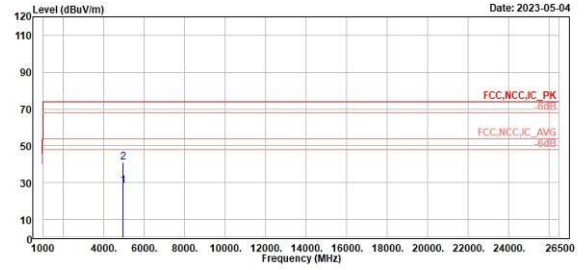

TUV Rheinland Taiwan Ltd.  
No. 458-18, Sec 2, Fenhiao, Linkou Dist., New Taipei City 244, Taiwan(R.O.C.)  
Tel: +886-2172-1000 Fax: +886-2172-1322



Freq	Level	Read Level	Factor	Limit Line	Over Limit	APos	TPos	Remark	Pol/Phase	Note
MHz	dBuV/m	dBuV	dB/m	dBuV/m	dB	cm	deg			
1	4969.00	28.35	38.57	-10.22	54.00	-25.65	173	360 Average	Vertical	
2	4969.00	41.12	51.34	-10.22	74.00	-32.68	173	360 Peak	Vertical	

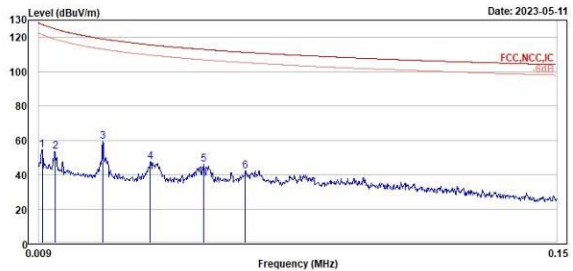

<EUT with Charger Box>  
Spurious Emissions, Tx Mode, 9kHz ~ 30MHz

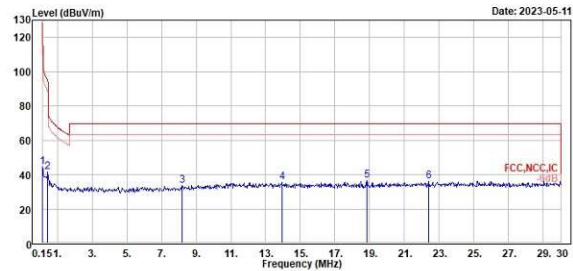
EUT with all RF functions																																																																																																																																																																	
(Open) 9kHz~150kHz	(Open) 150kHz~30MHz																																																																																																																																																																
<div style="display: flex; justify-content: space-between; align-items: center;">  <div style="font-size: 8px;">                     TÜV Rheinland Taiwan Ltd.                      No. 458-18, Sec 2, Fenliao, Linkou Dist., New Taipei City 244, Taiwan(R.O.C.)                      Tel: +886-2172-1000 Fax: +886-2172-1322                 </div> </div> <div style="text-align: right; font-size: 10px; margin-top: 10px;">Date: 2023-05-11</div>  <table border="1" style="width:100%; border-collapse: collapse; font-size: 8px; margin-top: 10px;"> <thead> <tr> <th>Freq</th> <th>Level</th> <th>Read</th> <th>Limit</th> <th>Over</th> <th>APos</th> <th>TPos</th> <th>Remark</th> <th>Pol/Phase</th> <th>Note</th> </tr> <tr> <th>MHz</th> <th>dBuV/m</th> <th>dBuV</th> <th>dB/m</th> <th>dBuV/m</th> <th>dB</th> <th>cm</th> <th>deg</th> <th></th> <th></th> </tr> </thead> <tbody> <tr><td>1</td><td>0.01</td><td>54.52</td><td>36.00</td><td>17.72</td><td>127.60</td><td>-73.08</td><td>100</td><td>360 Peak</td><td>Open</td></tr> <tr><td>2</td><td>0.01</td><td>53.61</td><td>35.64</td><td>17.97</td><td>124.97</td><td>-71.36</td><td>100</td><td>197 Peak</td><td>Open</td></tr> <tr><td>3</td><td>0.03</td><td>59.40</td><td>40.45</td><td>18.95</td><td>119.13</td><td>-59.73</td><td>100</td><td>177 Peak</td><td>Open</td></tr> <tr><td>4</td><td>0.04</td><td>47.36</td><td>28.20</td><td>19.16</td><td>115.67</td><td>-68.31</td><td>100</td><td>176 Peak</td><td>Open</td></tr> <tr><td>5</td><td>0.05</td><td>45.95</td><td>26.93</td><td>19.02</td><td>112.95</td><td>-67.00</td><td>100</td><td>73 Peak</td><td>Open</td></tr> <tr><td>6</td><td>0.07</td><td>42.84</td><td>23.29</td><td>18.75</td><td>111.30</td><td>-69.26</td><td>100</td><td>192 Peak</td><td>Open</td></tr> </tbody> </table>	Freq	Level	Read	Limit	Over	APos	TPos	Remark	Pol/Phase	Note	MHz	dBuV/m	dBuV	dB/m	dBuV/m	dB	cm	deg			1	0.01	54.52	36.00	17.72	127.60	-73.08	100	360 Peak	Open	2	0.01	53.61	35.64	17.97	124.97	-71.36	100	197 Peak	Open	3	0.03	59.40	40.45	18.95	119.13	-59.73	100	177 Peak	Open	4	0.04	47.36	28.20	19.16	115.67	-68.31	100	176 Peak	Open	5	0.05	45.95	26.93	19.02	112.95	-67.00	100	73 Peak	Open	6	0.07	42.84	23.29	18.75	111.30	-69.26	100	192 Peak	Open	<div style="display: flex; justify-content: space-between; align-items: center;">  <div style="font-size: 8px;">                     TÜV Rheinland Taiwan Ltd.                      No. 458-18, Sec 2, Fenliao, Linkou Dist., New Taipei City 244, Taiwan(R.O.C.)                      Tel: +886-2172-1000 Fax: +886-2172-1322                 </div> </div> <div style="text-align: right; font-size: 10px; margin-top: 10px;">Date: 2023-05-11</div>  <table border="1" style="width:100%; border-collapse: collapse; font-size: 8px; margin-top: 10px;"> <thead> <tr> <th>Freq</th> <th>Level</th> <th>Read</th> <th>Limit</th> <th>Over</th> <th>APos</th> <th>TPos</th> <th>Remark</th> <th>Pol/Phase</th> <th>Note</th> </tr> <tr> <th>MHz</th> <th>dBuV/m</th> <th>dBuV</th> <th>dB/m</th> <th>dBuV/m</th> <th>dB</th> <th>cm</th> <th>deg</th> <th></th> <th></th> </tr> </thead> <tbody> <tr><td>1</td><td>0.15</td><td>44.56</td><td>26.43</td><td>18.13</td><td>104.00</td><td>-59.52</td><td>100</td><td>221 Peak</td><td>Open</td></tr> <tr><td>2</td><td>0.45</td><td>41.36</td><td>22.54</td><td>18.82</td><td>94.57</td><td>-53.21</td><td>100</td><td>184 Peak</td><td>Open</td></tr> <tr><td>3</td><td>8.21</td><td>33.76</td><td>12.95</td><td>20.81</td><td>69.50</td><td>-35.74</td><td>100</td><td>25 Peak</td><td>Open</td></tr> <tr><td>4</td><td>13.94</td><td>35.65</td><td>13.82</td><td>21.83</td><td>69.50</td><td>-33.85</td><td>100</td><td>191 Peak</td><td>Open</td></tr> <tr><td>5</td><td>18.84</td><td>36.48</td><td>14.32</td><td>22.16</td><td>69.50</td><td>-33.02</td><td>100</td><td>360 Peak</td><td>Open</td></tr> <tr><td>6</td><td>22.42</td><td>36.26</td><td>14.00</td><td>22.26</td><td>69.50</td><td>-33.24</td><td>100</td><td>13 Peak</td><td>Open</td></tr> </tbody> </table>	Freq	Level	Read	Limit	Over	APos	TPos	Remark	Pol/Phase	Note	MHz	dBuV/m	dBuV	dB/m	dBuV/m	dB	cm	deg			1	0.15	44.56	26.43	18.13	104.00	-59.52	100	221 Peak	Open	2	0.45	41.36	22.54	18.82	94.57	-53.21	100	184 Peak	Open	3	8.21	33.76	12.95	20.81	69.50	-35.74	100	25 Peak	Open	4	13.94	35.65	13.82	21.83	69.50	-33.85	100	191 Peak	Open	5	18.84	36.48	14.32	22.16	69.50	-33.02	100	360 Peak	Open	6	22.42	36.26	14.00	22.26	69.50	-33.24	100	13 Peak	Open
Freq	Level	Read	Limit	Over	APos	TPos	Remark	Pol/Phase	Note																																																																																																																																																								
MHz	dBuV/m	dBuV	dB/m	dBuV/m	dB	cm	deg																																																																																																																																																										
1	0.01	54.52	36.00	17.72	127.60	-73.08	100	360 Peak	Open																																																																																																																																																								
2	0.01	53.61	35.64	17.97	124.97	-71.36	100	197 Peak	Open																																																																																																																																																								
3	0.03	59.40	40.45	18.95	119.13	-59.73	100	177 Peak	Open																																																																																																																																																								
4	0.04	47.36	28.20	19.16	115.67	-68.31	100	176 Peak	Open																																																																																																																																																								
5	0.05	45.95	26.93	19.02	112.95	-67.00	100	73 Peak	Open																																																																																																																																																								
6	0.07	42.84	23.29	18.75	111.30	-69.26	100	192 Peak	Open																																																																																																																																																								
Freq	Level	Read	Limit	Over	APos	TPos	Remark	Pol/Phase	Note																																																																																																																																																								
MHz	dBuV/m	dBuV	dB/m	dBuV/m	dB	cm	deg																																																																																																																																																										
1	0.15	44.56	26.43	18.13	104.00	-59.52	100	221 Peak	Open																																																																																																																																																								
2	0.45	41.36	22.54	18.82	94.57	-53.21	100	184 Peak	Open																																																																																																																																																								
3	8.21	33.76	12.95	20.81	69.50	-35.74	100	25 Peak	Open																																																																																																																																																								
4	13.94	35.65	13.82	21.83	69.50	-33.85	100	191 Peak	Open																																																																																																																																																								
5	18.84	36.48	14.32	22.16	69.50	-33.02	100	360 Peak	Open																																																																																																																																																								
6	22.42	36.26	14.00	22.26	69.50	-33.24	100	13 Peak	Open																																																																																																																																																								

Spurious Emissions, Tx Mode, 30MHz ~ 1GHz

EUT with all RF functions

Horizontal

Vertical



TUV Rheinland Taiwan Ltd.  
No. 458-18, Sec 2, Fenliao, Linkou Dist., New Taipei City 244, Taiwan(R.O.C.)  
Tel: +886-2172-1000 Fax: +886-2172-1322

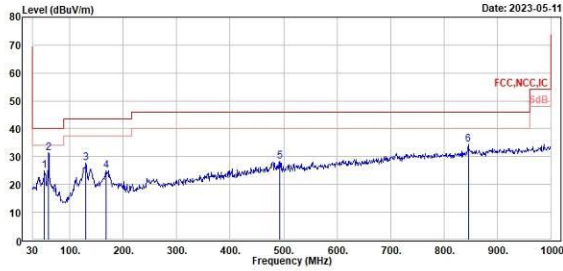

Peak	Freq	Level	Read	Limit	Over	APos	TPos	Remark	Pol/Phase	Note
	MHz	dBuV/m	Level	Line	Limit	cm	deg			
1	52.31	24.07	31.79	-6.92	40.00	-15.13	400	32 Peak	Horizontal	
2	60.07	31.26	38.94	-7.68	40.00	-8.74	100	152 Peak	Horizontal	
3	129.91	27.53	36.68	-9.15	43.50	-15.97	200	263 Peak	Horizontal	
4	167.74	24.92	31.92	-7.00	43.50	-18.58	200	287 Peak	Horizontal	
5	492.69	28.36	31.35	-2.99	46.00	-17.64	200	96 Peak	Horizontal	
6	845.77	34.43	30.73	3.70	46.00	-11.57	300	64 Peak	Horizontal	



TUV Rheinland Taiwan Ltd.  
No. 458-18, Sec 2, Fenliao, Linkou Dist., New Taipei City 244, Taiwan(R.O.C.)  
Tel: +886-2172-1000 Fax: +886-2172-1322

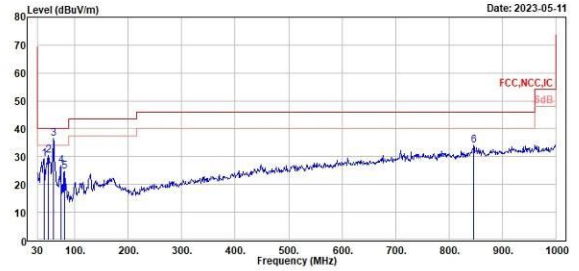

Peak	Freq	Level	Read	Limit	Over	APos	TPos	Remark	Pol/Phase	Note
	MHz	dBuV/m	Level	Line	Limit	cm	deg			
1	41.64	29.23	37.00	-7.77	40.00	-10.77	200	232 Peak	Vertical	
2	50.37	30.37	37.27	-6.90	40.00	-9.63	100	184 Peak	Vertical	
3	60.07	36.49	44.17	-7.68	40.00	-3.51	200	36 Peak	Vertical	
4	73.65	26.73	37.51	-10.78	40.00	-13.27	200	223 Peak	Vertical	
5	80.44	24.56	36.79	-12.23	40.00	-15.44	400	105 Peak	Vertical	
6	846.74	34.09	30.39	3.70	46.00	-11.91	100	275 Peak	Vertical	

Mains Conducted Emission, (150kHz ~ 30MHz)

