

ANCHEER

**FOLDING
TREADMILL**



Contents

Product brief introduction-----	01
How to install APP-----	02
Safety cautions and warnings-----	03
Parameter and packing list -----	07
Assembly guidance -----	08
Remote control instructions-----	13
Exercise advises and plan -----	14
Product instruction -----	15
Maintenance -----	17
Common malfunctions and solution----	22

Installation video

<https://youtu.be/JshGc7ubRok>

Product Instruction

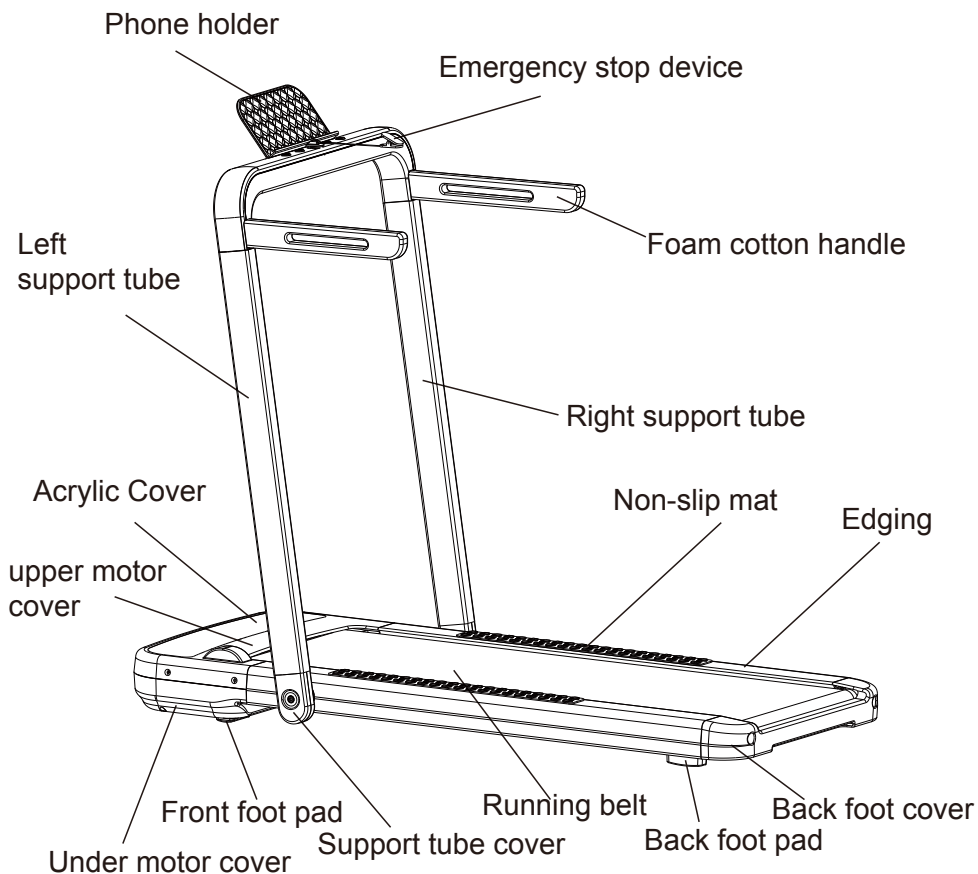

How to install APP

Scan the QR code on the right place



↓

Shift to APP store to download the APP and install it;

↓

Run the APP and follow the instructions to authorize it

↓

If this is your first time to login, please register with your phone number or mail address

↓

Start to use the APP

Please note when you are registering:
Please use correct mail address or phone number to make sure you can find your user name and password.

Caution!

Please read this manual carefully before using the product and take care to follow issues:

This treadmill should be used indoor, do not let this product be soaked and keep it away from water, do not put other things on the treadmill. Please take the proper sports gear and do warming up before use the treadmill, do not use the treadmill on bare feet.

The power plug must be grounded and use the dedicated circuit, do not share the circuit with other electric equipment.

Kids should stay away from the treadmill to avoid the unexpected situation.

Do not use the treadmill overload and over time, or the motor, control panel, bearing, running belt, and board's life will be greatly shortened. Should do the regular maintenance to keep a treadmill in a good state. Reduce dust and keep certain humidity indoor to prevent electronic and control devices from interference by static electricity.

Please turn off the treadmill after using it.

Please make sure air circulation when you are using the treadmill.

Clamp the emergency switch to your cloth to make sure the treadmill can be stopped if meet the unexpected situation.

Please stop doing exercise if you feel uncomfortable and consult your doctor.

Please keep the silicone oil away from a kid after using it to avoid eating accident.

Warning:

To avoid the accident and injured, please follow following issues:

Please check your sports gear and make sure the zipper is a lock.

Do not wear cloth which is easy to be hooked by the treadmill.

Do not put the power cord near the heat source.

Do not let the kid play with or play near a treadmill.

Do not use the treadmill outdoor.

Must unplug the treadmill before moving it.

Never try to disassemble the product if you are not a professional maintainer, or it will cause a very bad consequence.

The treadmill can only be used in the 20A circuit.

Only one person use it at one time, do not use it with two people and more.

Warning! Must!

Please consult your doctor if you are under therapy or have any one of the following issues:

(1) If you are suffering waist pain or hurt leg, waist or neck before, or have perceived obstacle to leg, waist, neck, and hand(also include disc herniation, Spondylolisthesis, Cervical protrusion).

(2) Deformed arthritis, rheumatism, gout.

(3) Osteoporosis or bone abnormality

(4) Circulatory system disorder(heart disease, vascular disease, high blood pressure).

(5) Respiratory organ disorder.

(6) Implant cardiac pacemaker or other electronic equipment.

(7) Malignant tumor.

(8) Thrombosis, serious arterial lipoma, acute venous lipoma and other blood circulation diseases or skin infections.

(9) Perceived obstacles caused by diabetes.

(10) Wounded on skin.

(11) Sick or fever(38–C or higher temperature).

(12) Spine abnormality or bending.

(13) Pregnant women or women are in the menstrual period.

- (14) Unhealthy and need rest.
- (15) Obvious bad condition.
- (16) For physical recovery purpose.
- (17) Other bad feeling expects above situations.

All issues above may cause unexpected conditions and may harm the body. Please stop doing exercise if you feel waist pain, dizzy, Palpitations or another abnormal feeling, consult your fitness coach or a doctor.

Kids must not use this product. The kid should be kept away from the product, or it may cause unexpected hurting risk.

Please make sure no other people or pets around the product when you are taking, packing, or sliding the product.

! Forbidden!

Never use if you found the shell is broken and off (inside parts are exposed) or the welding point is broken. Or it may cause an unexpected condition.

Never jump on and off the product when you are using, it may cause falling and injured.

Never store the product outdoor, near the bathroom, or any place where is damp.

Never use or store the product under direct sunlight, near stove, electric blanket, or other heating supply equipment, or it may cause electric shock or fire accidents.

Never use the product when you found power cord or plug is broken or socket slack, or it may cause electric shock, short circuit or fire accident

Never break or twist the power cord, also never put things on the wire to avoid electric shock or fire accident

Never use the product with two or more people at the same time, keep others way when using the product, or it may cause an unexpected situation or falling accident.

Never use the product if the user can not express self-consciousness or can not operate the product by himself/herself. Or it may cause an unexpected situation.

Keep the product away from water or other liquid, especially the main base. Or it may cause electric shock or fire accident

Never do intense exercise if you don't exercise usually. Do not use it after a meal, fatigue, or another uncomfortable state, or it may be harmful to your health.

This product is only for home use, never use it at school, stadium or other a public place or it may cause unexpected situations.

Never use the product if you are eating or doing other behavior, also never use it after drinking, or it may cause an accident or injured.

ever take your watch, bracelet, mobile phone, and other valuable objects with you to avoid damage, also take off your keys and knife to avoid hurting yourself.

Please do check the power cord whether there is needle, garbage or other wet things before using to avoid electric shock, short circuit or fire accident

Never touch the plug with a wet hand to avoid electric shock.

Please turn the power switch to off position and unplug the product if do not use it for a period to avoid electric shock or fire accident caused by insulation deterioration

Grounding explanation

This product must be grounding, it can greatly reduce the risk of electric shock when the product is dysfunction.

The plug of this product is grounding standard, please use a local legal grounding power source to connect the product

! Dangerous!

It may cause an electric shock if the product is not grounding properly.

Please ask a professional electrician to check if you are not sure whether the grounding is correct. Never modify the plug if it can not fit your power source, please ask a professional electrician to install a proper power source.

Never use transfer plug, this product must connect to a power source with grounding function.

Parameter and packing list

Paramete					
No.	Parameter		Descriptio		
1	Voltage		110V/60H		
2	Motor		81#/4800rpm/2.25HP		
3	Operating ways		Acrylic touching operation, button, phone APP, remote control.		
4	Display		LED display , phone APP		
5	Expanded		1265*645*115mm (L*W*H)		
6	Speed range		Normal 0.6-7.5 mile/h,Folded 0.6-2.5 mile/h		
7	Running area on		400*1000mm (W*L)		
8	N/G weight		Net weight: 26.5kg Gross weight: 31.5kg		
9	Package meas		Out package meas 1415*735*150mm		
10	Max Loading Weight		265LBS		
Packing					
No.	Name	Quantit	No.	Name	Quantit
1	base	1pcs	2	spare parts	1pcs
Spare parts					
N	Name				Quantity
1	Allen wrench (6#、5#)				1
2	Silicone oil				1
3	Manual				1
4	Emergency stop device				1
5	Remote control (watch style)				1
6	Phone holder				1
7	M6*60 screws				4

Assembly Guidance

How to put up the treadmill

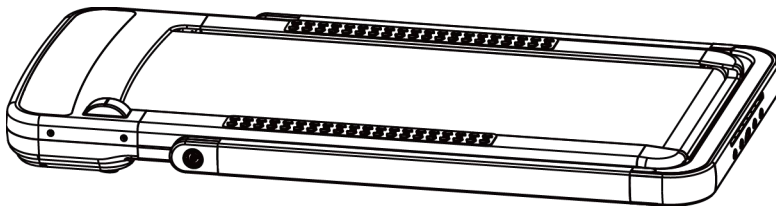

Step 1

Take the product out from the carton, then take off the PE bag and lay it on the flat ground.

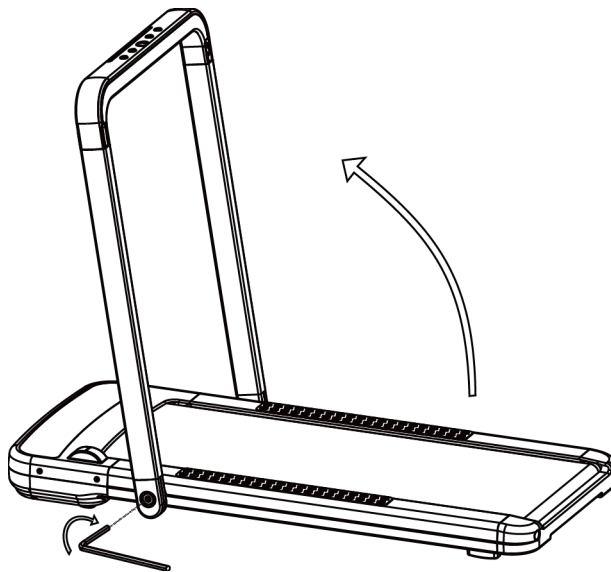

Step 2

Stand the supporting tube and move it to the right place(follow the picture shows), then use 6# Allen wrench to lock the tube in the middle of the tube cover in a clockwise direction(the other side is the same), when the supporting tube can not be shaken means ok.

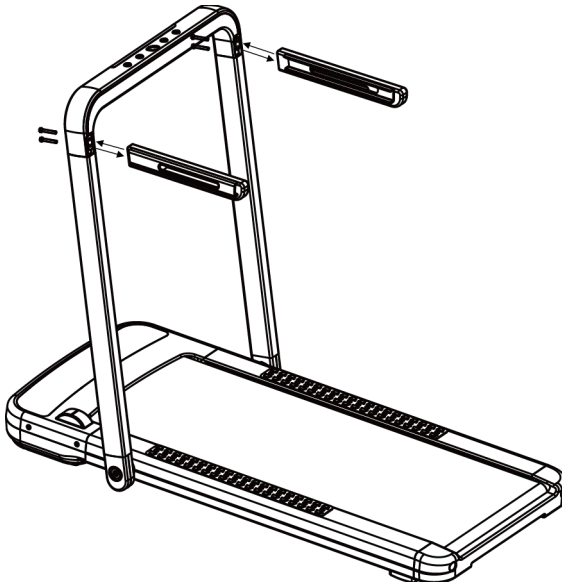

Step 3

Use 5# Allen wrench to assembly left and right handles, then fix them with M6*60 screws in a clockwise direction.

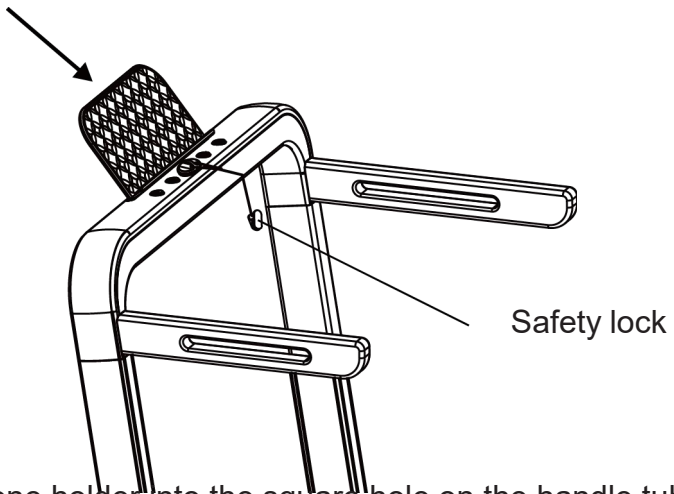

Step 4

Insert the phone holder into the square hole on the handle tube and fix it. Then put the emergency stop device in the middle of the yellow area.

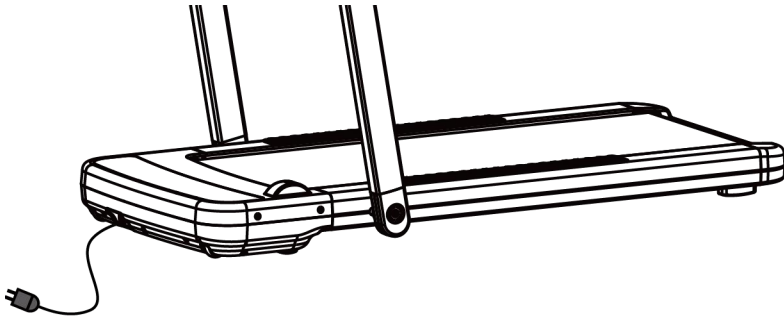

Step 5

Connect the plug to 120V power source and turn the switch to, if the indicator is on means the product is ready.

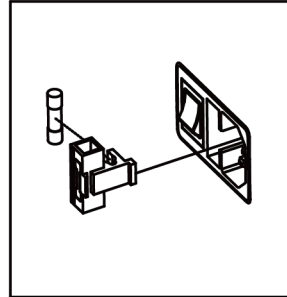
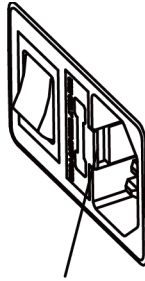
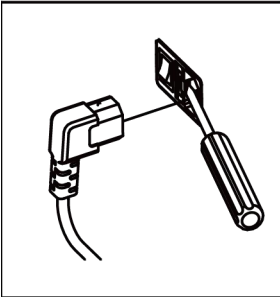

Slotted screwdriver position

Step 6

Change fuse

1. Unplug the product, use slotted screwdriver to take out the safe socket as picture 1.
2. Then replace a new fuse as picture 2.

2. Folded instructions

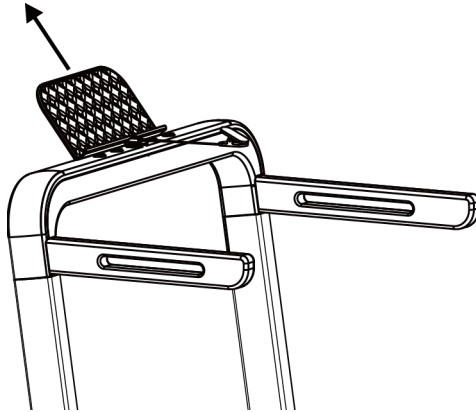

Step 1

Take off the phone holder when the product is put upstate, and keep the emergency stop device in the same state.

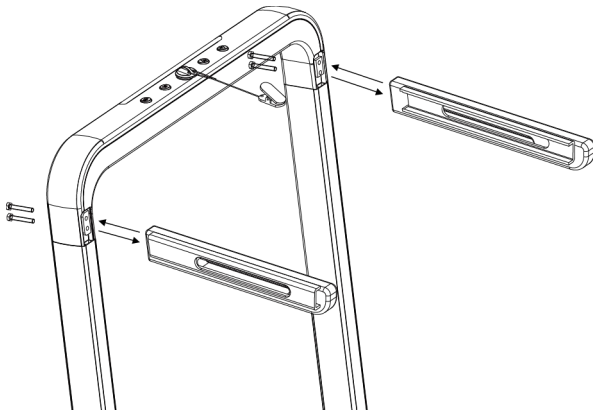

Step 2

Then use 5# Allen wrench to disassembly the left and right handles.

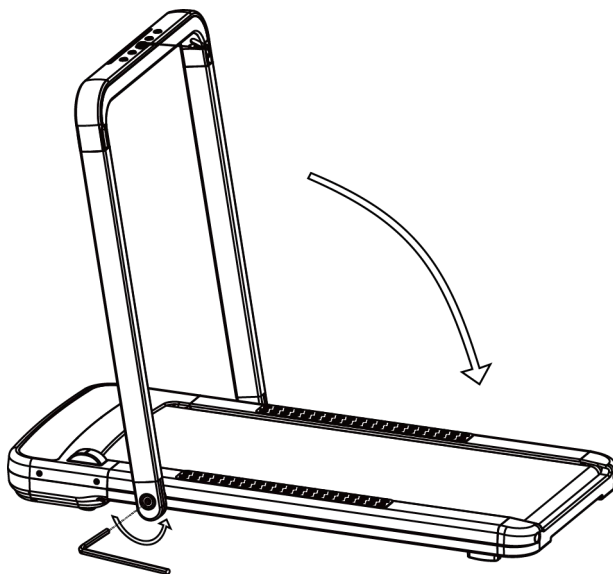

Step 3

Then use 6# Allen wrench to turn the supporting tube cover in the counterclockwise direction to lose the supporting tube, then put the supporting tube down slowly as the picture shows.

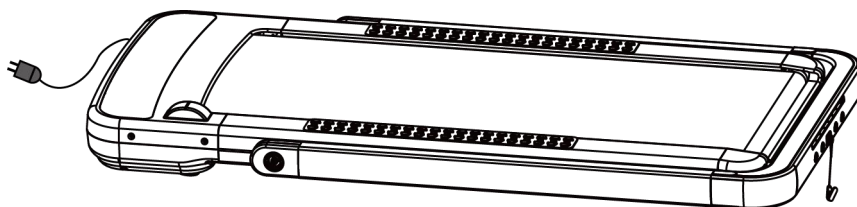

Step 4

Connect the plug to 110V power source (if the product is unplugged) and turn the switch to if the indicator is on means the product is ready.

Remarks: The folded is the low-speed mode, you can place it in front of your office desk. The speed range is 0.6-2.5 mile/h. Please stand on the belt first then use the remote control to start the product. Never step on the belt if the product is running, or it may cause an unexpected situation.

Remote control instructions:



Emergency stop key: It is only used for emergency stop, never use it as a normal stop key.

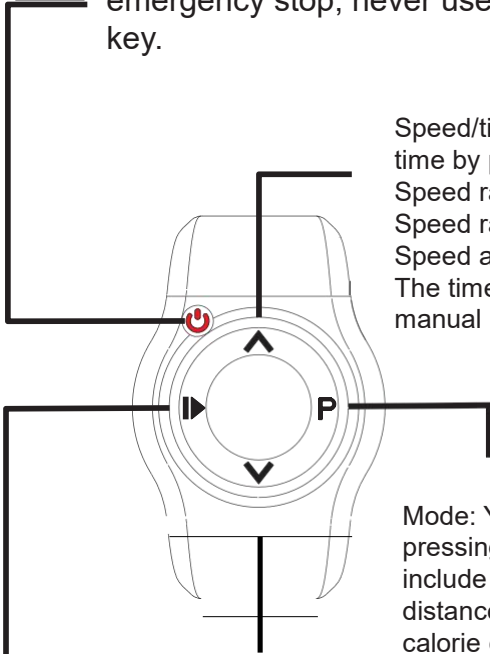

Speed/time+: You can increase speed and time by pressing this key.
Speed range input upstate(0.6-7.5 mile/h)
Speed range in folded state(0.6-2.5 mil/h)
Speed adjusting is unavailable in auto mode.
The time range is 5-99 minutes under manual mode.

Mode: You can switch different programs by pressing this key(p1-p12, H1-H3), also include time count down the program, distance count down the program, and calorie count down the program.

Speed/time-: You can reduce speed and time by pressing this key.
Speed range in put up state(0.6-7.5 mile/h) Speed range in folded state(0.6-2.5 mil/h) Speed adjusting is unavailable in auto mode.
The time range is 5-99 minutes under manual mode.

Start/stop key : Press this key to start/stop the product, there is a 3 seconds count down before the start.
The time range is 5-99 minutes under manual mode.

Remakes: The remote control signal range is 2.5 meters.

Exercise advises and plan

Warm-up: do warm-up exercise for 5~10 minutes before using this product

Breath: do not hold your breath when you are using this product, try to breathe by the nose, and coordinate with your movement. You should stop if breath too hasty.

Exercise frequency: muscle should rest for 48 hours after exercising.

Intensity: it depends on a different individual, please increase the intensity gradually, the fatigue can be cured under this situation.

Diet: To protect the digestive system, please do not use this product in 1 hour after a meal, also do not take any food in the half-hour after exercise. Try to not drink water when doing exercise to reduce the visceral burden.

Stretching exercises: No matter what speed you will run, a first stretching exercise is necessary, it can improve muscle activity and reduce the risk of sports injured. So you can follow the following guidance after warming up, 5 times for each pose, and do it again after exercise.

1. Stretch down bend down relax shoulder and back then try to touch your feet, 3 times (picture 1).

2. Stretch legs sit on a mat, stretch one leg and keep the other to stay balance then try to touch your toes of the straight leg, stay the pose for 10~15 seconds then repeat to the other leg, 3 times (picture 2).

3. Stand and put your hands on the wall or table, then push your body down and stay 10~15 seconds, 3 times for each leg (picture 3).

4. Ankle joint stretch stand and hold something to keep balance, then pull one ankle to your Buttocks until you feel tense on leg muscle, stay 10~15 seconds, 3 times for each leg (picture 4).

5. Thigh stretch sit and keep feet against, then pull feet to groin, stay 10~15 seconds and do it for 3 times (picture 5).



Product instruction

Brief introduction

It is an easy operating-panel, it does not require a complicated operation.

Vocabulary explanation: Treadmill related: Speed

Sports-related: distance, calorie, time

Mode: manual mode and auto mode

Manual mode: free adjusted mode without default data

Auto mode: the mode with default data

LED display

1.SPEED

2.TIME

3.CALORIE/DISTANCE

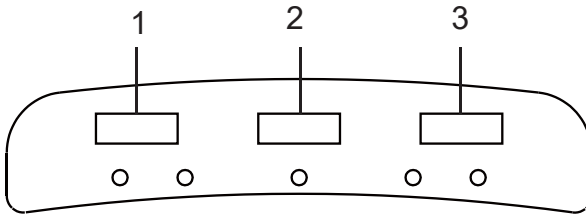

Keys

Keys on the product:

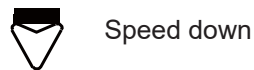

Parameters of put up state

LCD will display below contents

- 1.Voltage: 110V/60Hz
- 2.Minimum speed of 0.6 Mile/h
- 3.Maximum speed 7.5Mile/h
4. Under manual mode the minimum exercise time is 5 minutes, the maximum exercise time is 99 minutes.
5. Under auto mode, the maximum exercise time is 99 minutes.
6. Under auto mode, the maximum calorie is 999 K-cal.

Parameters of the folded state

- 1.Voltage: 110V/60Hz
- 2.Minimum speed of 0.6 Mile/h
- 3.Maximum speed 2.5Mile/h
4. Under manual mode the minimum exercise time is 5 minutes, the maximum exercise time is 99 minutes.
5. Under auto mode, the maximum exercise time is 99 minutes.
6. Under auto mode, the maximum calorie is 999 K-cal.

Mode description

Auto mode under put upstate:

Please check the plug, emergency stop device and switch and make sure all are ok before using the product. Turn on the product the display will show 0:00, then press “start” the product will start to run after a 3 seconds count down, the display will show 0.6 miles. Speed, time, and calorie also start to count, the product will stop automatically after 99 minutes, you can adjust speed by pressing “speed+” and “speed-”, the minimum speed is 0.6mile/h, the maximum speed is 7.5mile/h.

Auto mode under folded state:

Please check the plug, emergency stop device and switch and make sure all are ok before using the product. Turn on the product the display will show 0:00, then press “start” the product will start to run after a 3 seconds count down, the display will show 0.6 miles. Speed, time, and calorie also start to count, the product will stop automatically after 99 minutes, you can adjust speed by pressing “speed+” and “speed-”, the minimum speed is 0.6mile/h, the maximum speed is 2.5mile/h.

Manual mode:

1. Press “Program” to choose a program from P1-P12, the time will show 30minutes and keep blinking, press “Speed up” “Speed Down” to adjust the time, the minimum is 5 minutes and the maximum is 99minutes.

“PressStart/stop” the product will start to run after a 3 seconds count down, every time the product switches speed it will sound “di di di”.

2. Press “Program” on the control panel, the display will show H-1, the time will show 30minutes and keep blinking, press “Speed up” “Speed Down” to adjust the time, the minimum is 5 minutes and the maximum is 99minutes.

Press “PressStart/stop” the product will start to run after a 3 seconds count down.

3. Press “Mode” twice on the control panel, the display will show H-2, the distance will show 1.0 and keep blinking, press “Speed up” “Speed down” to adjust distance, the minimum is 1 mile and the maximum is 99 miles.

Press “PressStart/stop” the product will start to run after a 3 seconds count down.

4. Press “Mode” triple times on control panel, the display will show H-3, the calorie will show 50 and keep blinking, press “Speed up” “Speed down” to adjust calorie, the minimum is 20 kcal and the maximum is 999 kcal. Press “PressStart/stop” the product will start to run after a 3 seconds count down.

The speed and time of the pre-set programs are fixed and cannot be changed.

The default time for the pre-set programs is 30 minutes.

		Minutes										
		0-3	4-6	7-9	10-12	13-15	16-18	19-21	22-24	25-27	28-30	
Mode	P1	1	2	2	1	1	2	2	3	4	1	MPH
	P2	1	2	1	2	1	2	3	4	1	2	
	P3	1	2	1	2	3	2	4	2	1	2	
	P4	2	1	2	1	2	3	3	1	2	1	
	P5	2	1	1	2	2	1	2	3	2	2	
	P6	2	2	1	2	3	2	3	2	3	1	
	P7	2	1	2	2	1	2	1	2	3	1	
	P8	1	2	3	2	1	2	2	1	2	3	
	P9	2	2	4	2	4	2	2	3	2	1	
	P10	1	2	2	1	2	2	3	2	3	2	
	P11	2	3	4	4	3	3	2	3	3	1	
	P12	2	2	1	2	2	3	2	3	2	3	

Maintenance

Lubricating

The running belt must be lubricated with the specialized silicone oil after using it for a period.

1. Suggest lubricating frequency: Using time is less than 3 hours a week Lubricate it every 5 month

Using time is 4-7 hours a week Lubricate it every 2 month

Using time is over 7 hours a week Lubricate it every month

It will not be better if it is over lubricating, but reasonable lubricating can be an important factor to increase the life of the treadmill

2.How to do the lubricating

To check whether your treadmill needs lubricating, you can hold the running belt and put the other hand to touch the bottom center of the running belt, if you can feel the wet silicone oil that means it does not need lubricating. If you feel the running belt is very dry that means your treadmill needs a lubricating.

A. How to lubricating (as picture) B.Stop and fold the treadmill

C.Raise the running belt on the base, then try to put the silicone oil pot under the running belt and smear the silicone oil on the belt and both side of the treadmill, then set 1KM/H to make sure silicone oil lubricates every well, you can stop the running belt from left to right to improve the lubricating effect.

running belt

running board

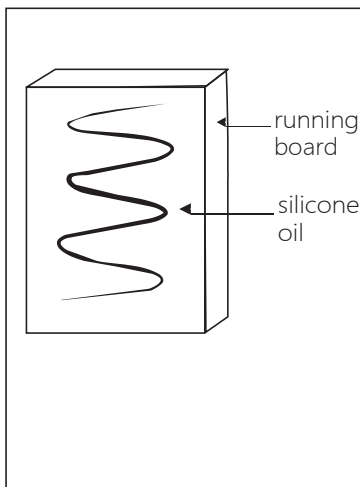

3. Adjusting the elastic tendency of running belt

Every treadmill must set the elastic tendency before it leaves the factory and after assembly, but it will become loose after using a period.

Just like it will be stuck or slide sometimes, you can turn the adjusting bolt in a clockwise direction, semi-circle a time (left and right at the same time) to adjust the running belt. Don't make it too loose or too tight, or the running belt will slide or make the motor overload.

4. Running belt deviating.

All running belt is in the right place when it is packaged. But some factors will cause this situation.

1) The treadmill is not set flat

2) User does not step on the center of the running belt

3) Caused by 1 or 2 is easy to be solved, just set the treadmill flat and let it idle for several minutes can solve the problem.

If the deviating still exist, you can use the 6mm Allen wrench to adjust it in a quarter turn.

Deviating is not in the warranty scale, the user can maintain it as follow instructions. But please fix it as soon as you find the problem or it may break the running belt.



If deviating turns to the right, then turn the left screw in a counterclockwise direction, Turn the right screw in a clockwise direction.



If deviating turns to left, then turn the left screw in clockwise direction, turn the right screw in counterclockwise direction.

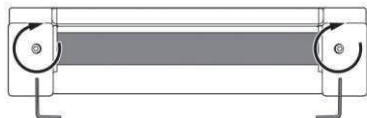

Turn the left screw in a clockwise direction with Allen wrench.



Turn the left screw in counterclockwise direction with Allen wrench.

1. Running belt slipping: The running belt may slip or have an unexpected stop in working time

2. Adjust the belt: Adjust the screws around the belt in a clockwise direction for 3 rounds, then adjust the belt as the belt deviation until the belt return to the middle of the base.

Common malfunction and solution

Error	Malfuncti	Cause	Solutions
E02	Motor over voltage protection	<ol style="list-style-type: none"> 1.Your local power voltage is unstable with much high peak voltage 2.Wrong preset wheel diameter value; 3.Control panel is under malfunction; 	<ol style="list-style-type: none"> 1.Need to add a filter regulator to keep voltage stable; 2.Reset the wheel diameter value to fit the rated voltage; 3.Replace a new control panel.
E03	Product over-current protection	<ol style="list-style-type: none"> 1.The product is over loaded; 2.There is foreign matter stuck in motor or rolling axe; 3.The roller is not lubricated enough and the resistance increases. 4.Control panel is under malfunction; 5.The motor is under malfunction and the resistance increases. 	<ol style="list-style-type: none"> 1.Reduce load, do not let it over rated load; 2.Take out the foreign matter; 3.Increase lubricant, 4.Change a new control panel 5.Change a new moto
E04	Motor malfunction	<ol style="list-style-type: none"> 1.Motor is disconnected 2.Motor is open circuit, broken; 3.Control panel is open circuit, broken; 	<ol style="list-style-type: none"> 1.Reconnect and make motor lines firmer; 2.Change a new motor 3.Change a new control panel
E06	Signal error	<ol style="list-style-type: none"> 1.Main single wire is lose between up and down control panel. 2.Main single wire is broken between up and down control panel. 3.Electrical head is broken; 4.Control panel is broken; 	<ol style="list-style-type: none"> 1.Reconnect the signal line; 2.Change a new signal line; 3.Change a new electrical head; 4.Change a new control panel;
E07/---	Emergency stop device is disconnected	<ol style="list-style-type: none"> 1.Emergency stop device is not in the right place; 2.The induction line of emergency stop device is broken; 3.The interface of electrical head is broken; 	<ol style="list-style-type: none"> 1.Put the emergency stop device on the right place 2.Change a new induction line; 3.Change a new electrical head;
E0C	Explosion-proof protection	Power transistor is breakdown, control penal is malfunction;	Change a new control panel;

Other malfunctions and solutions

1.No display

a: Check whether the power is plug correctly and switch on, whether the control is a fuse blown;

b: Whether the 4core line of control panel and the display is connected correctly;

c: Whether the control and transformer are intact.

2. The motor does not work

a: Please check all the wires are connected well;

b: Please check the error code displayed on the electrical head; Whether your hand contact the sensor close enough

3. The touch screen is insensitive: a: whether the touch screen is moist. b: Whether sweat in on your hands

FCC compliance statement:

This device complies with Part 15 of the FCC Rules. Operation is subject to the following two conditions: (1) this device may not cause harmful interference, and (2) this device must accept any interference received, including interference that may cause undesired operation.

Caution: The user is cautioned that changes or modifications not expressly approved by the party responsible for compliance could void the user's authority to operate the equipment.

Note: This equipment has been tested and found to comply with the limits for a Class B digital device, pursuant to part 15 of the FCC Rules. These limits are designed to provide reasonable protection against harmful interference in a residential installation.

This equipment generates, uses and can radiate radio frequency energy and, if not installed and used in accordance with the instructions, may cause harmful interference to radio communications. However, there is no guarantee that interference will not occur in a particular installation. If this equipment does cause harmful interference to radio or television reception, which can be determined by turning the equipment off and on, the user is encouraged to try to correct the interference by one or more of the following measures:

- Reorient or relocate the receiving antenna.
- Increase the separation between the equipment and receiver.
- Connect the equipment into an outlet on a circuit different from that to which the receiver is connected.
- Consult the dealer or an experienced radio/TV technician for help.

The device has been evaluated to meet general RF exposure requirement. The device can be used in portable exposure condition without restriction.

FCC ID: 2BB88-JF-H-40J

ANCHEER

Made in China