



# FCC TEST REPORT

## FCC ID:2BB6T-TB40D

Report Number..... : ZKT-241105L14648E-1

Date of Test..... September 30, 2024 ~ Oct. 09, 2024

Date of issue ..... : Oct. 09, 2024

Total number of pages ..... 38

Test Result ..... : PASS

Testing Laboratory..... : **Shenzhen ZKT Technology Co., Ltd.**

Address ..... : 1/F, No. 101, Building B, No. 6, Tangwei Community Industrial Avenue, Fuhai Street, Bao'an District, Shenzhen, China

Applicant's name ..... : Funan County Beizhiyin Electronic Technology Co., Ltd

Address : No. 6, Weisan Road, Funan County Economic Development Zone, Fuyang City, Anhui Province, China

Manufacturer's name : Funan County Beizhiyin Electronic Technology Co., Ltd

Address : No. 6, Weisan Road, Funan County Economic Development Zone, Fuyang City, Anhui Province, China

Test specification:

Standard : FCC CFR Title 47 Part 15 Subpart C Section 15.249  
ANSI C63.10:2013

Test procedure..... : /

Non-standard test method ..... : N/A

**Test Report Form No.** ..... : TRF-EL-111\_V0

**Test Report Form(s) Originator** .... : ZKT Testing

**Master TRF** ..... : Oct. 09, 2024

This device described above has been tested by ZKT, and the test results show that the equipment under test (EUT) is in compliance with the FCC requirements. And it is applicable only to the tested sample identified in the report.

This report shall not be reproduced except in full, without the written approval of ZKT, this document may be altered or revised by ZKT, personal only, and shall be noted in the revision of the document.

Product name..... : Smart Watch

Trademark ..... : N/A

Model/Type reference ..... : TB39, TB40D, TB62D, TB67, TB87, TB90, TB92, TB95, TB97, TB98

Ratings..... : DC 5.0V from adapter or DC 3.7V from Li-battery



Testing procedure and testing location:

Testing Laboratory .....: Shenzhen ZKT Technology Co., Ltd.

Address.....: 1/F, No. 101, Building B, No. 6, Tangwei Community Industrial Avenue, Fuhai Street, Bao'an District, Shenzhen, China

Tested by (name + signature) .....: Jim Liu

Reviewer (name + signature).....: Jackson Fang

Approved (name + signature) .....: Lake Xie





Table of Contents

Page

<b>1. VERSION .....</b>	<b>5</b>
<b>2. SUMMARY OF TEST RESULTS.....</b>	<b>6</b>
2.1 TEST FACILITY .....	7
2.2 MEASUREMENT UNCERTAINTY .....	7
<b>3. GENERAL INFORMATION .....</b>	<b>8</b>
3.1 GENERAL DESCRIPTION OF EUT .....	8
3.2 DESCRIPTION OF TEST MODES.....	10
3.3 BLOCK DIGRAM SHOWING THE CONFIGURATION OF SYSTEM TESTED .....	10
3.4 DESCRIPTION OF SUPPORT UNITS(CONDUCTED MODE).....	11
3.5 EQUIPMENTS LIST FOR ALL TEST ITEMS.....	12
<b>4. EMC EMISSION TEST .....</b>	<b>13</b>
4.1 CONDUCTED EMISSION MEASUREMENT .....	13
4.1.1 POWER LINE CONDUCTED EMISSION Limits .....	13
4.1.2 TEST PROCEDURE .....	13
4.1.3 DEVIATION FROM TEST STANDARD .....	13
4.1.4 TEST SETUP .....	14
4.1.5 EUT OPERATING CONDITIONS .....	14
4.2 RADIATED EMISSION MEASUREMENT.....	17
4.2.1 RADIATED EMISSION LIMITS.....	17
4.2.2 TEST PROCEDURE .....	18
4.2.3 DEVIATION FROM TEST STANDARD .....	18
4.2.4 TEST SETUP .....	18
4.2.5 EUT OPERATING CONDITIONS .....	19
<b>5. BANDWIDTH OF FREQUENCY BAND EDGE.....</b>	<b>24</b>
<b>6. BANDWIDTH OF FREQUENCY BAND EDGE.....</b>	<b>26</b>
6.1 TEST REQUIREMENT: .....	26
6.2 TEST PROCEDURE .....	26
6.3 DEVIATION FROM TEST STANDARD .....	26
6.4 TEST SETUP .....	26
6.5 EUT OPERATING CONDITIONS .....	27
6.6 TEST RESULT .....	28
<b>7. CHANNEL BANDWIDTH .....</b>	<b>30</b>
7.1 APPLIED PROCEDURES / LIMIT .....	30
7.2 TEST PROCEDURE .....	30
7.3 DEVIATION FROM STANDARD .....	30



<b>Table of Contents</b>	<b>Page</b>
<b>7.4 TEST SETUP .....</b>	<b>30</b>
<b>7.5 EUT OPERATION CONDITIONS .....</b>	<b>30</b>
<b>7.6 TEST RESULT .....</b>	<b>31</b>
<b>8.ANTENNA REQUIREMENT.....</b>	<b>37</b>
<b>9. TEST SETUP PHOTO.....</b>	<b>38</b>
<b>10. EUT CONSTRUCTIONAL DETAILS.....</b>	<b>38</b>



**1.VERSION**

Report No.	Version	Description	Approved
ZKT-241105L14648E-1	Rev.01	Initial issue of report	Oct. 09, 2024



## 2. SUMMARY OF TEST RESULTS

Test procedures according to the technical standards:

FCC Part15 (15.249) , Subpart C			
Standard Section	Test Item	Judgment	Remark
FCC part 15.203	Antenna requirement	PASS	
FCC part 15.207	AC Power Line Conducted Emission	PASS	
FCC part15.249(a)	Field Strength of Fundamental	PASS	
FCC part 15.249	Fundamental &Radiated Spurious Emission Measurement	PASS	
FCC part 15.215 (c)	20dB Channel Bandwidth	PASS	
FCC part 15.205	Band Edge	PASS	

NOTE:

(1) "N/A" denotes test is not applicable in this Test Report



## 2.1 TEST FACILITY

Shenzhen ZKT Technology Co., Ltd.

Add. : 1/F, No. 101, Building B, No. 6, Tangwei Community Industrial Avenue, Fuhai Street, Bao'an District, Shenzhen, China

FCC Test Firm Registration Number: 692225

Designation Number: CN1299

IC Registered No.: 27033

## 2.2 MEASUREMENT UNCERTAINTY

The reported uncertainty of measurement  $y \pm U$  · where expanded uncertainty U is based on a standard uncertainty multiplied by a coverage factor of  $k=2$  · providing a level of confidence of approximately 95 % ·

No.	Item	Uncertainty
1	Conducted Emission Test	$\pm 1.38\text{dB}$
2	RF power conducted	$\pm 0.16\text{dB}$
3	Spurious emissions conducted	$\pm 0.21\text{dB}$
4	All emissions radiated(<1G)	$\pm 4.68\text{dB}$
5	All emissions radiated(>1G)	$\pm 4.89\text{dB}$
6	Temperature	$\pm 0.5^\circ\text{C}$
7	Humidity	$\pm 2\%$



### 3. GENERAL INFORMATION

#### 3.1 GENERAL DESCRIPTION OF EUT

Product Name:	Smart Watch
Model No.:	TB39, TB40D, TB62D, TB67, TB87, TB90, TB92, TB95, TB97, TB98
Model Different.:	All models the function, software and electric circuit are the same, only Product color, appearance, and model named different. Test sample model: TB39
Serial No.:	N/A
Hardware Version:	H1.0
Software Version:	S1.0
Sample(s) Status:	Engineer sample
Operation Frequency:	2402MHz-2480MHz
Channel Numbers:	79CH
Modulation Type:	GFSK, $\pi/4$ DQPSK, 8DPSK
Antenna Type:	PCB Antenna
Antenna gain:	2.09 dBi
Power supply:	DC 5.0V from adapter or DC 3.7V from Li-battery





Channel List							
Channel	Frequency (MHz)	Channel	Frequency (MHz)	Channel	Frequency (MHz)	Channel	Frequency (MHz)
00	2402	21	2423	42	2444	63	2465
01	2403	22	2424	43	2445	64	2466
02	2404	23	2425	44	2446	65	2467
03	2405	24	2426	45	2447	66	2468
04	2406	25	2427	46	2448	67	2469
05	2407	26	2428	47	2449	68	2470
06	2408	27	2429	48	2450	69	2471
07	2409	28	2430	49	2451	70	2472
08	2410	29	2431	50	2452	71	2473
09	2411	30	2432	51	2453	72	2474
10	2412	31	2433	52	2454	73	2475
11	2413	32	2434	53	2455	74	2476
12	2414	33	2435	54	2456	75	2477
13	2415	34	2436	55	2457	76	2478
14	2416	35	2437	56	2458	77	2479
15	2417	36	2438	57	2459	78	2480
16	2418	37	2439	58	2460		
17	2419	38	2440	59	2461		
18	2420	39	2441	60	2462		
19	2421	40	2442	61	2463		
20	2422	41	2443	62	2464		

错误！未指定书签。 TEST MODE

The EUT was programmed to be in continuously transmitting mode.

Channel List		
Test Channel	EUT Channel	Test Frequency (MHz)
Low	CH00	2402
Middle	CH39	2441
High	CH78	2480



### 3.2 DESCRIPTION OF TEST MODES

Transmitting mode	Keep the EUT in continuously transmitting mode
Remark: During the test, the test voltage was tuned from 85% to 115% of the nominal rated supply voltage, and found that the worst case was under the nominal rated supply condition. So the report just shows that condition's data.	

Test Software	BT_Tool
Power level setup	4dBm

### 3.3 BLOCK DIGRAM SHOWING THE CONFIGURATION OF SYSTEM TESTED

#### Radiated Emission

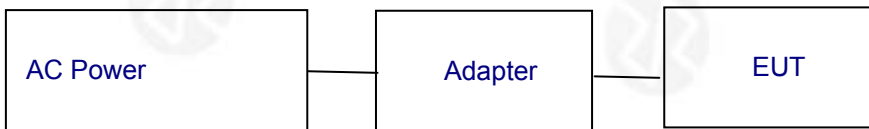

#### Conducted Spurious





### 3.4 DESCRIPTION OF SUPPORT UNITS(CONDUCTED MODE)

The EUT has been tested as an independent unit together with other necessary accessories or support units. The following support units or accessories were used to form a representative test configuration during the tests.

Item	Equipment	Mfr/Brand	Model/Type No.	Series No.	Note
E-1	Smart Watch	/	TB39	/	EUT
A-9	Adapter	/	MDY-11-EX	/	/

Item	Shielded Type	Ferrite Core	Length	Note
C-1	/	/	/	/

**Note:**

- (1) The support equipment was authorized by Declaration of Confirmation.
- (2) For detachable type I/O cable should be specified the length in cm in 『Length』 column.



3.5 EQUIPMENTS LIST FOR ALL TEST ITEMS

**Equipment List:**

Item	Equipment	Manufacturer	Type No.	Serial No.	Last calibration	Calibrated until
1	Spectrum Analyzer (9kHz-26.5GHz)	KEYSIGHT	9020A	MY55370835	Sep. 29, 2024	Sep. 28, 2025
2	Spectrum Analyzer (10kHz-39.9GHz)	R&S	FSQ	100363	Sep. 30, 2024	Sep. 29, 2025
3	EMI Test Receiver (9kHz-7GHz)	R&S	ESCI7	101169	Sep. 29, 2024	Sep. 28, 2025
4	Bilog Antenna (30MHz-1500MHz)	<b>Schwarzbeck</b>	VULB9168	N/A	Sep. 30, 2024	Sep. 29, 2025
5	Horn Antenna (1GHz-18GHz)	Agilent	AH-118	071145	Sep. 30, 2024	Sep. 29, 2025
6	Horn Antenna (15GHz-40GHz)	A.H.System	SAS-574	588	Sep. 30, 2024	Sep. 29, 2025
7	Loop Antenna	TESEQ	HLA6121	58357	Oct. 11, 2024	Oct. 10, 2025
8	Amplifier (30-1000MHz)	EM Electronics	EM330 Amplifier	060747	Sep. 29, 2024	Sep. 28, 2025
9	Amplifier (1GHz-26.5GHz)	Agilent	8449B	3008A00315	Sep. 29, 2024	Sep. 28, 2025
10	Amplifier (500MHz-40GHz)	Quanjuda	DLE-161	097	Sep. 30, 2024	Sep. 29, 2025
11	Test Cable	N/A	R-01	N/A	Sep. 30, 2024	Sep. 29, 2025
12	Test Cable	N/A	R-02	N/A	Sep. 30, 2024	Sep. 29, 2025
13	Test Cable	N/A	R-03	N/A	Sep. 30, 2024	Sep. 29, 2025
14	Test Cable	N/A	RF-01	N/A	Sep. 30, 2024	Sep. 29, 2025
15	Test Cable	N/A	RF-02	N/A	Sep. 30, 2024	Sep. 29, 2025
16	Test Cable	N/A	RF-03	N/A	Sep. 30, 2024	Sep. 29, 2025
17	ESG Signal Generator	Agilent	E4421B	N/A	Sep. 29, 2024	Sep. 28, 2025
18	Signal Generator	Agilent	N5182A	N/A	Sep. 29, 2024	Sep. 28, 2025
19	Magnetic Field Probe Tester	Narda	ELT-400	0-0344	Nov. 16, 2023	Nov. 15, 2024
20	Wideband Radio Communication Test	R&S	CMW500	106504	Sep. 30, 2024	Sep. 29, 2025
21	MWRF Power Meter Test system	MW	MW100-RPCB	N/A	Sep. 29, 2024	Sep. 28, 2025
22	D.C. Power Supply	LongWei	TPR-6405D	N/A	\	\
23	EMC Software	Frad	EZ-EMC	Ver.EMC-CON 3A1.1	\	\
24	RF Software	MW	MTS8310	V2.0.0.0	\	\
25	Turntable	MF	MF-7802BS	N/A	\	\
26	Antenna tower	MF	MF-7802BS	N/A	\	\



#### 4. EMC EMISSION TEST

##### 4.1 CONDUCTED EMISSION MEASUREMENT

Test Requirement:	FCC Part15 C Section 15.207
Test Method:	ANSI C63.10:2013
Test Frequency Range:	150KHz to 30MHz
Receiver setup:	RBW=9KHz, VBW=30KHz, Sweep time=auto

##### 4.1.1 错误! 未指定书签。POWER LINE CONDUCTED EMISSION Limits

FREQUENCY (MHz)	Limit (dBuV)		Standard
	Quas -peak	Average	
0.15 -0.5	66 - 56 *	56 - 46 *	FCC
0.50 -5.0	56.00	46.00	FCC
5.0 -30.0	60.00	50.00	FCC

Note:

(1) \*Decreases with the logarithm of the frequency.

##### 4.1.2 TEST PROCEDURE

- The EUT was placed 0.8 meters from the horizontal ground plane with EUT being connected to the power mains through a line impedance stabilization network (LISN). All other support equipments powered from additional LISN(s). The LISN provide 50 Ohm/ 50uH of coupling impedance for the measuring instrument.
- Interconnecting cables that hang closer than 40 cm to the ground plane shall be folded back and forth in the center forming a bundle 30 to 40 cm long.
- I/O cables that are not connected to a peripheral shall be bundled in the center. The end of the cable may be terminated, if required, using the correct terminating impedance. The overall length shall not exceed 1 m.
- LISN at least 80 cm from nearest part of EUT chassis.
- For the actual test configuration, please refer to the related Item –EUT Test Photos.

##### 4.1.3 DEVIATION FROM TEST STANDARD

No deviation



#### 4.1.4 TEST SETUP

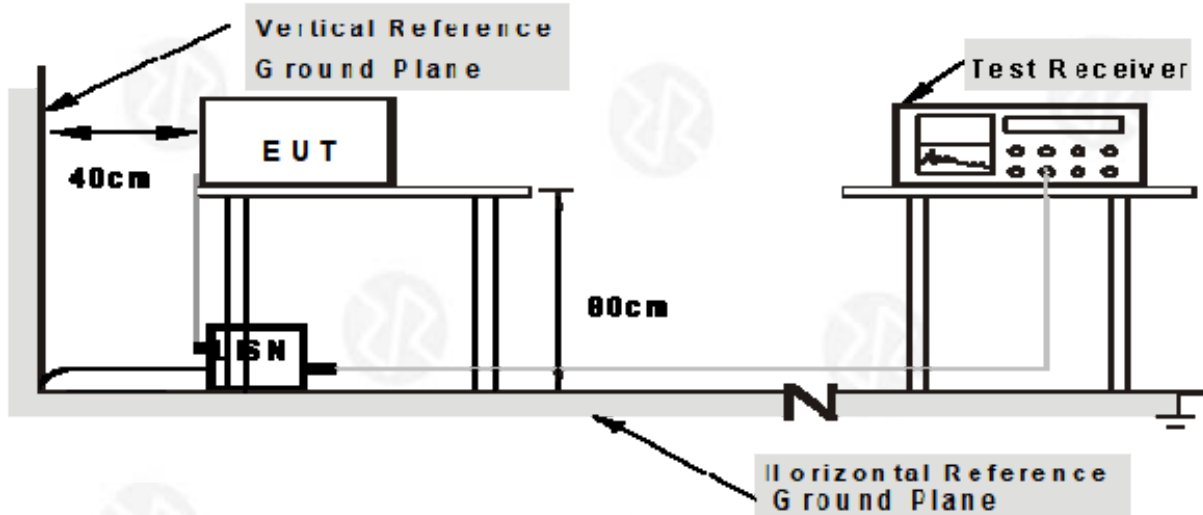

- Note: 1. Support units were connected to second LISN.**  
**2. Both of LISNs (AMN) are 80 cm from EUT and at least 80 from other units and other metal planes**

#### 4.1.5 EUT OPERATING CONDITIONS

The EUT was configured for testing in a typical fashion (as a customer would normally use it). The EUT has been programmed to continuously transmit during test. This operating condition was tested and used to collect the included data.

#### 4.1.6 Test Result



No.	Frequency (MHz)	QuasiPeak reading (dBuV)	Average reading (dBuV)	Correction factor (dB)	QuasiPeak result (dBuV)	Average result (dBuV)	QuasiPeak limit (dBuV)	Average limit (dBuV)	QuasiPeak margin (dB)	Average margin (dB)	Remark
1P	0.2660	28.47	16.58	10.08	38.55	26.66	61.24	51.24	-22.69	-24.58	Pass
2P	0.4220	31.05	19.93	10.07	41.12	30.00	57.41	47.41	-16.29	-17.41	Pass
3P	0.4940	34.09	17.22	10.08	44.17	27.30	56.10	46.10	-11.93	-18.80	Pass
4*	0.5580	38.01	24.93	10.07	48.08	35.00	56.00	46.00	-7.92	-11.00	Pass
5P	0.6140	28.64	16.55	10.06	38.70	26.61	56.00	46.00	-17.30	-19.39	Pass
6P	1.0300	28.06	13.21	10.15	38.21	23.36	56.00	46.00	-17.79	-22.64	Pass

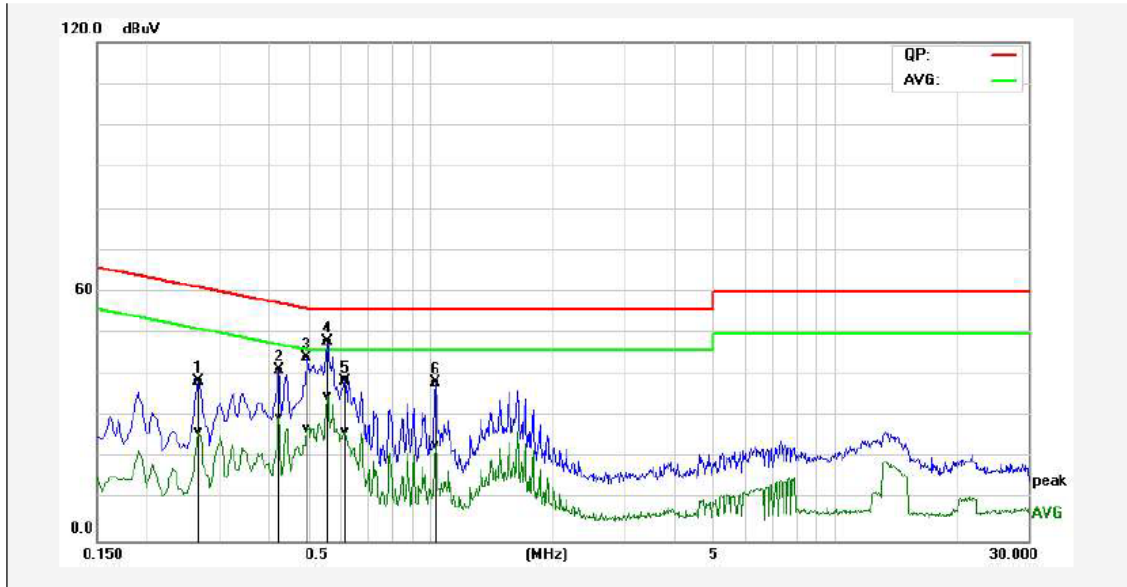

No.	Frequency (MHz)	QuasiPeak reading (dBuV)	Average reading (dBuV)	Correction factor (dB)	QuasiPeak result (dBuV)	Average result (dBuV)	QuasiPeak limit (dBuV)	Average limit (dBuV)	QuasiPeak margin (dB)	Average margin (dB)	Remark
1P	0.2660	28.47	16.58	10.08	38.55	26.66	61.24	51.24	-22.69	-24.58	Pass
2P	0.4220	31.05	19.93	10.07	41.12	30.00	57.41	47.41	-16.29	-17.41	Pass
3P	0.4940	34.09	17.22	10.08	44.17	27.30	56.10	46.10	-11.93	-18.80	Pass
4*	0.5580	38.01	24.93	10.07	48.08	35.00	56.00	46.00	-7.92	-11.00	Pass
5P	0.6140	28.64	16.55	10.06	38.70	26.61	56.00	46.00	-17.30	-19.39	Pass
6P	1.0300	28.06	13.21	10.15	38.21	23.36	56.00	46.00	-17.79	-22.64	Pass

Remark: Factor = Insertion Loss + Cable Loss, Result = Reading + Factor, Margin = Result – Limit.



Temperature:	26°C	Relative Humidity:	60%
Test Voltage:	AC 120V, 60Hz	Phase:	Neutral
Test Mode:	Transmitting mode of 8DPSK 2402MHz		

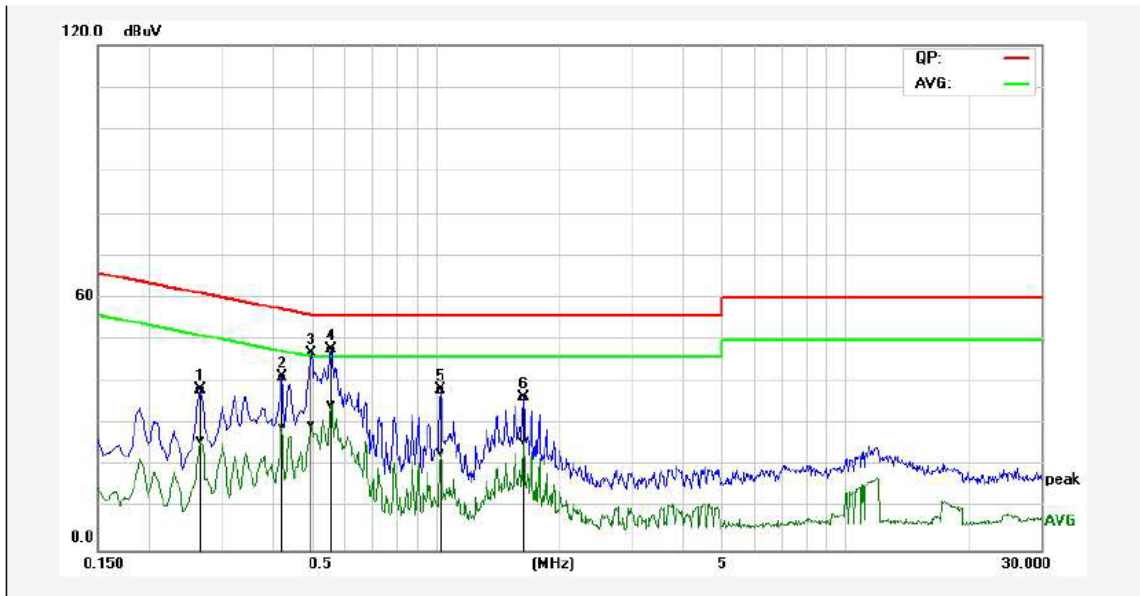

No.	Frequency (MHz)	QuasiPeak reading (dBuV)	Average reading (dBuV)	Correction factor (dB)	QuasiPeak result (dBuV)	Average result (dBuV)	QuasiPeak limit (dBuV)	Average limit (dBuV)	QuasiPeak margin (dB)	Average margin (dB)	Remark
1P	0.2660	28.28	16.27	10.08	38.36	26.35	61.24	51.24	-22.88	-24.89	Pass
2P	0.4220	31.07	19.04	10.07	41.14	29.11	57.41	47.41	-16.27	-18.30	Pass
3P	0.4980	36.72	19.74	10.08	46.80	29.82	56.03	46.03	-9.23	-16.21	Pass
4*	0.5580	37.90	24.52	10.07	47.97	34.59	56.00	46.00	-8.03	-11.41	Pass
5P	1.0300	28.02	13.23	10.15	38.17	23.38	56.00	46.00	-17.83	-22.62	Pass
6P	1.6420	26.27	15.85	10.17	36.44	26.02	56.00	46.00	-19.56	-19.98	Pass

Remark: Factor = Insertion Loss + Cable Loss, Result = Reading + Factor, Margin = Result – Limit.





#### 4.2 RADIATED EMISSION MEASUREMENT

Test Requirement:	FCC Part15 C Section 15.209				
Test Method:	ANSI C63.10:2013				
Test Frequency Range:	9kHz to 25GHz				
Test site:	Measurement Distance: 3m				
Receiver setup:	Frequency	Detector	RBW	VBW	Value
	9KHz-150KHz	Quasi-peak	200Hz	600Hz	Quasi-peak
	150KHz-30MHz	Quasi-peak	9KHz	30KHz	Quasi-peak
	30MHz-1GHz	Quasi-peak	100KHz	300KHz	Quasi-peak
	Above 1GHz	Peak	1MHz	3MHz	Peak
Peak		1MHz	10Hz	Average	

#### 4.2.1 RADIATED EMISSION LIMITS

Frequencies (MHz)	Field Strength (micorvolts/meter)	Measurement Distance (meters)
0.009~0.490	2400/F(KHz)	300
0.490~1.705	24000/F(KHz)	30
1.705~30.0	30	30
30~88	100	3
88~216	150	3
216~960	200	3
Above 960	500	3

#### LIMITS OF RADIATED EMISSION MEASUREMENT

FREQUENCY (MHz)	Limit (dBuV/m) (at 3M)	
	PEAK	AVERAGE
Above 1000	74	54

Notes:

- (1) The limit for radiated test was performed according to FCC PART 15C.
- (2) The tighter limit applies at the band edges.
- (3) Emission level (dBuV/m)=20log Emission level (uV/m).



#### 4.2.2 TEST PROCEDURE

- a. The measuring distance of at 3 m shall be used for measurements at frequency up to 25GHz. For frequencies above 1GHz, any suitable measuring distance may be used.
- b. The EUT was placed on the top of a rotating table 0.8 meters above the ground at a 3 meter semi-chamber test. The table was rotated 360 degrees to determine the position of the highest radiation.
- c. The height of the equipment or of the substitution antenna shall be 0.8m; above 1GHz, the height was 1.5m, the height of the test antenna shall vary between 1 m to 4 m. Both horizontal and vertical polarizations of the antenna are set to make the measurement.
- d. The initial step in collecting conducted emission data is a spectrum analyzer peak detector mode pre-scanning the measurement frequency range. Significant peaks are then marked and then Quasi Peak detector mode re-measured.
- e. If the Peak Mode measured value compliance with and lower than Quasi Peak Mode Limit, the EUT shall be deemed to meet QP Limits and then no additional QP Mode measurement performed.
- f. For the actual test configuration, please refer to the related Item –EUT Test Photos.
- g. For the radiated emission test above 1GHz:  
Place the measurement antenna away from each area of the EUT determined to be a source of emissions at the specified measurement distance, while keeping the measurement antenna aimed at the source of emissions at each frequency of significant emissions, with polarization oriented for maximum response.

The measurement antenna may have to be higher or lower than the EUT, depending on the radiation pattern of the emission and staying aimed at the emission source for receiving the maximum signal. The final measurement antenna elevation shall be that which maximizes the emissions. The measurement antenna elevation for maximum emissions shall be restricted to a range of heights of from 1 m to 4 m above the ground or reference ground plane.

Note:

Both horizontal and vertical antenna polarities were tested and performed pretest to three orthogonal axis. The worst case emissions were reported

#### 4.2.3 DEVIATION FROM TEST STANDARD

No deviation

#### 4.2.4 TEST SETUP

##### (A) Radiated Emission Test-Up Frequency Below 30MHz

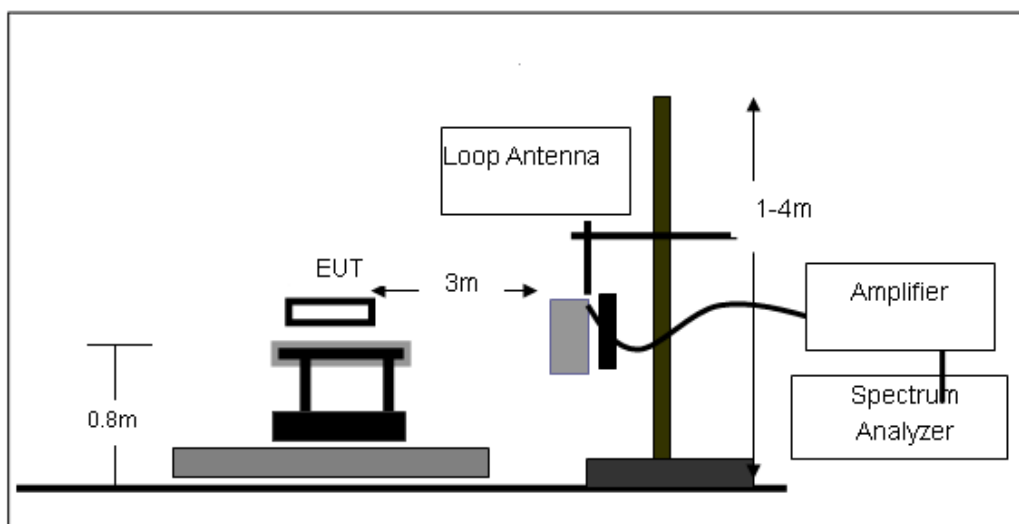



(B) Radiated Emission Test-Up Frequency 30MHz~1GHz

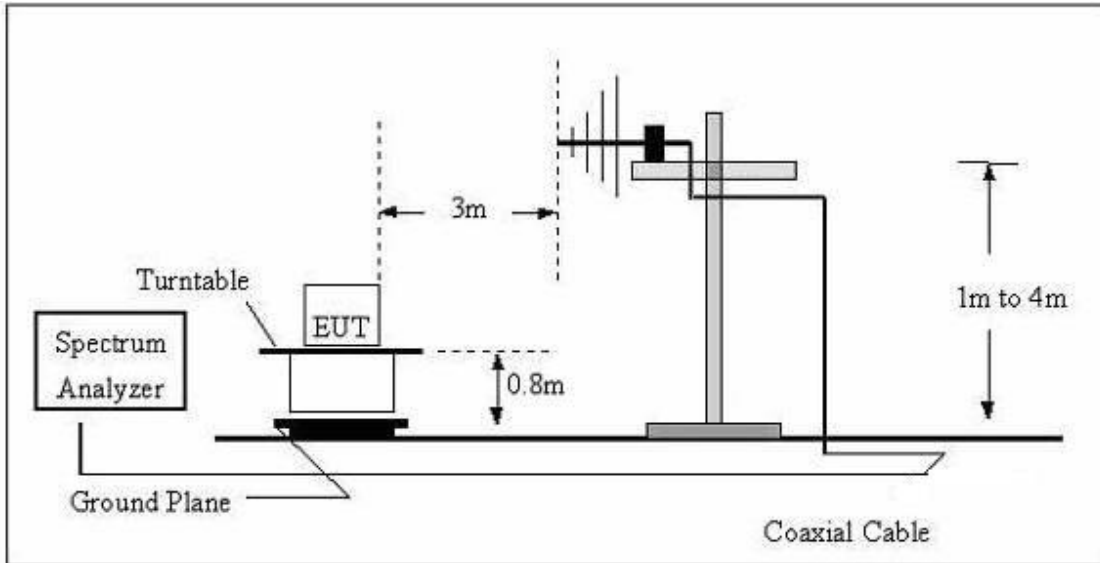

(C) Radiated Emission Test-Up Frequency Above 1GHz

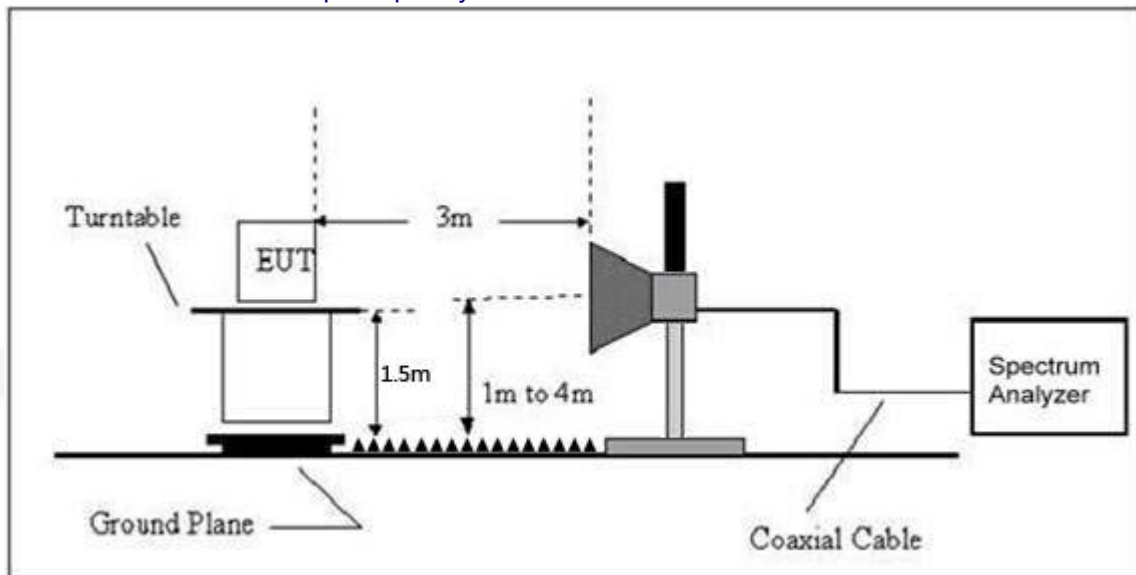

4.2.5 EUT OPERATING CONDITIONS

The EUT tested system was configured as the statements of 2.4 Unless otherwise a special operating condition is specified in the follows during the testing.

4.2.6 TEST RESULTS (Between 9KHz – 30 MHz)

The emission from 9 kHz to 30MHz was pre-tested and found the result was 20dB lower than the limit, and according to 15.31(o) & RSS-Gen 6.13, the test result no need to reported.



Between 30MHz – 1GHz

Temperature:	25°C	Relative Humidity:	60%
Test Voltage:	AC 120V, 60Hz	Phase:	Horizontal
Test Mode:	Transmitting mode of 8DPSK 2402MHz		

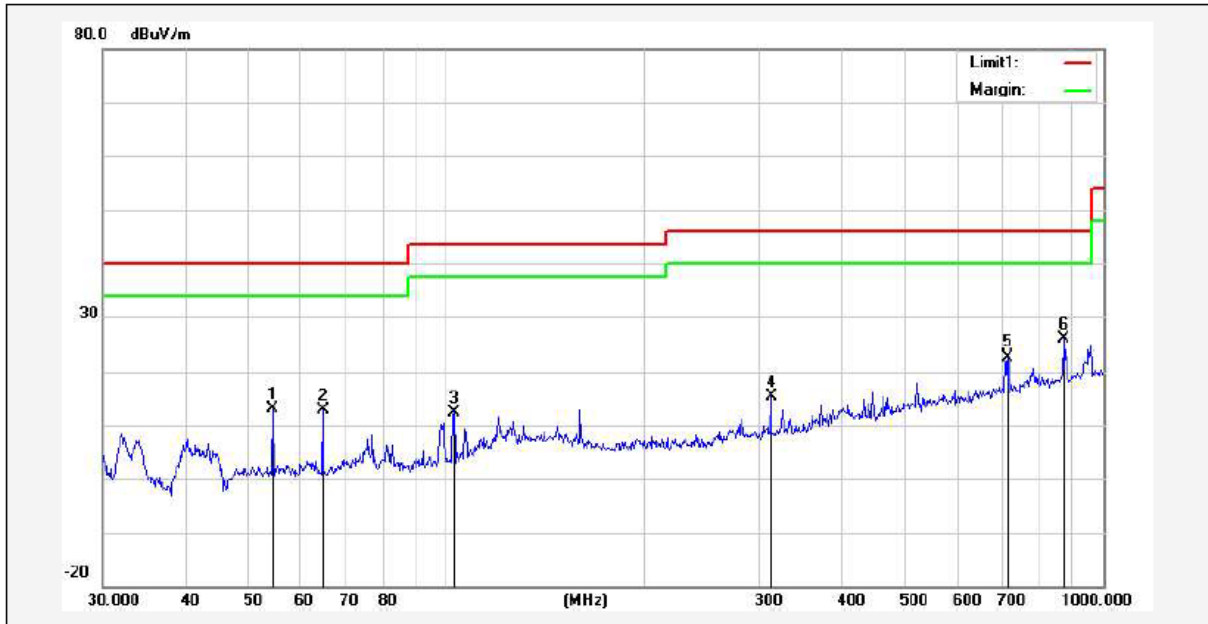

No.	Frequency (MHz)	Reading (dBuV)	Correction factor(dB/m)	Result (dBuV/m)	Limit (dBuV/m)	Margin (dB)	Degree (deg.)	Height (cm)	Remark
1	54.4516	40.35	-27.31	13.04	40.00	-26.96			QP
2	64.8865	39.57	-26.66	12.91	40.00	-27.09			QP
3	102.7192	36.72	-24.23	12.49	43.50	-31.01			QP
4	312.1794	34.84	-19.49	15.35	46.00	-30.65			QP
5	716.6820	36.24	-13.57	22.67	46.00	-23.33			QP
6*	869.1302	36.89	-10.99	25.90	46.00	-20.10			QP



Temperature:	25°C	Relative Humidity:	60%
Test Voltage:	AC 120V, 60Hz	Phase:	Vertical
Test Mode:	Transmitting mode of 8DPSK 2402MHz		

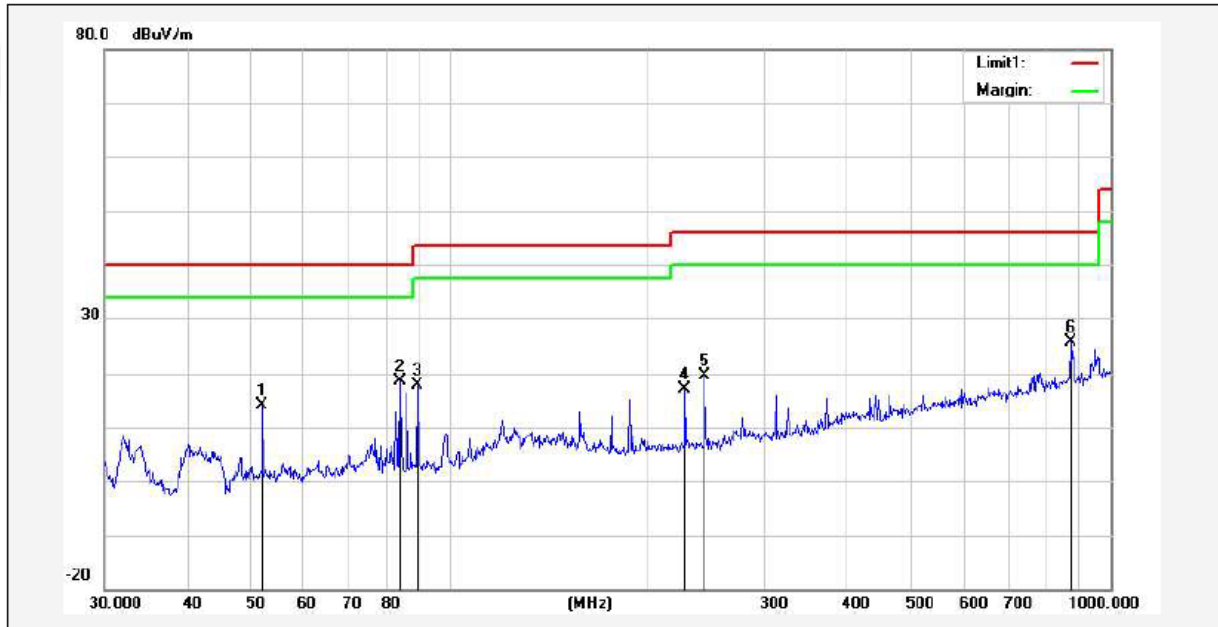

No.	Frequency (MHz)	Reading (dBuV)	Correction factor(dB/m)	Result (dBuV/m)	Limit (dBuV/m)	Margin (dB)	Degree (deg.)	Height (cm)	Remark
1	52.0251	41.56	-27.38	14.18	40.00	-25.82			QP
2	84.1100	44.57	-25.87	18.70	40.00	-21.30			QP
3	89.2764	43.59	-25.72	17.87	43.50	-25.63			QP
4	226.8936	38.61	-21.52	17.09	46.00	-28.91			QP
5	243.3772	40.88	-21.20	19.68	46.00	-26.32			QP
6*	869.1302	36.74	-10.99	25.75	46.00	-20.25			QP

Remarks:

- 1.Final Level =Receiver Read level + Antenna Factor + Cable Loss – Preamplifier Factor
- 2.The emission levels of other frequencies are very lower than the limit and not show in test report.



## GFSK 1GHz~25GHz

Polar (H/V)	Frequency	Meter Reading	Pre-ampli fier	Cable Loss	Antenna Factor	Emission Level	Limits	Margin	Detector Type
	(MHz)	(dBuV)	(dB)	(dB)	(dB)	(dBuV/m)	(dBuV/m)	(dB)	
Low Channel:2402MHz									
V	4804.00	54.98	30.55	5.77	24.66	54.86	74.00	-19.14	Pk
V	4804.00	43.21	30.55	5.77	24.66	43.09	54.00	-10.91	AV
V	7206.00	54.10	30.33	6.32	24.55	54.64	74.00	-19.36	Pk
V	7206.00	43.71	30.33	6.32	24.55	44.25	54.00	-9.75	AV
V	9608.00	52.70	30.85	7.45	24.69	53.99	74.00	-20.01	Pk
V	9608.00	43.42	30.85	7.45	24.69	44.71	54.00	-9.29	AV
V	12010.00	52.60	31.02	8.99	25.57	56.14	74.00	-17.86	Pk
V	12010.00	43.28	31.02	8.99	25.57	46.82	54.00	-7.18	AV
H	4804.00	51.37	30.55	5.77	24.66	51.25	74.00	-22.75	Pk
H	4804.00	43.03	30.55	5.77	24.66	42.91	54.00	-11.09	AV
H	7206.00	54.51	30.33	6.32	24.55	55.05	74.00	-18.95	Pk
H	7206.00	43.14	30.33	6.32	24.55	43.68	54.00	-10.32	AV
H	9608.00	52.84	30.85	7.45	24.69	54.13	74.00	-19.87	Pk
H	9608.00	43.98	30.85	7.45	24.69	45.27	54.00	-8.73	AV
H	12010.00	54.90	31.02	8.99	25.57	58.44	74.00	-15.56	Pk
H	12010.00	43.85	31.02	8.99	25.57	47.39	54.00	-6.61	AV

Polar (H/V)	Frequency	Meter Reading	Pre-ampli fier	Cable Loss	Antenna Factor	Emission Level	Limits	Margin	Detector Type
	(MHz)	(dBuV)	(dB)	(dB)	(dB)	(dBuV/m)	(dBuV/m)	(dB)	
Middle Channel:2441MHz									
V	4882.00	50.09	30.55	5.77	24.66	49.97	74.00	-24.03	Pk
V	4882.00	43.34	30.55	5.77	24.66	43.22	54.00	-10.78	AV
V	7323.00	50.70	30.33	6.32	24.55	51.24	74.00	-22.76	Pk
V	7323.00	43.57	30.33	6.32	24.55	44.11	54.00	-9.89	AV
V	9764.00	54.23	30.85	7.45	24.69	55.52	74.00	-18.48	Pk
V	9764.00	43.82	30.85	7.45	24.69	45.11	54.00	-8.89	AV
V	12205.00	54.42	31.02	8.99	25.57	57.96	74.00	-16.04	Pk
V	12205.00	43.12	31.02	8.99	25.57	46.66	54.00	-7.34	AV
H	4882.00	51.53	30.55	5.77	24.66	51.41	74.00	-22.59	Pk
H	4882.00	43.99	30.55	5.77	24.66	43.87	54.00	-10.13	AV
H	7323.00	50.35	30.33	6.32	24.55	50.89	74.00	-23.11	Pk
H	7323.00	43.97	30.33	6.32	24.55	44.51	54.00	-9.49	AV
H	9764.00	53.07	30.85	7.45	24.69	54.36	74.00	-19.64	Pk
H	9764.00	43.16	30.85	7.45	24.69	44.45	54.00	-9.55	AV
H	12205.00	53.38	31.02	8.99	25.57	56.92	74.00	-17.08	Pk
H	12205.00	43.78	31.02	8.99	25.57	47.32	54.00	-6.68	AV



Polar (H/V)	Frequency	Meter Reading	Pre-ampli fier	Cable Loss	Antenna Factor	Emission Level	Limits	Margin	Detector Type
	(MHz)	(dBuV)	(dB)	(dB)	(dB)	(dBuV/m)	(dBuV/m)	(dB)	
High Channel:2480MHz									
V	4960.00	50.97	30.55	5.77	24.66	50.85	74.00	-23.15	Pk
V	4960.00	43.45	30.55	5.77	24.66	43.33	54.00	-10.67	AV
V	7440.00	54.81	30.33	6.32	24.55	55.35	74.00	-18.65	Pk
V	7440.00	43.51	30.33	6.32	24.55	44.05	54.00	-9.95	AV
V	9920.00	51.46	30.85	7.45	24.69	52.75	74.00	-21.25	Pk
V	9920.00	43.29	30.85	7.45	24.69	44.58	54.00	-9.42	AV
V	12400.00	53.08	31.02	8.99	25.57	56.62	74.00	-17.38	Pk
V	12400.00	43.63	31.02	8.99	25.57	47.17	54.00	-6.83	AV
H	4960.00	54.19	30.55	5.77	24.66	54.07	74.00	-19.93	Pk
H	4960.00	43.37	30.55	5.77	24.66	43.25	54.00	-10.75	AV
H	7440.00	51.33	30.33	6.32	24.55	51.87	74.00	-22.13	Pk
H	7440.00	43.56	30.33	6.32	24.55	44.10	54.00	-9.90	AV
H	9920.00	50.50	30.85	7.45	24.69	51.79	74.00	-22.21	Pk
H	9920.00	43.81	30.85	7.45	24.69	45.10	54.00	-8.90	AV
H	12400.00	52.98	31.02	8.99	25.57	56.52	74.00	-17.48	Pk
H	12400.00	43.71	31.02	8.99	25.57	47.25	54.00	-6.75	AV

## Remark:

1. Emission Level = Meter Reading + Antenna Factor + Cable Loss – Pre-amplifier,  
Margin= Emission Level - Limit
2. If peak below the average limit, the average emission was no test.
3. The amplitude of spurious emissions which are attenuated by more than 20dB below the permissible value has no need to be reported.



## 5. BANDWIDTH OF FREQUENCY BAND EDGE

### 5.1 Limit

Fundamental frequency	Field strength of fundamental@3m (millivolts/meter)	Average Limit@3m dB $\mu$ V/m	Peak Limit@3m dB $\mu$ V/m
902-928MHz	50	94	114
2407-2477MHz	50	94	114
5725-5875MHz	50	94	114
24.0-24.25	250	108	128

Note :

1. Average Limit (dB $\mu$ V/m)=20 $\times$ log[1000 $\times$ Field Strength (mV/m)].
2. Peak Limit (dB $\mu$ V/m)= Average Limit (dB $\mu$ V/m)+20dB

### 5.2 Test Setup

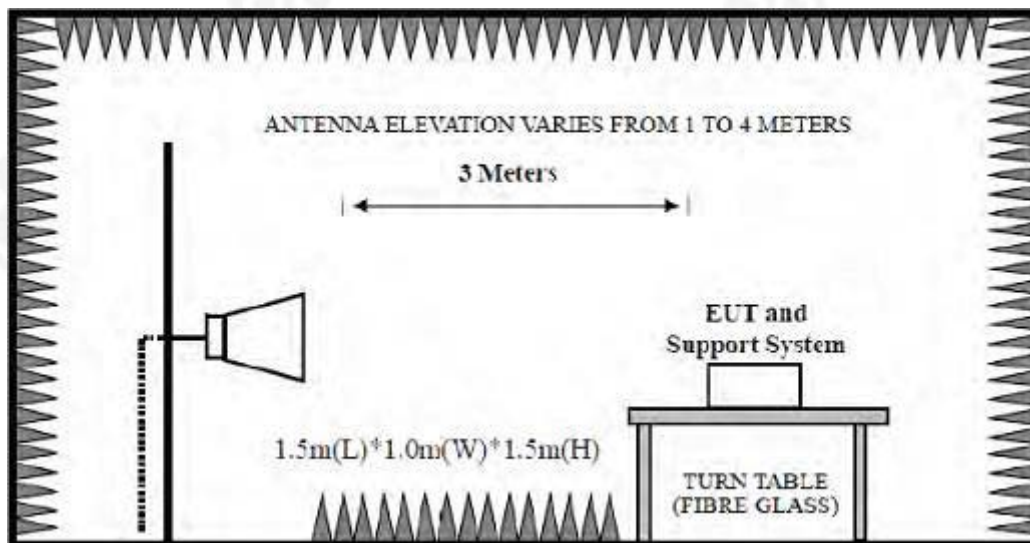

### 5.2 Spectrum Analyzer Setting

Spectrum Parameters	Setting
RBW	$\geq$ OBW
VBW	3 $\times$ RBW
Start frequency	2407MHz
Stop frequency	2477MHz
Sweep Time	Auto
Detector	PEAK/AVG
Trace Mode	Max Hold





#### 5.4 Test Procedure

- a. EUT was placed on a turn table, which is 1.5 meter high above the ground.
- b. EUT is set 3 meters away from the receiving antenna, which is mounted on a antenna tower.
- c. Spectrum analyzer setting parameters in accordance with section 3.3.
- d. Set the EUT transmit continuously with maximum output power.
- e. The turn table can rotate 360 degrees to determine the position of the maximum emission level.
- f. The antenna can be moved up and down between 1 meter and 4 meters to find out the maximum emission level. Both horizontal and vertical polarization of the antenna are set on test,record the average and peak value.
- g. Repeat above procedures until all channels were measured.
- h. Record the results in the test report.

#### 5.5 Test Result

Test frequency (MHz)	Fundamental Frequency (MHz)	Field strength of fundamental level (dB $\mu$ V/m)		Limit (dBuV)		Result	Antenna Pole (H/V)
		AVG	Peak	AVG	Peak		
2402	2402.930	89.86	93.35	94	114	Pass	H
	2402.934	89.36	94.30	94	114	Pass	V
2441	2441.731	91.77	92.26	94	114	Pass	H
	2441.524	92.23	92.75	94	114	Pass	V
2480	2481.736	91.88	93.24	94	114	Pass	H
	2480.159	92.15	93.01	94	114	Pass	V



## 6. BANDWIDTH OF FREQUENCY BAND EDGE

### 6.1 TEST REQUIREMENT:

Test Requirement:	FCC Part15 C Section 15.209 and 15.205				
Test Method:	ANSI C63.10: 2013				
Test Frequency Range:	All of the restrict bands were tested, only the worst band's (2310MHz to 2500MHz) data was showed.				
Test site:	Measurement Distance: 3m				
Receiver setup:	Frequency	Detector	RBW	VBW	Value
	Above 1GHz	Peak	1MHz	3MHz	Peak
		Average	1MHz	3MHz	Average

Emissions radiated outside of the specified frequency bands, except for harmonics, shall be attenuated by at least 50 dB below the level of the fundamental or to the general radiated emission limits in § 15.209, whichever is the lesser attenuation

### 6.2 TEST PROCEDURE

Above 1GHz test procedure as below:

- a. 1. The EUT was placed on the top of a rotating table 1.5 meters above the ground at a 3 meter camber. The table was rotated 360 degrees to determine the position of the highest radiation.
- b. The EUT was set 3 meters away from the interference-receiving antenna, which was mounted on the top of a variable-height antenna tower.
- c. The antenna height is varied from one meter to four meters above the ground to determine the maximum value of the field strength. Both horizontal and vertical polarizations of the antenna are set to make the measurement.
- d. For each suspected emission, the EUT was arranged to its worst case and then the antenna was tuned to heights from 1 meter to 4 meters and the rota table was turned from 0 degrees to 360 degrees to find the maximum reading.
- e. The test-receiver system was set to Peak Detect Function and Specified Bandwidth with Maximum Hold Mode.
- f. If the emission level of the EUT in peak mode was 10dB lower than the limit specified, then testing could be stopped and the peak values of the EUT would be reported. Otherwise the emissions that did not have 10dB margin would be re-tested one by one using peak, quasi-peak or average method as specified and then reported in a data sheet.
- g. Test the EUT in the lowest channel, the Highest channel

Note:

Both horizontal and vertical antenna polarities were tested and performed pretest to three orthogonal axis. The worst case emissions were reported

### 6.3 DEVIATION FROM TEST STANDARD

No deviation

### 6.4 TEST SETUP



### Radiated Emission Test-Up Frequency Above 1GHz

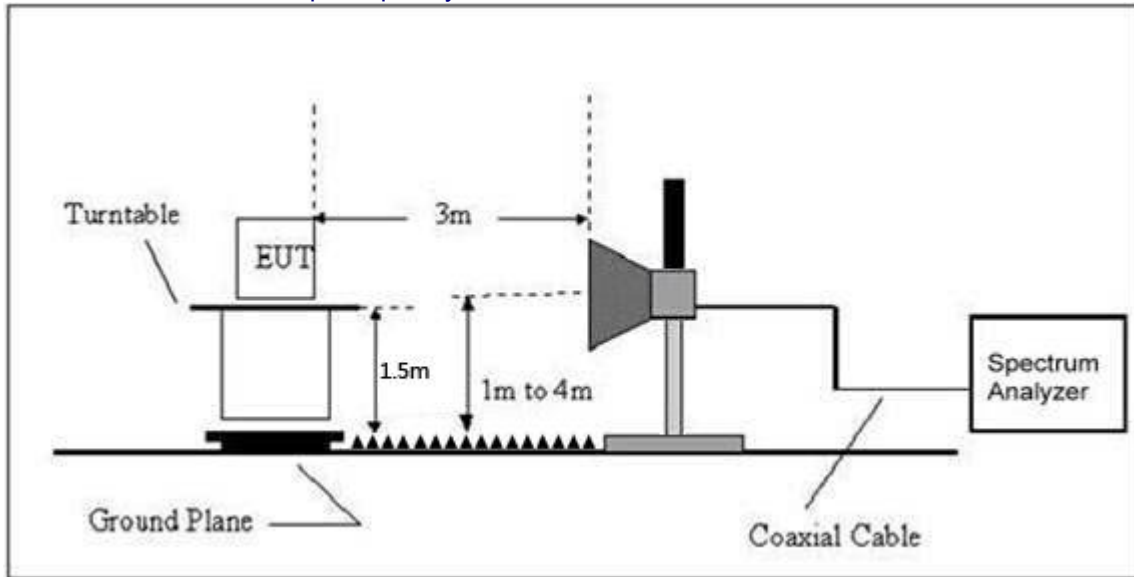

#### 6.5 EUT OPERATING CONDITIONS

The EUT tested system was configured as the statements of 2.3 Unless otherwise a special operating condition is specified in the follows during the testing.



### 6.6 TEST RESULT

Operation Mode: TX CH00 (2402MHz)

Horizontal:

Frequency (MHz)	Reading Result (dB $\mu$ V)	Factor (dB)	Emission Level (dB $\mu$ V/m)	Limits (dB $\mu$ V/m)	Margin (dB)	Detector Type
2310	57.58	-5.81	51.77	74	-22.23	PK
2310	/	-5.81	/	54	/	AV
2390	57.15	-5.84	51.31	74	-22.69	PK
2390	/	-5.84	/	54	/	AV
2400	57.21	-5.84	51.37	74	-22.63	PK
2400	/	-5.84	/	54	/	AV

Remark: Factor = Antenna Factor + Cable Loss – Pre-amplifier.

Vertical:

Frequency (MHz)	Reading Result (dB $\mu$ V)	Factor (dB)	Emission Level (dB $\mu$ V/m)	Limits (dB $\mu$ V/m)	Margin (dB)	Detector Type
2310	56.58	-5.81	50.77	74	-23.23	PK
2310	/	-5.81	/	54	/	AV
2390	56.35	-5.84	50.51	74	-23.49	PK
2390	/	-5.84	/	54	/	AV
2400	57.24	-5.84	51.4	74	-22.6	PK
2400	/	-5.84	/	54	/	AV

Remark: Factor = Antenna Factor + Cable Loss – Pre-amplifier.



Operation Mode: TX CH39 (2480MHz)

Horizontal:

Frequency (MHz)	Reading Result (dB $\mu$ V)	Factor (dB)	Emission Level (dB $\mu$ V/m)	Limits (dB $\mu$ V/m)	Margin (dB)	Detector Type
2483.5	55.75	-5.65	50.1	74	-23.9	PK
2483.5	/	-5.65	/	54	/	AV
2500	56.84	-5.72	51.12	74	-22.88	PK
2500	/	-5.72	/	54	/	AV

Remark: Factor = Antenna Factor + Cable Loss - Pre-amplifier.

Vertical:

Frequency (MHz)	Reading Result (dB $\mu$ V)	Factor (dB)	Emission Level (dB $\mu$ V/m)	Limits (dB $\mu$ V/m)	Margin (dB)	Detector Type
2483.5	57.37	-5.65	51.72	74	-22.28	PK
2483.5	/	-5.65	/	54	/	AV
2500	56.85	-5.72	51.13	74	-22.87	PK
2500	/	-5.72	/	54	/	AV

Remark: Factor = Antenna Factor + Cable Loss - Pre-amplifier.



## 7. CHANNEL BANDWIDTH

Test Requirement:	FCC Part15 C Section 15.249/15.215
Test Method:	ANSI C63.10: 2013

### 7.1 APPLIED PROCEDURES / LIMIT

FCC Part15 (15.249) , Subpart C			
Section	Test Item	Frequency Range (MHz)	Result
15.249(c)	Bandwidth	2400-2483.5	PASS

### 7.2 TEST PROCEDURE

1. Set resolution bandwidth (RBW) = 1-5% or DTS BW, not to exceed 100 kHz.
2. Set the video bandwidth (VBW)  $\geq 3 \times$  RBW.
3. Detector = Peak.
4. Trace mode = max hold.
5. Sweep = auto couple.
6. Allow the trace to stabilize.
7. Measure the maximum width of the emission that is constrained by the frequencies associated with the two outermost amplitude points (upper and lower) that are attenuated by 6 dB relative to the maximum level measured in the fundamental emission.

### 7.3 DEVIATION FROM STANDARD

No deviation.

### 7.4 TEST SETUP

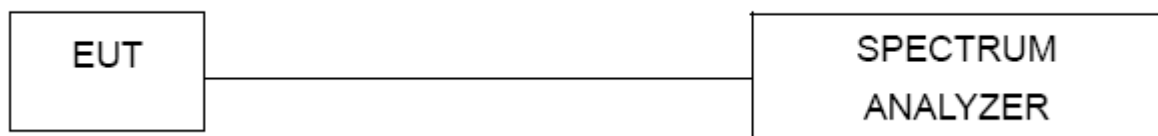

### 7.5 EUT OPERATION CONDITIONS

The EUT tested system was configured as the statements of 2.4 Unless otherwise a special operating condition is specified in the follows during the testing.



7.6 TEST RESULT

GFSK Modulation:

Channel	Frequency (MHz)	20dB Bandwidth (MHz)	Result
CH00	2402	0.943	PASS
CH39	2441	0.931	PASS
CH78	2480	0.864	PASS

CH00: 2402MHz

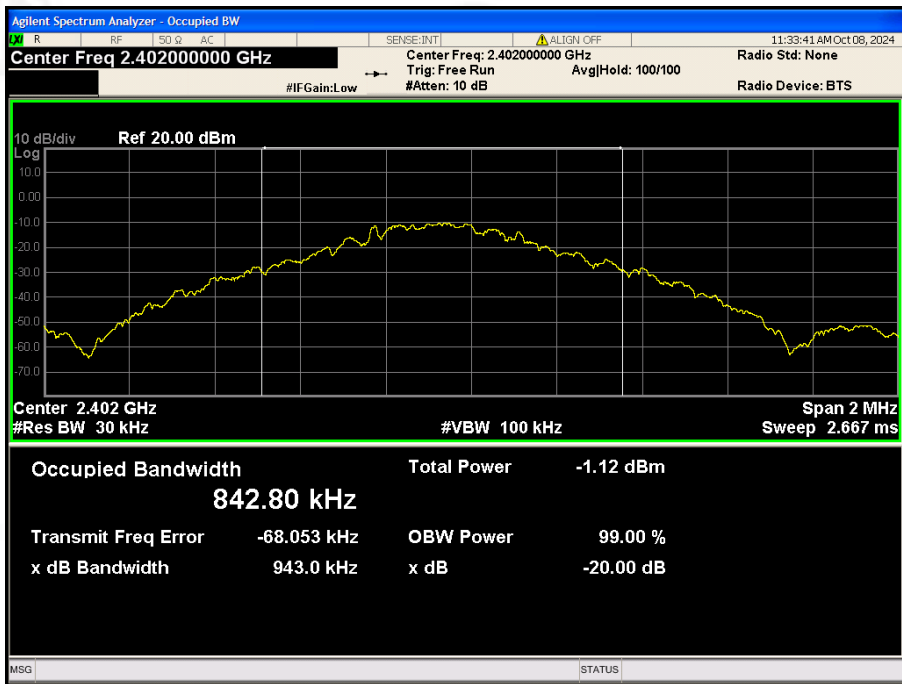



CH39: 2441MHz

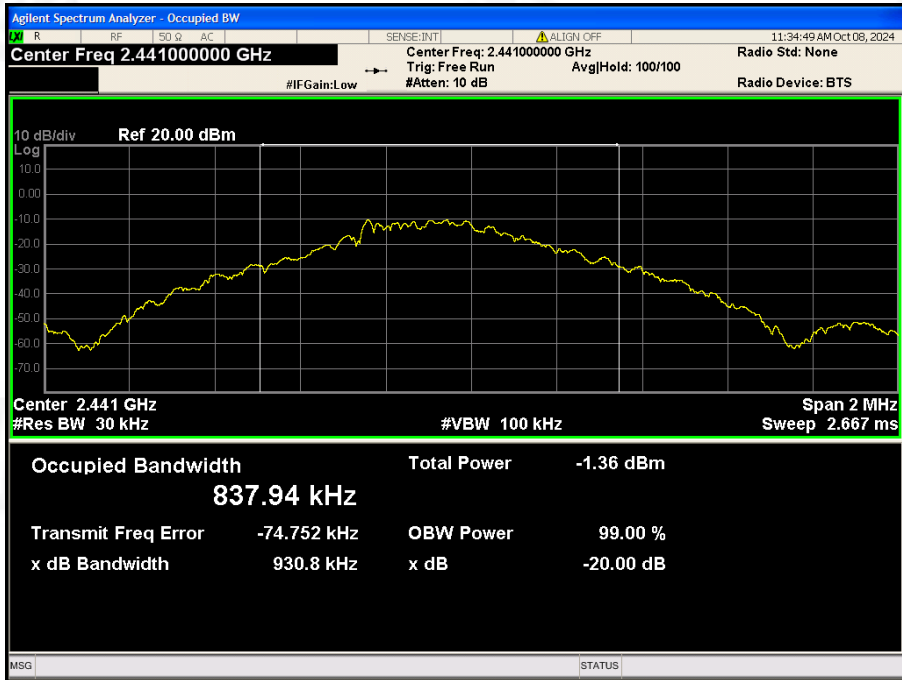

CH78: 2480MHz

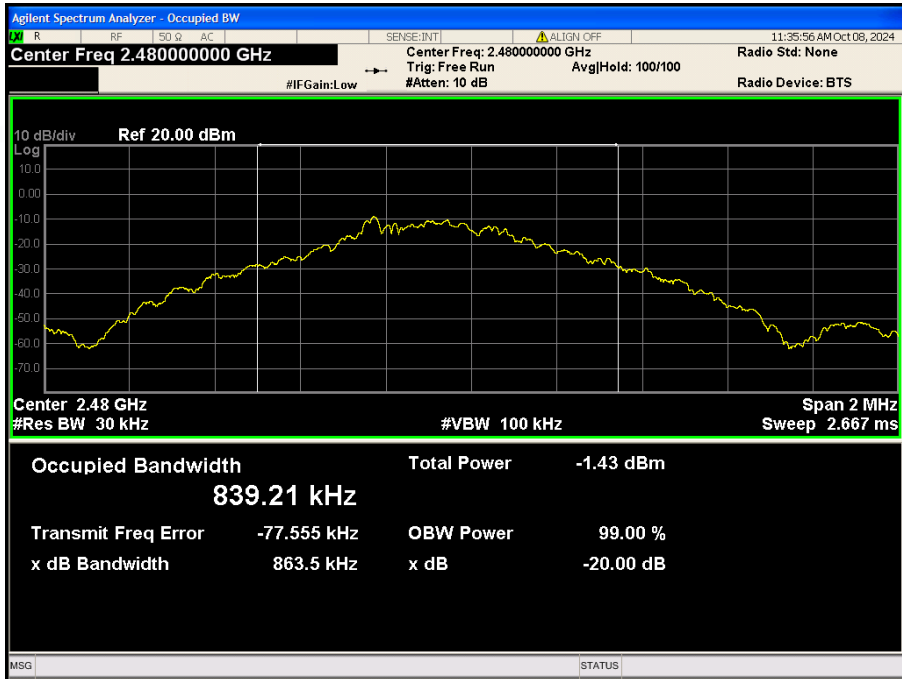





$\pi$  /4 DQPSK Modulation:

Channel	Frequency (MHz)	20dB Bandwidth (MHz)	Result
CH00	2402	1.281	PASS
CH39	2441	1.281	PASS
CH78	2480	1.280	PASS

CH00: 2402MHz

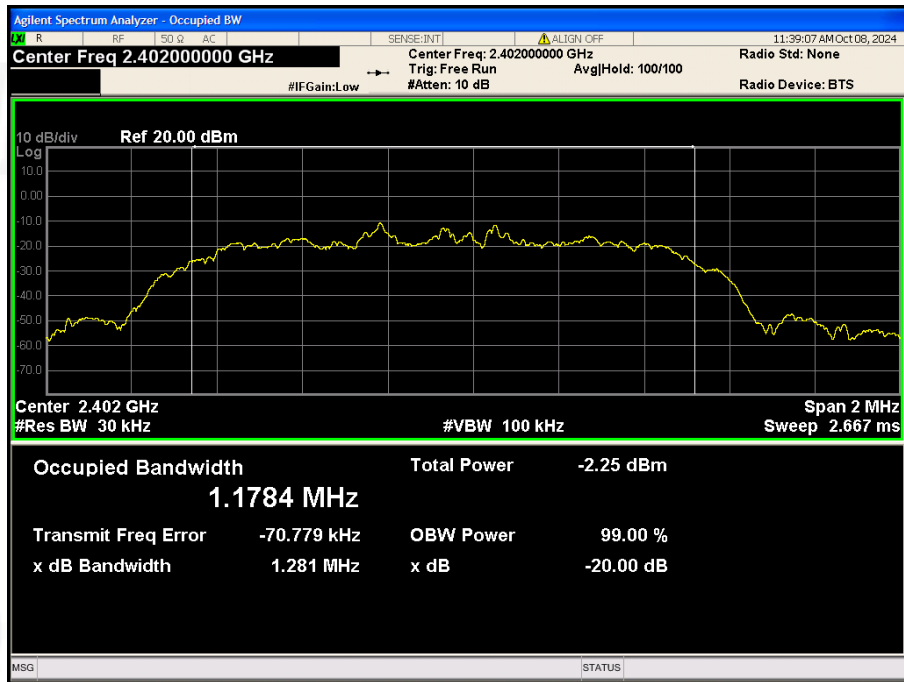



CH39: 2441MHz

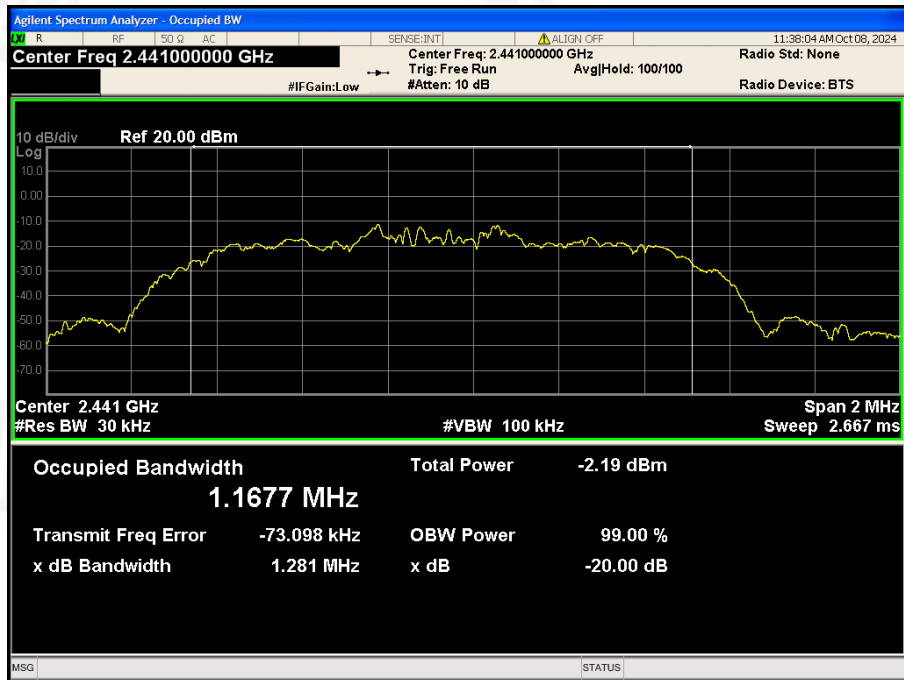

CH78: 2480MHz

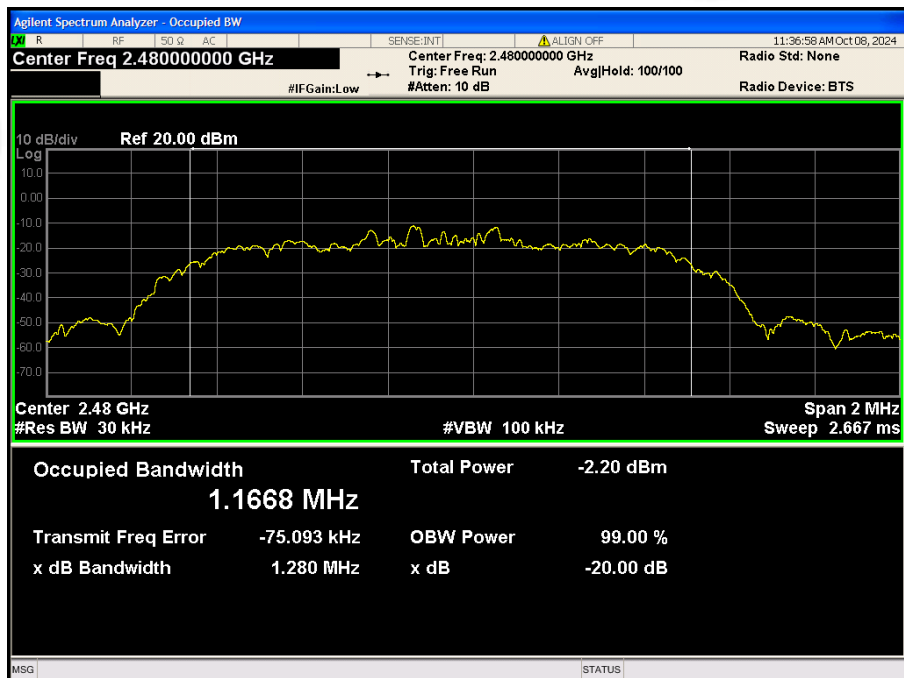



8DPSK Modulation:

Channel	Frequency (MHz)	20dB Bandwidth (MHz)	Result
CH00	2402	1.249	PASS
CH39	2441	1.298	PASS
CH78	2480	1.253	PASS

CH00: 2402MHz

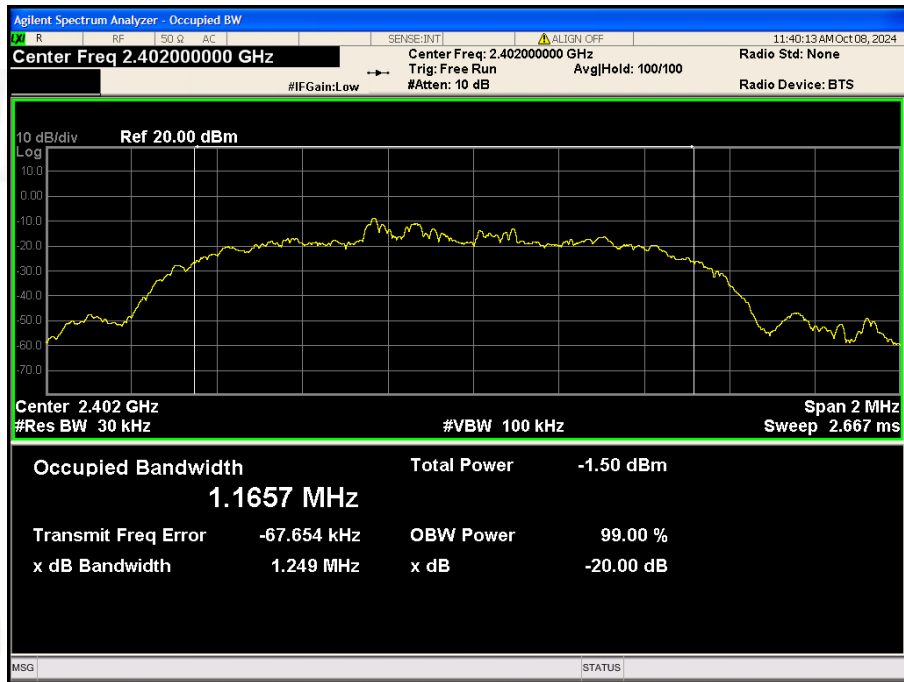



CH39: 2441MHz

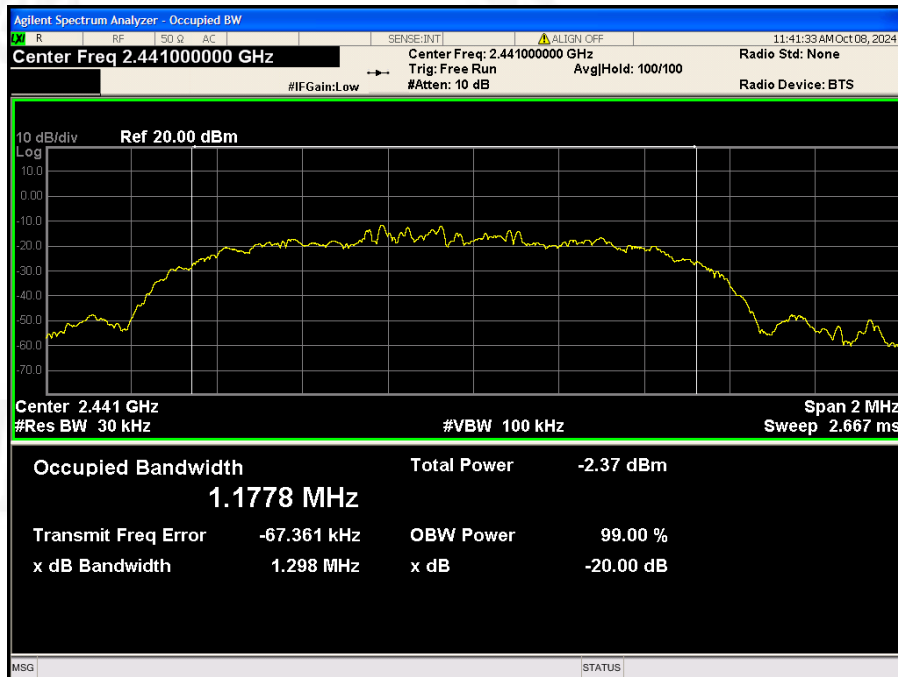

CH78: 2480MHz

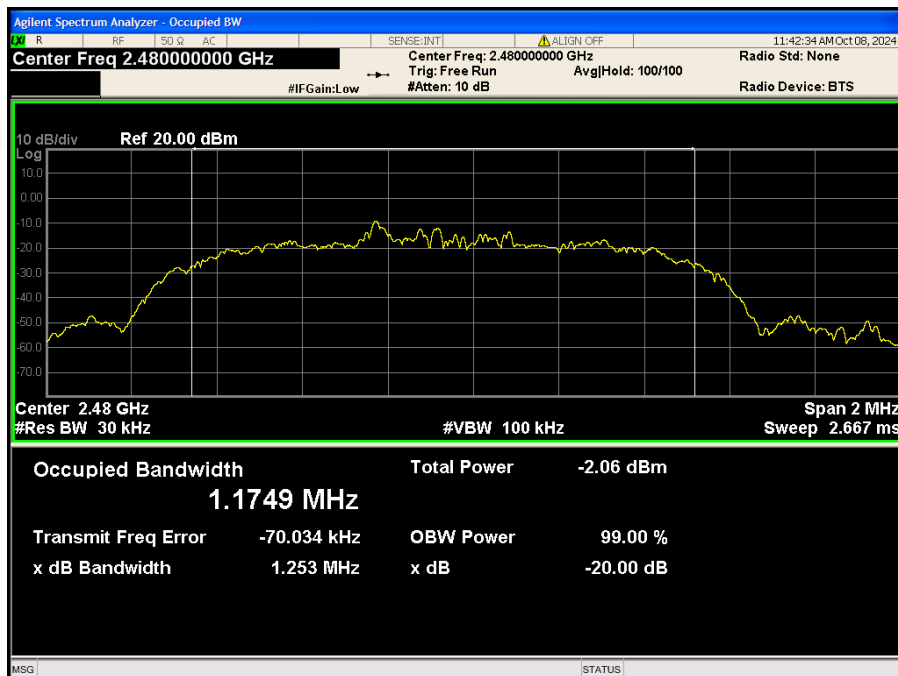



## 8.ANTENNA REQUIREMENT

Standard requirement:	FCC Part15 C Section 15.203
15.203 requirement: An intentional radiator shall be designed to ensure that no antenna other than that furnished by the responsible party shall be used with the device. The use of a permanently attached antenna or of an antenna that uses a unique coupling to the intentional radiator, the manufacturer may design the unit so that a broken antenna can be replaced by the user, but the use of a standard antenna jack or electrical connector is prohibited.	
EUT Antenna:	
The antennas are PCB antenna, the best case gain of the antennas are 2.09dBi, reference to the appendix II for details.	



**9. TEST SETUP PHOTO**

Reference to the appendix I for details.

**10. EUT CONSTRUCTIONAL DETAILS**

Reference to the appendix II for details.

**\*\*\*\*\* END OF REPORT \*\*\*\*\***