

# 深圳市三盛创电子科技有限公司

## 承 認 書

客 戶:  
CUSTOMER: 深圳瀚彩科技有限公司

客 戶 料 號:  
CUST P/N:

三盛创 料 號:  
FINE P/N: A11 线圈 6.3uH /0.07\*100P\*10TS

產 品 型 號:  
DESC:  $\Phi$  43.5MMX5.3MMX0.8MM 直槽

日 期:  
DATE: 2023.06.27

版 本:  
Version: A.0

擬制 PREPARED BY	審核 CHECKED BY	批准 APPROVED BY	客戶承認 CUSTOMER APPROVE
苏文静	安帅印	安帅印	

# 深圳市三盛创电子科技有限公司

工廠地址: 深圳市光明区玉塘街道玉律社区大洋一路 19 号 B 栋 201



# SPECIFICATION

產品型號: DESC	$\Phi 20.5\text{MMX}43.5\text{-}6.3\mu\text{H}\text{-}0.07\text{*}100\text{P}\text{*}10\text{TS}$	版本 Rev: A.0	客戶 CUST: 客戶料号 CUST P/N:
---------------	---	----------------	----------------------------

## 一、尺寸 DIMENSION:(mm)

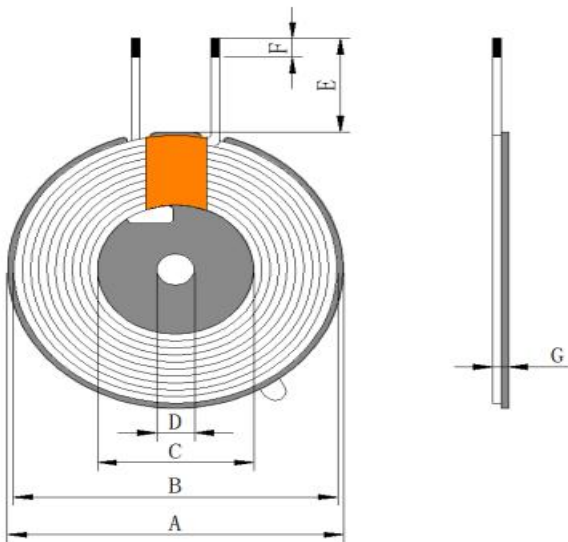

A	$43.5 \pm 0.5$
B	$42 \pm 1.0$
C	$20.5 \pm 0.5$
D	$5.3 \pm 0.5$
E	$30 \pm 1.5$
F	$3 \pm 1$
G	$2.2 \pm 0.2$

## 二、原理图 SCHEMATIC DIAGRAM:

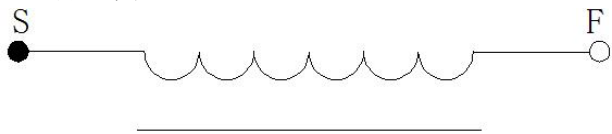

### 注:

- Cross outgoing line;
- Wrap 8mm (ref) wide high-temperature adhesive tape 1-2Ts around the outlet position;
- The coil is attached with a circular hard magnetic disc with slots, with a magnetic disc size of  $43.5 \pm 0.5\text{mm}$ , an inner hole of  $5.3 \pm 0.5\text{mm}$ , and a thickness of  $0.8 \pm 0.1\text{mm}$ .
- Stick Double-sided tape on the back of the coil

## 三、绕线参数 Winding Specification:

序号 NO.	端子 TERMINAL		线径 WIRE	圈数 Turns	绕线方向 Winding Direction
1	S	F	丝包线 0.07*100P	10Ts	CCW

## 四、电气特性 ELECTRICAL CHARACTERISTICS:

温度 TEMPERATURE: $25 \pm 10^\circ\text{C}$ , 湿度 RELATIVE HUMIDITY: $65 \pm 20\%$

序号 NO.	项目 ITEM	端子 TERMINAL	标准 SPECIFICATION	测试条件 TEST FREQUENCY	测试仪器 TEST EQUIPMENTS
1	IND.	S-F	$3.8\mu\text{H} \pm 10\%$ 单独线圈	100KHz/1.0V	LCZ METER 1062B
2	IND.	S-F	$6.3\mu\text{H} \pm 10\%$ 加磁片	100KHz/1.0V	LCZ METER 1062B
3	DCR	S-F	$\leq 50\text{m}\Omega$	100KHz/1.0V	LCZ METER 502B
4	Q	S-F	$\geq 68$	100KHz/1.0V	LCZ METER 502B

擬制/日期 PREPARED BY/DATE

審核/日期 CHECKED BY/DATE

苏文静 2023.06.27

安帅印 2023.06.27