

FCC TEST REPORT

FCC ID:2BAXO-P9

Report Number..... : ZKT-230420L2861E

Date of Test..... Apr. 14, 2023 to Apr. 27, 2023

Date of issue..... : Apr. 27, 2023

Total number of pages..... 36

Test Result : PASS

Testing Laboratory..... : Shenzhen ZKT Technology Co., Ltd.

Address : 1/F, No. 101, Building B, No. 6, Tangwei Community Industrial Avenue, Fuhai Street, Bao'an District, Shenzhen, China

Applicant's name : DONGGUAN POWERFULL TECHNOLOGY CO., LTD.

Address : 3F, Building 2, No.3 XinJi Road, Machong Town, Dongguan, Guangdong, China

Manufacturer's name : DONGGUAN POWERFULL TECHNOLOGY CO., LTD.

Address : 3F, Building 2, No.3 XinJi Road, Machong Town, Dongguan, Guangdong, China

Test specification:

Standard..... : FCC CFR Title 47 Part 15 Subpart C Section 15.236
ANSI C63.10:2013

Test procedure..... : /

Non-standard test method : N/A

Test Report Form No..... : TRF-EL-108_V0

Test Report Form(s) Originator..... : ZKT Testing

Master TRF : Dated: 2020-01-06

This device described above has been tested by ZKT, and the test results show that the equipment under test (EUT) is in compliance with the FCC requirements. And it is applicable only to the tested sample identified in the report.

This report shall not be reproduced except in full, without the written approval of ZKT, this document may be altered or revised by ZKT, personal only, and shall be noted in the revision of the document.

Product name..... : Portable Wireless Microphone

Trademark : N/A

Model/Type reference..... : P9, P1, P2, P3, P4, P5, P6, P7, P8, P10, P11, P12, P13, P14, P15, P16, P17, P18,P19, P20

Ratings..... : DC 3V from AA Battery

Testing procedure and testing location:

Testing Laboratory.....: **Shenzhen ZKT Technology Co., Ltd.**

Address.....: 1/F, No. 101, Building B, No. 6, Tangwei Community Industrial Avenue, Fuhai Street, Bao'an District, Shenzhen, China

Tested by (name + signature).....: Alen He

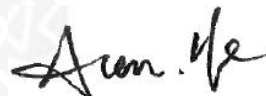

Reviewer (name + signature).....: Joe Liu



Approved (name + signature).....: Lake Xie



Table of Contents	Page
1. VERSION	5
2. SUMMARY OF TEST RESULTS	6
2.1 TEST FACILITY	7
2.2 MEASUREMENT UNCERTAINTY	7
3. GENERAL INFORMATION	8
3.1 GENERAL DESCRIPTION OF EUT	8
3.2 DESCRIPTION OF TEST MODES	9
3.3 BLOCK DIAGRAM SHOWING THE CONFIGURATION OF SYSTEM TESTED	9
3.4 DESCRIPTION OF SUPPORT UNITS(CONDUCTED MODE)	9
3.5 EQUIPMENTS LIST FOR ALL TEST ITEMS	10
4. EMC EMISSION TEST	12
4.1 CONDUCTED EMISSION MEASUREMENT	12
4.1.1 POWER LINE CONDUCTED EMISSION LIMITS	12
4.1.2 TEST PROCEDURE	13
4.1.3 DEVIATION FROM TEST STANDARD	13
4.1.4 TEST SETUP	13
4.1.5 EUT OPERATING CONDITIONS	13
4.1.6 TEST RESULTS	13
4.2 RADIATED EMISSION LIMITS	14
4.2.3 TEST SETUP	15
4.2.4 TEST PROCEDURE	16
4.2.5 TEST RESULTS	16
5. CONDUCTED OUTPUT POWER	21
5.1 APPLIED PROCEDURES / LIMIT	21
5.2 TEST PROCEDURE	21
5.3 DEVIATION FROM STANDARD	21
5.4 TEST SETUP	21
5.5 EUT OPERATION CONDITIONS	21
5.6 TEST RESULTS	22
6. CHANNEL BANDWIDTH	24
7. NECESSARY BANDWIDTH	27
7.1 LIMIT	27
7.2 TEST SETUP	27
7.3 TEST PROCEDURE	28
7.4 TEST RESULTS	28
8. FREQUENCY STABILITY	31

Table of Contents

Page

9. ANTENNA REQUIREMENT	35
9. TEST SETUP PHOTO	36
10. EUT CONSTRUCTIONAL DETAILS	36

1. VERSION

Report No.	Version	Description	Approved
ZKT-230420L2861E	Rev.01	Initial issue of report	Apr. 27, 2023

2. SUMMARY OF TEST RESULTS

Test procedures according to the technical standards:

FCC Part15 (15.236) , Subpart C			
Standard Section	Test Item	Judgment	Remark
15.203	Antenna Requirement	PASS	
15.207	Conducted Emission	N/A	
15.236(d)(1)	Maximum Radiated Power(EIRP)	PASS	
15.236(g)	Radiated Spurious Emission Measurement	PASS	
15.236(g)	Spurious Emission at Antenna Port	PASS	
15.236(f)(2)	Occupied Bandwidth Emission	PASS	
15.236(f)(3)	Frequency Stability	PASS	

NOTE:

(1) "N/A" denotes test is not applicable in this Test Report

2.1 TEST FACILITY

Shenzhen ZKT Technology Co., Ltd.
Add. : 1/F, No. 101, Building B, No. 6, Tangwei Community Industrial Avenue, Fuhai Street, Bao'an District, Shenzhen, China

FCC Test Firm Registration Number: 692225
Designation Number: CN1299
IC Registered No.: 27033

2.2 MEASUREMENT UNCERTAINTY

The reported uncertainty of measurement $y \pm U$ · where expanded uncertainty U is based on a standard uncertainty multiplied by a coverage factor of $k=2$ · providing a level of confidence of approximately 95 % ·

No.	Item	Uncertainty
1	AC Conduced Emission Test	$\pm 1.38\text{dB}$
2	3m camber Radiated spurious emission(9KHz-30MHz)	$U=4.5\text{dB}$
3	3m camber Radiated spurious emission(30MHz-1GHz)	$U=4.8\text{dB}$
4	3m chamber Radiated spurious emission(1GHz-18GHz)	$U=4.9\text{dB}$
5	3m chamber Radiated spurious emission(18GHz-40GHz)	$U=5.0\text{dB}$
6	Conducted Adjacent channel power	$U=1.38\text{dB}$
7	Conducted output power uncertainty Above 1G	$U=1.576\text{dB}$
8	Conducted output power uncertainty below 1G	$U=1.28\text{dB}$
9	humidity uncertainty	$U=5.3\%$
10	Temperature uncertainty	$U=0.59^{\circ}\text{C}$

3.GENERAL INFORMATION

3.1 GENERAL DESCRIPTION OF EUT

Equipment	Portable Wireless Microphone
Trade Name	N/A
Model Name	P9
Serial Model	P1, P2, P3, P4, P5, P6, P7, P8, P10, P11, P12, P13, P14, P15, P16, P17, P18,P19, P20
Model Difference	All the same except the model number
Hardware version	V1.0
Software version	V1.0
Operation Frequency:	550-554.48MHz
Modulation Type:	FSK
Antenna Type:	Internal Antenna
Antenna Gain:	1.21 dBi
Ratings	DC 3V from battery

Operation Frequency each of channel			
Channel	Frequency (MHz)	Channel	Frequency (MHz)
1	550	6	552.48
2	550.48	7	553
3	551	8	553.48
4	551.48	9	554
5	552	10	554.48

3.2 DESCRIPTION OF TEST MODES

For All Emission	
Final Test Mode	Description
Transmitting mode	Keep the EUT in continuously transmitting mode

Note:

- (1) Fully-charged battery is used during the test

3.3 BLOCK DIGRAM SHOWING THE CONFIGURATION OF SYSTEM TESTED

Conducted Emission Test

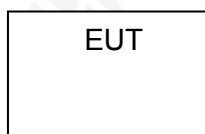

Spurious emissions

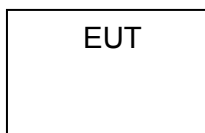

3.4 DESCRIPTION OF SUPPORT UNITS(CONDUCTED MODE)

The EUT has been tested as an independent unit together with other necessary accessories or support units. The following support units or accessories were used to form a representative test configuration during the tests.

Item	Equipment	Mfr/Brand	Model/Type No.	Series No.	Note
E-1	Portable Wireless Microphone	N/A	P9	N/A	EUT

Item	Shielded Type	Ferrite Core	Length	Note

Note:

- (1) The support equipment was authorized by Declaration of Confirmation.
- (2) For detachable type I/O cable should be specified the length in cm in 『Length』 column.
- (3) “YES” is means “shielded” “with core”; “NO” is means “unshielded” “without core”.

3.5 EQUIPMENTS LIST FOR ALL TEST ITEMS
Radiation Test equipment

Item	Equipment	Manufacturer	Type No.	Serial No.	Last calibration	Calibrated until
1	Spectrum Analyzer (9kHz-26.5GHz)	KEYSIGHT	9020A	MY55370835	Oct. 28, 2022	Oct. 27, 2023
2	Spectrum Analyzer (10kHz-39.9GHz)	R&S	FSQ	100363	Oct. 28, 2022	Oct. 27, 2023
3	EMI Test Receiver (9kHz-7GHz)	R&S	ESCI7	101169	Oct. 28, 2022	Oct. 27, 2023
4	Bilog Antenna (30MHz-1500MHz)	Schwarzbeck	VULB9168	N/A	Nov. 02, 2022	Nov. 01, 2023
5	Horn Antenna (1GHz-18GHz)	Agilent	AH-118	071145	Nov. 01, 2022	Oct. 31, 2023
6	Horn Antenna (15GHz-40GHz)	A.H.System	SAS-574	588	Oct. 28, 2022	Oct. 27, 2023
7	Loop Antenna	TESEQ	HLA6121	58357	Nov. 01, 2022	Oct. 31, 2023
8	Amplifier (30-1000MHz)	EM Electronics	EM330 Amplifier	060747	Nov. 15, 2022	Nov. 14, 2023
9	Amplifier (1GHz-26.5GHz)	Agilent	8449B	3008A00315	Oct. 28, 2022	Oct. 27, 2023
10	Amplifier (500MHz-40GHz)	全聚达	DLE-161	097	Oct. 28, 2022	Oct. 27, 2023
11	Test Cable	N/A	R-01	N/A	Oct. 28, 2022	Oct. 27, 2023
12	Test Cable	N/A	R-02	N/A	Oct. 28, 2022	Oct. 27, 2023
13	Test Cable	N/A	R-03	N/A	Oct. 28, 2022	Oct. 27, 2023
14	Test Cable	N/A	RF-01	N/A	Oct. 28, 2022	Oct. 27, 2023
15	Test Cable	N/A	RF-02	N/A	Oct. 28, 2022	Oct. 27, 2023
16	Test Cable	N/A	RF-03	N/A	Oct. 28, 2022	Oct. 27, 2023
17	ESG Signal Generator	Agilent	E4421B	N/A	Oct. 21, 2022	Oct. 20, 2023
18	Sgnal Generator	Agilent	N5182A	N/A	Oct. 21, 2022	Oct. 20, 2023
19	Magnetic Field Probe Tester	Narda	ELT-400	0-0344	Nov. 15, 2022	Nov. 14, 2023
20	Wideband Radio Communication Test	R&S	CMW500	106504	Oct. 28, 2022	Oct. 27, 2023
21	MWRF Power Meter Test system	MW	MW100-RPCB	N/A	Oct. 21, 2022	Oct. 20, 2023
22	D.C. Power Supply	LongWei	TPR-6405D	N/A	\	\
23	EMC Software	Frad	EZ-EMC	Ver.EMC-CON 3A1.1	\	\
24	RF Software	MW	MTS8310	V2.0.0.0	\	\
25	Turntable	MF	MF-7802BS	N/A	\	\
26	Antenna tower	MF	MF-7802BS	N/A	\	\

Conduction Test equipment

Item	Kind of Equipment	Manufacturer	Type No.	Serial No.	Last calibration	Calibrated until
1	LISN	R&S	ENV216	101471	Oct. 28, 2022	Oct. 27, 2023
2	LISN	CYBERTEK	EM5040A	E185040014 9	Oct. 28, 2022	Oct. 27, 2023
3	Test Cable	N/A	C01	N/A	Oct. 28, 2022	Oct. 27, 2023
4	Test Cable	N/A	C02	N/A	Oct. 28, 2022	Oct. 27, 2023
5	EMI Test Receiver	R&S	ESRP3	101946	Oct. 28, 2022	Oct. 27, 2023
6	Absorbing Clamp	DZ	ZN23201	N/A	Oct. 28, 2022	Oct. 27, 2023

4. EMC EMISSION TEST

4.1 CONDUCTED EMISSION MEASUREMENT

Test Requirement:	FCC Part15 C Section 15.207
Test Method:	ANSI C63.10:2013
Test Frequency Range:	150KHz to 30MHz
Receiver setup:	RBW=9KHz, VBW=30KHz, Sweep time=auto

4.1.1 POWER LINE CONDUCTED EMISSION LIMITS

(Frequency Range 150KHz-30MHz)

FREQUENCY (MHz)	Limit (dBuV)		Standard
	Quasi-peak	Average	
0.15 -0.5	66 - 56 *	56 - 46 *	FCC
0.50 -5.0	56.00	46.00	FCC
5.0 -30.0	60.00	50.00	FCC

Note:

- (1) The tighter limit applies at the band edges.
- (2) The limit of " * " marked band means the limitation decreases linearly with the logarithm of the frequency in the range.

The following table is the setting of the receiver

Receiver Parameters	Setting
Attenuation	10 dB
Start Frequency	0.15 MHz
Stop Frequency	30 MHz
IF Bandwidth	9 kHz

4.1.2 TEST PROCEDURE

- The EUT was placed 0.8 meters from the horizontal ground plane with EUT being connected to the power mains through a line impedance stabilization network (LISN). All other support equipments powered from additional LISN(s). The LISN provide 50 Ohm/ 50uH of coupling impedance for the measuring instrument.
- Interconnecting cables that hang closer than 40 cm to the ground plane shall be folded back and forth in the center forming a bundle 30 to 40 cm long.
- I/O cables that are not connected to a peripheral shall be bundled in the center. The end of the cable may be terminated, if required, using the correct terminating impedance. The overall length shall not exceed 1 m.
- LISN at least 80 cm from nearest part of EUT chassis.
- For the actual test configuration, please refer to the related Item –EUT Test Photos.

4.1.3 DEVIATION FROM TEST STANDARD

No deviation

4.1.4 TEST SETUP

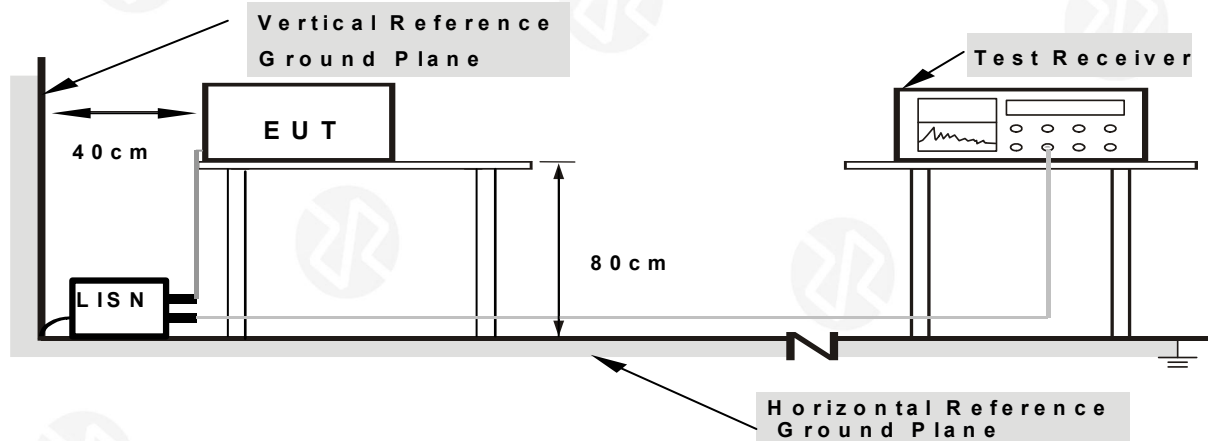

**Note: 1.Support units were connected to second LISN.
2.Both of LISNs (AMN) are 80 cm from EUT and at least 80
from other units and other metal planes**

4.1.5 EUT OPERATING CONDITIONS

The EUT was configured for testing in a typical fashion (as a customer would normally use it). The EUT has been programmed to continuously transmit during test. This operating condition was tested and used to collect the included data.

4.1.6 TEST RESULTS

N/A

4.2 RADIATED EMISSION MEASUREMENT

Test Requirement:	FCC Part15 C Section 15.209				
Test Method:	ANSI C63.10:2013				
Test Frequency Range:	9kHz to 25GHz				
Test site:	Measurement Distance: 3m				
Receiver setup:	Frequency	Detector	RBW	VBW	Value
	9KHz-150KHz	Quasi-peak	200Hz	600Hz	Quasi-peak
	150KHz-30MHz	Quasi-peak	9KHz	30KHz	Quasi-peak
	30MHz-1GHz	Quasi-peak	100KHz	300KHz	Quasi-peak
	Above 1GHz	Peak	1MHz	3MHz	Peak
Peak		1MHz	10Hz	Average	

4.2.1 RADIATED EMISSION LIMITS

According to 15.236(g)

Table 3: Limits for spurious emissions

State	Frequency		
	47 MHz to 74 MHz 87,5 MHz to 137 MHz 174 MHz to 230 MHz 470 MHz to 862 MHz	Other Frequencies below 1 000 MHz	Frequencies above 1 000 MHz
Operation	4 nW	250 nW	1 μW
Standby	2 nW	2 nW	20 nW

4.2.2 DEVIATION FROM TEST STANDARD

No deviation

4.2.3 TEST SETUP

(A) Radiated Emission Test-Up Frequency Below 30MHz

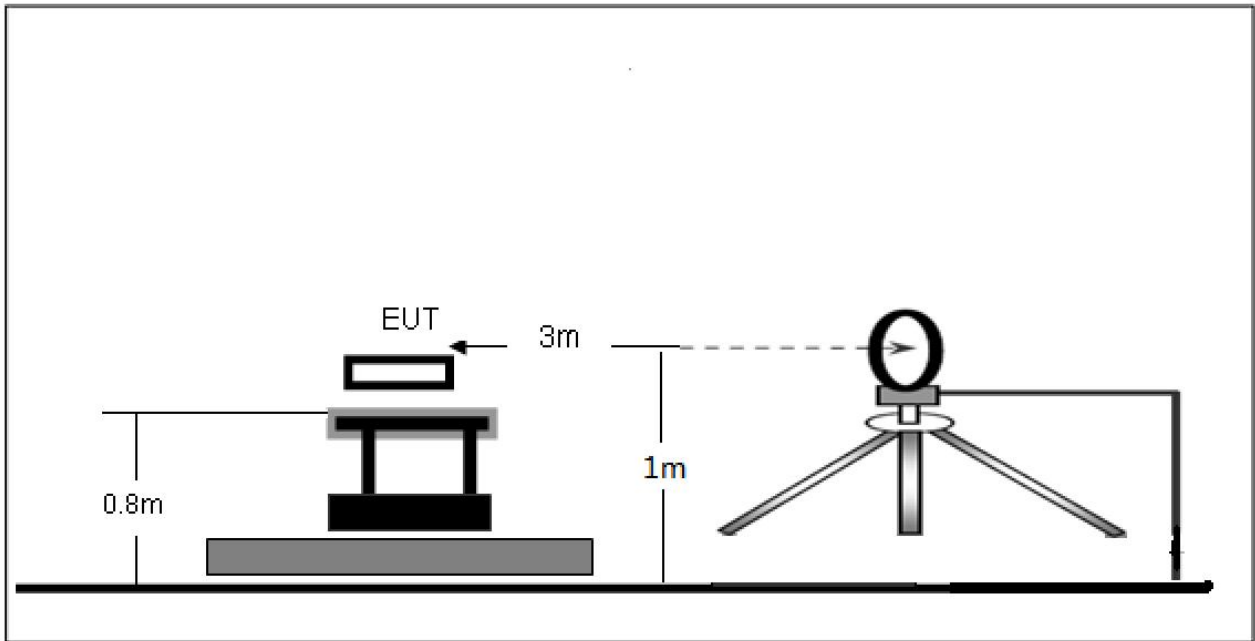

(B) Radiated Emission Test-Up Frequency 30MHz~1GHz

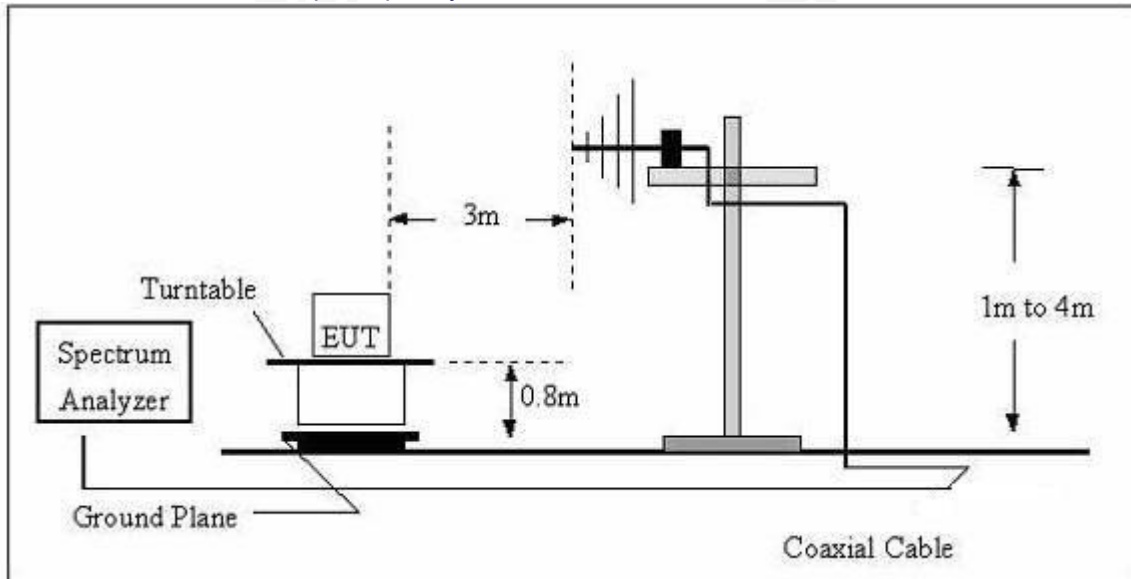

(C) Radiated Emission Test-Up Frequency Above 1GHz

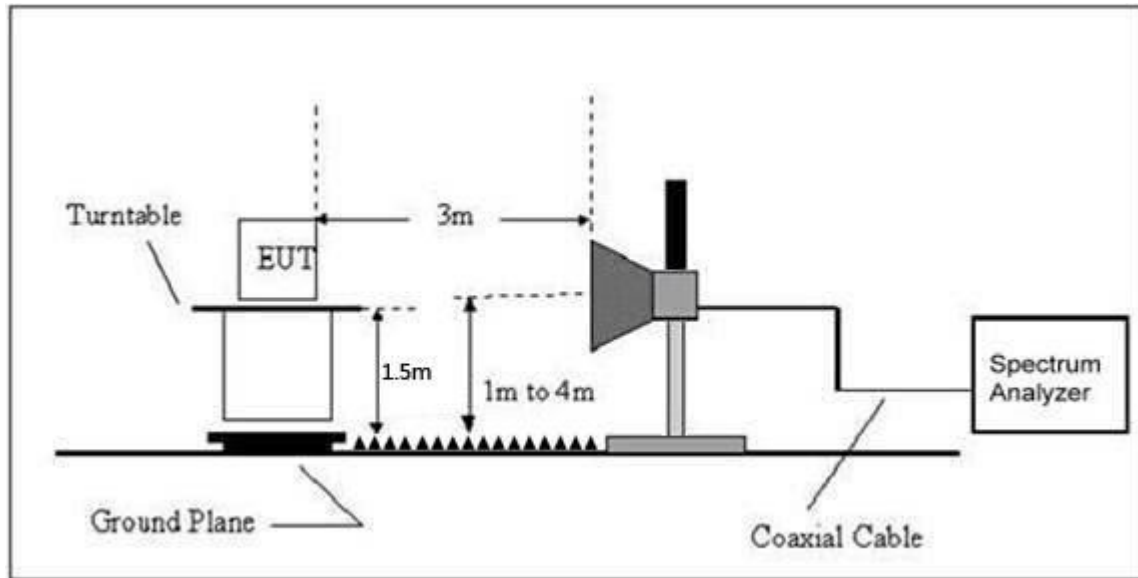

Frequency :9kHz-30MHz
RBW=10KHz,
VBW =30KHz
Sweep time= Auto
Trace = max hold
Detector function = peak

Frequency :30MHz-1GHz
RBW=120KHz,
VBW=300KHz
Sweep time= Auto
Trace = max hold
Detector function = peak

Frequency :Above 1GHz
RBW=1MHz,
VBW=3MHz(Peak), 10Hz(AV)
Sweep time= Auto
Trace = max hold
QP Detector function = peak, AV

4.2.4 TEST PROCEDURE

1. The setup of EUT is according with per TIA/EIA Standard 603 and ANSI C63.4-2014 measurement procedure.
2. The measurement antenna was placed at a distance of 3 meters from the EUT. During the tests, the antenna height and polarization as well as EUT azimuth were varied in order to identify the maximum level of emissions from the EUT. The test was performed by placing the EUT on 3-orthogonal axis.
3. The frequency range up to tenth harmonic of the fundamental frequency was investigated.
4. Remove the EUT and replace it with substitution antenna. A signal generator was connected to the substitution antenna by a non-radiating cable. The absolute levels of the spurious emissions were measured by the substitution.

4.2.5 TEST RESULTS

Radiated Spurious Emission (Between 30MHz – 1GHz)

Temperature :	26 °C	Relative Humidity :	54%
Pressure :	101 kPa	Polarization :	Horizontal
Test Voltage :	DC 3V		
Test Mode :	TX Mode		

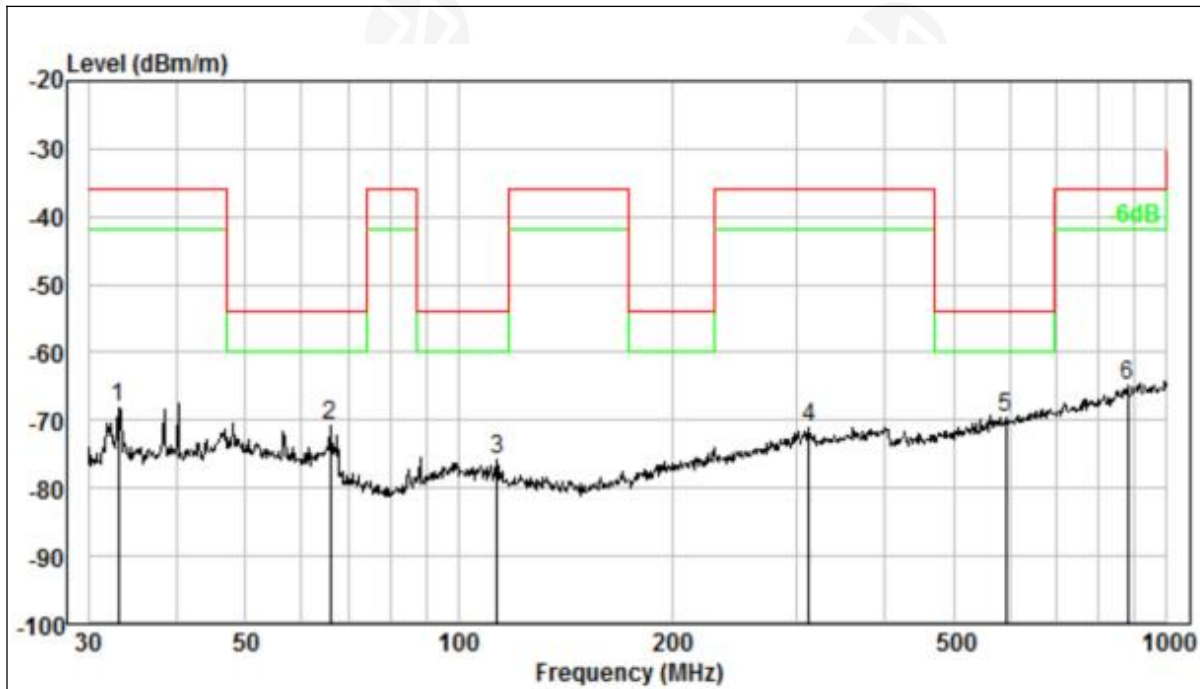

No.	Freq MHz	Cable Loss dB	ANT Factor dB/m	Receiver Reading dBμV	Preamp Gain dB	Emission Level dBμV/m	Limit dBμV/m	Over Limit dB	Remark
1	33.095	0.03	10.89	-59.53	19.50	-68.11	-35.99	-32.12	Peak
2	65.803	0.28	10.24	-61.72	19.52	-70.72	-53.99	-16.73	Peak
3	113.316	0.42	9.60	-66.13	19.54	-75.65	-53.99	-21.66	Peak
4	312.179	0.92	13.57	-65.95	19.65	-71.11	-35.99	-35.12	Peak
5	593.050	1.29	18.58	-69.62	19.79	-69.54	-53.99	-15.55	Peak
6	881.407	1.45	22.28	-68.59	19.94	-64.80	-35.99	-28.81	Peak

Remarks:

- 1.Final Level =Receiver Read level + Antenna Factor + Cable Loss – Pre-amplifier Factor
- 2.The emission levels of other frequencies are very lower than the limit and not show in test report.

Temperature :	26 °C	Relative Humidity :	54%
Pressure :	101 kPa	Polarization :	Vertical
Test Voltage :	DC 3V		
Test Mode :	TX Mode		

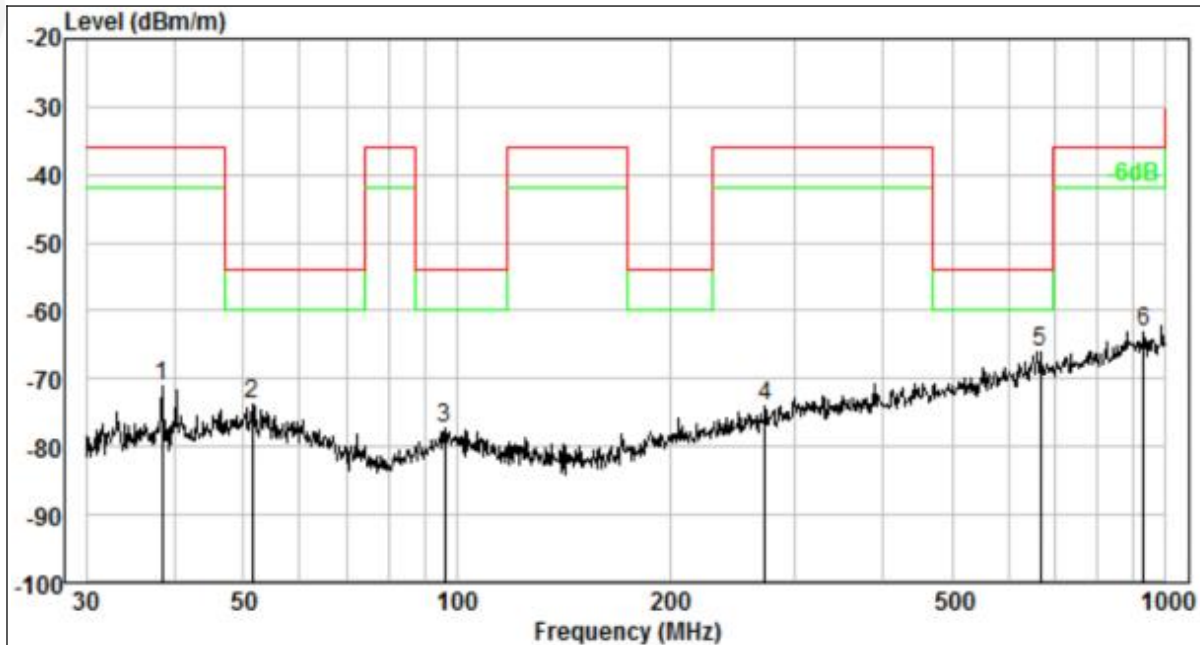

No.	Freq MHz	Cable Loss dB	ANT Factor dB/m	Receiver Reading dBμV	Preamp Gain dB	Emission Level dBμV/m	Limit dBμV/m	Over Limit dB	Remark
1	38.346	0.04	11.89	-63.53	19.50	-71.10	-35.99	-35.11	Peak
2	51.481	0.18	13.12	-67.61	19.51	-73.82	-53.99	-19.83	Peak
3	96.099	0.40	10.30	-68.32	19.53	-77.15	-53.99	-23.16	Peak
4	272.278	0.83	12.80	-68.01	19.62	-74.00	-35.99	-38.01	Peak
5	665.804	1.27	19.69	-67.21	19.83	-66.08	-53.99	-12.09	Peak
6	932.272	1.44	22.76	-67.45	19.97	-63.22	-35.99	-27.23	Peak

Remarks:

- 1.Final Level =Receiver Read level + Antenna Factor + Cable Loss – Pre-amplifier Factor
- 2.The emission levels of other frequencies are very lower than the limit and not show in test report.

Radiated Spurious Emission (Above 1GHz)

Temperature :	26 °C	Relative Humidity :	54%
Pressure :	101 kPa	Polarization :	Horizontal
Test Voltage :	DC 3V		
Test Mode :	TX Mode		

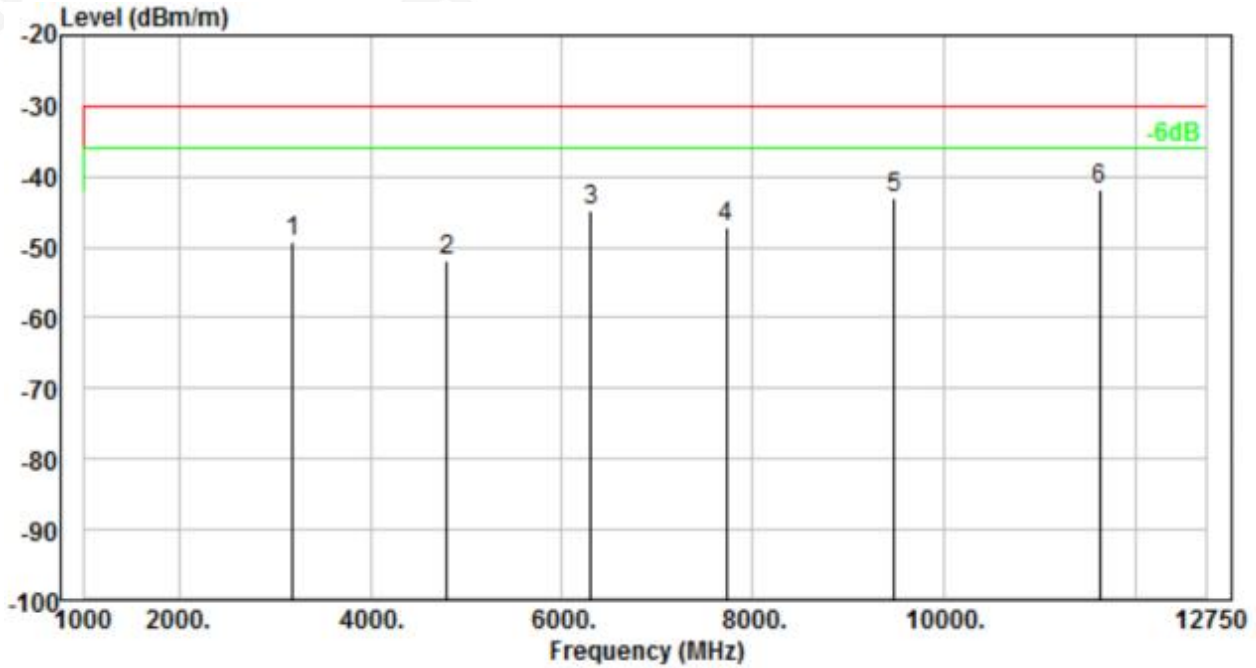

No.	Freq MHz	Cable Loss dB	ANT Factor dB/m	Receiver Reading dBμV	Preamp Gain dB	Emission Level dBμV/m	Limit dBμV/m	Over Limit dB	Remark
1	3184.000	3.31	29.75	-53.53	28.85	-49.32	-29.99	-19.33	Peak
2	4804.000	4.09	32.26	-59.73	28.46	-51.84	-29.99	-21.85	Peak
3	6308.000	5.47	34.49	-56.73	28.03	-44.80	-29.99	-14.81	Peak
4	7728.000	6.61	36.46	-62.77	27.38	-47.08	-29.99	-17.09	Peak
5	9484.000	7.76	37.98	-63.34	25.50	-43.10	-29.99	-13.11	Peak
6	11632.000	8.90	38.72	-64.73	24.87	-41.98	-29.99	-11.99	Peak

Temperature :	26 °C	Relative Humidity :	54%
Pressure :	101 kPa	Polarization :	Vertical
Test Voltage :	DC 3V		
Test Mode :	TX Mode		

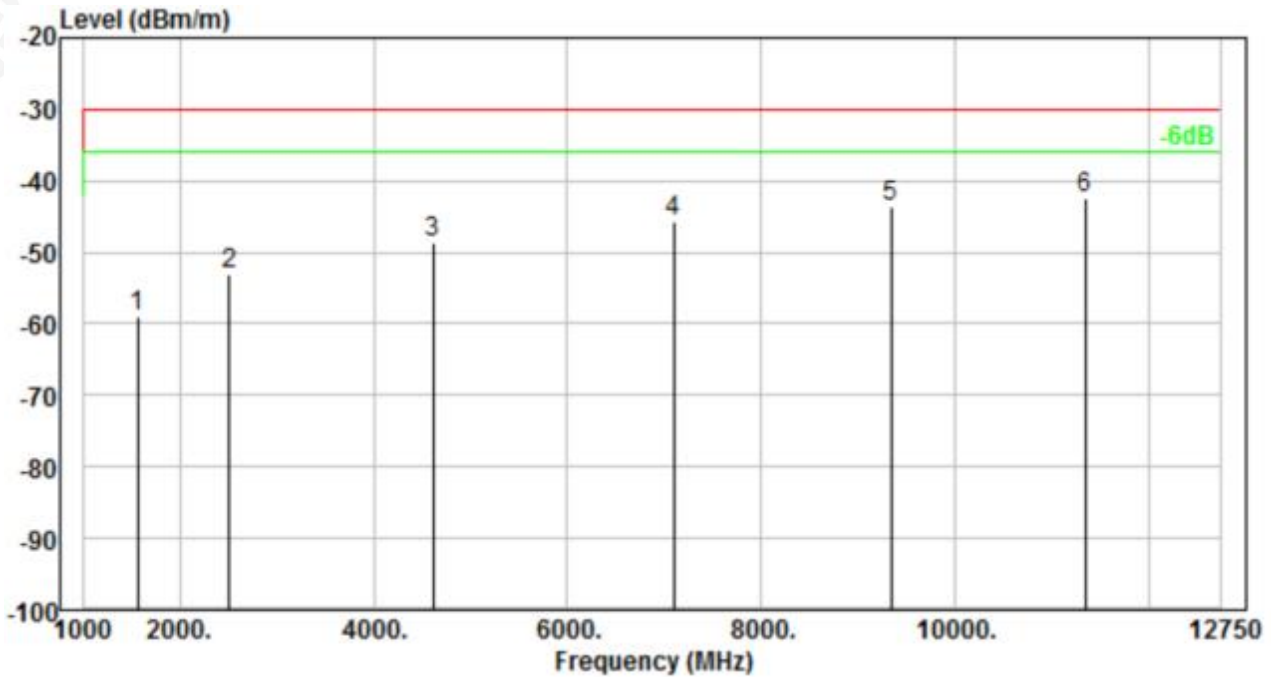

No.	Freq MHz	Cable Loss dB	ANT Factor dB/m	Receiver Reading dB μ V	Preamp Gain dB	Emission Level dB μ V/m	Limit dB μ V/m	Over Limit dB	Remark
1	1564.000	1.97	25.49	-58.62	27.66	-58.82	-29.99	-28.83	Peak
2	2512.000	2.87	27.79	-55.22	28.47	-53.03	-29.99	-23.04	Peak
3	4612.000	4.02	32.03	-56.11	28.53	-48.59	-29.99	-18.60	Peak
4	7096.000	6.13	35.89	-59.65	27.93	-45.56	-29.99	-15.57	Peak
5	9346.000	7.68	37.85	-63.30	25.94	-43.71	-29.99	-13.72	Peak
6	11344.000	8.76	38.89	-65.73	24.45	-42.53	-29.99	-12.54	Peak

5. MAXIMUM RADIATED POWER(EIRP)

5.1 APPLIED PROCEDURES / LIMIT

ACCORDING TO FCC 15.236(D)(1), FOR LOW POWER AUXILIARY STATION OPERATING IN THE 470-608, AND 614-698 MHZ BANDS, IN THE BANDS ALLOCATED AND ASSIGNED FOR BROADCAST TELEVISION AND IN THE 600 MHZ SERVICE BAND: 50 MW EIRP

5.2 TEST PROCEDURE

1. THE MAXIMUM PEAK OUTPUT POWER WAS MEASURED WITH A SPECTRUM ANALYZER CONNECTED TO THE ANTENNA TERMINAL WHILE EUT WAS OPERATING IN UNMODULATED SITUATION.
2. POWER WAS SUPPLIED TO THE BATTERY INPUT CONNECTOR A POWER SUPPLY. THE POWER SUPPLY WAS SET FOR +3.0VDC. THE SPECTRUM ANALYZER WAS CONNECTED AT ANTENNA TERMINAL TO MEASURE RF POWER OF THE CARRIER.
3. A MULTIMETER WAS CONNECTED IN SERIES WITH FINAL RF STAGE TO MEASURE THE CURRENT; A MULTIMETER WAS USED TO MEASURE FINAL RF STAGE SUPPLY VOLTAGE. THEN THE VOLTAGE V.S. CURRENT OF THE FINAL RF STAGE CAN BE SHOWN.

5.3 DEVIATION FROM STANDARD

No deviation.

5.4 TEST SETUP



5.5 EUT OPERATION CONDITIONS

The EUT tested system was configured as the statements of 2.4 Unless otherwise a special operating condition is specified in the follows during the testing.

5.6 TEST RESULTS

Temperature :	26 °C	Relative Humidity :	54%
Pressure :	101kPa	Test Voltage :	DC 3V

Frequency	CONDUCTED OUTPUT POWER (dBm)	ANT GAIN (dBi)	EIRP (dBm)	Limit (dBm)	Result
550MHz	0.988	1.21	2.198	17	PASS
552.48MHz	2.276	1.21	3.486	17	PASS
554.48MHz	0.511	1.21	1.721	17	PASS

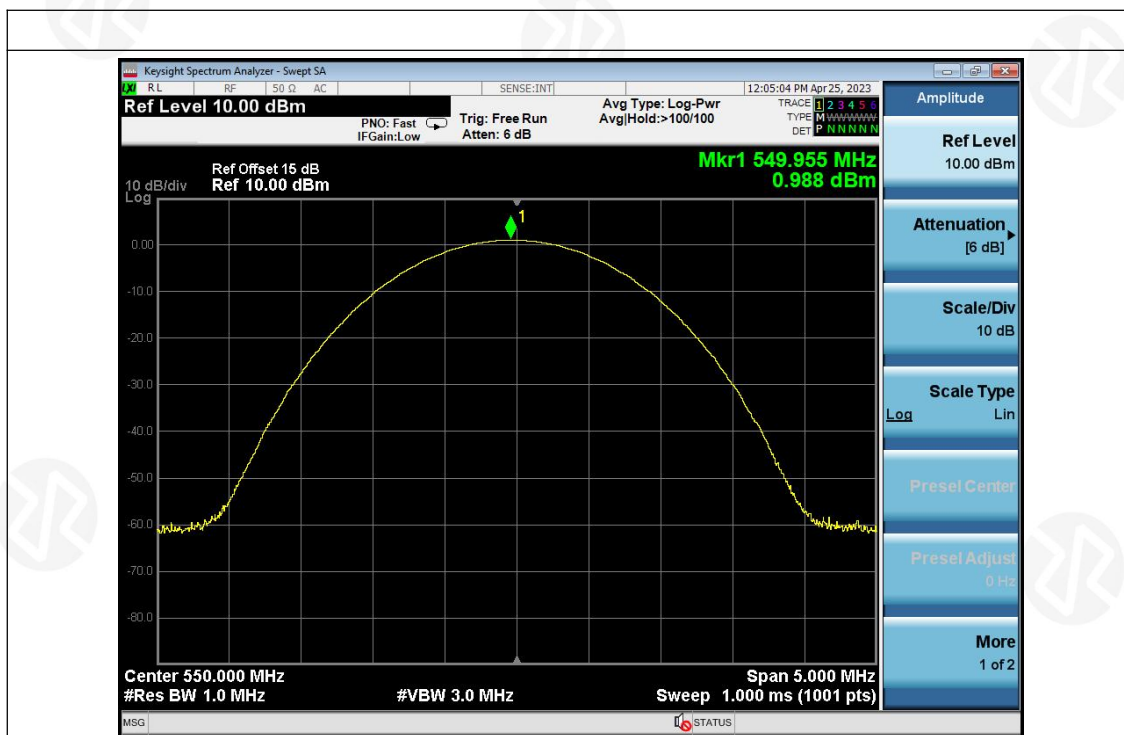

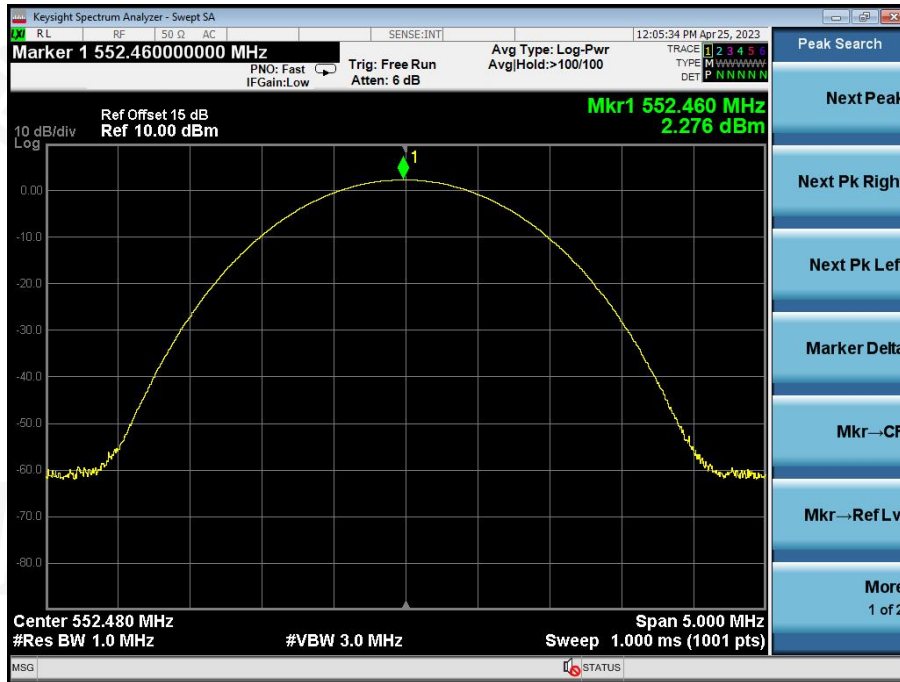

6. CHANNEL BANDWIDTH

6.1 APPLIED PROCEDURES / LIMIT

According to FCC 15.236(f)(2), The operating frequency within a permissible band of operation as defined in paragraph (c) must comply with the following requirements.

- (1) The frequency selection shall be offset from the upper or lower band limits by 25 kHz or an integral multiple thereof.
- (2) One or more adjacent 25 kHz segments within the assignable frequencies may be combined to form a channel whose maximum bandwidth shall not exceed 200 kHz. The operating bandwidth shall not exceed 200kHz.
- (3) Emissions within the band from one megahertz below to one megahertz above the carrier frequency shall comply with the emission mask in Section 8.3 of ETSI EN 300 422-1 V1.4.2 (2011-08) (incorporated by reference, see §15.38). Emissions outside this band shall comply with the limit specified at the edges of the ETSI mask

6.2 TEST PROCEDURE

According to TIA-603 for additional Test Set-Up procedures, the occupied bandwidth of emission was measured with a Spectrum Analyzer connected to the antenna terminal while EUT was operating in 2.5kHz tone at an input level 16 dB greater than that necessary to produce 50 percent modulation. Then mark the -26dB Bandwidth and record it.

6.3 DEVIATION FROM STANDARD

No deviation.

6.4 TEST SETUP

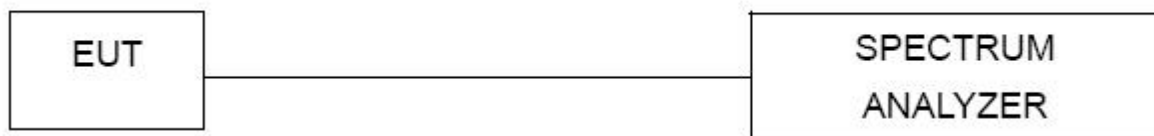

6.5 EUT OPERATION CONDITIONS

The EUT tested system was configured as the statements of 2.4 Unless otherwise a special operating condition is specified in the follows during the testing.

6.6 TEST RESULTS

Temperature :	26 °C	Relative Humidity :	54%
Pressure :	101kPa	Test Voltage :	DC 3V

Frequency (MHz)	-20 bandwidth (KHz)	Limit (KHz)	Result
550	60.37	200	Pass
552.48	60.09	200	Pass
554.48	60.53	200	Pass

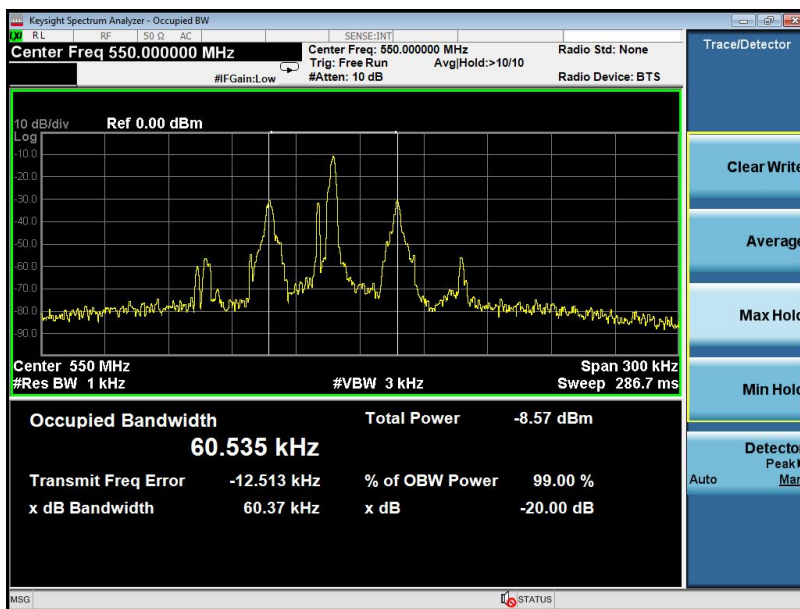

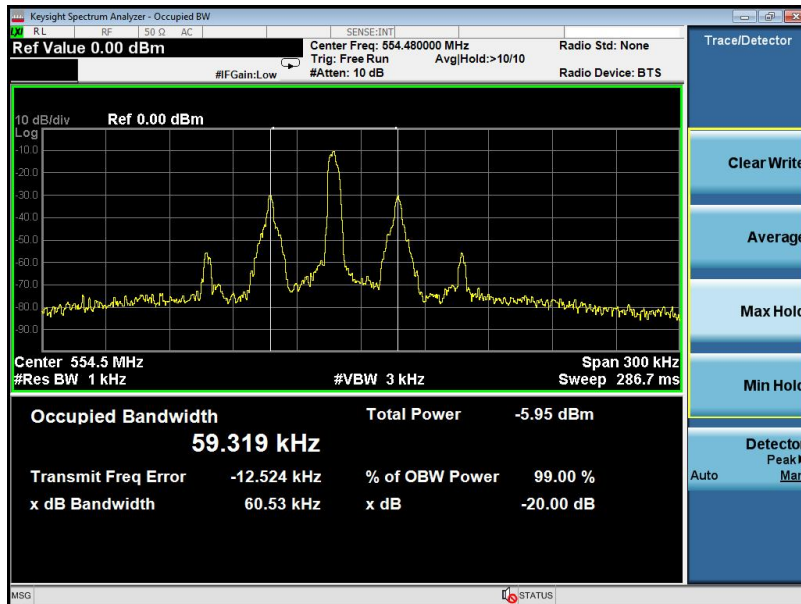
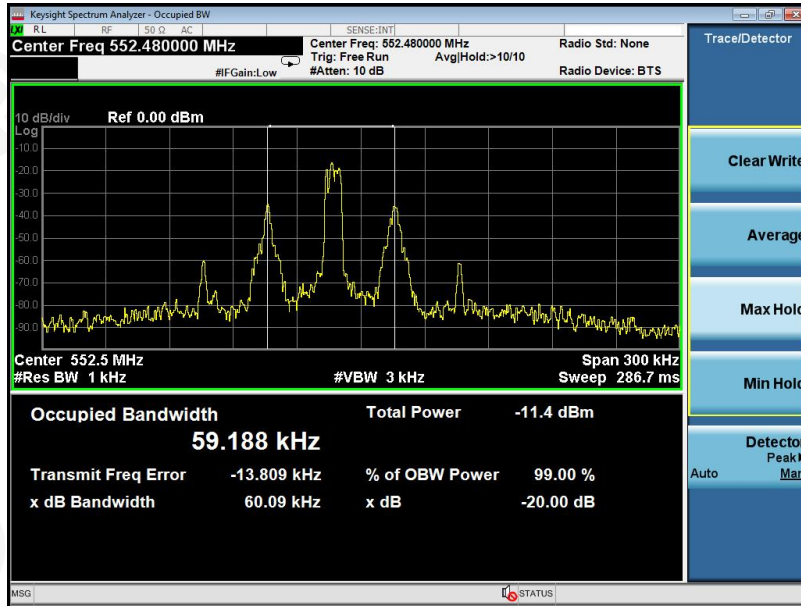

7. NECESSARY BANDWIDTH

7.1 LIMIT

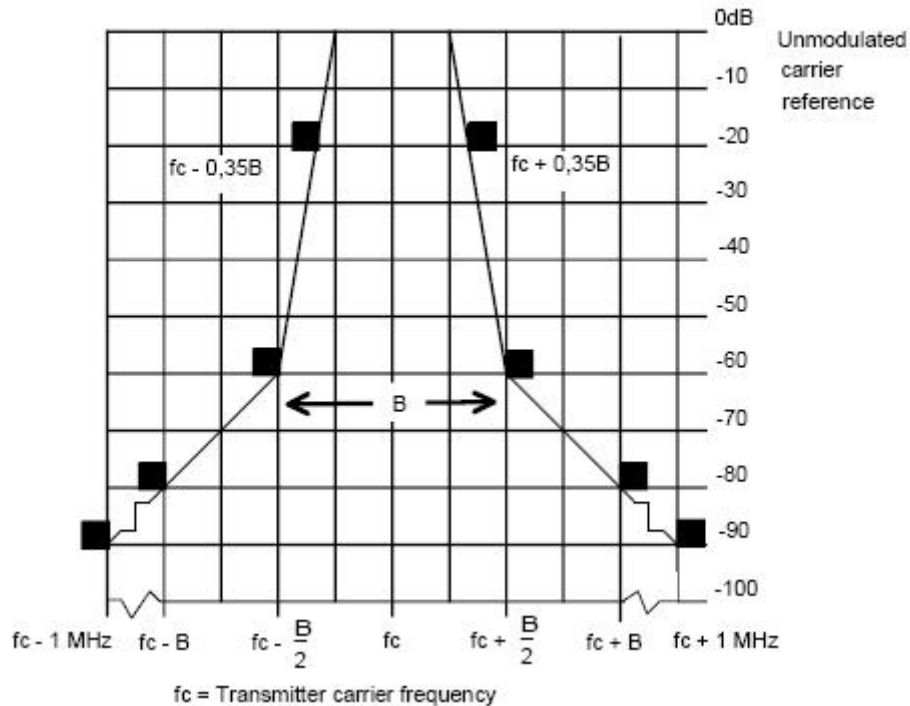

Standard Applicable

According to §15.236 (g) Emissions within the band from one megahertz below to one megahertz above the carrier frequency shall comply with the emission mask in §8.3 of ETSI EN 300 422-1 V1.4.2 (2011-08), Electromagnetic compatibility and Radio spectrum Matters (ERM); Wireless microphones in the 25 MHz to 3GHz frequency range; Part 1: Technical characteristics and methods of measurement. Emissions outside of this band shall comply with the limits specified in section 8.4 of ETSI EN 300 422-1 V1.4.2 (2011-08).

According to ETSI EN 300 422-2 V2.1.1 section 8.3, the transmitter output spectrum shall be within the mask defined in the following figure.

7.2 TEST SETUP



7.3 TEST PROCEDURE

The arrangement of test equipment as shown in figure B.1 shall be used. Note that the noise meter conforms to (quasipeak) without weighting filter (flat).

With the Low Frequency (LF) audio signal generator set to 500 Hz, the audio input level to the DUT shall be adjusted to 8 dB below the limiting threshold (-8 dB (lim)) as declared by the manufacturer.

The corresponding audio output level from the demodulator shall be measured and recorded.

The input impedance of the noise meter shall be sufficiently high to avoid more than 0,1 dB change in input level when the meter is switched between input and output.

The audio input level shall be increased by 20 dB, i.e. to +12 dB (lim), and the corresponding change in output level shall be measured.

It shall be checked that the audio output level has increased by ≤ 10 dB.

If this condition is not met, the initial audio input level shall be increased from -8 dB (lim) in 1 dB steps until the above condition is fulfilled, and the input level recorded in the test report. This level replaces the value derived from the manufacturer's declaration and is defined as -8 dB (lim).

Measure the input level at the transmitter required to give +12 dB (lim).

The LF generator shall be replaced with the weighted noise source to Recommendation ITU-R BS.559-2 [i.3], band-limited to 15 kHz as described in IEC 60244-13 [2], and the level shall be adjusted such that the measured input to the transmitter corresponds to +12 dB (lim).

If the transmitter incorporates any ancillary coding or signalling channels (e.g. pilot-tones), these shall be enabled prior to any spectral measurements.

If the transmitter incorporates more than one audio input, e.g. stereo systems, the second and subsequent channels shall be simultaneously driven from the same noise source, attenuated to a level of -6 dB (lim).

- centre frequency: f_c : Transmitter (Tx) nominal frequency;
- dispersion (Span): $f_c - 1$ MHz to $f_c + 1$ MHz;
- Resolution BandWidth (RBW): 1 kHz;
- Video BandWidth (VBW): 1 kHz;
- detector: Peak hold.

7.4 TEST RESULTS

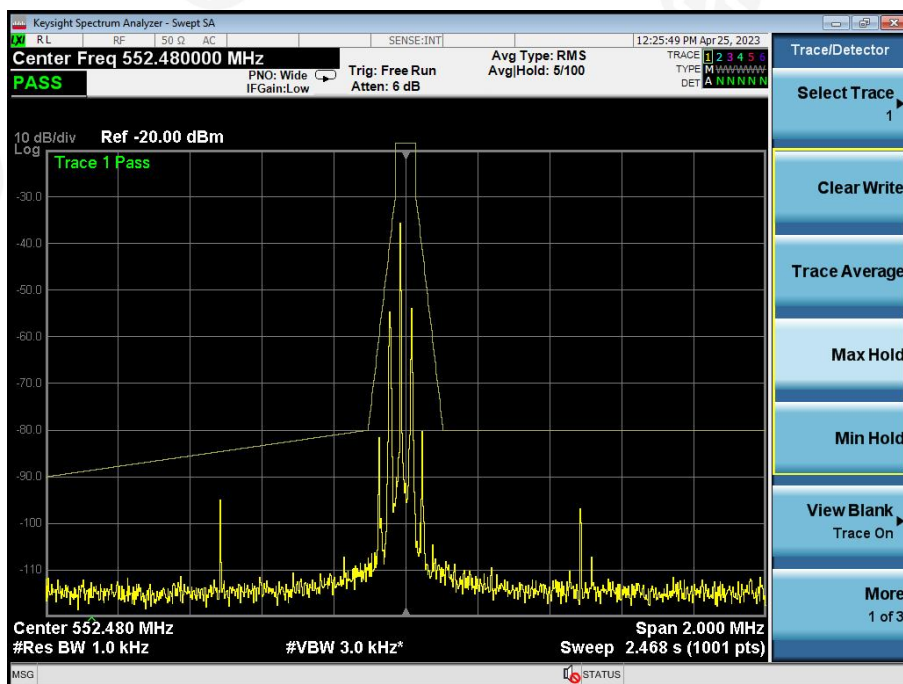
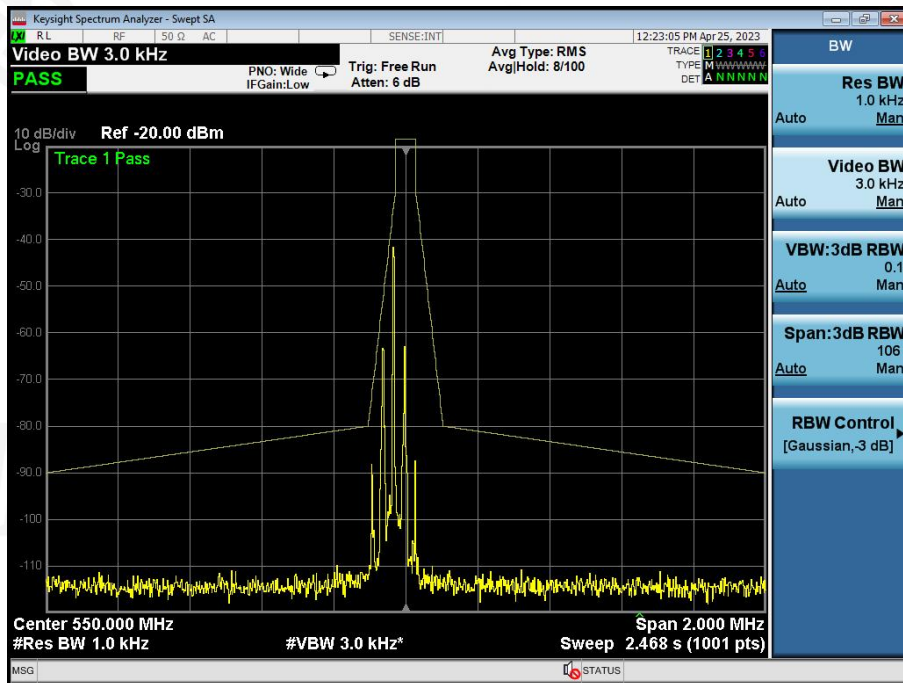

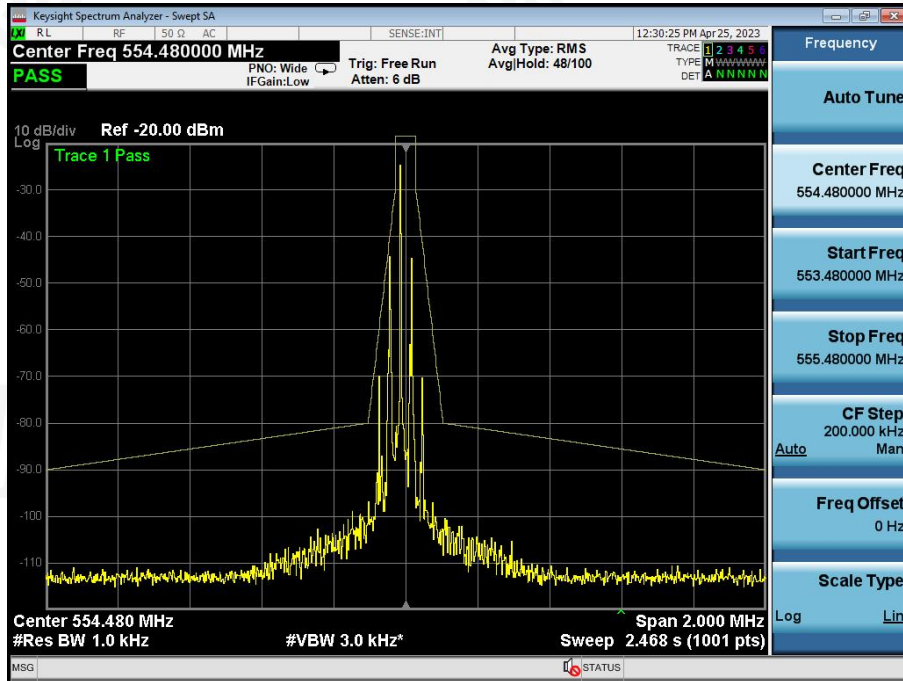

8. FREQUENCY STABILITY

8.1 Limit

$\pm 0.005\% \times 550\text{MHz} = 27.5\text{ KHz}$

$\pm 0.005\% \times 552.48\text{MHz} = 27.6\text{ KHz}$

$\pm 0.005\% \times 554.48\text{MHz} = 27.7\text{ KHz}$

8.2 Standard Applicable

According to FCC 15.236(f)(3), The frequency tolerance of the carrier signal shall be maintained within $\pm 0.005\%$ of the operating frequency over a temperature variation of -20 degrees to $+50$ degrees C at normal supply voltage, and for a variation in the primary supply voltage from 85% to 115% of the rated supply voltage at a temperature of 20 degrees C. Battery operated equipment shall be tested using a new battery

8.3 TEST SETUP



8.4 Test Procedure

1. Setup the configuration of the ambient temperature from -20°C to 50°C with sufficient time. And measure the different power of the EUT with an artificial power from highest to end point voltage.
2. Set frequency counter center frequency to the right frequency needs to be measured band.

8.5 Test Result

Test frequency	Test Conditions		Measure Frequency	Frequency Error	Limit	Result
(MHz)	Voltage (V)	Temperature(°C)	(MHz)	(KHz)	(KHz)	
550	N	N	549.988	-12	±27.5 KHz	Pass
		L	549.987	-13		Pass
		H	549.985	-15		Pass
	L	N	549.988	-12		Pass
		L	549.985	-15		Pass
		H	549.986	-14		Pass
	H	N	549.987	-13		Pass
		L	549.989	-11		Pass
		H	549.988	-12		Pass

Test frequency	Test Conditions		Measure Frequency	Frequency Error	Limit	Result
(MHz)	Voltage (V)	Temperature(°C)	(MHz)	(KHz)	(KHz)	
552.48	N	N	552.468	-12	±27.6 KHz	Pass
		L	552.469	-11		Pass
		H	552.467	-13		Pass
	L	N	552.468	-12		Pass
		L	552.466	-14		Pass
		H	552.467	-13		Pass
	H	N	552.466	-14		Pass
		L	552.468	-12		Pass
		H	552.467	-13		Pass

Test frequency	Test Conditions		Measure Frequency	Frequency Error	Limit	Result
(MHz)	Voltage (V)	Temperature(°C)	(MHz)	(KHz)	(KHz)	
554.48	N	N	554.466	-14	±27.7 KHz	Pass
		L	554.468	-12		Pass
		H	554.467	-13		Pass
	L	N	554.465	-15		Pass
		L	554.466	-14		Pass
		H	554.468	-12		Pass
	H	N	554.465	-15		Pass
		L	554.466	-14		Pass
		H	554.467	-13		Pass

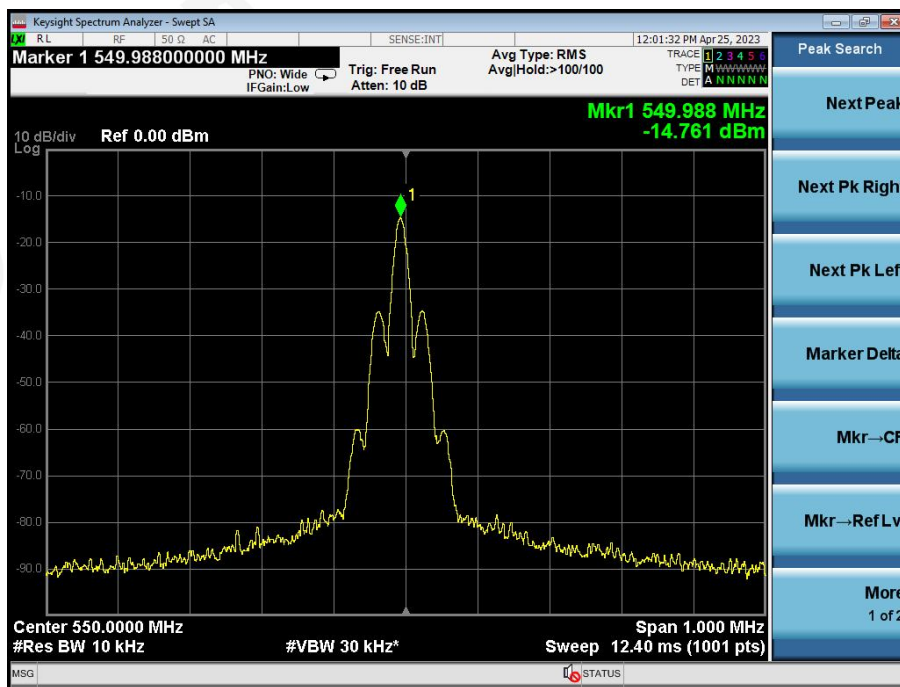

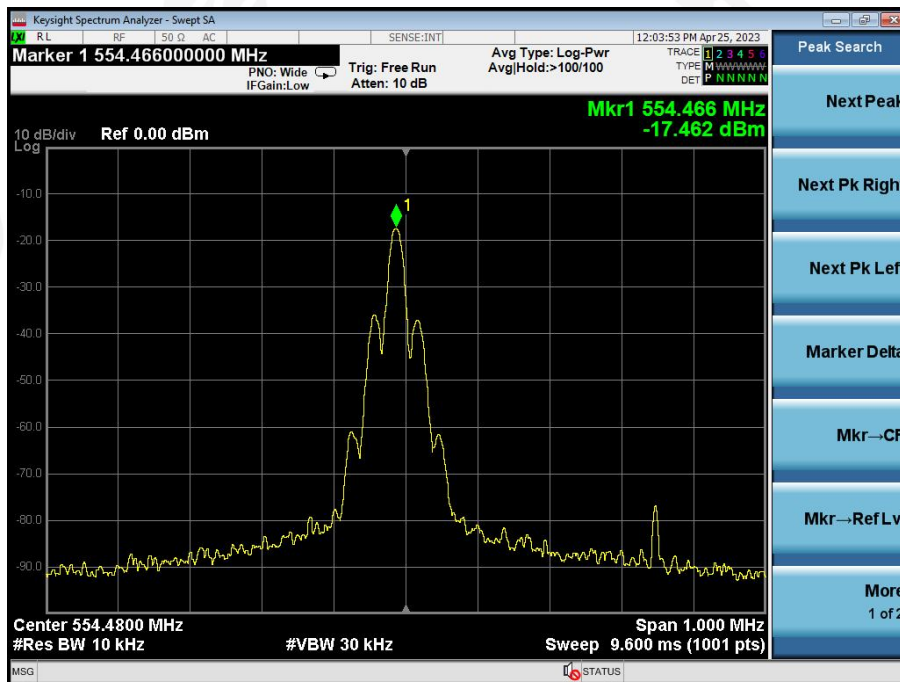
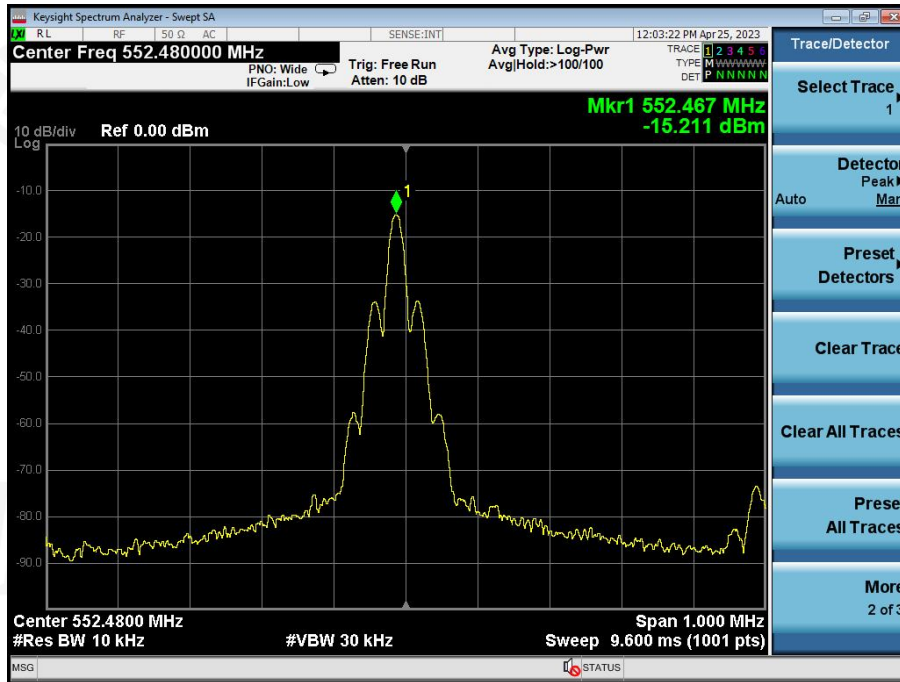

9. ANTENNA REQUIREMENT

Standard requirement:	FCC Part15 C Section 15.203
15.203 requirement: An intentional radiator shall be designed to ensure that no antenna other than that furnished by the responsible party shall be used with the device. The use of a permanently attached antenna or of an antenna that uses a unique coupling to the intentional radiator, the manufacturer may design the unit so that a broken antenna can be replaced by the user, but the use of a standard antenna jack or electrical connector is prohibited.	
EUT Antenna:	
The antennas are internal antenna, the best case gain of the antennas are 1.21dBi, reference to the appendix II for details	

9. TEST SETUP PHOTO

Reference to the appendix I for details.

10. EUT CONSTRUCTIONAL DETAILS

Reference to the appendix II for details.

***** END OF REPORT *****