

惠州启泰电子科技有限公司

Huizhou Qitai Electronic Technology Co., LTD



### SPECIFICATIONS SHEET

### 规格图面

CUSTOMER :	芯狼电子 / Xin lang electronics
客户	
DESCRIPTION :	
品名描述	A1-0292
CUSTOMER P/N :	
客户品名	
PART NUMBER :	
制造商料号	
DATE OF APPLICATION :	2024-7-31
提出日期	

#### CLASSIFICATION OF SPEC. PRESENTATION. ( Tick the relevant box "√" )

规格图面提出区分

- New application                      新规格
- New part is added to accepted specification**                      **新产品规格追加记录**
- Revision of accepted specification                      既存规格图面变更

<b>ACCEPTANCE STAMP ( 客户受领印 )</b>
-----------------------------------

APPROVAL BY 承认	CHECK BY 审查	PREPARE BY 制作
		冯欣

ADDRESS : 3rd Floor, No. 181, Mingyue 2nd Road, Shiwan Town, Boluo County, Huizhou city

TELEPHONE : 0752-6668681

E-MAIL : 839689578@qq.com



惠州启泰电子科技有限公司

Huizhou Qitai Electronic Technology Co., LTD

Specification  
规格内容

CUSTOMER P/N :  
客户品名

中利冠达

PART NUMBER :  
制造商料号

ZLGD-A1-0292

1. DIMENSIONS (外形尺寸) : (Unit: mm)

单位 (Unit) : 毫米 (mm)

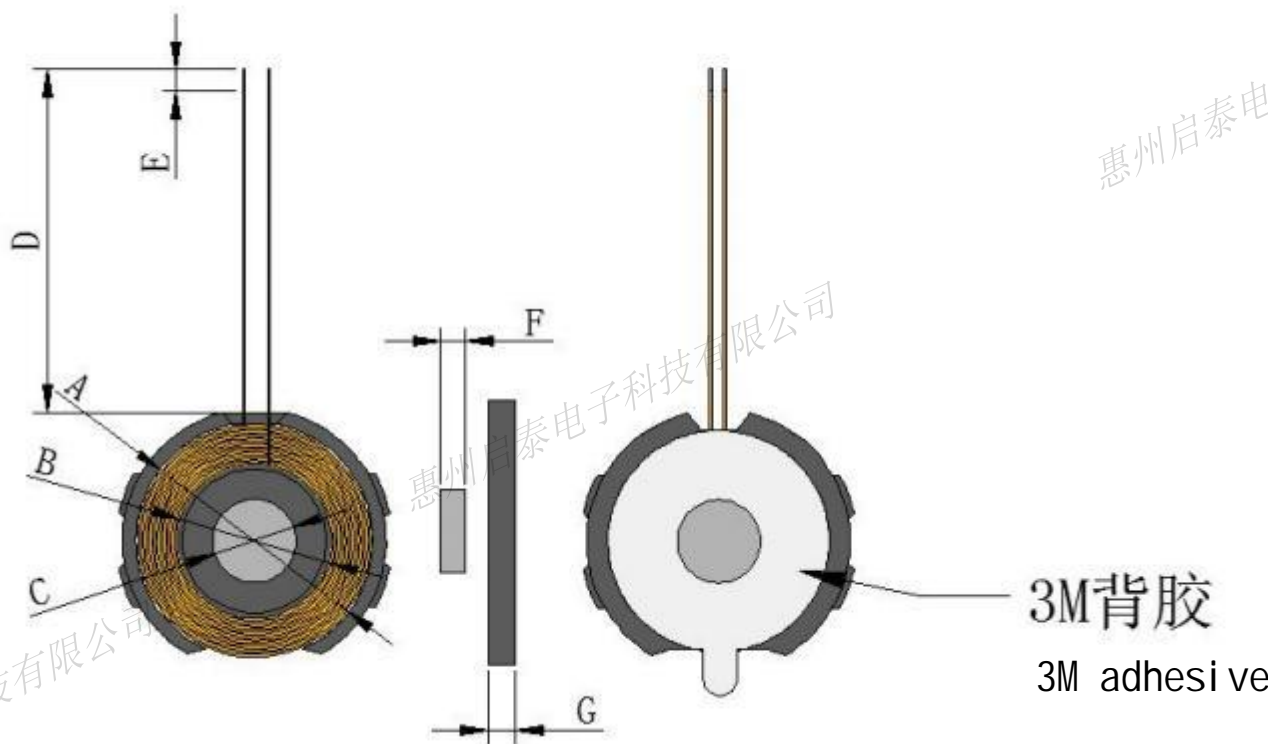

A	B	C	D	E	F	G
21Max	14.5±0.5	7.5±0.5	40±1	2±1	2.2±0.1	2.6MAX

- 背胶为白色背胶， $\phi 18.0$ 。
- 磁铁规格： $\phi 7.5 \times 2.2$  磁场:30
- 软磁出线处开线槽。

APPROVED BY  
承认

CHECKED BY  
审查

PREPARED BY  
制作

DATE  
日期

PAGE  
页码

昆子奇

冯欣

2024-7-31

2 of 3

惠州启泰电子科技有限公司

Huizhou Qitai Electronic Technology Co., LTD

Specification  
规格内容

CUSTOMER P/N :  
客户品名

中利冠达

PART NUMBER :  
制造商料号

ZLGD-A1-0292

2. WINDING DETAILS(绕线详细说明)  
Coil1

圈数 Turns	线径 Wire Dia	绕线方式疏/密 Wdg. Type Spred/Close	绕线方向 Wdg.Direction	相交 是/否 Intersect Yes/Not
13TS	0.08*24P热风绞线 (Hot Air stranded Wire)	密绕 (Close)	逆绕	是 (Yes)

3. 电气特性 (ELECTRICAL CHARACTERISTICS) :

温度 TEMPERATURE:25±10℃,湿度 RELATIVE HUMIDITY:65±10%

序号 NO.	项目 ITEM	端子 TERMINAL	标准 SPECIFICATION	测试条件 TEST FREQUENCY	测试仪器 TEST EQUIPMENTS
Coil 1					
1.	IND	S-F	7.5uh-8.1uh	100kHz/V	UC2906A
2.	Q	S-F	20Min	100kHz/V	UC2906A
3.	DCR	S-F	120Max	100kHz/V	UC2906A



APPROVED BY  
承认

CHECKED BY  
审查

PREPARED BY  
制作

DATE  
日期

PAGE  
页码

昆子奇

冯欣

2024-7-31

3 of 3