

SPECIFICATION

產品型號: DESC	Φ 20.5x41-6.3uH-0.07x100P-45mm50C	版本 Rev: A.0	客戶 CUST: 客戶料号 CUST P/N:	XXX
---------------	-----------------------------------	----------------	----------------------------	------------

一、尺寸 DIMENSION:(mm)

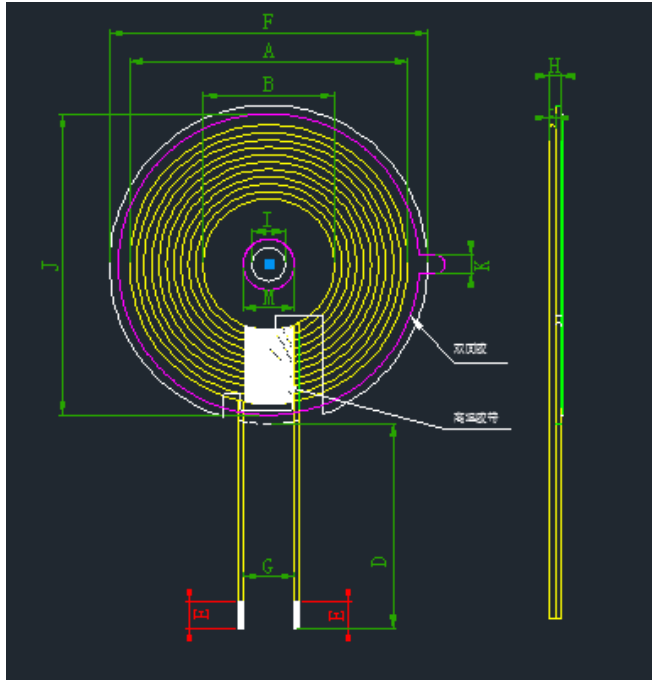

A	41.0±0.5
B	20.5±0.5
C	1.25 Max
D	45±2
E	4±2
F	50±1
G	10.0 ref
H	2.0 Max
I	5.3 ref
M	8.0 ref
J	43±1
K	3.0±1

二、原理图 SCHEMATIC DIAGRAM:

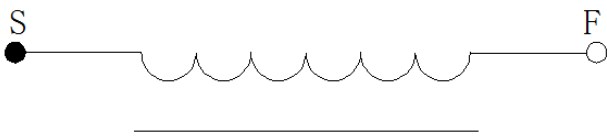

三、绕线参数 Winding Specification:

序号 NO.	端子 TERMINAL		线径 WIRE	圈数 Turns	绕线方向 Winding Direction
1	S	F	0.07*100P	10Ts	CCW

四、电气特性 ELECTRICAL CHARACTERISTICS:

温度 TEMPERATURE:25±10℃, 湿度 RELATIVE HUMIDITY:65±20%

序号 NO.	项目 ITEM	端子 TERMINAL	标准 SPECIFICATION	测试条件 TEST FREQUENCY	测试仪器 TEST EQUIPMENTS
1	IND.	S-F	3.8uH ±20%	100KHz/1.0V	LCZ METER 1062B
2	IND.	S-F	6.3uH ±10%	100KHz/1.0V	LCZ METER 1062B
3	DCR	S-F	≤50mΩ	100KHz/1.0V	UC2836 LCR METER
4	Q 值	S-F	≥60	100KHz/1.0V	UC2836 LCR METER

擬制/日期 PREPARED BY/DATE

審核/日期 CHECKED BY/DATE

