



Jumpstart 5G Product Manual

Release Notes

Date	Version	Description
June 15, 2023	1.0	First Release
June 29, 2023	1.1	Fixed typos and propagation patterns added
July 31, 2023	1.2	NSA details added
August 29, 2023	1.3	Amended supported bands

1. Product Overview 5

- 1.1 Description of Sixfab Jumpstart 5G 5
- 1.2 Target Markets and Applications: 5
- 1.3 Use Cases and Scenarios: 6

2. Getting Started 7

- 2.1 Overview of the operating system requirements for the kit 7
- 2.2 Compatibility with Raspberry Pi OS, necessary drivers, and libraries 7
- 2.3 Establishing a 5G Connection 8
 - 1. Unplug the USB 3.0 Bridge Connector 8
 - 2. Push to remove top cover 9

2.1	Push to remove top cover	9
3.	Plug in the nano type SIM Card (4FF)	9
4.	Assemble the top cover	10
5.	Connect USB 3.0 Bridge Connector	10
6.	Set only your APN to connect the device to network	11
7.	Test Cellular Internet Connection	12
2.4	Warnings	13
3.	Hardware Specifications	14
3.1	Jumpstart 5G Modem Carrier HAT	14
3.1.2	Pinout	14
3.1.3	Pin Descriptions	15
3.1.4	Layout	16
3.1.5	LEDs	17
3.1.6	Buttons	18
3.1.7	5G Module	19
3.2	Supported frequency bands and modes	19
3.3	Maximum data rates and throughput	20
3.4	Network Protocols	20
3.5	Region	20
3.6	Dimensions	21
3.7	Weight	21
3.8	Raspberry Pi	22
3.9	Power	23
3.10	USB Bridge	23
3.11	Detailed specifications of the internal Antenna	24
3.11.1	Return Loss	25
3.11.2	VSWR	25
3.11.3	Ports Isolations	26
3.11.4	Gains/Efficiencies/Polarizations	26
3.11.5	Propagation Patterns	27
4.	Software Specifications	29
4.1	Examples of different network configurations and how to set them up	29
4.1.1	AT+QNWPREFCFG="nr5g_disable_mode"	29
4.1.2	AT+QNWPREFCFG="mode_pref" Network Search Mode Configuration	30
4.1.3	AT+CGDCONT Define PDP Contexts	31
4.2	Detailed network diagnostic and procedures to troubleshoot connection issues	38
4.2.1	AT+QENG Query Primary Serving Cell and Neighbour Cell Information	38
4.2.2	AT+QNWINFO Query Network Information	47
4.2.3	AT+C5GREG 5GS Network Registration Status	48
4.2.4	AT+COPS Operator Selection	50
5.	Compliance and Regulatory	51
5.1	Federal Communications Commission (FCC) regulations in the United States	51
5.2	Conformité Européene (CE) regulations in Europe and (UKCA) regulations in the United Kingdom	52
5.3	Industry Canada (IC) regulations in Canada	52
5.4	International Electro technical Commission (IEC) standards for safety and EMC CB	53
5.5	PCS Type Certification Review Board (PTCRB) standards for cellular devices	53
5.6	Global Certification Forum (GCF) standards for cellular devices	53

6. Warranty and Liability Disclaimers	54
6.1 Description of the warranty provided with the product	54
6.2 Warranty period and limitations	54
6.3 Disclaimer of liability for damages resulting from the use of the product	54
6.4 Limitations on liability for damages caused by defects in the product	54
Reference Documents	56

1. Product Overview

1.1 Description of Sixfab Jumpstart 5G

Sixfab Jumpstart 5G is an IoT computer based on the Raspberry Pi 4, integrated with the Quectel RM502Q-AE modem, a 5G NR Sub-6GHz variant. It combines the power of the Raspberry Pi 4 with high-speed 5G connectivity, making it ideal for various IoT applications. The product features a patent-pending Sixfab designed internal antenna that delivers excellent performance at Sub-6 frequency bands. The electronics are enclosed in a custom plastic enclosure with a specially designed thermal system for optimal performance.

1.2 Target Markets and Applications:

Sixfab Jumpstart 5G is designed to cater to a wide range of markets and applications. It is particularly suitable for industries and sectors that require high-speed and reliable connectivity for their IoT projects. The target markets include:

- **Network Operators:** For network operators, the Jumpstart 5G serves as a valuable testing and evaluation tool. It allows them to assess the performance and capabilities of their 5G networks, experiment with different configurations, and fine-tune their offerings to meet customer demands.
- **IoT Solution Providers:** The product provides IoT solution providers with a platform to prototype and validate their 5G-enabled IoT solutions. It enables them to demonstrate the value and potential of their offerings to potential customers and partners.
- **IoT Developers and Enthusiasts:** The Jumpstart 5G empowers IoT developers and enthusiasts to dive into the possibilities of 5G technology, enabling them to create innovative applications and solutions that leverage the benefits of high-speed, low-latency connectivity.

1.3 Use Cases and Scenarios:

Sixfab Jumpstart 5G provides an accessible and comprehensive platform for exploring and harnessing the capabilities of 5G technology in IoT/eMBB applications. Its flexibility and ease of use make it an invaluable tool for both individuals and organizations looking to embrace the potential of 5G connectivity.

Sixfab Jumpstart 5G can be applied in various use cases and scenarios, including:

- **IoT Prototyping and Testing:** Utilize the Jumpstart 5G to prototype and test new IoT concepts, ensuring compatibility with 5G networks and exploring the potential of emerging technologies like edge computing and AI.
- **Industrial IoT:** Develop industrial IoT applications that harness the power of 5G for real-time monitoring, predictive maintenance, and remote asset management in sectors like manufacturing, logistics, and utilities.
- **Smart City Solutions:** Explore and develop smart city applications that leverage 5G connectivity, such as smart transportation systems, intelligent energy management, and efficient public services.
- **Remote Monitoring and Surveillance:** Build solutions for remote monitoring and surveillance, enabling real-time video streaming, remote control, and situational awareness across various industries, including security, agriculture, and infrastructure.
- **High-Speed Data Transfer:** Test and optimize applications that require high-speed data transfer, such as multimedia streaming, cloud-based services, and large-scale data analytics.
- **Digital Signage:** Jumpstart 5G can be used to power 5G-enabled digital signage solutions, allowing for dynamic and interactive content delivery in retail, hospitality, transportation, and other industries. It enables real-time content updates, remote management, and personalized customer experiences.

2. Getting Started

This section will lead you step by step to create a cellular connection with the Sixfab Jumpstart 5G.

2.1 Overview of the operating system requirements for the kit

The Jumpstart 5G package includes a pre-configured operating system, which is Raspberry Pi OS. This ensures you have a seamless experience with the 5G functionality right out of the box. Hence, there is no necessity for you to install the

operating system image onto the SD card.

2.2 Compatibility with Raspberry Pi OS, necessary drivers, and libraries

Raspberry Pi OS is based on Debian, so modules that are compatible with Debian-based systems are generally compatible with Raspberry Pi OS as well. The cellular module has built-in support in the Linux kernel and is recognized automatically by the system. No additional drivers are required.

There are specific libraries or software tools available to facilitate communication with the cellular module such as [atcom](#), [minicom](#) etc. are already installed. With these tools, a user can send AT commands to the cellular module and establish any communication related to the module.

2.3 Establishing a 5G Connection

Follow the steps below to proceed with the installation of the Jumpstart 5G hardware for establishing a 5G connection.

1. Unplug the USB 3.0 Bridge Connector

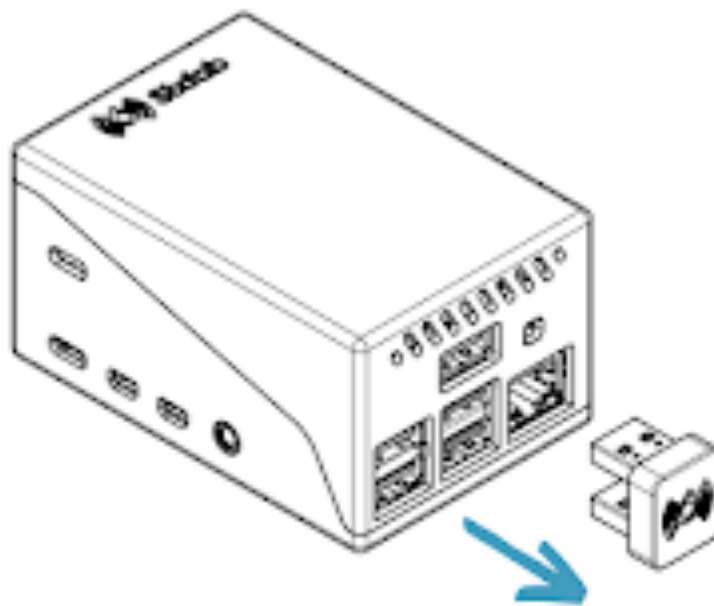

2. Push to remove top cover

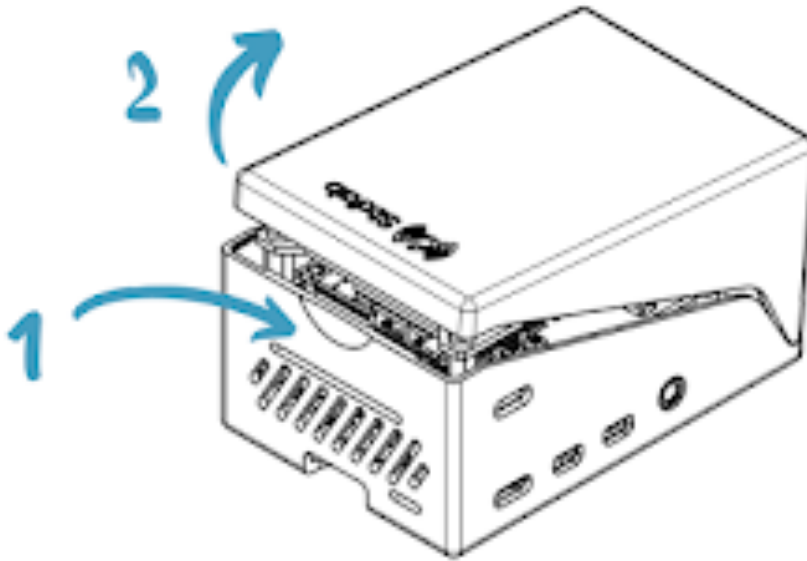

2

3. Plug in the nano type SIM Card (4FF)

Be careful with corner marking!

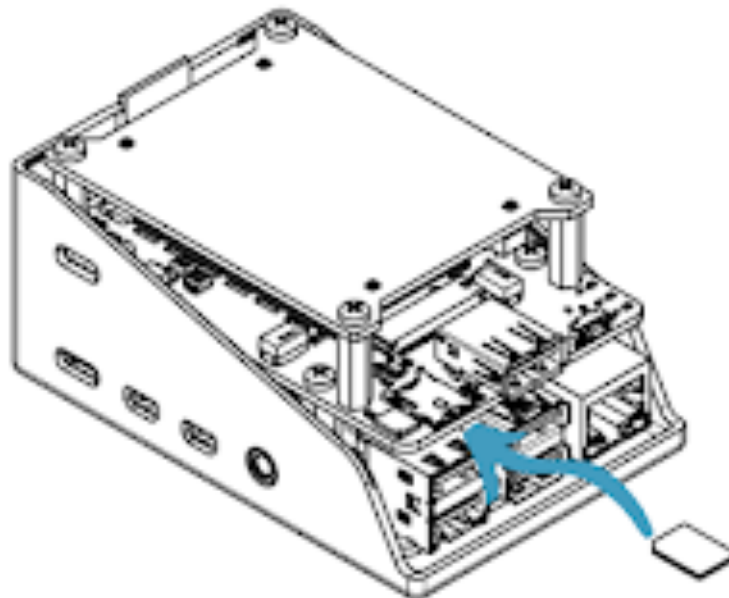

3

4. Assemble the top cover

Align the bottom edge first!

4

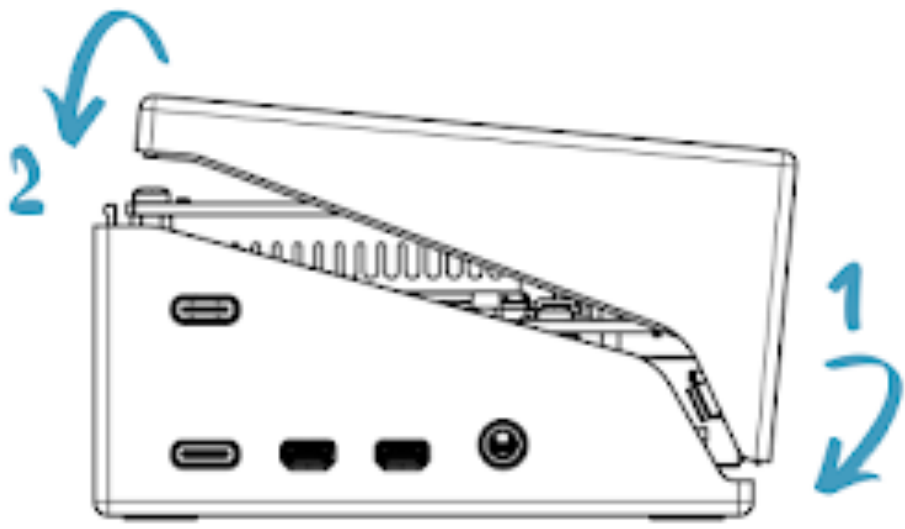

5. Connect USB 3.0 Bridge Connector

Plug in a micro HDMI and keyboard/mouse to access the desktop GUI and before powering up the system.

Then plug 2x power adapters in Type-C connectors to power the system on!

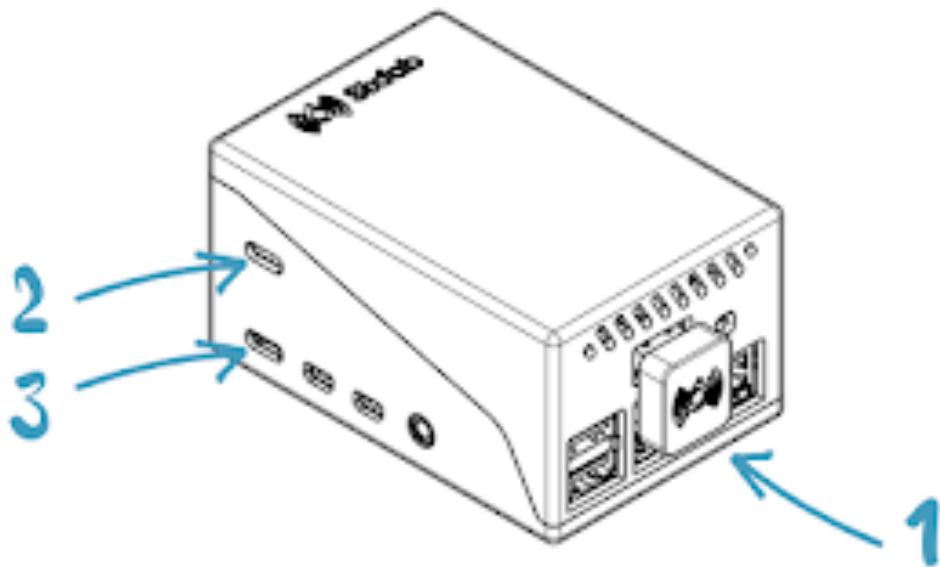

6. Set only your APN to connect the device to network

SSH Login

If you want to connect to Jumpstart 5G using SSH, the following are the credentials:

Username	Password
pi	raspberry

Please use the provided credentials to establish an SSH connection to Jumpstart 5G. For your security, remember to change these credentials to something unique and secure.

- Open the terminal

Run the command including your network operator's APN:

```
atcom AT+CGDCONT=1,\"IPV4V6\", \"YOUR_APN\"
```

- Reset the modem by typing:

```
atcom AT+CFUN=1,1
```

Wait 50 seconds for the modem to fully function and a few minutes for network registration.

7. Test Cellular Internet Connection

Once the internet is active you should see usbX in your internet interface. You can use `ifconfig` or `ipaddr` and look for usbX interface.

Now check the assigned IP address and test the connection.

```
pi@raspberrypi:~ $ ifconfig usb0
usb0: flags=4163<UP,BROADCAST,RUNNING,MULTICAST> mtu 1500
    inet 192.168.225.60 netmask 255.255.255.0 broadcast 192.168.225.255
    inet6 fe80::8543:f6a0:e678:2e20 prefixlen 64 scopeid 0x20<link>
    ether 4a:aa:f8:62:36:bb txqueuelen 1000 (Ethernet)
    RX packets 73 bytes 5047 (4.9 KiB)
    RX errors 0 dropped 0 overruns 0 frame 0
    TX packets 100 bytes 15116 (14.7 KiB)
    TX errors 0 dropped 0 overruns 0 carrier 0 collisions 0
```



```
pi@raspberrypi:~ $ ping -I usb0 sixfab.com -c 5
PING sixfab.com (104.26.9.221) from 192.168.225.60 usb0: 56(84) bytes of data.
64 bytes from 104.26.9.221 (104.26.9.221): icmp_seq=1 ttl=52 time=209 ms
64 bytes from 104.26.9.221 (104.26.9.221): icmp_seq=2 ttl=52 time=202 ms
64 bytes from 104.26.9.221 (104.26.9.221): icmp_seq=3 ttl=52 time=192 ms
64 bytes from 104.26.9.221 (104.26.9.221): icmp_seq=4 ttl=52 time=193 ms
64 bytes from 104.26.9.221 (104.26.9.221): icmp_seq=5 ttl=52 time=195 ms

--- sixfab.com ping statistics ---
5 packets transmitted, 5 received, 0% packet loss, time 9ms
rtt min/avg/max/mdev = 191.895/198.244/209.463/6.636 ms
```

Enjoy being connected with Sixfab Jumpstart 5G!

2.4 Warnings

- 5G uplink and downlink rates depend on the network operator, cell tower, device location, antenna surroundings, and operating system compute load.
- Do not use other than official Raspberry Pi power supplies or Sixfab power adapters to protect electronics and achieve maximum performance.
- Do not block the airflow of device to prevent overheating. The cooling fan automatically works with adjusted speed right out of the box. It should be reprogrammed if a fresh OS image has been overwritten to micro SD cards or the script has changed.
- The device contains highly sensitive electronic circuitry and is an Electrostatic Sensitive Device (ESD). Handling it without proper ESD protection may destroy or damage it permanently.
- The antenna is located at the top of the device. Please do not put it upside down or place anything nearby the device that could affect the signal.
- Please use the Sixfab Jumpstart 5G SIM removal tool included to eject the SIM card to avoid damaging the slot.

3. Hardware Specifications

3.1 Jumpstart 5G Modem Carrier HAT

The detailed specifications of the Jumpstart 5G HAT are provided below.

3.1.2 Pinout

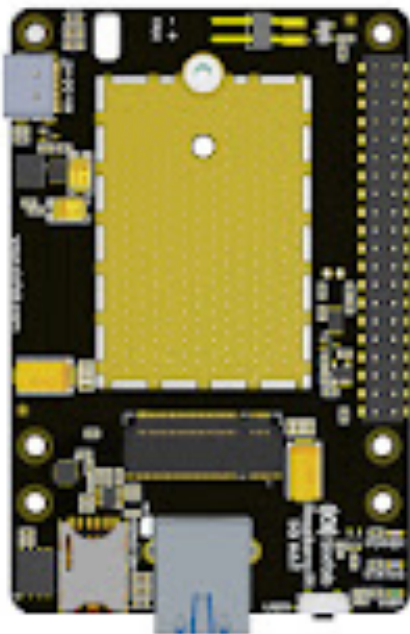

	3V3	1		23	5V	
	GPIO 2	2		24	5V	
	GPIO 3	3		25	GND	
	GPIO 4	4		26	UART TX	
	GND	5		27	UART RX	
	GPIO 17	17		28	GPIO 18	
RAM	GPIO 27	27		29	GND	
PWR DISABLE	GPIO 22	22		30	GPIO 23	
	3V3	19		31	GPIO 24	
	GPIO 16	16		32	GND	
	GPIO 9	9		33	GPIO 25	
	GPIO 11	11		34	GPIO 8	
	GND	13		35	GPIO 7	
	RESERVED	21		36	RESERVED	
	GPIO 8	8		37	GND	
	GPIO 6	6		38	GPIO 12	
SIM SELECT	GPIO 13	13		39	GND	
POWER LED	GPIO 19	19		40	GPIO 16	
PCP	GPIO 26	26			GPIO 20	USER BUTTON
	GND	10			GPIO 21	USER LED

3.1.3 Pin Descriptions

Pin Number	BCM Pin	Pin Name	Description

33	GPIO13	SIM Select	It is used to toggle between the nano SIM card and the embedded SIM. Default state is LOW selecting nano SIM. Set to HIGH for embedded SIM. It requires module reboot using FCP pin.
13	GPIO27	Fan ON-OFF / PWM Control	The pin turns on the FAN when set to HIGH. Default is LOW. PWM can control fan speed. In the included Raspberry Pi OS, fan is set to full speed at 60°C. At 50°C, fan turns off.
37	GPIO26	5G Module FCP	This pin controls power on/off of the module. Setting it to HIGH powers off the module after 10 seconds. Setting it to LOW initiates power-on sequence of the module and is fully functional after 50 seconds. Default state of the pin is LOW.
40	GPIO21	User LED	When the pin is pulled HIGH, the LED lights up.
38	GPIO20	User Button	This pin is pulled to the default HIGH state. When the button is pressed, the pin is pulled to the LOW.
35	GPIO19	Power LED Off	If you want to turn off the Power LED, you can set this pin to HIGH. By default, the Power LED will always be on.
15	GPIO22	Power Disable	Set the pin to HIGH to completely cut off power from the HAT, disabling power consumption. In case of module unresponsiveness, use this method to power cycle the HAT. Setting the pin to LOW supplies power to the HAT. Default state of the pin is LOW.

3.1.4 Layout



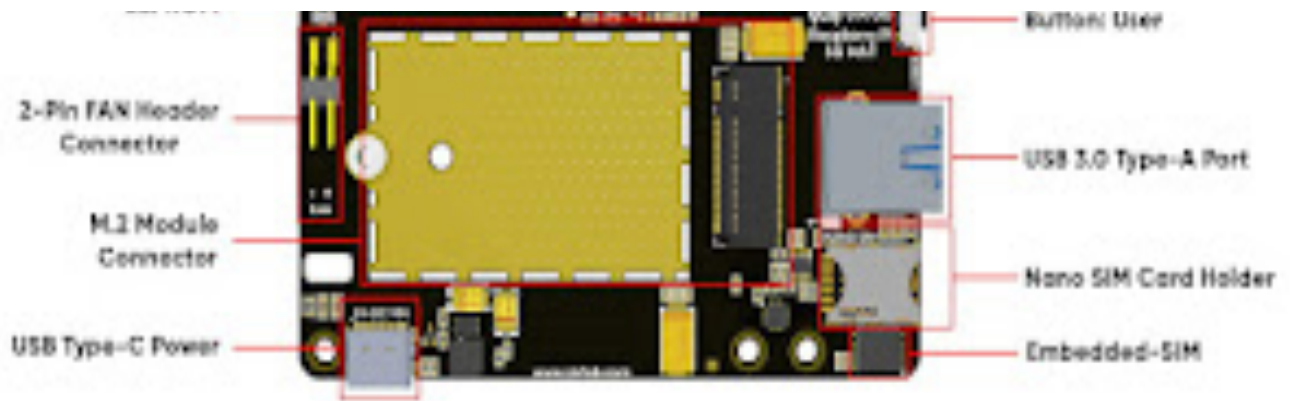

3.1.5 LEDs





- **Power LED:** The LED indicates power status of the HAT and can also be controlled via GPIO19. Refer to the pin descriptions table for instructions.
- **Status LED:** The LED indicates the RF function of the module. Turns on when RF Function is on. Turned off when the SIM is not powered or RF function is disabled.
- **User LED:** It is a programmable user-led can be controlled from the GPIO21 of Raspberry Pi for debugging or just fun.

3.1.6 Buttons



- **User Button:** It is a programmable user button that is connected to GPIO20. It reads HIGH by default.

3.1.7 5G Module

The module used in Jumpstart 5G is the Quectel M.2 5G Sub-6 RM502Q-AE module. It is attached to the HAT as shown below.

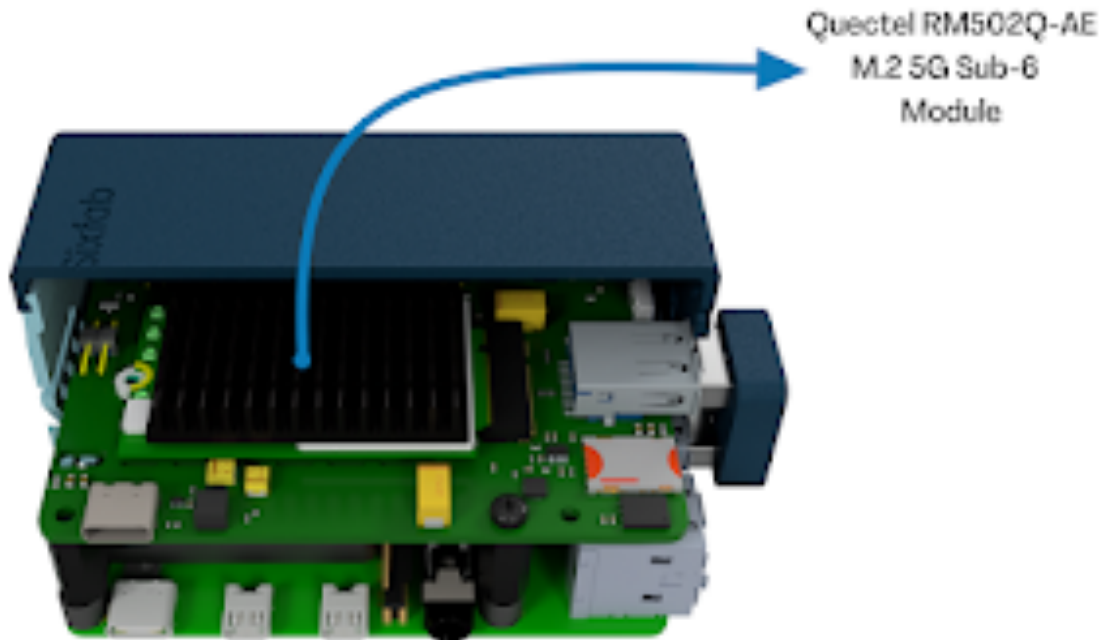

3.2 Supported frequency bands and modes

5G NR: 3GPP Release 15 NSA/SA operation, Sub-6 GHz

5G NR
NSA: n41
SA: n41/n77/n78

3.3 Maximum data rates and throughput

5G SA Sub-6	5G NSA Sub-6
Downlink 4.2 Gbps; Uplink 450 Mbps	Downlink 5.0 Gbps; Uplink 600/650 Mbps

3.4 Network Protocols

TCP/UDP/FTP/HTTP/HTTPS/PING/SMS

3.5 Region

Global

3.6 Dimensions



For detailed dimensions of the product, please visit the [Sixfab Jumpstart 5G GitHub repository](#).

3.7 Weight

The total weight of the product is 207.5 grams.

3.8 Raspberry Pi

Jumpstart 5G includes the official **Raspberry Pi 4 8GB** model. Here are its specifications:

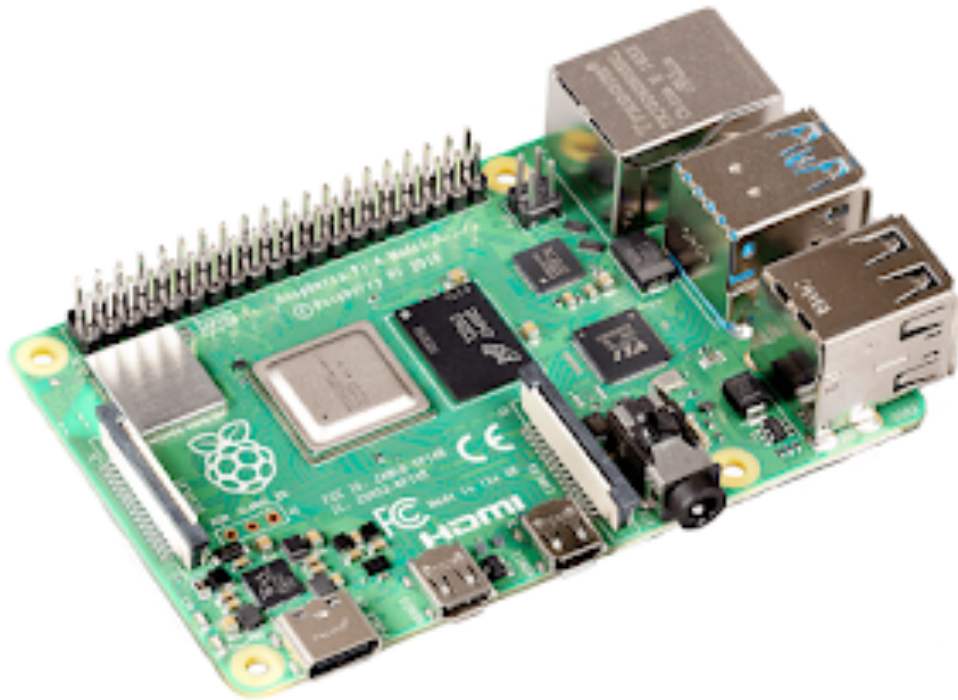

- Broadcom BCM2711, Quad core Cortex-A72 (ARM v8) 64-bit SoC @ 1.8GHz
- 8GB LPDDR4-3200 SDRAM
- Gigabit Ethernet
- 2 USB 3.0 ports; 2 USB 2.0 ports.
- 2 × micro-HDMI ports
- 2-lane MIPI DSI display port

- 2-lane MIPI CSI camera port
- 4-pole stereo audio and composite video port
- Micro-SD card slot for loading operating system and data storage

3.9 Power

Sixfab encourages to use of official power adapters for the product. The detailed power analysis of the product will be updated here soon.

3.10 USB Bridge

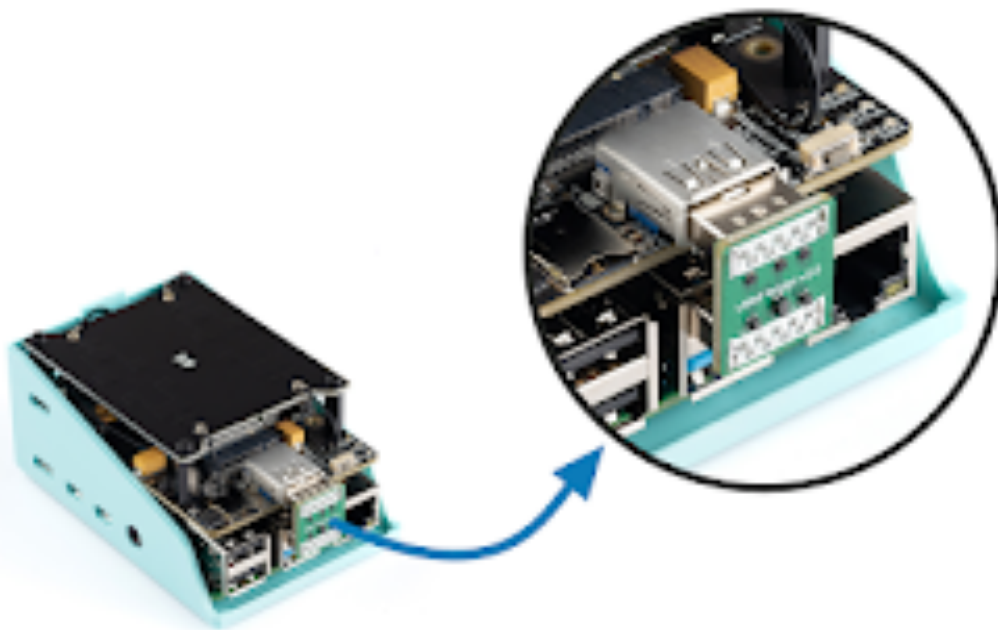

The USB Bridge serves the purpose of connecting the 5G module with the USB 3.0 port of the Raspberry Pi. This design choice was made in favor of using a USB cable, as it provides a robust, aesthetic, and space-saving solution. Rather than a standard straight cable connection, the USB Bridge has been specifically designed with EMI/EMC filtering components to ensure faster and more efficient data transmission.

3.11 Detailed specifications of the internal Antenna

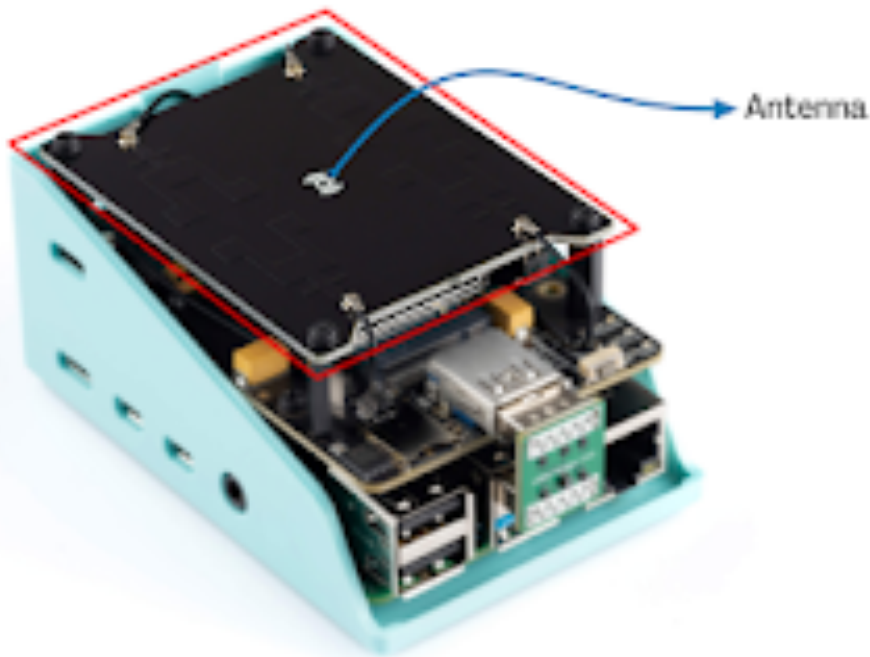

This antenna has been specifically designed and produced by Sixfab engineers, focusing on 5G bands and frequencies, exclusively for the Jumpstart 5G product.

The connections between the antenna and the 5G module are established using MHF4 connectors and custom-made MHF4 cables.

For in-depth technical specifications regarding the antenna, please consult the details provided below.

The designed 5G terminal antenna is 4X MIMO Micro-strip antenna, which operates over:

- 5G NR SA bands: n41 (2469-2690MHz), n77 ([3300-3800](#) MHz), n78 ([3300-4200](#) MHz), n71 (617-698 MHz)
- 5G NR NSA bands: n41 (NSA combos are DC_2A_n41A, DC_12A_n41A, and DC_66A_n41A)

3.11.1 Return Loss

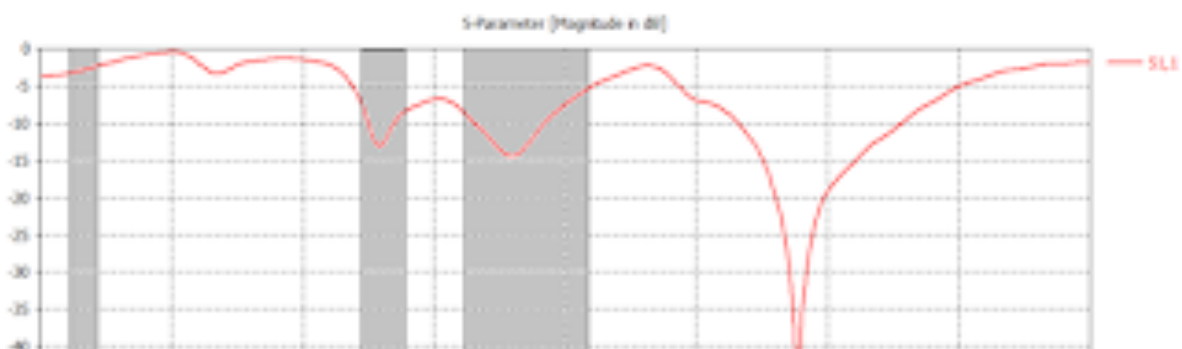



Frequency (MHz)	2579	3550	3750	600
Value (dB)	-14.1	-14.3	-14.62	-3

3.11.2 VSWR

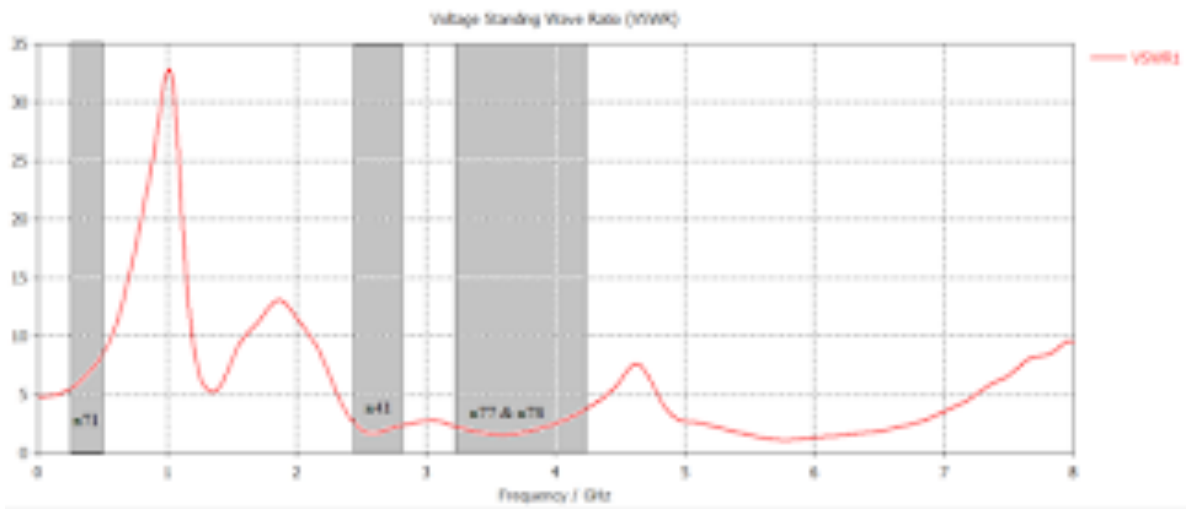

Frequency (MHz)	2579	3550	3750	600
Value (dB)	1.07:1	1.29:1	1.32:1	8.21:1

3.11.3 Ports Isolations

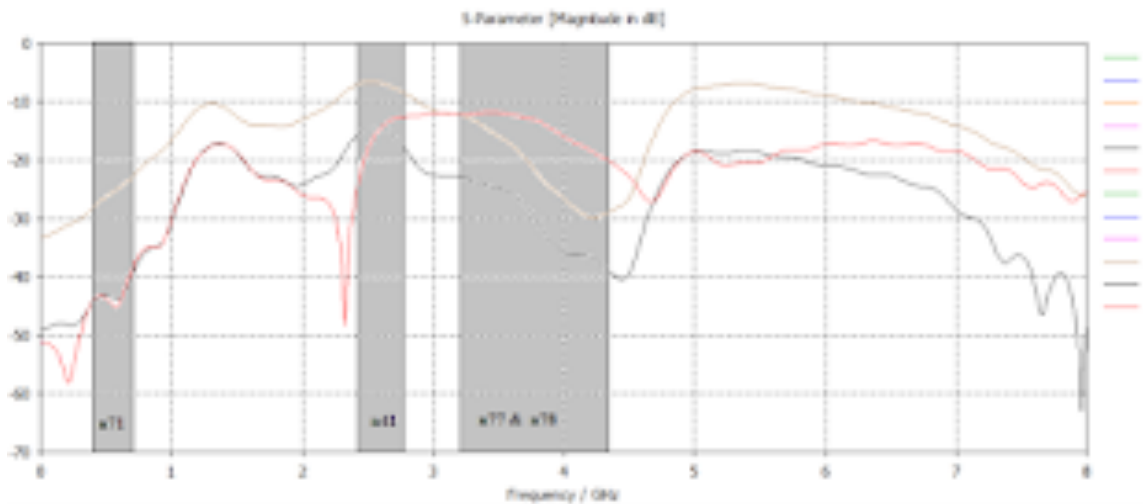

Frequency (MHz)	2579	3550	3750	600
-----------------	------	------	------	-----

Frequency (MHz)		2579	3550	3750	600
Avg. Isolation	Ports	<-20	<-25	<-29	<-40

3.11.4 Gains/Efficiencies/Polarizations

Bands	Gains (dBi)	Efficiencies	Polarizations
N41	3.2	>65%	Linear
N77/N78 3.5G Band	1.99	>77%	Linear
N77/N78 3.7G Band	2.75	>82%	Linear

3.11.5 Propagation Patterns

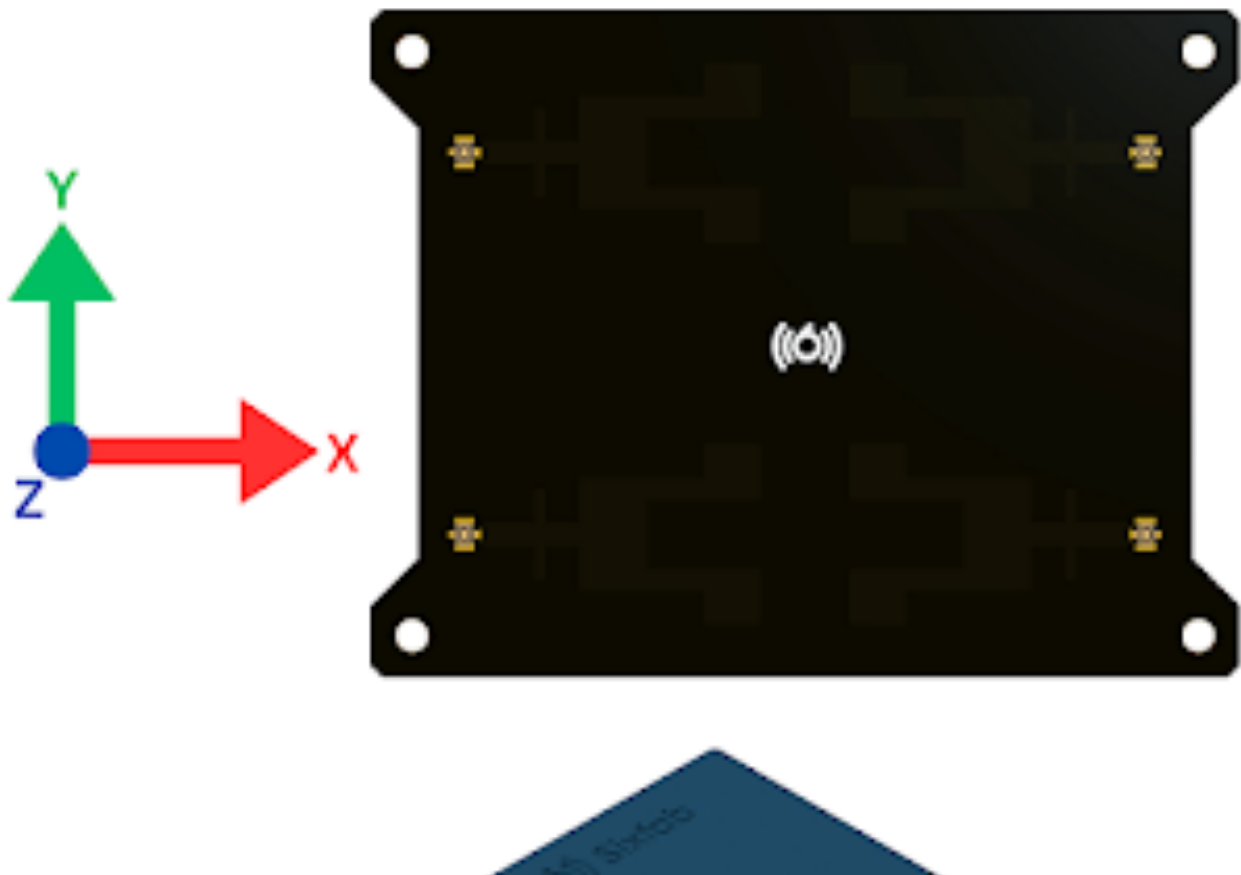

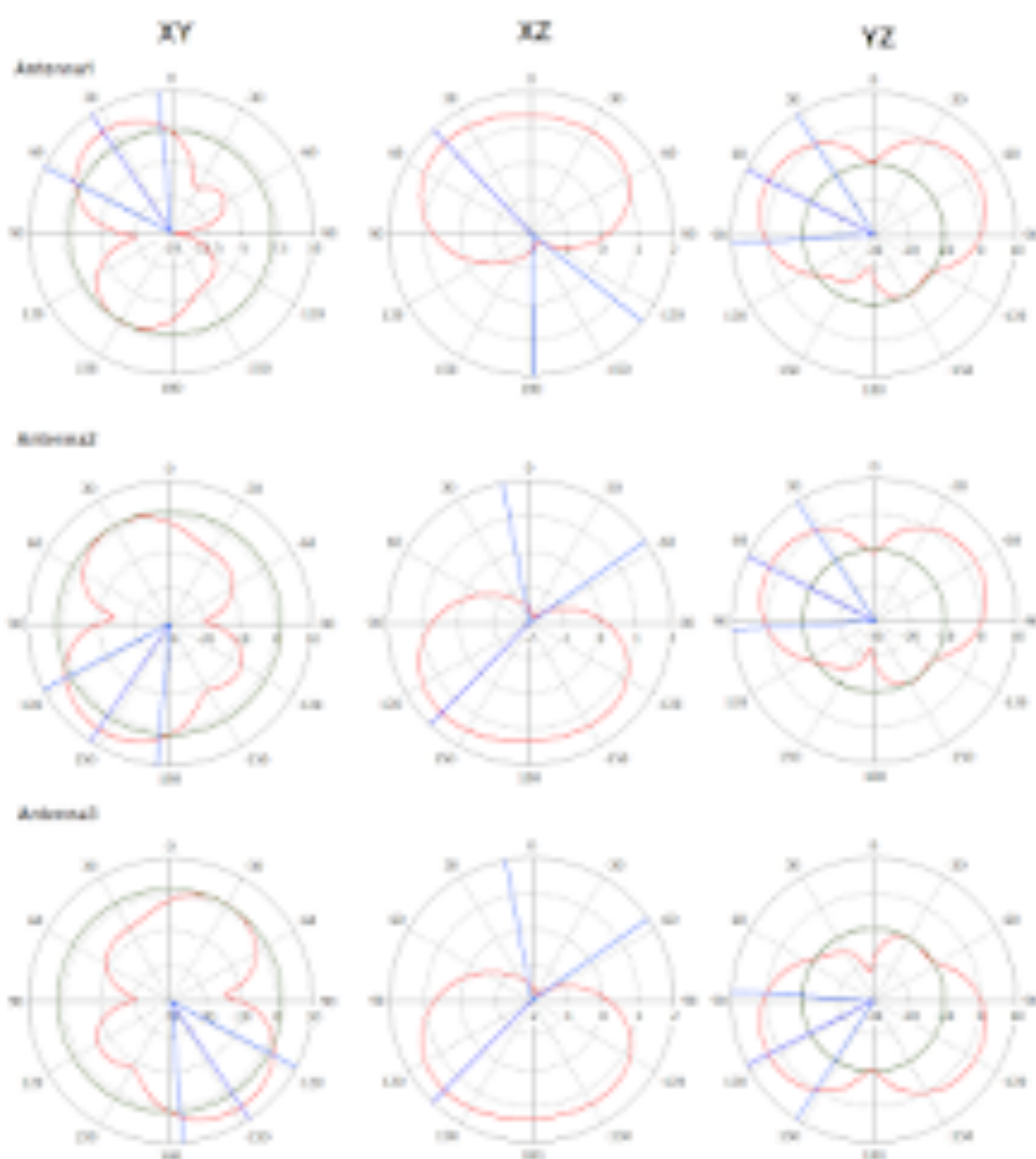
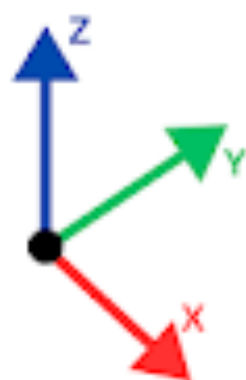

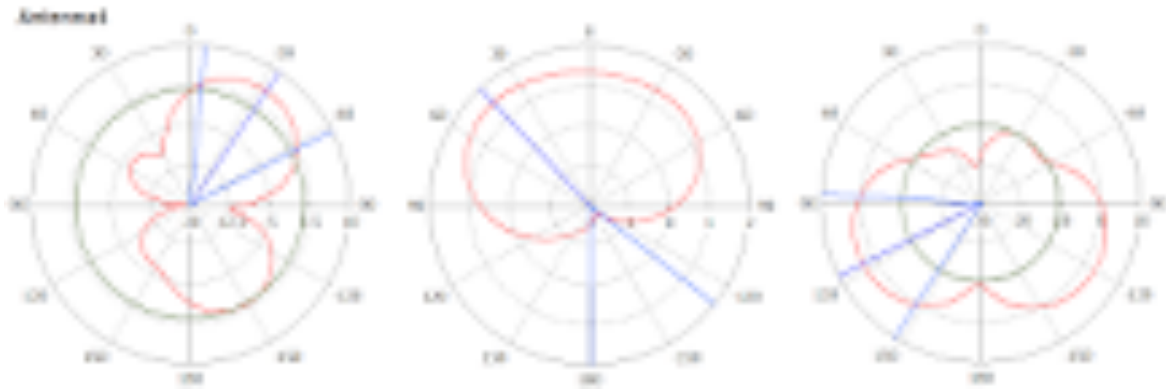

4. Software Specifications

4.1 Examples of different network configurations and how to set them up

5G networking modes are divided into NSA and SA. Taking the Quectel RM502Q-AE module as an example in the kit, it can be set for any of them or both.

The following AT command disables 5G NR.

4.1.1 AT+QNWPREFCFG="nr5g_disable_mode"

<p>Write Command <code>AT+QNWPREFCFG="nr5g_disable_mode"[,<disable_mode>]</code></p>	<p>Response If the optional parameter is omitted, query the current configuration: +QNWPREFCFG:"nr5g_disable_mode",<disable_mode> OK If the optional parameter is specified, disable 5G NR configuration: OK Or ERROR</p>
<p>Maximum Response Time</p>	<p>300 ms</p>
<p>Parameter</p>	<p><disable_mode> Integer type. Disable 5G NR SA/NSA 0 Neither is disable 1 Disable SA 2 Disable NSA</p>

4.1.2 AT+QNWPREFCFG="mode_pref" Network Search Mode Configuration

This command specifies the network search mode.

<p>Write Command AT+QNWPREFCFG="mode_pref"[, <mode_pref>]</p>	<p>Response If the optional parameter is omitted, query the current configuration: +QNWPREFCFG: "mode_pref", <mode_pref></p> <p>OK</p> <p>If the optional parameter is specified, configure the network search mode:</p> <p>OK</p> <p>Or</p> <p>ERROR</p>
<p>Maximum Response Time</p>	<p>300 ms</p>
<p>Parameter</p>	<p><mode_pref> String type. Use the colon as a separator to list the RATs to be configured. The parameter format is: RAT1:RAT2:... RATN. The RATs supported by the module are as follows:</p> <p>NR5G 5G NR only</p>

4.1.3 AT+CGDCONT Define PDP Contexts

The command specifies PDP context parameters for a specific context <cid>. A special form of the Write Command (AT+CGDCONT=<cid>) causes the values for context <cid> to become undefined. It is not allowed to change the definition of an already activated context.

This Read Command returns the current configurations for each defined PDP context.

<p>Test Command AT+CGDCONT=?</p>	<p>Response +CGDCONT: (range of supported <cid>s),<PDP_type>,<APN>,<PDP_addr>,(range of supported <data_comp>s),(range of supported <head_comp>s)I (list of supported</p>
--	---

Maximum Response Time	300 ms
	<p>Parameter</p> <p><cid> Integer type. PDP context identifier. A numeric parameter which specifies a particular PDP context definition. The parameter is local to the TE-MT interface and is used in other PDP context-related commands. The range of supported values (minimum value = 1) is returned by the test form of the command. Range: 1–42.</p> <p><PDP_type> String type. Packet data protocol type, a string parameter which specifies the type of packet data protocol. "IP" IPv4. Internet protocol (IETF STD 5) "PPP" Point to Point Protocol (IETF STD 51) "IPV6" Internet Protocol, version 6 (see RFC 2460) "IPV4V6" Virtual introduced to handle dual IP stack UE capability. (See 3GPP TS 24.301)</p> <p><APN> String type. Access point name, which is a logical name used to select the GGSN or the external packet data network. If the value is null or omitted, then the subscription value will be requested.</p> <p><PDP_addr> String type. Identify the MT in the address space applicable to the PDP. If the value is null or omitted, then a value may be provided by the TE during the PDP startup procedure or, failing that, a dynamic address will be requested. The allocated address may be read using the AT+CGPADDR.</p> <p><data_comp> Integer type. Controls PDP data compression (applicable for SNDCP only) (see 3GPP TS 44.065). 0 Off 1 On (Manufacturer preferred compression) 2 V.42bis 3 V.44 (Not supported currently)</p> <p><head_comp> Integer type. Control PDP header</p>

Integer type. Control PDP header compression (see 3GPP TS 44.065 and 3GPP TS 25.323).

- 0 Off
- 1 On
- 2 RFC1144
- 3 RFC2507
- 4 RFC3095

<IPv4_addr_alloc>

Integer type. Control how the MT/TA requests to get the IPv4 address information.

- 0** IPv4 address allocation through NAS signaling
- 1** IPv4 address allocated through DHCP

<request_type>

Integer type. Indicate the type of PDP context activation request for the PDP context.

- 0** PDP context is for new PDP context establishment or for handover from a non-3GPP access network (how the MT decides whether the PDP context is for new PDP context establishment or for handover is implementation specific).
- 1** PDP context is for emergency bearer services.

<P-SCF_discovery>

Integer type. Influence how the MT/TA requests to get the P-CSCF address, see 3GPP TS 24.229 annex B and annex L.

- 0** Preference of P-CSCF address discovery not influenced by AT+CGDCONT.
- 1** Preference of P-CSCF address discovery through NAS signaling.
- 2** Preference of P-CSCF address discovery through DHCP.

<IM_CN_Signalling_Flag_Ind>

Integer type. Indicate to the network whether the PDP context is for IM CN subsystem-related signaling only or not.

- 0** UE indicates that the PDP context is not for IM CN subsystem-related signaling only.
- 1** UE indicates that the PDP context is for IM CN subsystem-related signaling only.

<NSLPI> Integer type. Indicate the NAS signaling priority requested for this PDP context.

- 0** This PDP context is to be activated with the value for the low priority indicator

the value for the low priority indicator configured in the MT.

1 This PDP context is to be activated with the value for the low priority indicator set to "MS is not configured for NAS signaling low priority".

<securePCO>

Integer type. Specify if security protected transmission of PCO is requested or not (applicable for EPS only, see 3GPP TS 23.401 subclause 6.5.1.2).

0 Security protected transmission of PCO is not requested

1 Security protected transmission of PCO is requested

<IPv4_MTU_discovery>

Integer type. Influence how the MT/TA requests to get the IPv4 MTU size, see 3GPP TS 24.008 subclause 10.5.6.3.

0 Preference of IPv4 MTU size discovery not influenced by AT+CGDCONT

1 Preference of IPv4 MTU size discovery through NAS signaling

<local_addr_ind>

Integer type. Indicate to the network whether the MS supports local IP address in TFTs (see 3GPP TS 24.301 and 3GPP TS 24.008 subclause 10.5.6.3).

0 The MS does not support local IP address in TFTs

1 That the MS supports local IP address in TFTs

<Non-IP_MTU_discovery>

Integer type. Influence how the MT/TA requests to get the Non-IP MTU size, see 3GPP TS 24.008 subclause 10.5.6.3.

0 Preference of Non-IP MTU size discovery not influenced by AT+CGDCONT

1 Preference of Non-IP MTU size discovery through NAS signaling

<Reliable_Data_Service>

Integer type. Indicate whether the UE is using Reliable Data Service for a PDN connection or not, see 3GPP TS 24.301 and 3GPP TS 24.008 subclause 10.5.6.3.

0 Reliable Data Service is not being used for the PDN connection

1 Reliable Data Service is being used for the PDN connection

<SSC_mode>

Integer type. Indicate the session and service continuity (SSC) mode for the PDU

session in 5GS, see 3GPP TS 23.501.

0 The PDU session is associated with SSC mode 1

1 The PDU session is associated with SSC mode 2

2 The PDU session is associated with SSC mode 3

<S-NSSAI>

String type in hexadecimal character format. Dependent of the form, the string can be

separated by dot(s) and semicolon(s).

This parameter is associated with the PDU

session for identifying a network slice in 5GS, see 3GPP TS 23.501 and 3GPP TS 24.501. For the format and the encoding of S-NSSAI, see also 3GPP TS 23.003.

This

parameter shall not be subject to conventional character conversion as per AT+CSCS.

The parameter has one of the forms:

sst only slice/service type (SST) is present

sst;mapped_sst SST and mapped

configured SST are present

sst.sd SST and slice differentiator (SD) are present

sst.sd;mapped_sst SST, SD and mapped configured SST are present

sst.sd;mapped_sst.mapped_sd SST, SD, mapped configured SST and mapped

configured SD are present

<Pref_access_type>

Integer type. Indicate the preferred access type for the PDU session in 5GS, see 3GPP TS 23.501 and 3GPP TS 24.501.

0 The preferred access type is 3GPP access

1 The preferred access type is non-3GPP access

<RQos_ind>

Integer type. Indicate whether the UE supports reflective QoS for the PDU session,

see 3GPP TS 23.501 and 3GPP TS 24.501.

0 Reflective QoS is not supported for the

	<p>PDU session</p> <p>1 Reflective QoS is supported for the PDU session</p> <p><MH6-PDU> Integer type. Indicate whether the UE supports IPv6 multi-homing for the PDU session, see 3GPP TS 23.501 and 3GPP TS 24.501.</p> <p>0 IPv6 multi-homing is not supported for the PDU session</p> <p>1 IPv6 multi-homing is supported for the PDU session</p> <p><Always-on_req> Integer type. Indicate whether the UE requests to establish the PDU session as an always-on PDU session, see 3GPP TS 24.501.</p> <p>0 always-on PDU session is not requested</p> <p>1 always-on PDU session is requested</p>
--	---

4.2 Detailed network diagnostic and procedures to troubleshoot connection issues

4.2.1 AT+QENG Query Primary Serving Cell and Neighbour Cell Information

This command obtains the network information, such as primary serving cell and neighbour cells.

<p>Test Command</p> <p>AT+QENG=?</p>	<p>Response</p> <p>+QENG: (list of supported <cell_type>s)</p> <p>OK</p>
<p>Write Command</p> <p>Query the primary serving cell information</p> <p>AT+QENG="servingcell"</p>	<p>Response</p> <p>In SA mode:</p> <p>+QENG: "servingcell",<state>,"NR5G-SA",<duplex_mode>,<MCC>,<MNC>,<cellID>,<PCID>,<TAC>,<ARFCN>,<band>,<NR_DL_bandwidth>,<RSRP>,<RSRQ>,<SINR>,<scs>,<srlev></p> <p>OK</p> <p>In EN-DC mode:</p> <p>+QENG: "servingcell",<state></p> <p>+QENG: "LTE",<is_tdd>,<MCC>,<MNC>,<cellID>,<PCID>,<earfcn>,<freq_band_ind>,<UL_bandwidth>,<DL_bandwidth>.<TAC>.<RSRP>.</p>

<RSRQ>,<RSSI>,<SINR>,<CQI>,<tx_power>,<srxlev>+QENG: "NR5G-NSA",<MCC>,<MNC>,<PCID>,<RSRP>,<SINR>,<RSRQ>,<ARFCN>,<band>,<NR_DL_bandwidth>,<scs>

OK

In LTE mode:

+QENG: "servingcell",<state>,"LTE",<is_tdd>,<MCC>,<MNC>,<cellID>,<PCID>,<earfcn>,<freq_band_ind>,<UL_bandwidth>,<DL_bandwidth>,<TAC>,<RSRP>,<RSRQ>,<RSSI>,<SINR>,<CQI>,<tx_power>,<srxlev>

OK

In WCDMA mode:

+QENG: "servingcell",<state>,"WCDMA",<MCC>,<MNC>,<LAC>,<cellID>,<uarfcn>,<PSC>,<RAC>,<RSCP>,<ecio>,<phych>,<SF>,<slot>,<speech_code>,<comMod>

OK^[a]

Maximum Response Time

300 ms

Parameter

<cell_type>

String type. The information of different cells.

"servingcell" The information of 5G primary serving cells

<state>

String type. UE state.

"SEARCH" UE is searching but could not (yet) find a suitable 3G/4G/5G cell.

"LIMSRV" UE is camping on a cell but has not registered on the network.

"NOCONN" UE is camping on a cell and has registered on the network, and it is in idle mode.

"CONNECT" UE is camping on a cell and has registered on the network, and a call is in progress.

<duplex_mode>

String type. The 5G NR SA network mode.

"TDD"

"FDD"

<is_tdd>

String type. The LTE network mode.

String type. THE LTE NETWORK MODE.

"TDD"

"FDD"

<**MCC**>

16-bit unsigned integer. Mobile Country Code (first part of the PLMN code).

<**MNC**>

16-bit unsigned integer. Mobile Network Code (second part of the PLMN code).

<**ARFCN**>

Indicates the SA-ARFCN of the cell that was scanned.

<**band**>

32-bit unsigned integer. Frequency band of 5G NR SA network mode.

<**NR_DL_bandwidth**>

Integer type. Downlink bandwidth. (The value is only valid in RRC connected state.)

0 5 MHz

1 10 MHz

2 15 MHz

3 20 MHz

4 25 MHz

5 30 MHz

6 40 MHz

7 50 MHz

8 60 MHz

9 70 MHz

10 80 MHz

11 90 MHz

12 100 MHz

13 200 MHz

14 400 MHz

<**LAC**> Integer type. Location Area Code.

The parameter determines the two bytes location area code in hexadecimal format (e.g. 00C1 equals 193 in decimal) of the cell that was scanned. Range: 0–65535.

<**cellID**> Integer type. Cell ID. The parameter determines the 28-bit (UMTS and LTE)

or 36-bit (5G NR) cell ID. Range: 0–0xFFFFFFFF.

<**PCID**> Number format. Physical cell ID.

<**uarfcn**> The parameter determines the UTRA-ARFCN of the cell that was scanned.

<**earfcn**> The parameter determines the E-UTRA-ARFCN of the cell that was Scanned.

<**freq_band_ind**> Integer type. E-UTRA frequency band (see 3GPP 36.101).

<**UL_bandwidth**> Integer type. Uplink bandwidth.

- 0** 1.4 MHz
- 1** 3 MHz
- 2** 5 MHz
- 3** 10 MHz
- 4** 15 MHz
- 5** 20 MHz

<**DL_bandwidth**> Integer type. Downlink bandwidth.

- 0** 1.4 MHz
- 1** 3 MHz
- 2** 5 MHz
- 3** 10 MHz
- 4** 15 MHz
- 5** 20 MHz

<**TAC**> Tracking Area Code (see 3GPP 23.003 Section 19.4.2.3).

<**PSC**> The parameter determines the primary scrambling code of the cell that was scanned.

<**RAC**> Integer type. Routing Area Code. Range: 0–255.

<**RSCP**> The parameter determines the Received Signal Code Power level of the cell that was scanned.

<**ecio**> Carrier to noise ratio in dB = measured E_c/I_o value in dB.

<**RSRP**> 16-bit signed integer.

In LTE mode:

It indicates the signal of LTE Reference Signal Received Power (see 3GPP 36.214). Range: -140 to -44. Unit: dBm. The closer to -44, the better the signal is. The closer to -140, the worse the signal is.

In 5G NR mode:

It indicates the signal of 5G NR Reference Signal Received Power. Range: -140 to -44. Unit: dBm. The closer to -44,

the better the signal is. The closer to -140, the worse the signal is.

<RSRQ>

In LTE mode:

It indicates the signal of current LTE Reference Signal Received Quality (see 3GPP 36.214). Range: -20 to -3. Unit: dB. The closer to -3, the better the signal is. The closer to -20, the worse the signal is.

In 5G NR mode:

It indicates the signal of current 5G NR Reference Signal Received Quality. Range: -20 to -3. Unit: dB. The closer to -3, the better the signal is. The closer to -20, the worse the signal is.

<RSSI> LTE Received Signal Strength Indication.

<SINR>

In LTE mode:

It indicates LTE Signal-to-Interface plus Noise Ratio. The conversion formula for actual SINR is $Y = (1/5) \times X \times 10 - 20$ (X is the <SINR> value queried by AT+QENG and Y is the actual value of LTE SINR after calculating with the formula). Range: -20 to 30. Unit: dB.

In 5G NR mode:

It indicates the signal of 5G NR Signal-to-Interface plus Noise Ratio. Range: -20 to 30. Unit: dB.

<CQI>

Integer type. Channel Quality Indication. Range: 1–30.

<tx_power>

The value of transmission power in 1/10 dBm. It is the maximum value of transmission power of all Uplink channels. The <tx_power> value is only meaningful when the device is in traffic.

<phych>

Integer type. Physical channel.
0 DPCH
1 FDPCH

<SF>

Integer type. Spreading factor.

0 SF_4
1 SF_8

- 1 SF_8
- 2 SF_16
- 3 SF_32
- 4 SF_64
- 5 SF_128
- 6 SF_256
- 7 SF_512
- 8 UNKNOWN

<slot> Integer type.
0–16 Slot format for DPCH
0–9 Slot format for FDPCH

<speech_code> Destination number on which call is to be deflected.

<comMod> Integer type. Number format.
Compress mode.
0 Compress mode is not supported
1 Compress mode is supported

<srxqual>
Receiver automatic gain control on the camped frequency.

<ecno>
Integer type. Carrier to noise ratio in dB = measured E_c/I_o value in dB.

<set>
Integer type. 3G neighbor cell set.
1 Active set
2 Synchronous neighbor set
3 Asynchronous neighbor set

<rank>
Rank of this cell as neighbor for inter-RAT cell reselection.

<srxlev>
Suitable reception level for inter frequency cell. Unit: dB.

<threshX_low>
To be considered for re-selection. The suitable receive level value of an evaluated lower priority cell must be greater than this value.

<threshX_high>
To be considered for re-selection. The suitable receive level value of an evaluated higher priority cell must be greater than this value.

<thresh_Xhigh>
Reselection threshold for high priority layers.

	<p><thresh_Xlow> Reselection threshold for low priority layers.</p> <p><s_rxlev> Select reception level value for base station (see 3GPP 25.304). Unit: dB.</p> <p><cell_resel_priority> Integer type. Cell reselection priority. Range: 0–7.</p> <p><s_non_intra_search> Threshold to control non-intra frequency searches.</p> <p><thresh_serving_low> Specifies the suitable reception level threshold used by the UE on the serving cell when reselecting towards a lower priority RAT/frequency. Unit: dB.</p> <p><s_intra_search> Cell selection parameter for the intra frequency cell.</p> <p><scs> Integer type. NR sub-carrier space. 0 15 kHz 1 30 kHz 2 60 kHz 3 120 kHz 4 240 kHz</p>
--	---

4.2.2 AT+QNWINFO Query Network Information

This command queries network information such as access technology selected, the operator and the band selected.

Test Command AT+QNWINFO=?	Response OK
Execution Command AT+QNWINFO	Response +QNWINFO: <Act>,<oper>,<band>,<channel> [+QNWINFO: <Act>,<oper>,<band>,<channel>] OK
Maximum Response Time	300 ms
Parameter	<Act> String type. Access technology selected.

	<p>"NONE"</p> <p>"TDD NR5G" "FDD NR5G"</p> <p><oper> Operator names in numeric format.</p> <p><band> String type. Selected band. "NR5G BAND 41" "NR5G BAND 77" "NR5G BAND 78"</p> <p><channel> Integer type. Channel ID.</p>
--	--

4.2.3 AT+C5GREG 5GS Network Registration Status

This command queries the network registration status

Test Command AT+C5GREG=?	Response +C5GREG: (range of supported <n>s) OK
Read Command AT+C5GREG?	Response +C5GREG: <n>,<stat>[,<tac>],[<ci>], [<AcT>],[<Allowed _NSSAI_length>],[<Allowed_NSSAI>]] OK
Write Command AT+C5GREG=[<n>]	Response OK Or ERROR
Maximum Response Time	300 ms
Parameter	<p><n> Integer type. 0 Disable network registration unsolicited result code 1 Enable network registration unsolicited result code + C5GREG:<stat> 2 Enable network registration and location information unsolicited result code +C5GREG:<stat>[,<tac>],[<ci>],[<AcT>], [<Allowed_NSSAI_length>], [<Allowed_NSSAI>]]</p> <p><stat> Integer type. Indicate the NR registration status.</p>

0 Not registered, MT is not currently searching an operator to register to
1 Registered, home network
2 Not registered, but MT is currently trying to attach or searching an operator to register to
3 Registration denied
4 Unknown
5 Registered, roaming
8 Registered for emergency services only

<tac>

String type. Three-byte tracking area code in hexadecimal format.

<ci> String type. Five-byte (NR) cell ID in hexadecimal format.

<AcT> Integer type. Access technology selected.

10 E-UTRAN connected to a 5GCN

11 NR connected to a 5GCN

<Allowed_NSSAI_length> Integer type. Indicate the number of octets of the **<Allowed_NSSAI>** information element.

<Allowed_NSSAI> String type in hexadecimal format. Dependent of the form, the string can be separated by dot(s), semicolon(s) and colon(s). This parameter indicates the list of allowed S-NSSAIs received from the network. The **<Allowed_NSSAI>** is coded as a list of **<S-NSSAI>**s separated by colons. See **<S-NSSAI>** in subclause 10.1.1. This parameter shall not be subject to conventional character conversion as per **AT+CSCS**

4.2.4 AT+COPS Operator Selection

This command returns the current operators and their status, and allows automatic or manual network selection.

The Test Command returns a set of five parameters, each representing an operator presenting in the network. Any of the formats may be unavailable and should then be an empty field. The list of operators shall be in the order of: home network, networks referenced in (U)SIM and other networks.

The Read Command returns the current mode and the currently selected operator. If no operator is selected, **<format>**, **<oper>** and **<AcT>** are omitted.

The Write Command forces an attempt to select and register the GSM/UMTS/EPS/5G network operator. If the selected operator is not available, no other operator shall be selected (except **<mode>=4**). The format of selected operator name shall apply to further Read Commands (**AT+COPS?**).

<p>Test Command AT+COPS=?</p>	<p>Response +COPS: [(list of supported <stat>,long alphanumeric <oper>,short alphanumeric <oper>,numeric <oper>s[,<AcT>]s)[,,(range of supported <mode>s),(range of supported <format>s)]</p> <p>OK</p> <p>If there is any error related to MT functionality: +CME ERROR: <err></p>
<p>Read Command AT+COPS?</p>	<p>Response +COPS: <mode>[,<format>[,<oper>][,<AcT>]]</p> <p>OK</p> <p>If there is any error related to MT functionality: +CME ERROR: <err></p>

5. Compliance and Regulatory

5.1 Federal Communications Commission (FCC) regulations in the United States

According to the definition of mobile and fixed device is described in FCC requirement Part 2.1091(b), this device is a fix device. It certifies that the electromagnetic compatibility and interference from the device adheres to limits approved by the FCC that set applicable standards and testing measures in order to ensure that radio frequency emissions of the proposed device meet requirements such as the device not causing harmful interference and setting limitations on the amount of electromagnetic interference a device can generate.

Note: all the FCC standards tests reports and the final certification will be uploaded over the manufacturer grantee code of 2BAWK

List of applicable FCC rules FCC Part 15 Subpart B, Part 22, Part 24, Part 27, Part 90

5.2 Conformité Européene (CE) regulations in Europe and (UKCA) regulations in the United Kingdom

The device design fitted the statement's requirements of radio equipment directive 2014/53/EU(RED), which establishes a regulatory framework for placing radio equipment on the market. It ensures a single market for radio equipment by setting essential requirements for safety and health, electromagnetic compatibility, and the efficient use of the radio spectrum. It also provides the basis for further regulation governing some additional aspects. These include technical features for the protection of privacy, personal data and against fraud. Furthermore, additional aspects cover interoperability, access to emergency services, and compliance regarding the combination of radio equipment and software.

5.3 Industry Canada (IC) regulations in Canada

This device complies with Industry Canada's license-exempt RSSs. Operation is subject to the following two conditions: (1) This device does not cause interference; and (2) This device accept any interference, including interference that may cause undesired operation of the device." or "Le présent appareil est conforme aux CNR d'Industrie Canada applicables aux appareils radio exempts de licence.

Furthermore, the IC standards (RSS 130 RSS 132 RSS 133 RSS 139 RSS 199 ICES-003) will be applied to check the device reliability to achieve the IC requirements.

5.4 International Electro technical Commission (IEC) standards for safety and EMC CB

The device designed to be compatible with IEC CB scheme Standard tests*.

* still under certification process

5.5 PCS Type Certification Review Board (PTCRB) standards for cellular devices

To ensure compliance with cellular network standards within the PTCRB Operators' networks, the PTCRB certification tests started and will be gotten in the third quarter of 2023.

5.6 Global Certification Forum (GCF) standards for cellular devices

To ensure compliance with verifies global interoperability between the proposed device and other devices with embedded wireless modules, and mobile networks., the GCF certification tests started and will be gotten in the third quarter of 2023.

6. Warranty and Liability Disclaimers

6.1 Description of the warranty provided with the product

Sixfab, Inc. warrants to the original purchaser that Sixfab Jumpstart 5G will be free from defects in materials and workmanship for a period of one hundred eighty (180) days from the date of purchase. If a defect is found during the warranty period, Sixfab, Inc. will, at its option, repair or replace the defective product.

6.2 Warranty period and limitations

This warranty does not cover damage caused by:

- Accident, misuse, or abuse
- Improper installation or use

- Contact with liquid or other foreign substances
- Lightning or other acts of nature
- Exposing the kit to direct sunlight

This warranty is void if the product is modified with soldering/desoldering/reworking components, changing any component, changing/removing thermal elements or repaired by anyone other than Sixfab, Inc. or its authorized representatives.

6.3 Disclaimer of liability for damages resulting from the use of the product

Sixfab, Inc. shall not be liable for any incidental, consequential, or special damages arising out of or in connection with the use or performance of Sixfab Jumpstart 5G, even if Sixfab, Inc. has been advised of the possibility of such damages.

6.4 Limitations on liability for damages caused by defects in the product

The maximum liability of Sixfab, Inc. for any damages arising out of or in connection with Sixfab Jumpstart 5G, whether in contract, tort, or otherwise, shall be limited to the purchase price of the product.

Additional Disclaimers

- Sixfab, Inc. makes no warranty or representation regarding the accuracy or completeness of any information or documentation provided with Sixfab Jumpstart 5G. Documentations are updated regularly and offline versions might be outdated.
- Sixfab, Inc. shall not be liable for any damages arising out of or in connection with the use of any third-party software or hardware with Sixfab Jumpstart 5G.
- Sixfab, Inc. shall not be liable for any damages arising out of or in connection with the use of Sixfab Jumpstart 5G for any illegal or unauthorized purpose.

Environmental Damage

Sixfab Jumpstart 5G may contain hazardous materials. It is the responsibility of the user to dispose of Sixfab Jumpstart 5G in accordance with all applicable environmental regulations.

Third-Party Losses

Sixfab, Inc. shall not be liable for any damages arising out of or in connection with the use of Sixfab Jumpstart 5G that cause loss to any third party.

Indemnification

The user agrees to indemnify and hold Sixfab, Inc. harmless from and against any and all claims, losses, damages, liabilities, costs, and expenses (including reasonable attorneys' fees) arising out of or in connection with the user's use of Sixfab Jumpstart 5G.

Governing Law

This warranty and all disputes arising out of or in connection with it shall be governed by and construed in accordance with the laws of the State of California, without regard to its conflict of laws provisions.

Reference Documents

- [Quectel RM502Q-AE 5G Specification V1.2](#)
- [Quectel RG50xQ-RM5xxQ Series AT Commands Manual V1.2](#)
- [Quectel RG50xQ-RM5xxQ Series 5G Network Searching Scheme Introduction V1.0](#)
- [Quectel RG50xQ-RM5xxQ Series 5G Network Status Judgement Introduction V1.0](#)
- [Quectel RM50xQ Series Reference Design V1.3](#)
- [Quectel RM50xQ Series Hardware Design V1.2](#)
- [Quectel RG50xQ-RM5xxQ Series FTM Application Note V1.0](#)

- [Quectel RG50xQ-RM5xxQ Series GNSS Application Note V1.1](#)
 - [Quectel RG50xQ RM5xxQ Series DFOTA Application Note V1.0](#)
 - [Quectel RG50xQ-RM5xxQ Series Software Thermal Management Guide V1.0](#)
 - [Quectel RG50xQ-RM5xxQ Series Secure Boot Application Note V1.0](#)
 - [Quectel RM50xQ Series Thermal Design Guide V1.0](#)
 - [Quectel RM502Q-AE 3D Dimensions V1.1](#)
-

FCC Statement

This device complies with part 15 of the FCC rules. Operation is subject to the following two conditions: (1) this device may not cause harmful interference, and (2) this device must accept any interference received, including interference that may cause undesired operation.

Caution: Changes or modifications not expressly approved by the party responsible for

compliance could void the user's authority to operate the equipment.

NOTE: This equipment has been tested and found to comply with the limits for a Class

B digital device, pursuant to part 15 of the FCC Rules. These limits are designed to provide reasonable protection against harmful interference in a residential installation. This equipment generates uses and can radiate radio frequency energy and, if not installed and used in accordance with the instructions, may cause harmful interference

to radio communications. However, there is no guarantee that interference will not occur in a particular installation. If this equipment does cause harmful interference to radio or television reception, which can be determined by turning the equipment off and on, the user is encouraged to try to correct the interference by one or more of the following measures:

- Reorient or relocate the receiving antenna.
- Increase the separation between the equipment and receiver.
- Connect the equipment into an outlet on a circuit different from that to which the receiver is connected.
- Consult the dealer or an experienced radio/TV technician for help important announcement

Radiation Exposure Statement

To comply with FCC RF exposure compliance requirements, this grant is applicable to only mobile configurations. The antennas used for this transmitter must be installed to provide a separation distance of at least 20 cm from all persons and must not be co-located or operating in conjunction with any other antenna or transmitter.

ISED Statement

- English: This device complies with Industry Canada license - exempt RSS standard(s). Operation is subject to the following two conditions: (1) This device may not cause interference, and (2) This device must accept any interference, including interference that may cause undesired operation of the device. The digital apparatus complies with Canadian CAN ICES - 003 (B)/NMB - 3(B).

- French: Le présent appareil est conforme aux CNR d'Industrie Canada applicables aux appareils radio exempts de licence. L'exploitation est autorisée aux deux conditions suivantes: (1) l'appareil ne doit pas produire de brouillage, et (2) l'utilisateur de l'appareil doit accepter tout brouillage radioélectrique subi, même si le brouillage est susceptible d'en compromettre le fonctionnement.

L'appareil numérique est conforme à la canadienne CAN ICES - 003 (B)/NMB - 3(B).

Radiation Exposure Statement

To comply with FCC RF exposure compliance requirements, this grant is applicable to only mobile configurations. The antennas used for this transmitter must be installed to provide a separation distance of at least 20 cm from all persons and must not be co-located or operating in conjunction with any other antenna or transmitter.

Pour se conformer aux exigences de conformité d'exposition RF de la FCC, cette subvention est applicable uniquement aux configurations mobiles. Les antennes utilisées pour cet émetteur doivent être installées de manière à fournir une distance de séparation d'au moins 20 cm de toutes les personnes et ne doivent pas être colocalisées ou fonctionner conjointement avec toute autre antenne ou émetteur.