

承認書

SPECIFICATION FOR APPROVAL

客戶: CUSTOMER:	澳德鴻
客戶料號: CUST P/N:	
泛亞料號: FINE P/N:	
產品型號: DESC:	φ20.5x43-10Ts-0.08x105-50mm-50C
日期: DATE:	2018/01/20
版本: Version:	A.0

擬制 PREPARED BY	審核 CHECKED BY	批准 APPROVED BY	客戶承認 CUSTOMER APPROVE
郭洋洋	蔡紀雨	倪星	

泛亞電子實業（HK）有限公司

FINE ELECTRONICS INDUSTRIAL (HK) LIMITED

工廠地址：東莞市石碣鎮四甲工業區

TEL: 0769-22490287 / 22452492

FAX: 0769-22499451

E-mail: fineelec@163.com

SPECIFICATION

產品型號: DESC	φ20.5x43-10Ts-0.08x105-50mm-50C	版本 Rev: A.0	客戶 CUST:	澳德鴻
			泛亞料号 Fine P/N:	
			客戶料号 CUST P/N:	

一、尺寸 DIMENSION:(mm)

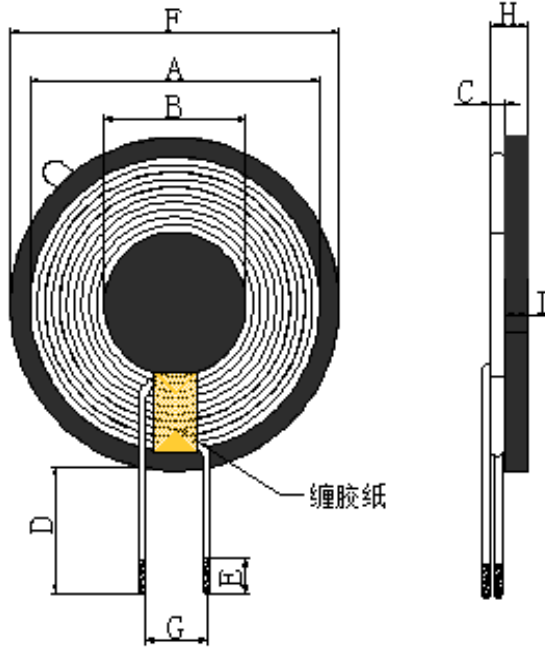

A	43±1.5
B	20.5±0.5
C	1.2±0.2
D	50±3
E	2-5
F	30±1
G	8.0 ref
H	3.2max
I	1.0±0.2

Note:
 1. Cross outlet;
 2. The coil is attached to a circular hard disk, the disk size is 50±1mm, and the thickness is 1.0±0.2mm.;
 3. Coil with 8mm wide high temperature adhesive paper; 4. Tape the back of the magnetic disc with hand-torn double-sided tape;

二、原理图 SCHEMATIC DIAGRAM:



三、绕线参数 Winding Specification:

序号 NO.	端子 TERMINAL		线径 WIRE	圈数 Turns	绕线方向 Winding Direction
1	S	F	silk-covered wire 0.08*105P	10Ts	CCW

四、电气特性 ELECTRICAL CHARACTERISTICS:

温度 TEMPERATURE:25±10°C, 湿度 RELATIVE HUMIDITY:65±20%

序号 NO.	项目 ITEM	端子 TERMINAL	标准 SPECIFICATION	测试条件 TEST FREQUENCY	测试仪器 TEST EQUIPMENTS
1	IND.	S-F	3.8uH ±30% 单独线圈	100KHz/1.0V	LCZ METER 1062B
2	IND.	S-F	6.5uH ±10% 加磁片	100KHz/1.0V	LCZ METER 1062B
3	DCR	S-F			

擬制/日期 PREPARED BY/DATE	審核/日期 CHECKED BY/DATE
郭洋洋 2018/01/20	蔡紀雨 2018/01/20