

RF EVALUATION TEST REPORT

Applicant : Alliance Sports Group., LP

Address : 700 Henrietta Creek Rd. Roanoke, TX 76262 the USA.

Manufacturer : Dongguan Zhongkang Technology Electronics Co., Ltd.

Address : No.12 Yansha Road, TianXin, Tangxia Town, Dongguan City, Guangdong
Province, China

Factory : Dongguan Zhongkang Technology Electronics Co., Ltd.

Address : No.12 Yansha Road, TianXin, Tangxia Town, Dongguan City, Guangdong
Province, China

Product Name..... : NEBO Rambler 100W Power Station

Brand Name :  , 

Model No. : NEB-PST-0004

FCC ID..... : 2BASY-NEBOPS100

Measurement Standard..... : 47 CFR PART 2, Section 2.1093
TCB Workshop, April 27, 2022, Wireless Power Transfer Updates

Receipt Date of Samples..... : March 09, 2023

Date of Tested..... : March 09, 2023 to Jun 26, 2023

Date of Report..... : Jun 26, 2023

This report shows that above equipment is technically compliant with the requirements of the standards above. All test results in this report apply only to the tested sample(s). Without prior written approval of Dongguan Nore Testing Center Co., Ltd, this report shall not be reproduced except in full.



Prepared by

Rose Hu / Project Engineer



Approved by

Iori Fan / Authorized Signatory



Table of Contents

1. General Description of EUT.....	4
2. Test Facility and Location	6
3. Test Modes Detail.....	6
4. Configuration of EUT	7
5. Modification of EUT	7
6. Description of Support Device	7
7. Deviations and Abnormalities from Standard Conditions.....	7
8. Applicable Standards and References	8
9. Equipment approval considerations.....	8
10. Measurement Uncertainty	9
11. Maximum Permissible Exposure	10
12. Test Equipment List.....	18
13. Test Photos	19

Revision History

Report Number	Description	Issued Date
NTC2303123F01	Initial Issue	2023-06-26

1. General Description of EUT

Product Information	
Product Name:	NEBO Rambler 100W Power Station
Main Model Name:	NEB-PST-0004
Additional Model Name:	N/A
Model Difference:	N/A
S/N:	2303-1207
Brand Name:	 
Hardware Version:	V01
Software Version:	V01
Rating:	Input: USB-C: DC 5V 3A; DC 9V 3A; DC 12V 3A; DC 15V 3A or DC 20V 2.25A; DC input: DC 12V-24V 50W; Output: 2 x USB DC 5V 2.4A; USB-C: DC5V 3A; DC 9V 3A; DC 12V 3A; DC 15V 3A or DC 20V 2.25A Wireless charging: 10W, AC 115V 60Hz 100W AC Input: AC 100-240V 50/60Hz come from Adapter Capacity: 94900mWh, 18.25V
Typical Arrangement:	Table-top
I/O Port:	Refer to user manual
Accessories Information	
Adapter:	Model: S6-QC20-ETL Input: AC 100-240V, 50/60Hz, 0.6A Output: DC 5V 3A/ DC 9V 2.22A/ DC 12V 1.67A
Cable:	USB line: 0.58m, unshielded, detachable Car charger line: 1.17m, unshielded, undetachable
Other:	N/A
Additional Information	
Note:	This report only applies to wireless charging function.
Remark:	All the information above are provided by the manufacturer. More detailed feature of the EUT please refers to the user manual.

Technical Specification	
Frequency Range:	110.5-205KHz
Modulation Type:	FSK
Antenna Type:	Coil antenna
Output power for each coil:	10W, 7.5W, 5W
Remark:	The information above are provided by the manufacturer. More detailed feature of the EUT please refers to the user manual.

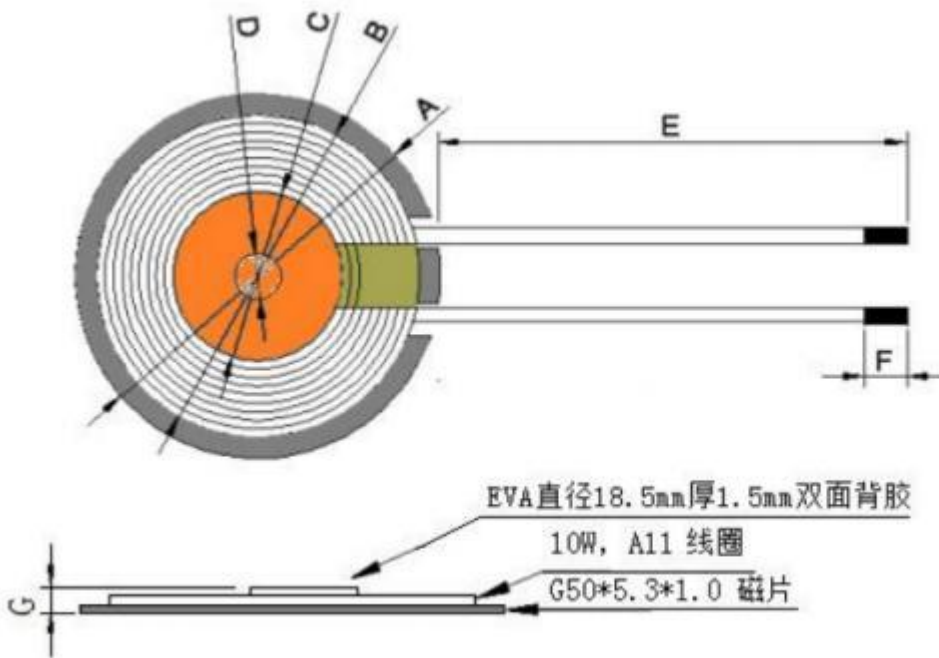

A	49.5±0.5
B	42.0±1.0
C	20.5±1.0
D	5.3±0.2
E	26±2
F	3.5±1.5
G	3.0Max

2. Test Facility and Location

Test Site	:	Dongguan Nore Testing Center Co., Ltd. (Dongguan NTC Co., Ltd.)
Accreditations and Authorizations	:	<p>The Laboratory has been assessed and proved to be in compliance with CNAS/CL01 Listed by CNAS, August 13, 2018 The Certificate Registration Number is L5795. The Certificate is valid until August 13, 2024</p> <p>The Laboratory has been assessed and proved to be in compliance with ISO17025 Listed by A2LA, November 01, 2017 The Certificate Registration Number is 4429.01</p> <p>Listed by FCC, November 06, 2017 Test Firm Registration Number: 907417</p> <p>Listed by Industry Canada, June 08, 2017 The Certificate Registration Number. Is 46405-9743A</p>
Test Site Location	:	Building D, Gaosheng Science and Technology Park, Hongtu Road, Nancheng District, Dongguan City, Guangdong Province, China

3. Test Modes Detail

Test Mode	Test Setup Configuration	Remark
1.	wireless charging (5W)	Internal Li-ion battery with full status
2.	wireless charging (7.5W)	Internal Li-ion battery with full status
3.	wireless charging (10W)	Internal Li-ion battery with full status

Note: The tests took into account the state of the phone's battery at 1%, 50%, and 99%, only the worst case records in the report.

Note: Both the internal li-ion battery and external AC/DC adapter power modes are considered, and only the worst case was recorded in the report.

4. Configuration of EUT

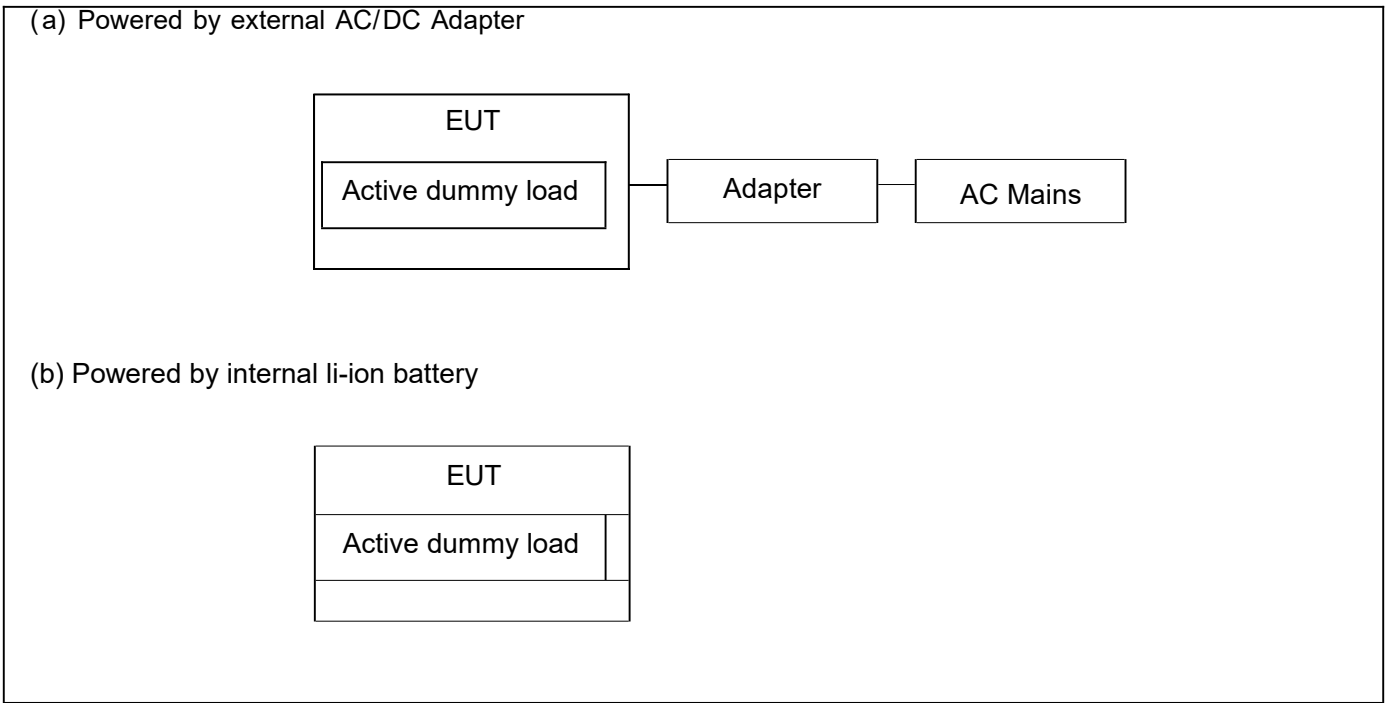

5. Modification of EUT

No modifications are made to the EUT during all test items.

6. Description of Support Device

The EUT has been tested as an independent unit together with other necessary accessories or support units. The following support units or accessories were used to form a representative test configuration during the tests.

No.	Equipment	Brand	M/N	S/N	Cable Specification	Remarks
1.	Active Dummy Load	EESON	5/7.5/10W	N/A	---	Provided by the lab

7. Deviations and Abnormalities from Standard Conditions

No additions, deviations and exclusions from the standard.

8. Applicable Standards and References

According to the specifications of the manufacturer, the EUT must comply with the requirements of the following standards:

Test Standards:

47 CFR Part 1, 1.1307(b) and 1.1310

KDB 680106 D01v03

TCB Workshop April 2022

9. Equipment approval considerations

No.	Requirements	Conditions of the EUT
1.	Power transfer frequency is less than 1MHz	Yes, the operated frequency range is 110.5-205KHz.
2.	Output power from each primary coil is less than or equal to 15 watts	Yes, the maximum output power of the primary coil is 10W
3.	The system may consist of more than one source primary coils, charging one or more clients. If more than one primary coil is present, the coil pairs may be powered on at the same time	Yes; the transfer system includes two source primary coils pairs that can be powered on at the same time.
4.	Client device is placed directly in contact with the transmitter.	Yes, Client device is placed directly in contact with the transmitter.
5.	Mobile exposure conditions only (portable exposure conditions are not covered by this exclusion).	No, the device can be used as portable exposure condition.
6.	The aggregate H-field strengths at 20 cm surrounding the device from all simultaneous transmitting coils are demonstrated to be less than 50% of the MPE limit.	Yes, less than the limits.
7.	The H-field strength surrounding the device is below the applicable limit in 47CF 1.1310.	Yes, H-field strength results are all below the limit in 47CF 1.1310.
8.	H-field data are taken along all three axes the device, from 0cm to 20 cm, in 2cm minimum increment measured from the edge of the device, with one axis coincident with the axis of the main coil	Yes, all testing distance required and axis of the device have been measured from the edge of the device; details please refer to the test results;
Remark: <input checked="" type="checkbox"/> need PAG process <input type="checkbox"/> no need PAG process		

10. Measurement Uncertainty and Duty Cycle

No.	Test Item	Uncertainty	Remarks
1.	Magnetic Field Emissions	±0.15 dB	---
2.	Electric Field Emissions	±0.36 dB	---

Note: This uncertainty represents an expanded uncertainty expressed at approximately the 95% confidence level using a coverage factor of k=2.

Duty Cycle and Measurement methods

Test Limit

None; for reporting purposes only.

Test Procedure

Zero-Span Spectrum Analyzer Method.

Test Setup Layout



Test Result and Data

During the test, the duty cycle ≥ 98%

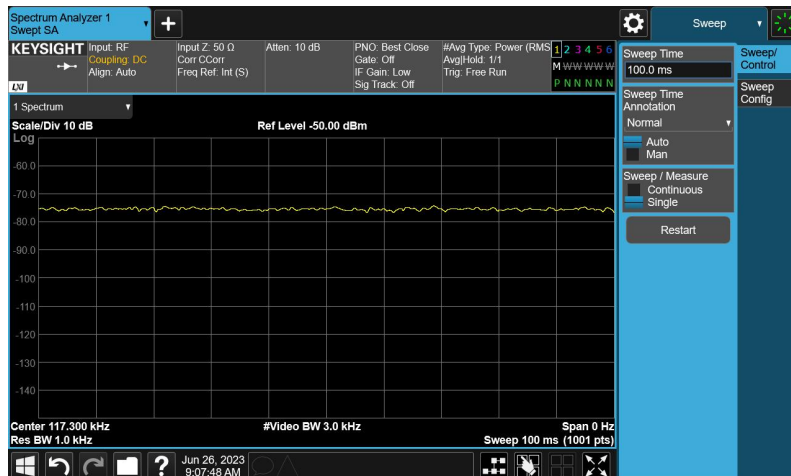

11. Maximum Permissible Exposure

LIMIT

Frequency range (MHz)	Electric field strength (V/m)	Magnetic field strength (A/m)	Power density (mW/cm ²)	Averaging time (minutes)
(A) Limits for Occupational/Controlled Exposures				
0.3-3.0	614	1.63	*(100)	6
3.0-30	1842/f	4.89/f	*(900/f ²)	6
30-300	61.4	0.163	1.0	6
300-1500	/	/	f/300	6
1500-100,000	/	/	5	6
(B) Limits for General Population/Uncontrolled Exposure				
0.3-1.34	614	1.63	*(100)	30
1.34-30	824/f	2.19/f	*(180/f ²)	30
30-300	27.5	0.073	0.2	30
300-1500	/	/	f/1500	30
1500-100,00	/	/	1.0	30

F=frequency in MHz

*=Plane-wave equivalent power density

RF exposure compliance will need to be determined with respect to 1.1307(c) and (d) of the FCC rules. The emissions should be within the limits at 300kHz in Table 1 of 1.1310(use the 300kHz limits for 150kHz: 614V/m,1.63A/m).

Per KDB 680106 D01 v03 r01, RF exposure evaluation at 15cm surrounding the device and 20cm above the top surface. Emission between 50 kHz to 300 kHz should be assessed versus the limits at 300 kHz in Table 1 of Section 1.1310: 1.63/Am and aggregate H-field strengths from all simultaneous transmitting coils are demonstrated to be less than 50% of the MPE limit.

BLOCK DIAGRAM OF TEST SETUP

For Mobile:

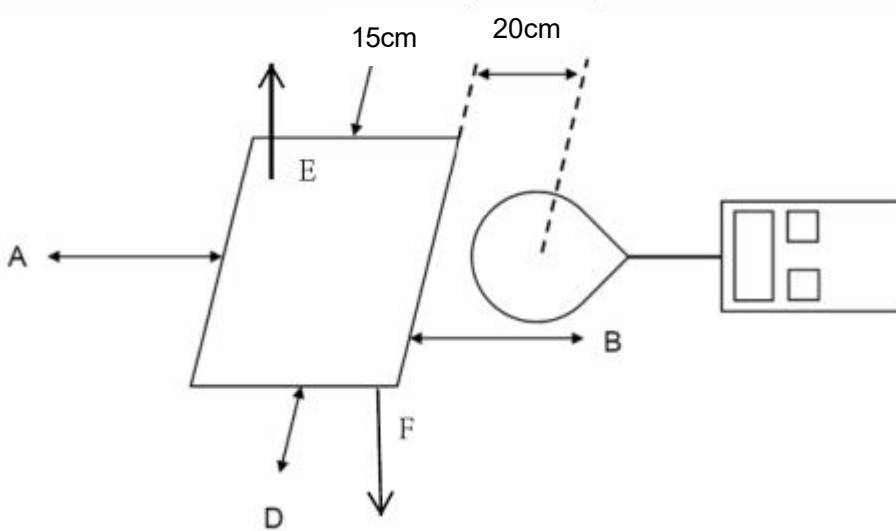

Note: The distance of the points A/B/C/D is 15cm, and the point E is 20cm.

For Portable:

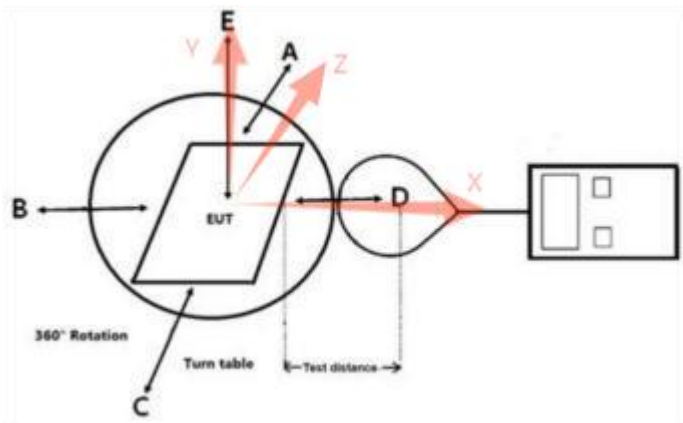

Note: The distance of the points A/B/C/D/E/F is 2,4,6,8,10,12,14,16,18, 20cm.

The values tested by the probe are X, Y, and Z on three axes perpendicular to the edge of the device.

Top and bottom side coincident with the axis(Y) of the main coil.

Perform H-field/E-field measurements are taken along all three axes the device from 0cm~20cm in 2cm minimum increment for each edge surface of the host/client pair. If the center of the probe sensing element is more than 6mm from the probe outer edge, the field strengths need to be estimated for the positions that are not reachable.

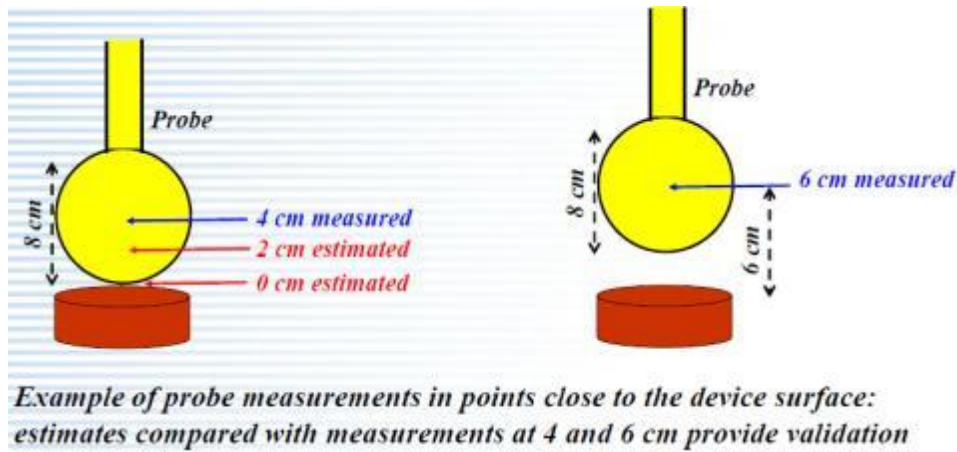

According to Calibration information and specification about ETL-400 Probe, The Probe ETL-400 Probe’s sensitive elements center is located in the probe’s center, and the dimensions is 12.5x12.5mm. so the actual 0cm, 2cm, 4cm and 6cm field strengths need to be estimated for the positions that are not reachable. The Extrapolated Value Calculation Method please see below) . And the result of test distance 8cm~20cm was measured value.

Probe	Length	Width	Radius
	12.5cm	12.5cm	6.25cm

Note: Device is a coil emitting structure, just need to evaluated H-field.

Top & Bottom Side:

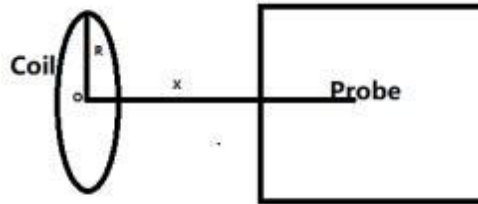

$$B = \frac{\mu_0 * I * N * R^2}{2 * (R^2 + x^2)^{3/2}}$$

B: means H-field value;

μ₀: is space permeability; μ₀=4π*10⁻⁷;

I : A current element passing through a coil;

R: The distance from the center point of the wireless charging device to other edges

x: means the evaluated point to the coil center. (For top & bottom side: x=test distance; For other side: x=test distance+R)

N: Number of turns, According to provided “Antenna specification” files: N=10.
(During the estimation process, remove the energy lost due to charging)

μ₀=0.0000012566

R, A=0.06m, B=0.0975m, C=0.06m, D=0.0975m, E (Top side) =0.001m, F (Bottom side)=0.043m

X= E, F= test distance 0CM 2CM 4CM 6CM For E, +0.1CM For F, +4.3CM

Top side(The results are selected after two decimal places)

X=0	B=0.71
X=2	B=0.68
X=4	B=0.65
X=6	B=0.43

Bottom side(The results are selected after two decimal places)

X=0	B=0.61
X=2	B=0.58
X=4	B=0.55
X=6	B=0.37

Front, left, right & rear Side:

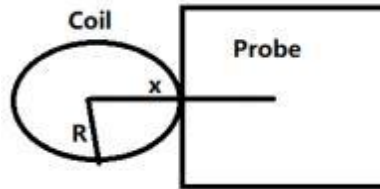

$$B = \frac{\mu_0 * I * N}{2 * x}$$

- B:** means H-field value;
- μ_0 : is space permeability; $\mu_0=4\pi*10^{-7}$;
- I** : A current element passing through a coil;
- R:** The distance from the center point of the wireless charging device to other edges
- x:** means the evaluated point to the coil center. (For top & bottom side: x =test distance; For other side: x =test distance+ R)
- N:** Number of turns, According to provided "Antenna specification" files: $N=10$.
(During the estimation process, remove the energy lost due to charging)

U0=0.0000012566

R, A=0.06M, B=0.0975CM, C=0.06CM, D=0.0975CM, E TOP side =0.001CM, F BOTTOM side=0.043CM
X= E, F= test distance 0CM 2CM 4CM For A, +6CM For B, +9.75CM

A side(The results are selected after two decimal places)

X=0	B=0.52
X=2	B=0.40
X=4	B=0.33
X=6	B=0.27

B side(The results are selected after two decimal places)

X=0	B=0.36
X=2	B=0.30
X=4	B=0.25
X=6	B=0.22

C side(The results are selected after two decimal places)

X=0	B=0.44
X=2	B=0.34
X=4	B=0.28
X=6	B=0.24

D side(The results are selected after two decimal places)

X=0	B=0.31
X=2	B=0.26
X=4	B=0.22
X=6	B=0.19

For validation purposes: If the value to show a 30% agreement between the mode and the (E- and/or H-field) probe measurements for the two closest points to the device surface, and with 2cm increments. Then this extrapolation method is reasonable.

Note: The percent ratio of agreement is the difference between the estimated and measured values divided by the average of the estimated and measured values.

Estimated value

	A side	B side	C side	D side	Top side	Bottom side
8 cm	0.20	0.17	0.20	0.17	0.33	0.28
10cm	0.18	0.15	0.18	0.15	0.26	0.22

Practical testing value

	A side	B side	C side	D side	Top side	Bottom side
8 cm	0.19	0.19	0.20	0.19	0.36	0.30
10cm	0.19	0.19	0.19	0.18	0.25	0.19

8cm Agreement ratio

Estimated	0.20	0.17	0.20	0.17	0.33	0.28
Practical	0.19	0.19	0.20	0.19	0.36	0.30
Result	6.81%	-11.69%	-00.00%	-11.69%	-10.22%	-8.70%

10cm Agreement ratio

Estimated	0.18	0.15	0.18	0.15	0.26	0.22
Practical	0.19	0.19	0.19	0.18	0.25	0.19
Result	-5.90%	-22.29%	-5.90%	-16.93%	3.92%	14.63%

TEST PROCEDURES

For mobile exposure conditions:

- a. The RF exposure test was performed in anechoic chamber;
- b. E and H-field measurements should be made with the center of the probe at a distance of 15cm surrounding the EUT and 20cm above the top surface of the primary/client pair.
- c. The highest emission level was recorded and compared with limit.
- d. The EUT was measured according to the dictates of KDB 680106 v03r01.

For portable exposure conditions:

- a. The RF exposure test was performed in anechoic chamber;
- b. E and H-field measurements should be made with the probe at 0cm for all side of the EUT.
- c. The highest emission level was recorded and compared with limit.

For portable exposure conditions:

Perform H-field measurements for each edge/top surface of the host/client pair at every 2cm, starting from as close as possible out to 20cm.

TEST RESULTS

PASS

Please refer to the following pages of the worst case (10W wireless charging & powered by external AC/DC Adapter).

Test Distance (cm)	Test Position	Probe Measure Result (A/m)	Limit (A/m)
0	Side A	0.52 (Estimate)	0.815
	Side B	0.36 (Estimate)	0.815
	Side C	0.44 (Estimate)	0.815
	Side D	0.31 (Estimate)	0.815
	Side E	0.71 (Estimate)	0.815
	Side F	0.61 (Estimate)	0.815
2	Side A	0.40 (Estimate)	0.815
	Side B	0.30 (Estimate)	0.815
	Side C	0.34 (Estimate)	0.815
	Side D	0.26 (Estimate)	0.815
	Side E	0.68 (Estimate)	0.815
	Side F	0.58 (Estimate)	0.815
4	Side A	0.33 (Estimate)	0.815
	Side B	0.25 (Estimate)	0.815
	Side C	0.28 (Estimate)	0.815
	Side D	0.22 (Estimate)	0.815
	Side E	0.65 (Estimate)	0.815
	Side F	0.55 (Estimate)	0.815
6	Side A	0.27 (Estimate)	0.815
	Side B	0.22 (Estimate)	0.815
	Side C	0.24 (Estimate)	0.815
	Side D	0.19 (Estimate)	0.815
	Side E	0.43 (Estimate)	0.815
	Side F	0.37 (Estimate)	0.815
8	Side A	0.19	0.815
	Side B	0.19	0.815
	Side C	0.20	0.815
	Side D	0.19	0.815
	Side E	0.30	0.815
	Side F	0.20	0.815
10	Side A	0.19	0.815
	Side B	0.19	0.815
	Side C	0.19	0.815
	Side D	0.18	0.815
	Side E	0.25	0.815
	Side F	0.19	0.815
12	Side A	0.19	0.815
	Side B	0.18	0.815
	Side C	0.19	0.815
	Side D	0.19	0.815
	Side E	0.24	0.815
	Side F	0.19	0.815
14	Side A	0.18	0.815
	Side B	0.18	0.815
	Side C	0.18	0.815
	Side D	0.18	0.815

	Side E	0.21	0.815
	Side F	0.20	0.815
16	Side A	0.18	0.815
	Side B	0.18	0.815
	Side C	0.18	0.815
	Side D	0.19	0.815
	Side E	0.23	0.815
	Side F	0.13	0.815
	18	Side A	0.18
Side B		0.18	0.815
Side C		0.18	0.815
Side D		0.18	0.815
Side E		0.21	0.815
Side F		0.18	0.815
20	Side A	0.18	0.815
	Side B	0.18	0.815
	Side C	0.18	0.815
	Side D	0.18	0.815
	Side E	0.19	0.815
	Side F	0.15	0.815

12. Test Equipment List

Item	Equipment	Manufacturer	Model No.	Serial No.	Last Cal.	Cal. Interval
1.	Magnetic field probe 100cm ²	Narda	ETL-400 Probe 1Hz-400KHz (r=6.25cm)	O-0167	June 28,2022	1 Year
2.	E-Field Probe	Narda	EP-601	611WX70729	Mar. 23, 2023	1 Year

13. Test Photos

Side A: Test distance 0, 2, 4cm



Side A: Test distance 6cm



Side A: Test distance 8cm



Side A: Test distance 10cm

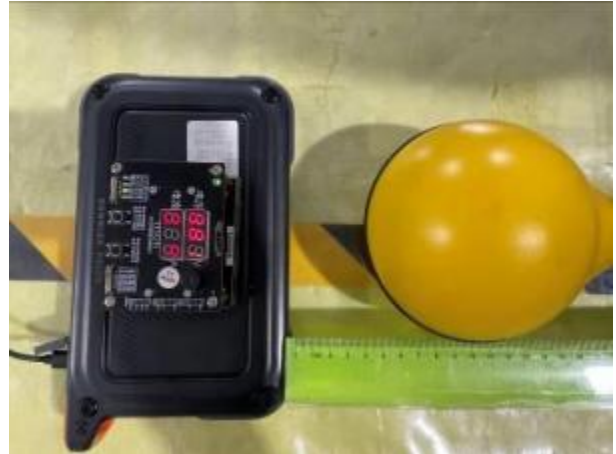

Side A: Test distance 12cm



Side A: Test distance 14cm



Side A: Test distance 16cm



Side A: Test distance 18cm

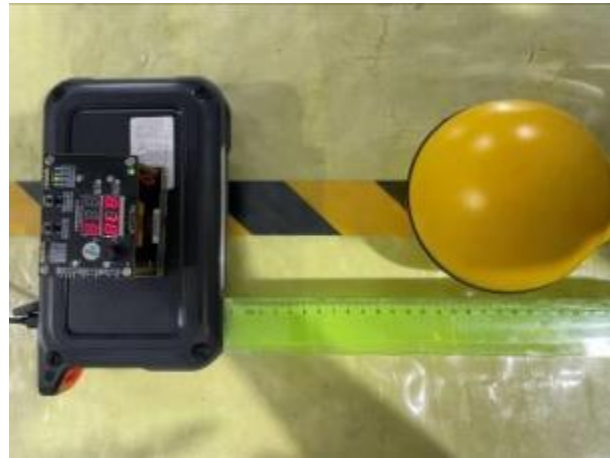

Side A: Test distance 20cm

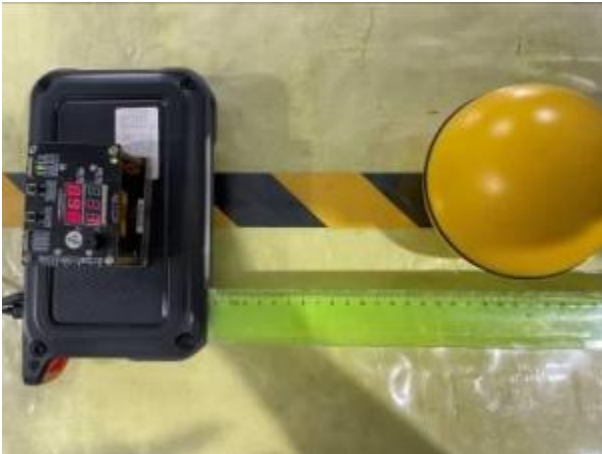

Side B: Test distance 0,2,4cm



Side B: Test distance 6cm



Side B: Test distance 8cm



Side B: Test distance 10cm



Side B: Test distance 12cm



Side B: Test distance 14cm



Side B: Test distance 16cm

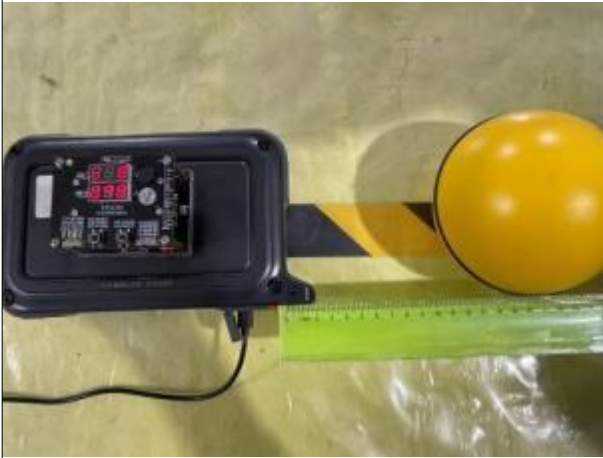

Side B: Test distance 18cm

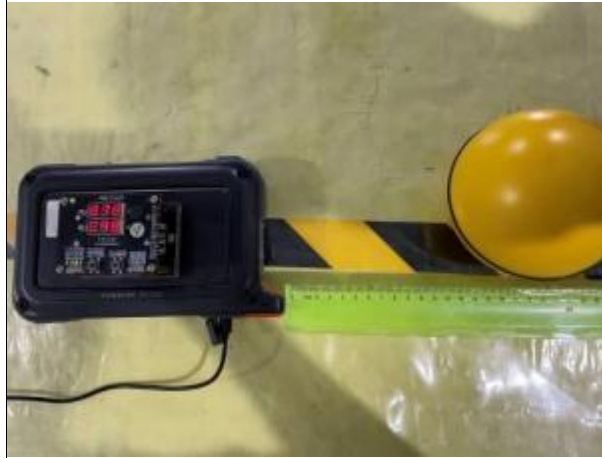

Side B: Test distance 20cm



Side C: Test distance 0,2,4cm

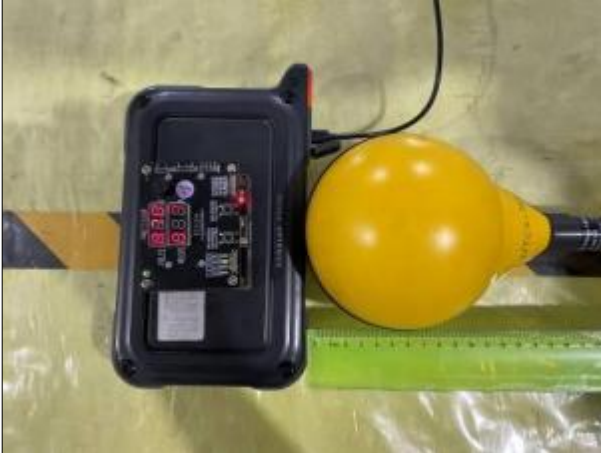

Side C: Test distance 6cm

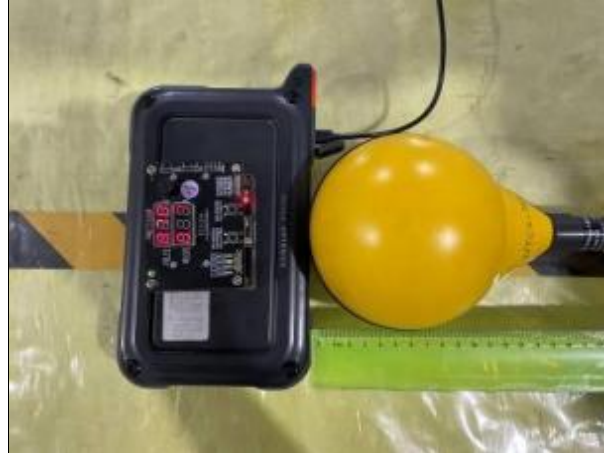

Side C: Test distance 8cm

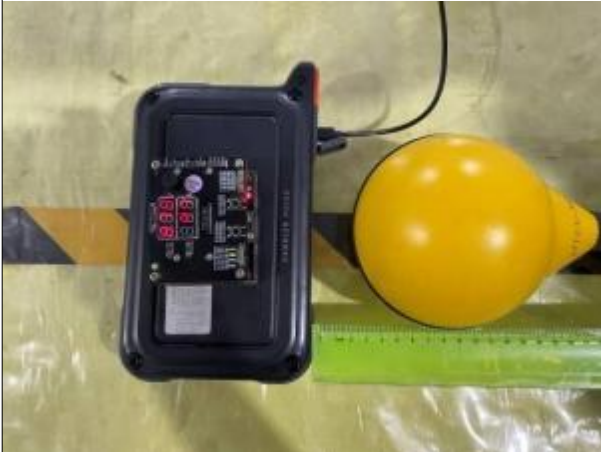

Side C: Test distance 10cm



Side C: Test distance 12cm

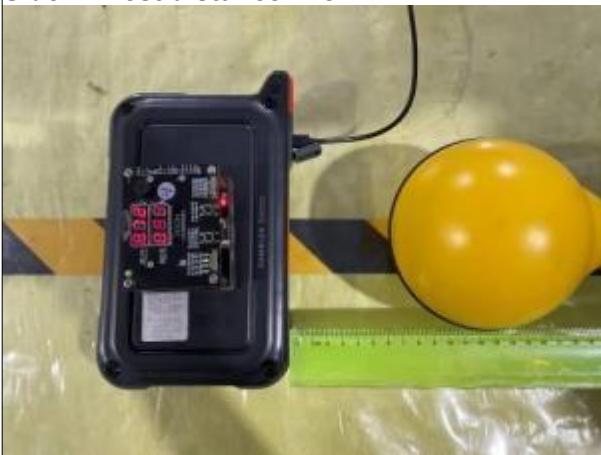

Side C: Test distance 14cm

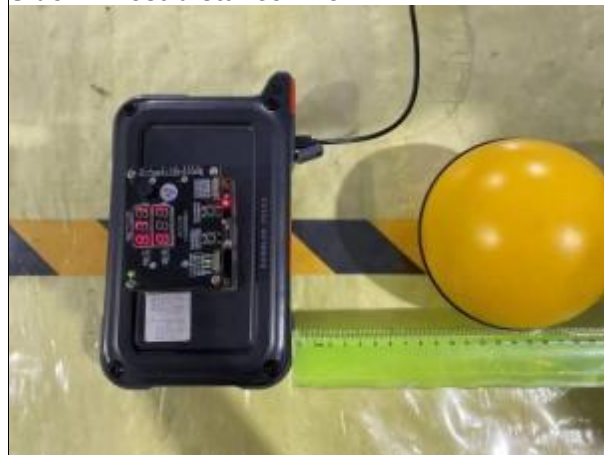

Side C: Test distance 16cm

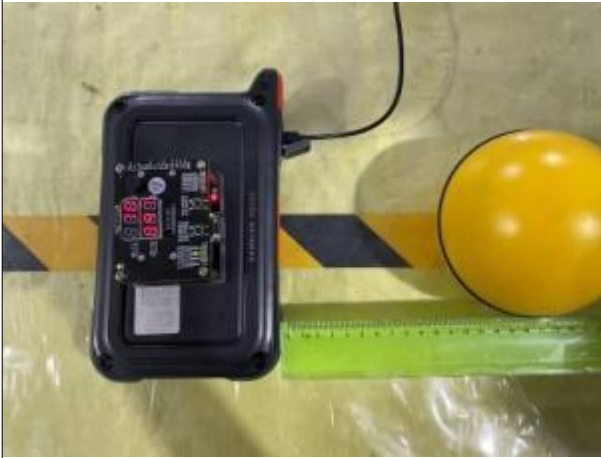

Side C: Test distance 18cm

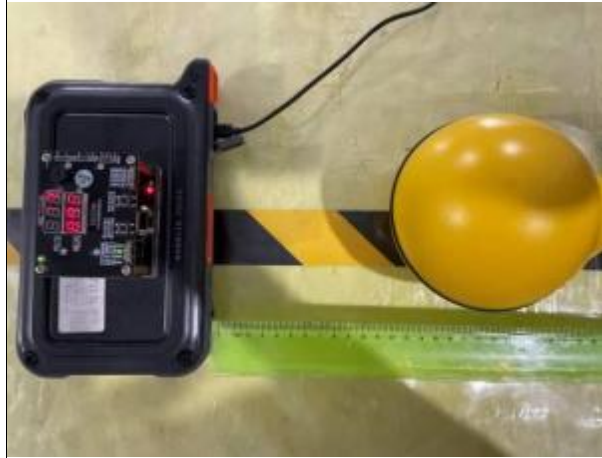

Side C: Test distance 20cm



Side D: Test distance 0,2,4cm

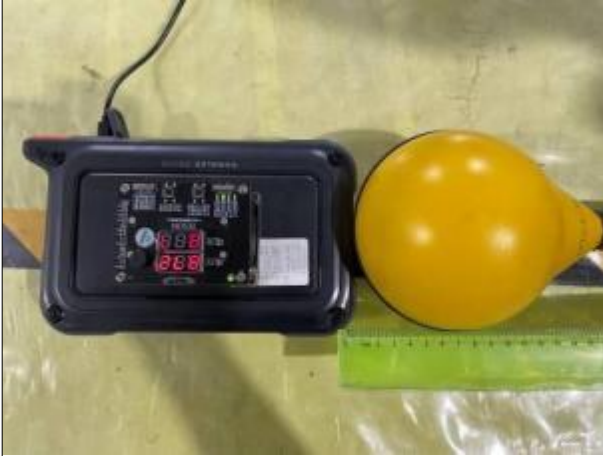

Side D: Test distance 6cm



Side D: Test distance 8cm



Side D: Test distance 10cm



Side D: Test distance 12cm

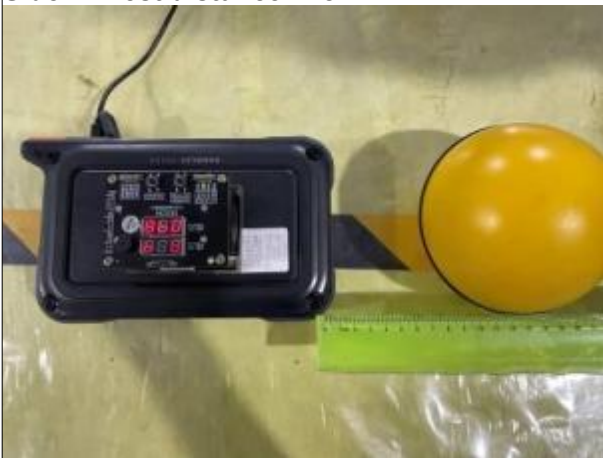

Side D: Test distance 14cm



Side D: Test distance 16cm



Side D: Test distance 18cm



Side D: Test distance 20cm



Side E: Test distance 0,2,4cm

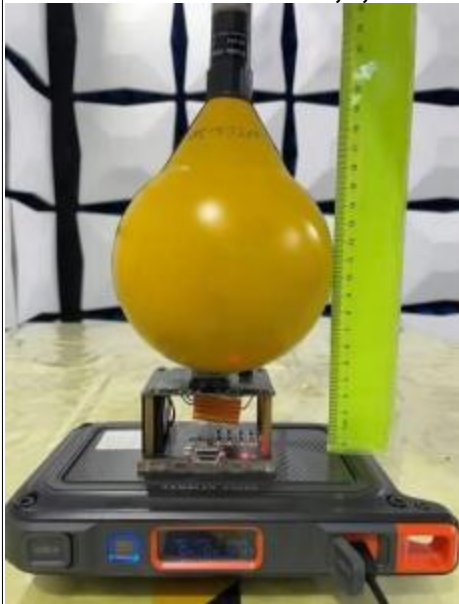

Side E: Test distance 6cm

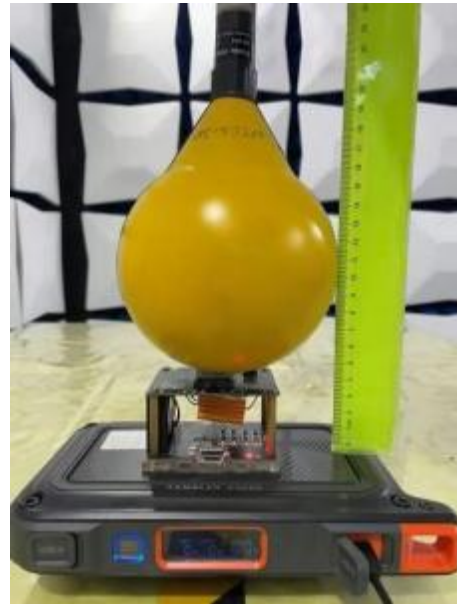

Side E: Test distance 8cm

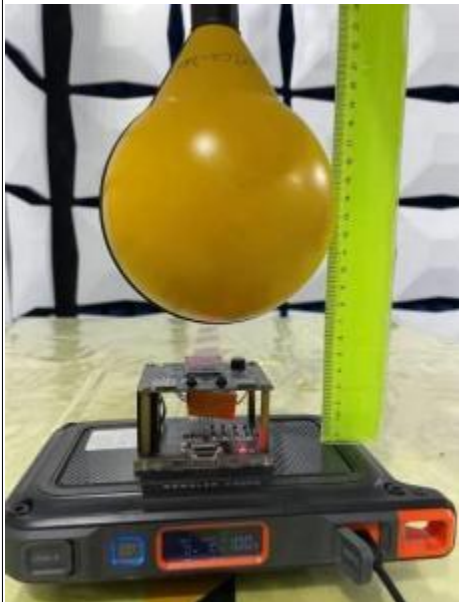

Side E: Test distance 10cm

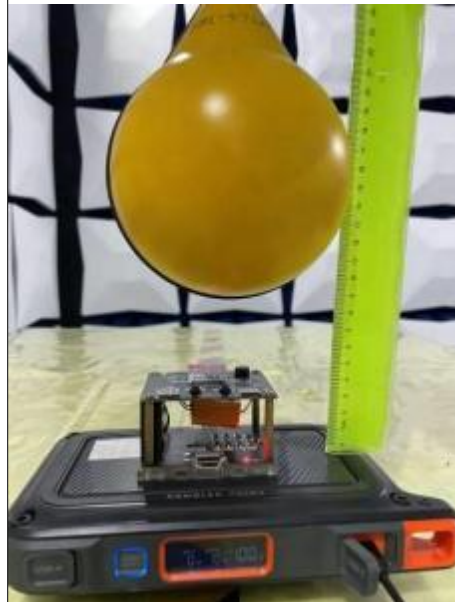

Side E: Test distance 12cm

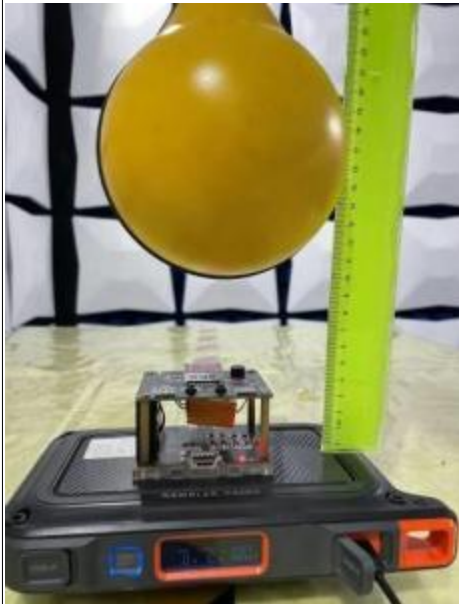

Side E: Test distance 14cm



Side E: Test distance 16cm



Side E: Test distance 18cm



Side E: Test distance 20cm



Side F Test distance 0,2,4cm

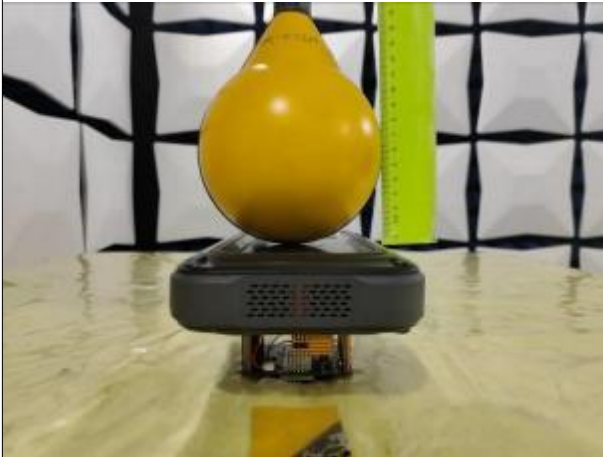

Side F Test distance 6cm

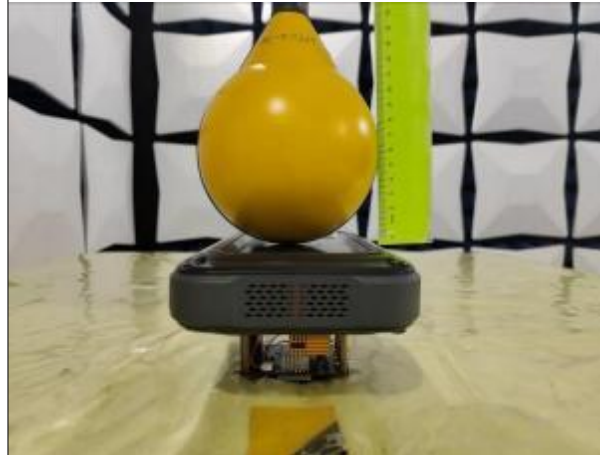

Side F Test distance 8cm

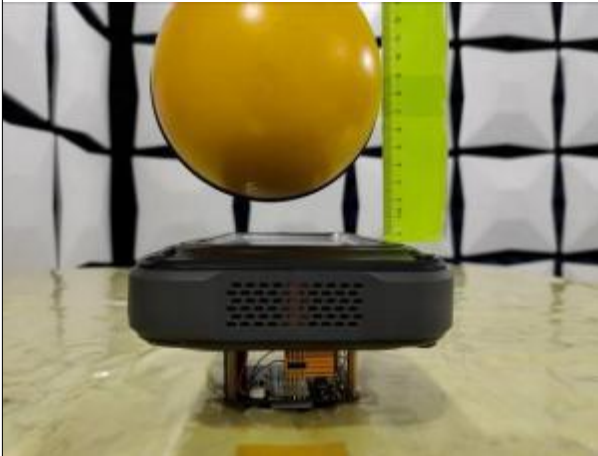

Side F Test distance 10cm

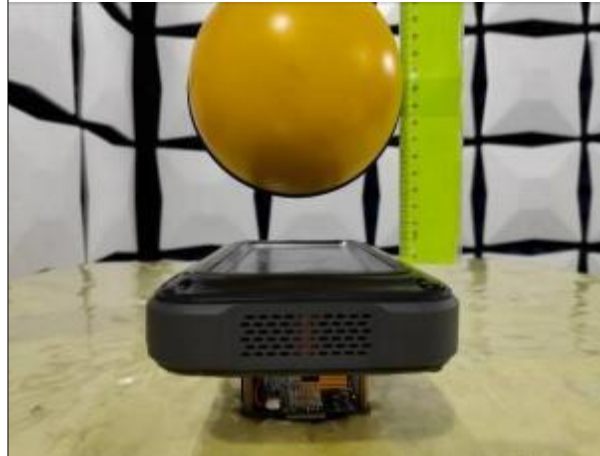

Side F: Test distance 12cm

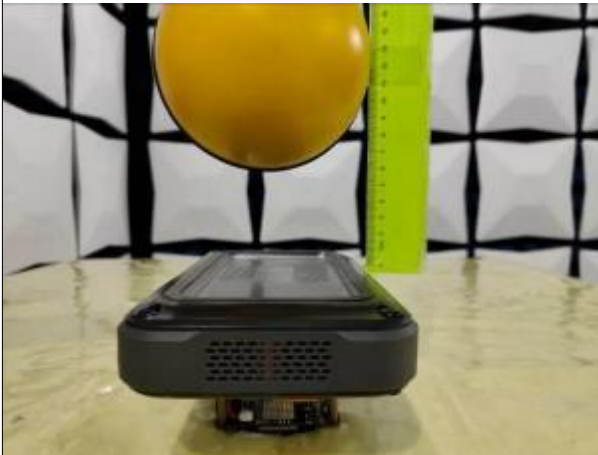

Side F: Test distance 14cm

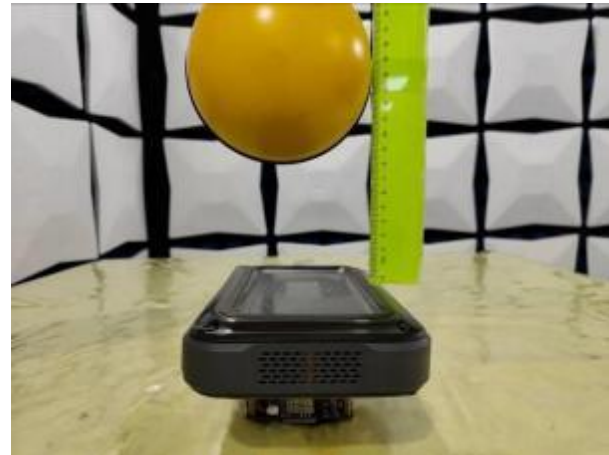

Side F: Test distance 16cm

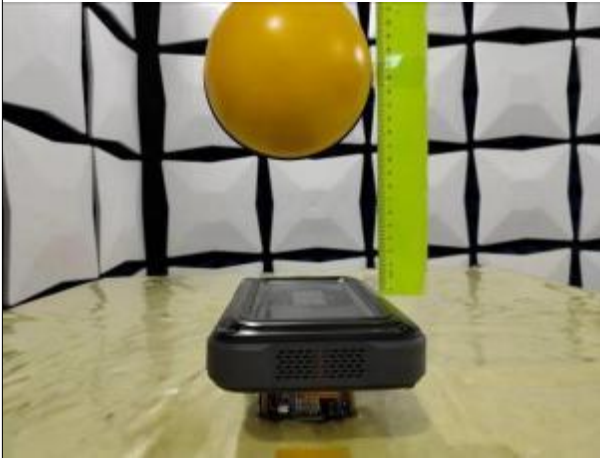

Side F: Test distance 18cm

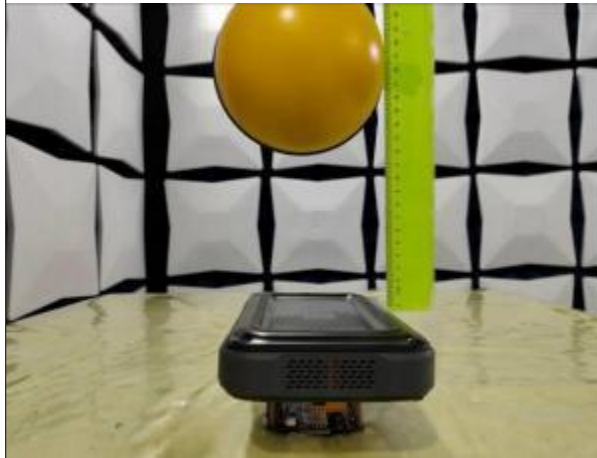

Side F: Test distance 20cm

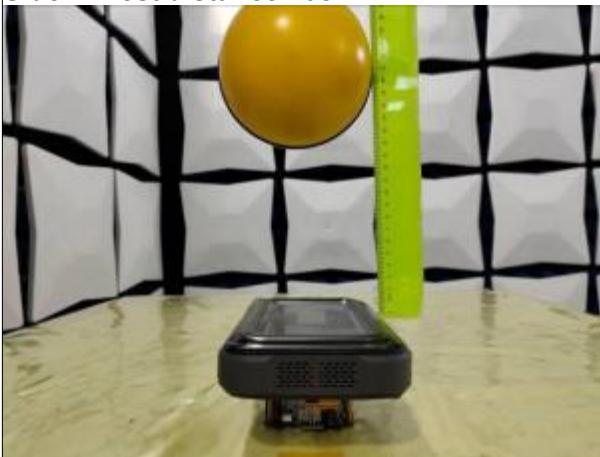

---End---