

DONGGUAN KIMCHEN INDUSTRY INTL LIMITED



DONGGUAN KIMCHEN INDUSTRY INTL LIMITED

**PRODUCT SPECIFICATION**

Shenzhen VIP Innovation Technology Co., Ltd

CUSTOMER: \_\_\_\_\_

CUST P/N: \_\_\_\_\_

J30-000157-001

K C P/N: \_\_\_\_\_

20.5\*40\*0.08\*80P\*11TS\*18MM

D E S E : \_\_\_\_\_

2024.5.6

D A T E : \_\_\_\_\_

A.0

VERSION : \_\_\_\_\_

ACCEPTANCE STAMP

PREPARED BY	MERCHANDISER	ENGINEER CHECKED BY	APPROVED BY
Yan Huilin			

Address: No. 2 Xisha Road, Shijie Town, Dongguan City

Tel: 86-076986018114 Fax: 86-076986015646

Http://www.jzcoil.com

FileNo: KC-JZ-09-008

**Specification •**

CUST P/N

KC DESE

20.5\*40\*0.08\*80P\*PPS\*13MM

DONGGUAN KIMCHEN INDUSTRY INTL LIMITED

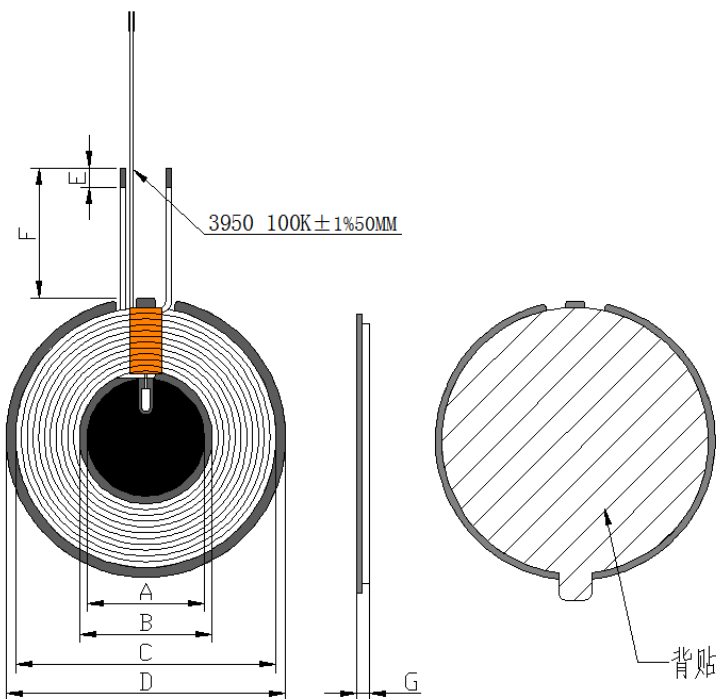

Unit:mm)

A	B	C	D	E	F	G
18±0.5	20.5±0.5	40±1	43±1	3±1	18±3	2.3MAX

PS: 1. (F) is the length of the magnetic outer lead; 2. (G) Includes incoming lines and does not include release paper

Number of laps	Wire diameter	Wdg. Type	Winding direction	Intersect	Coil

PREPARED BY

ENGINEER CHECKED BY

**Yan Huilin**

**Li Dongsheng**

Address: No. 2 Xisha Road, Shijie Town, Dongguan City

Tel: 86-076986018114

Fax: 86-076986015646

Http://www.jzcoil.com

File No: KC-JZ-09-008

<b>Specification •</b>	CUST P/N	
	KC DESE	20.5*40*0.08*80P*11TS*15MM

**DONGGUAN KIMCHEN INDUSTRY INTL LIMITED**

Turns	Wire Dia.	Spred/Close	Wdg. Direction	Yes/Not	Positive/Anti Paste
11TS	0.08*80P (Stranded wire)	(Close)	(Anticlockwise)	Yes	(Anti/-Paste)

All materials require qualified ROHS standards

2. ELECTRICAL CHARACTERISTICS:

TEMPERATURE: 25 ± 10°C, 湿度 RELATIVE HUMIDITY: 65 ± 10%

NO.	ITEM	TERMINAL	SPECIFICATION	TEST FREQUENCY	TEST EQUIPMENTS
1	IND	S-F	Coil with magnetic plate: 7.9uH ± 10%	1kHz/V	LCZ METER 1062

3. BILL OF MATERIAIS:

NO.	Material name	Description	Material Code	Vendor code
1	Wire rod	0.08*80P	JX-2U-F-0008	CX
2	Thermistor	3950 100K ± 1% (Non magnetic) Total length 50MM, tin immersed 3MM, match head 1.5MAX	/	/
2	Large magnetic disc	G435. 30. 8Hwithholeanddoublegroove(middle smallgroove)	GCP-T-00189	LX
3	Small magnetic disc	Hard magnetic circular 18 * 0.8H with U-groove	GCP-T-00317	LX
4	Large double-sided adhesive tape	Circular double-sided tape 40 * 0.08H without holes or slots with ears	SMJ-T-0075	HWD

PREPARED BY	ENGINEER CHECKED BY
<b>Yan Huilin</b>	<b>Li Dongsheng</b>

Address: No. 2 Xisha Road, Shijie Town, Dongguan City

Tel: 86-076986018114

Fax: 86-076986015646

Http://www.jzcoil.com

File No: KC-JZ-09-008

<b>Specification •</b>	CUST P/N	
	KC DESE	20.5*40*0.08*80P*11TS*15MM

**DONGGUAN KIMCHEN INDUSTRY INTL LIMITED**

5	Small double-sided adhesive tape	Circular ordinary double-sided adhesive 13 * 0.08H with hand tearing	SMJ-T-0082	HWD
6	Gold finger adhesive tape	5mm	High temperature adhesive tape 5MM	JRM
7	glue	JS-E7202 (thickened) white glue	E7202W	HZY
8	Tin strip	Environmentally friendly lead-free solder strips	Lead free high-temperature tin strip	XC

PREPARED BY	ENGINEER CHECKED BY
<b>Yan Huilin</b>	<b>Li Dongsheng</b>
Address: No. 2 Xisha Road, Shijie Town, Dongguan City	Tel: 86-076986018114 Fax: 86-076986015646
<a href="http://www.jzcoil.com">Http://www.jzcoil.com</a>	File No: KC-JZ-09-008