

# Product Specification Sheet

<b>Name of client</b>	<b>Huizhou Intelligent Energy Co., Ltd.</b>
<b>Name of product</b>	<b>PORTABLE POWER STATION</b>
<b>Product Model / Version</b>	<b>G300 V1.3.00</b>
<b>Product Specifications</b>	<b>300W/288.6Wh</b>
<b>Specification Version</b>	<b>A0</b>
<b>Date of issue</b>	<b>2022-9-5</b>

<b>Huizhou Intelligent Energy Co., Ltd.</b>		
<b>to copy</b>	<b>To exam ine</b>	<b>Approval</b>
<b>Yang Chao</b>		<b>Gu Jinbo</b>

<b>Customer Signature:</b>		
<b>conf irm</b>	<b>To exam ine</b>	<b>Appr oval</b>

<b>Revision record</b>				
<b>Version number</b>	<b>date</b>	<b>Revised content explanation</b>	<b>Draft</b>	<b>Approval</b>

# catalog

## **1 INTRODUCTION4**

- 1.1 About this product4
- 1.2 About this specification4
- 1.3 Normative reference4

## **2 Product Overview4**

## **3 Schematic diagram of the whole machines5**

## **4 Switches and buttons5**

## **5 LCD screen display5**

## **6 Product function and performance6**

- 6.1 Battery pack characteristics6
- 6.2 DCInput (charge) characteristics6
- 6.3 ACOutput characteristics7
- 6.4 DC5525 + Flare Output Characteristics8
- 6.5 USB-AOutput characteristics8
- 6.6 USB-COutput characteristics8
- 6.7 Wireless charging and output characteristics9
- 6.8 Energy saving and environmental protection characteristics9
- 6.9others10

## **7 Working environment10**

## **8 Compliance with certification or testing standards10**

## **9 Product physical parameters10**

## **10 Packing list11**

## **11 Notes11**

# 1 Introduction

## 1.1 About this product

Product model: G300 (US)

standard) Product

version number: V1.3.00

## 1.2 About this specification

This product specification is compiled and released by the company's product center, which is the specification of the product released by the company, and is an important basis for the company to carry out the relevant work of this product (including production, inspection, testing, certification, marketing, etc.).

This product specification is maintained and updated by the company's product center.

## 1.3 Normative reference

Reference standards are as follows:

- 1) GB31241-2014 "Safety requirements for li-ion cells and pool sets for mobile electronic products" (StateHome Standard No. 1No. The amended)
- 2) GBT35590 - 2017 "General Standard for Mobile Power Supply for Digital Equipment"
- 3) CethTS018-2020 Portable Lithium Ion Battery Energy Storage Power Source Certification Product Specification (for the first time)

# 2 Product Overview

G300 is a standard in line with the United States AC power consumption, the rating of 300 W AC output, using the 18650 Ternary lithium battery, the battery capacity is 288.6Wh Portable energy storage power products, suitable for household emergency electricity, outdoor travel, emergency disaster relief, field work and other occasions.

The product AC total output power is 300 W, with a 120 V AC output, three

QC3.0 Standard USB-A Output, all the way in line with PD60 Standard USB-C Output, two ways DC5V2.5 output With all the cigarette lighter mouth output, built-in 5W LED Lighting and SOS Alarm function, support 10W Wireless charging function.

This product comes standard with 15 V / 4A of AC Adapter Support 120VAC charging, but also supports DC photovoltaic 18V/60-120W Charging and DC12V The car charger charges the product.

### 3 Schematic diagram of the whole machine



### 4 Switches and buttons

Serial number	Key name	Number	Introduction
1.	Master switch button	1 individual	Press the master switch, turn on, LCD screen lights up. Touch and press off. Press the master switch to control: DC5525 With the cigarette lighter output, the control USB-A、USB-C, Wireless Charge Output
2.	AC Output Switch	1 individual	Control the AC output.
3.	DC output switch	nothing	
4.	USB/Wireless charging switch	nothing	
5.	Light switch	1 individual	Normal: Short Press1 Next light, and then short press1 Secondary closure SOS: Continuous Short Press2 Next Flash, Short Press1 Next change light, and then short press1 Secondary closure

## 5 LCD screen display

Serial number	Information item	type	Introductions
6.	Battery power	blend	<p>Displays the current battery charge as an energy column+Percentage presented. The main switch is turned on, and the battery power is displayed.</p> <p>During charging, the energy column is displayed dynamically.</p>
7.	Charging power	numerical value	<p>When charging, "POWER IN" The icon lights up and shows the charging power.</p>
8.	DC output power	numerical value	<p>After the master switch is turned on, "DC OUT" Icon lights up and displays the total DC output of the Use power.</p>
9.	USB/Wireless charging output power	numerical value	<p>After the master switch is turned on, "USB OUT" The icon lights up and displays the USB-A 、 USB-C The total power output of the three wireless charging.</p>

10.	AC output power	numerical value	After the AC output switch is turned on, “AC OUT”The icon lights up and displays the communication Total used power output
11.	Lighting lamp	icon	Light on, light bulb icon on
12.	fan	icon	Core $\geq$ detected45 Degree or power $\geq$ 60%After the rated load, the fan starts, Fan icon lights up
13.	Temperature alarm	icon	The temperature of the battery cell is detected to reach the set protection value, if the charging protection temperature value is reached, the exclamation mark icon flashes, if the discharge temperature protection value is reached, the exclamation mark icon Often bright.

## 6 Product function and performance

### 6.1 Battery pack characteristics

project	Minimum	standard	Maximum	Introductions
Cell type		Li-ion		
Voltage	11.2V	14.6V	16.8V	
capacity	16.95Ah	13AH 288.6Wh		Factory capacity: 0.5C, $\geq$ 16.95Ah (0.2CCharge to16.8V,0.02Ccurrent cutoff,0.5CDischarge toll.2V, resulting capacity)
Charging high temperature protection	45°C	50°C	55°C	Battery temperature exceeds this value, stop charging, charging protection diagram Exclamation point flashing; (via Master Control)
Charging high temperature protection Post-recovery	40°C	45°C	50°C	After the high temperature protection stops charging, it returns to this temperature and automatically recovers. Recharging (via master control)
Low temperature	-5°C	0°C	5°C	Battery temperature below this value, stop charging, charging protection diagram



protection for charging				Exclamation point flashing (via master control)
Low temperature protection for charging Post-recovery	0°C	5°C	10°C	After the low temperature protection stops charging, it returns to this temperature and automatically recovers. Recharging (via master control)
High temperature discharge protection	60°C	65°C	70°C	Battery temperature exceeds this value, stop discharge Discharge protection icon Exclamation point is always bright (via master control)
High temperature discharge protection Post-recovery	55°C	60°C	65°C	High temperature protection after termination of discharge, return to the temperature, you can press Key recovery (via master control)
Discharge cryogenic protection	-10°C	-15°C	-20°C	Cell temperature below this value, stop discharge, discharge protection diagram Exclamation point is always bright (through the main control)
Discharge cryogenic protection Post-recovery	-15°C	-10°C	-5°C	Low temperature protection after termination of discharge, return to the temperature, you can press Key recovery (via master control)

## 6.2 DCinput(Charge ) Characteristic

project	Minimum	standard	Maximum	Intr oduc tions
---------	---------	----------	---------	-----------------

DC Charging mode				Support AC Adapters, car chargers, PV
PV Input port		1 individual		
DC Input port		1 individual		
DC Input voltage	12V	15V	26V	
DC Input current		3.4A	5A	
DC Input power		52W	55W	
PV Input voltage	18V	18V	26V	
PV Input current		3A	5A	
PV Input power		52W	55W	
Car charging input voltage	12V		15V	
Car charger input current		4A	5A	
Car charger input power		48W	55W	
Multiple charging at the same time		Not supported		When charging, only one input mode can be selected to charge the product.
Charge and put		Not supported		Only supported when charging DC, USB Output, not supported AC Output;

### 6.3 AC Output characteristics

project	Minimum	standard	Maximum	Introductions
AC Output Jack		1		Meiji
AC power transfer		300W	310W	Pool Set Voltages 12.8 ~ 16.8 V With PF1.0R Load
Output peak power		600W		Protection Off Output after Maximum Power Continues 200 ms
AC Out Wave		sine wave		Resistance R load

THDV		5%		
AC Frequency	59HZ	60HZ	61HZ	
No-load output voltage	105V	120V	130V	
Output voltage with load	100V	120V	130V	
Inverter efficiency	85%	87%		Load current at rated voltage 40%, 60%, 80%, 100% The Average Efficiency of Four Points with R Load Plate End
AC Effective Output Capacity amount	210wh			Ambient temperature $25 \pm 2$ degrees, rated power test;
AC output short circuit protection protect		Support		Turn off output, no damage to circuit, key recovery
AC Overload Protection	310W	350W	390W	1. ACThe load power is greater than the350WContinued3SPost-trigger overloadProtection, OffAC, Key Recovery 2. DC + USB + ACThe load power is greater than the350WPost-trigger overloadProtection, OffAC, ReservationsDC/USBOutput, key recovery complex
Inverter overtemperature protection	85°C			Turn off the AC output, button recovery

## 6.4 DC5525 + Flare Output Characteristics

project	Minimum	standard	Maximum	Introductions
DC5525 Port		2		
Cigarette Lighter Port		1		
No-load output voltage	11V	12.8V	14V	
Load output voltage	10.5V	12.8V	13.8V	Battery at 13.6V with load 12 V
Output current		10A		Two way 5525 + one way cigarette lighter total output
Output current limiting protection	10.1A	11.5A	13A	Turn off output, no damage to circuit, key recovery
Output short circuit protection		Support		Turn off output, no damage to circuit, key recovery

## 6.5 USB-A Output characteristics

project	Minimum	standard	Maximum	Introductions
USB A port		3		
QC3.0		Support		
Output power		18W		
5V No-load output	4.6V	5V	5.5V	
5V Full Load Outputer	4.65V	5V	5.5V	
5V Positive Current	---	3A	---	
9V No-load output	8.6V	9V	9.5V	
9V Full Load Outputer	8.5V	9V	9.5V	
9V Positive	---	2.0A	---	

Current				
12V No-load output	11.6V	12	12.6V	
12V Full Load Outputer	11.5V	12V	12.5V	
12V Positive Current	---	1.5A	---	
Automatic identification	---	Yes	---	
Output current limiting protection	3.1A	3.8A	4.5A	
Output short circuit protection		Support		Turn off the output, without damaging the circuit, automatic recovery

## 6.6 USB-C Output characteristics

project	Minimum	standard	Maximum	Introductions
USBC port		1		
PD3.0		Support		
Output power		60W		
5V No-load output	4.6V	5V	5.5V	
5V Full Load Outputer	4.5V	5V	5.5V	

5V Positive Current	---	3A	---	
9V No-load output	8.6V	9V	9.5V	
9V Full Load Outputer	8.5V	9V	9.5V	
9V Positive Current	---	3A	---	
12V No-load output	11.6V	12V	12.5V	
12V Full Load Outputer	11.5V	12V	12.5V	
12V Positive Current	---	3A	---	
15V No-load Outputer	14.6V	15V	15.5V	
15V full load output	14.5V	15V	15.5V	
15V Positive Current	---	3A	---	
20V No-load output	19.5V	20V	21V	
20V full load output	19.2V	20V	20.8V	
20V Power Supply Current	---	3A	---	
Automatic identification	---	Yes	---	Output voltage and current according to different load
Output current limiting protection	3.1A	3.8A	4.5A	Turn off the output, do not damage the circuit, self-recovery
Output short circuit protection		Support		Turn off the output, do not damage the circuit, self-recovery

## 6.7 Wireless charging and output characteristics

project	Minimum	standard	Maximum	Introductions
Wireless charging port		1		
Output power		10W		
Output voltage	4.8V	5V	5.3V	
Output current	1.8A	2A	2.3A	
FOD		Support		

Temperature protection	60°C	65°C	70°C	Turn off the output, without damaging the circuit, automatic recovery
------------------------	------	------	------	---

## 6.8 Energy saving and environmental protection characteristics

project	Minimum	standard	Maximum	Introductions
Automatic shutdown		Support		The load power is $\leq 5$ W; Continuous 3 H Automatic Shut Down
Whole machine working idle Power consumption		550mA	650mA	Battery pack output 14.6V, OpenDC. USB. AC Measuring battery B+ End access
When the whole machine shuts down since Electricity consumption		$\leq 1$ mA		
Runtime noise			70db	Less than 35db when fan free and less than 70db when fan starts

## 6.9 Other

project	Minimum	standard	Maximum	Introductions
Lighting power		5W		Surface light source
Illuminant brightness		600LM		Distance 20CM Test
Illuminant color temperature		3000K		
Lights dormancy		3H		After opening, 3HInside unopened beltDC, USB, ACAny function, Turn off the light and enter sleep;

## 7 Working environment

project	Minimum	standard	Maximum	Introductions
Charging operating temperature	0°C	25°C	40°C	environmental temperature
Discharge operating temperature	-10°C	25°C	40°C	environmental temperature
Storage temperature	-20°C	---	45°C	
Working humidity	10%	---	75%	
Storage humidity		---	45%	
altitude			2000 rice	
Test ambient temperature	23°C	25°C	27°C	
<p>If the battery is stored for more than three months, please use the charger with the specified parameter range to charge and discharge the product once. Charge to50%;</p>				



## 8 Compliance with certification or testing standards

According to the needs of customers can do the following certification or record: UL2743 report / FCC-sDOC / FCC-ID / UN 38.3 / MSDS / UN box performance list / dangerous package certificate, the cost is the customer's responsibility.

<b>Certification Program</b>	<b>Certification Implementation Standards</b>
FCC-sDOC	FCC 47 CFR Part 15 Subpart B: 2022
FCC-ID	FCC Part15 Subpart C, Paragraph 15.209
UL2743	UL 2743. Edition 2. Revision 2020
UN38.3	ST/SG/AC.10/11/Rev.7/Amend.1

## 9 Product physical parameters

The maximum size of the machine appearance:

244 \* 171.4 \* 177mm, The body weight:

3.81KG,

---

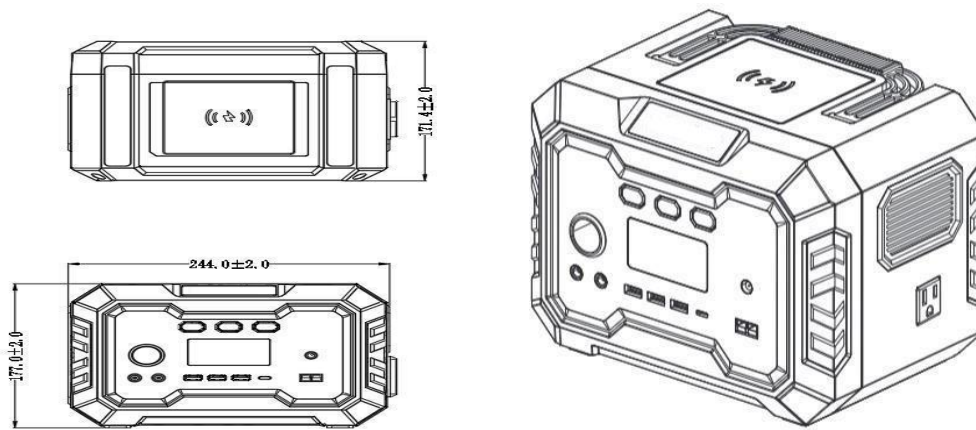

## 10 Packing list

Serial number	name	Specifications	Number
1	G300	300W/288.6Wh	1
2	User's manual	G300 :142*210mm	1
3	AC Fit	American Standard 15V4A 60W	1

## 11 Note

1. Do not put the product into water or rain!
2. Do not heat the product or approach the fire source! Do not disassemble or transform the product without authorization! Do not hit the product hard! otherwise May cause battery overheating, short circuit, fire or failure of function, shortened life and other hazards.
3. Do not use or place this product in high temperatures (in hot sunlight or in very hot cars), otherwise it may cause overheating of the battery, fire or failure of function, short life, and other hazards.
4. Prohibit disassembly and disassembly of power supply
5. Prohibit short circuit of the power battery
6. Prohibit the use of non-dedicated charger to charge the power supply, it will be dangerous;
7. Do not directly touch the leaking battery, the leakage of electrolyte will cause

skin discomfort, in case the electrolyte enters the eyes, rinse with water as soon as possible, do not rub the eyes, and quickly sent to the hospital;

FCC STATEMENT : This device complies with Part 15 of the FCC Rules. Operation is subject to the following two conditions: (1) This device may not cause harmful interference, and (2) This device must accept any interference received, including interference that may cause undesired operation. Warning: Changes or modifications not expressly approved by the party responsible for compliance could void the user's authority to operate the equipment. NOTE: This equipment has been tested and found to comply with the limits for a Class B digital device, pursuant to Part 15 of the FCC Rules. These limits are designed to provide reasonable protection against harmful interference in a residential installation. This equipment generates uses and can radiate radio frequency energy and, if not installed and used in accordance with the instructions, may cause harmful interference to radio communications. However, there is no guarantee that interference will not occur in a particular installation. If this equipment does cause harmful interference to radio or television reception, which can be determined by turning the equipment off and on, the user is encouraged to try to correct the interference by one or more of the following measures: Reorient or relocate the receiving antenna. Increase the separation between the equipment and receiver. Connect the equipment into an outlet on a circuit different from that to which the receiver is connected. Consult the dealer or an experienced radio/TV technician for help. FCC Radiation Exposure Statement: This equipment complies with FCC radiation exposure limits set forth for an uncontrolled environment. This equipment should be installed and operated with minimum distance 20cm between the radiator & your body.

---