

FCC TEST REPORT

For

Insulin Pump

Model Number: AR-B200A, AR-B200B, AR-B200C, AR-B200D

FCC ID: 2BARWB200

Report Number : WT238000027

Test Laboratory : Shenzhen Academy of Metrology and Quality
Inspection
Site Location : NETC Building, No.4 Tongfa Rd., Xili, Nanshan,
Shenzhen, China
Tel : 0086-755-86928965
Fax : 0086-755-86009898-31396
Web : www.smq.com.cn
E-mail : emcrf@smq.com.cn

Revision History

No	Date	Remark
V1.0	2023.03.17	Initial issue

TEST REPORT DECLARATION

Applicant : AARUY Medical Electronics Co., Ltd.
Address : 20/F, West Block, Skyworth Semiconductor Design Building,
Shenzhen, China
Manufacturer : AARUY Medical Electronics Co., Ltd.
Address : 20/F, West Block, Skyworth Semiconductor Design Building,
Shenzhen, China
EUT Description : Insulin Pump
Model No. : AR-B200A, AR-B200B, AR-B200C, AR-B200D
Trade mark : aaruy
Serial Number : /
FCC ID : 2BARWB200

Test Standards:

FCC Part 15 Subpart B

The EUT described above is tested by Shenzhen Academy of Metrology and Quality Inspection EMC Laboratory to determine the maximum emissions from the EUT. Shenzhen Academy of Metrology and Quality Inspection EMC Laboratory is assumed full responsibility for the accuracy of the test results.

The test report is valid for above tested sample only and shall not be reproduced in part without written approval of the laboratory.

Project Engineer:  Date: Mar.17, 2023
(Zhou Fangai 周芳媛)
Checked by:  Date: Mar.17, 2023
(Wan Xiaojing 万晓婧)
Approved by:  Date: Mar.17, 2023
(Lin Yixiang 林奕翔)

TABLE OF CONTENTS

TEST REPORT DECLARATION	3
1. TEST RESULTS SUMMARY	5
2. GENERAL INFORMATION.....	6
2.1. Report information.....	6
2.2. Laboratory Accreditation and Relationship to Customer	6
2.3. Measurement Uncertainty	6
3. PRODUCT DESCRIPTION.....	8
3.1. EUT Description.....	8
3.2. Operating Condition of EUT	8
3.3. Support Equipment List	9
3.4. Test Conditions.....	9
3.5. Modifications	9
4. TEST EQUIPMENT USED	10
5. CONDUCTED EMISSION TEST	11
5.1. Test Standard and Limit	11
5.2. Test Procedure	11
5.3. Test Arrangement.....	11
5.4. Test Data	11
6. RADIATION EMISSION TEST.....	14
6.1. Test Standard and Limit	14
6.2. Test Procedure	14
6.3. Test Arrangement.....	15
6.4. Test Data	15

1. TEST RESULTS SUMMARY

Table 1 Test Results Summary

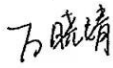
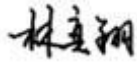
Test Items	FCC Rules	Test Results
Conducted Emission	15.107	Pass
Radiation Emission	15.109	Pass

Remark: "N/A" means "Not applicable."

2. GENERAL INFORMATION

2.1. Report information

This report is not a certificate of quality; it only applies to the sample of the specific product/equipment given at the time of its testing. The results are not used to indicate or imply that they are application to the similar items. In addition, such results must not be used to indicate or imply that SMQ approves recommends or endorses the manufacture, supplier or use of such product/equipment, or that SMQ in any way guarantees the later performance of the product/equipment.

The sample/s mentioned in this report is/are supplied by Applicant, SMQ therefore assumes no responsibility for the accuracy of information on the brand name, model number, origin of manufacture or any information supplied.

Additional copies of the report are available to the Applicant at an additional fee. No third part can obtain a copy of this report through SMQ, unless the applicant has authorized SMQ in writing to do so.

The lab will not be liable for any loss or damage resulting for false, inaccurate, inappropriate or incomplete product information provided by the applicant/manufacturere.

2.2. Laboratory Accreditation and Relationship to Customer

The testing report were performed by the Shenzhen Academy of Metrology and quality Inspection EMC Laboratory (Guangdong EMC compliance testing center), in their facilities located at NETC Building, No.4 Tongfa Rd., Xili, Nanshan, Shenzhen, China. At the time of testing, Laboratory is accredited by the following organizations:

China National Accreditation Service for Conformity Assessment (CNAS) accredits the Laboratory for conformance to FCC standards, EMC international standards and EN standards. The Registration Number is CNAS L0579.

The Laboratory is Accredited Testing Laboratory of FCC with Designation number CN1165 and Site registration number 582918.

The Laboratory is registered to perform emission tests with Innovation, Science and Economic Development (ISED), and the registration number is 11177A.

The Laboratory is registered to perform emission tests with VCCI, and the registration number are C-20048, G20076, R-20077, R-20078 and T-20047.

The Laboratory is Accredited Testing Laboratory of American Association for Laboratory Accreditation (A2LA) and certificate number is 3292.01.

2.3. Measurement Uncertainty

Conducted Emission

9 kHz~150 kHz $U=3.7\text{dB}$ $k=2$
150 kHz~30MHz $U=3.3\text{dB}$ $k=2$

Radiated Emission

30MHz~1000MHz $U=4.3\text{dB}$ $k=2$
1GHz~6GHz $U=4.6\text{ dB}$ $k=2$
6GHz~40GHz $U=5.1\text{dB}$ $k=2$

3. PRODUCT DESCRIPTION

NOTE: The extreme test conditions for temperature and antenna gain were declared by the manufacturer.

3.1. EUT Description

Description : Insulin Pump
 Manufacturer : AARUY Medical Electronics Co., Ltd.
 Model Number : AR-B200A, AR-B200B, AR-B200C, AR-B200D
 Test voltage : AC 120V/60Hz
 Software Version : V1.0.1.02
 Hardware Version : A2
 Frequency : Bluetooth:2402MHz~2480MHz
 Type(s) of Modulation : GFSK
 Antenna Type : Internal Antenna -2.34dBi

Remark: The four models of insulin pump are AR-B200A, AR-B200B, AR-B200C, AR-B200D.

All of the models' circuit theory, electrical design and critical components are the same. The differences lie in fixing hole of the catheter and extended bolus & bolus guide function, as shown in the table below.

Table 2 Differences among models listed in table below

Item	AR-B200A	AR-B200B	AR-B200C	AR-B200D
Fixing hole of the catheter	√	√	×	×
Extended bolus & bolus guide function	√	×	√	×

Unless otherwise specified, the model of AR-B200A was chosen as representative to perform all the tests.

3.1. Block Diagram of EUT Configuration

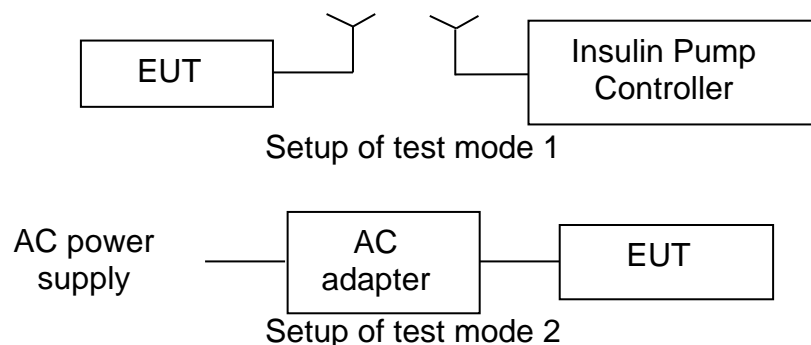

3.2. Operating Condition of EUT

Test mode 1: Connect to Insulin Pump Controller

Test mode 2: Charging

EUT has more than one typical operation, only the worst test mode will be recorded in this report.

The Radiated emission measurements were carried out in semi-anechoic chamber with 3-meter test range, and EUT is rotated on three test planes to find out the worst emission (X plane).

3.3. Support Equipment List

Table 3 Support Equipment List

Name	Model No.	S/N	Manufacturer
Insulin Pump Controller	AR-K300	---	AARUY Medical Electronics Co., Ltd.
Adapter for EUT	LXCP12X-050100DG	---	Shenzhen Longxc Power Supply Co.,LTD.
Insulin Pump battery charger	AR-ADP5V020	---	AARUY Medical Electronics Co., Ltd.
Rechargeable Li-ion Polymer Battery for EUT	AR-BATB200	---	AARUY Medical Electronics Co., Ltd.

3.4. Test Conditions

Date of test : Mar.06, 2023 – Mar.07, 2023

Date of EUT Receive : Jan.05, 2023

Temperature: 20°C-21°C

Relative Humidity: 36%-49%

3.5. Modifications

No modification was made.

4. TEST EQUIPMENT USED

Table 4 Test Equipment List

No.	Equipment	Manufacturer	Model No.	LAST CALIB	Period
Conducted Emission					
SB9058/05	Test Receiver	R&S	ESCI 3	Sep.13,2022	1 Year
SB4357	AMN	R&S	ENN216	Aug.23,2022	1 Year
SB9549	Shielded Room	Albatross	SR	Sep.06,2022	1 Year
Radiated Emission					
SB17366	Test Receiver	R&S	ESR26	Jun.22,2022	1 Year
SB3955	Broadband Antenna	Schwarzbeck	VULB9163	Jun.06,2022	1 Year
SB13958	Horn Antenna	R&S	HF907	Mar.22,2022	1 Year
SB9555/01	Semi Anechoic Chamber	Albatross	9×6×6(m)	Aug.16,2022	1 Year

5. CONDUCTED EMISSION TEST

5.1. Test Standard and Limit

5.1.1. Test Standard

FCC Part 15: Section 15.107

5.1.2. Test Limit

Table 5 Conducted Emission Test Limit (Class B)

Frequency	Power Port limits (dB μ V)	
	Quasi-peak	Average
0.15MHz ~ 0.5MHz	66~56*	56~46*
0.5MHz ~ 5 MHz	56	46
5 MHz ~ 30MHz	60	50

* Decreasing linearly with logarithm of the frequency

5.2. Test Procedure

The EUT is put on a table of non-conducting material that is 80cm high. The vertical conducting wall of shielding is located 40cm to the rear of the EUT. The power line of the EUT is connected to the AC mains through a Artificial Mains Network (A.M.N.). A EMI test receiver is used to test the emissions from both sides of AC line. The bandwidth of EMI test receiver is set at 9kHz.

5.3. Test Arrangement

The arrangement of the equipment is installed to meet the standards and operating in a manner, which tends to maximize its emission characteristics in a normal application. The detailed information refers to test picture.

5.4. Test Data

The emissions don't show in below are too low against the limits. Refer to the test curves.

Table 6 Conducted Emission Test Data at mains Port

Test mode: 2								
	Frequency (MHz)	Correction Factor (dB)	Quasi-Peak			Average		
			Reading (dB μ V)	Emission Level (dB μ V)	Limits (dB μ V)	Reading (dB μ V)	Emission Level (dB μ V)	Limits (dB μ V)
Line	0.312	9.7	24.9	34.6	59.9	18.9	28.6	49.9
	0.384	9.7	33.1	42.8	58.2	26.4	36.1	48.2
	0.640	9.8	21.3	31.1	56	13.5	23.3	46
	0.762	9.8	23.2	33.0	56	14.1	23.9	46
	1.009	9.8	22.3	32.1	56	13.9	23.7	46
	1.410	9.8	19.6	29.4	56	12.7	22.5	46
Neutral	0.384	9.7	30.6	40.3	58.2	18.3	28.0	48.2
	0.510	9.8	17.8	27.6	56	5.5	15.3	46
	0.856	9.8	17.0	26.8	56	3.9	13.7	46
	1.275	9.8	16.4	26.2	56	3.8	13.6	46
	1.626	9.8	15.3	25.1	56	2.9	12.7	46
	1.999	9.8	14.5	24.3	56	2.6	12.4	46

- REMARKS: 1. Emission level (dB μ V) =Read Value (dB μ V) + Correction Factor (dB)
 2. Correction Factor (dB) =LISN Factor (dB) + Cable Factor (dB) +Limiter Factor (dB)
 3. The other emission levels were more than 20dB below the limits.

Line

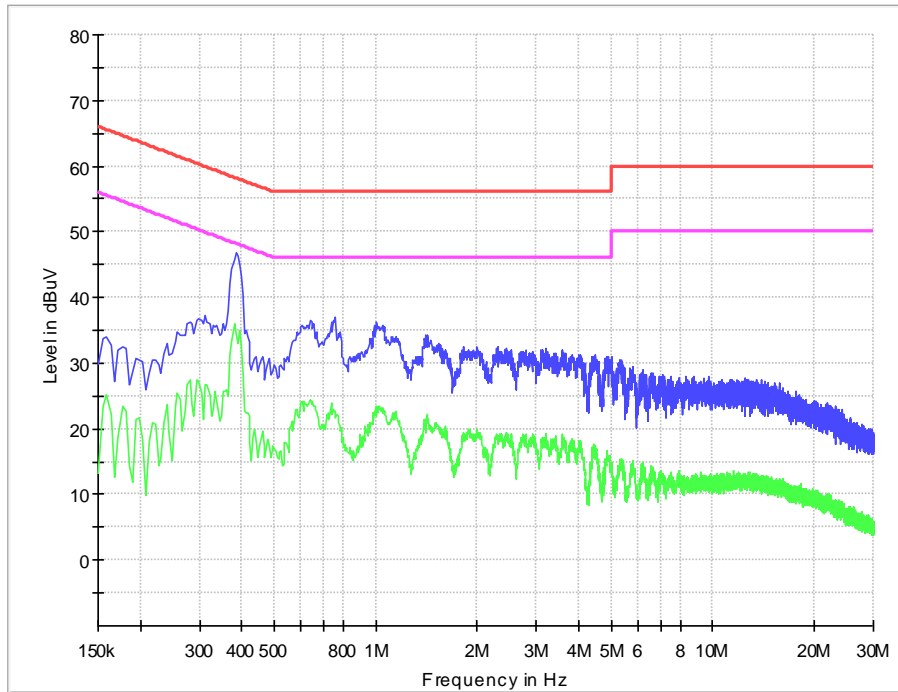

Neutral

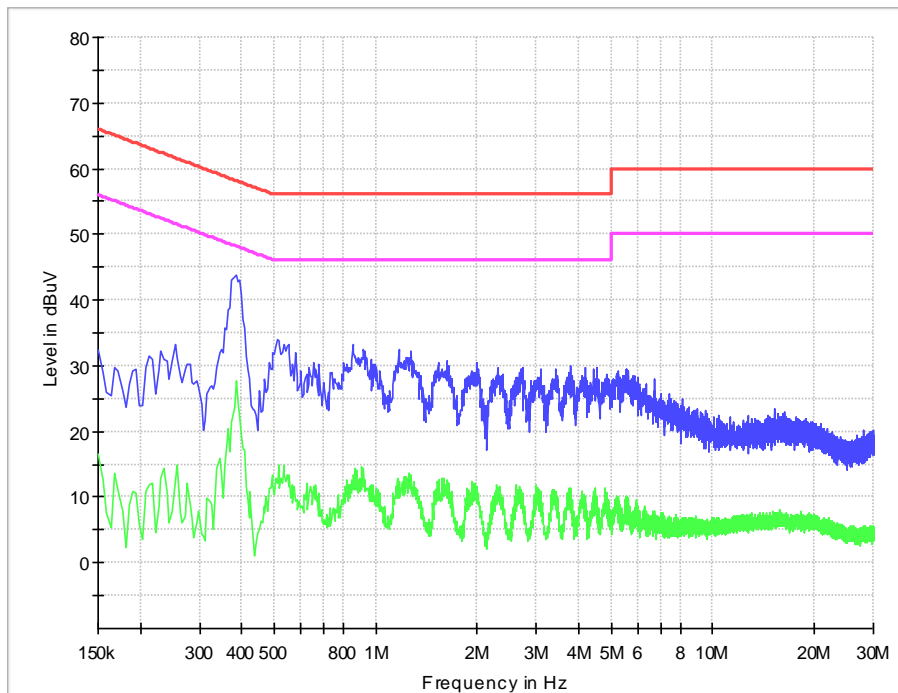

6. RADIATION EMISSION TEST

6.1. Test Standard and Limit

6.1.1. Test Standard

FCC Part 15: Section 15.109

6.1.2. Test Limit

Table 7 Radiation Emission Test Limit for FCC (Class B)

Frequency	Test distance	Limit dB(μ V/m)		
		Quasi-peak	Average	Peak
30MHz~88MHz	3m	40	/	/
88MHz~216MHz	3m	43.5		
216MHz~960MHz	3m	46		
960MHz~1000MHz	3m	54		
>1000MHz	3m		54	74
Conditional testing procedure for above 1 GHz :				
Highest frequency generated or used in the device or on which the device operates or tunes (MHz)		Upper frequency of measurement range (MHz)		
Below 1.705		30		
1.705~108		1000		
108~500		2000		
500~1000		5000		
Above 1000		5th harmonic of the highest frequency or 40 GHz, whichever is lower.		

* The lower limit shall apply at the transition frequency.

* The test distance is 3m.

6.2. Test Procedure

The EUT is placed on a turntable, which is 0.8 meter above ground. The turntable can rotate 360 degrees to determine the position of the maximum emission level. EUT is set **3 meters** away from the receiving antenna, which is mounted on an antenna tower. The antenna can move up and down between 1 to 4 meters to find out the maximum emission level. Broadband antenna is used as a receiving antenna. Both horizontal and vertical polarization of the antenna is set on test.

RBW = 100 kHz (less than or equal to 1 GHz); 1 MHz (above 1 GHz)

VBW \geq 3 x RBW

Detector = Peak & Quasi-Peak (frequency range 30 MHz to 1 GHz);

Peak & Average (frequency range above 1 GHz);

Changing VBW to 10 Hz for average measurement

The use of a higher-than-specified video bandwidth produces a conservative measurement result.

6.3. Test Arrangement

The arrangement of the equipment is installed to meet the standards and operating in a manner, which tends to maximize its emission characteristics in a normal application. The detailed information refers to test picture.

6.4. Test Data

The emissions don't show in below are too low against the limits. Refer to the test curves.

Table 8 Radiated Emission Test Data

Test mode: 1								
Frequency (MHz)	Cable Loss +preamp (dB)	Antenna Factor (dB)	Reading (dBµV/m)	Level (dBµV/m)	Polarity (Horizontal/Vertical)	Limits (dBµV/m)	Margin (dB)	Note
43.580	0.7	13.6	-1.9	12.4	Vertical	40	27.6	QP
95.767	1.1	12.8	-1.5	12.4	Vertical	43.5	31.1	QP
884.085	3.8	20.1	0.5	24.4	Vertical	46	21.6	QP
59.391	0.9	13.0	-1.4	12.5	Horizontal	40	27.5	QP
109.346	1.2	13.2	-2.0	12.4	Horizontal	43.5	31.1	QP
881.660	3.8	20.1	-0.7	23.2	Horizontal	46	22.8	QP
13710.100	-34.4	39.0	50.2	54.8	Vertical	74	19.2	PK
14175.000	-34.8	39.8	50.9	55.9	Vertical	74	18.1	PK
15167.000	-34.6	40.4	52.0	57.8	Vertical	74	16.2	PK
16087.200	-33.5	41.3	50.6	58.4	Vertical	74	15.6	PK
16957.400	-32.3	42.2	51.0	60.9	Vertical	74	13.1	PK
17875.600	-32.3	43.3	50.6	61.6	Vertical	74	12.4	PK
13539.100	-34.4	38.8	51.4	55.8	Horizontal	74	18.2	PK
14372.200	-34.2	40.0	51.0	56.8	Horizontal	74	17.2	PK
15263.000	-34.1	40.8	51.1	57.8	Horizontal	74	16.2	PK
16213.000	-33.8	41.4	51.3	58.9	Horizontal	74	15.1	PK
16927.300	-32.3	42.2	50.7	60.6	Horizontal	74	13.4	PK
17875.900	-32.3	43.3	50.9	61.9	Horizontal	74	12.1	PK
13710.100	-34.4	39.0	37.8	42.4	Vertical	54	11.6	AV
14175.000	-34.8	39.8	38.2	43.2	Vertical	54	10.8	AV
15167.000	-34.6	40.4	39.1	44.9	Vertical	54	9.1	AV
16087.200	-33.5	41.3	38.1	45.9	Vertical	54	8.1	AV
16957.400	-32.3	42.2	37.9	47.8	Vertical	54	6.2	AV
17875.600	-32.3	43.3	36.9	47.9	Verticals	54	6.1	AV
13539.100	-34.4	38.8	37.9	42.3	Horizontal	54	11.7	AV
14372.200	-34.2	40.0	37.6	43.4	Horizontal	54	10.6	AV
15263.000	-34.1	40.8	38.1	44.8	Horizontal	54	9.2	AV
16213.000	-33.8	41.4	38.3	45.9	Horizontal	54	8.1	AV
16927.300	-32.3	42.2	37.5	47.4	Horizontal	54	6.6	AV

17875.900	-32.3	43.3	37.4	48.4	Horizontal	54	5.6	AV
-----------	-------	------	------	------	------------	----	-----	----

Emission level (dBuV)=Read Value(dBuV/m) + Antenna Factor(dB)+ Cable Loss +preamp(dB)

30MHz-1GHz

Horizontal

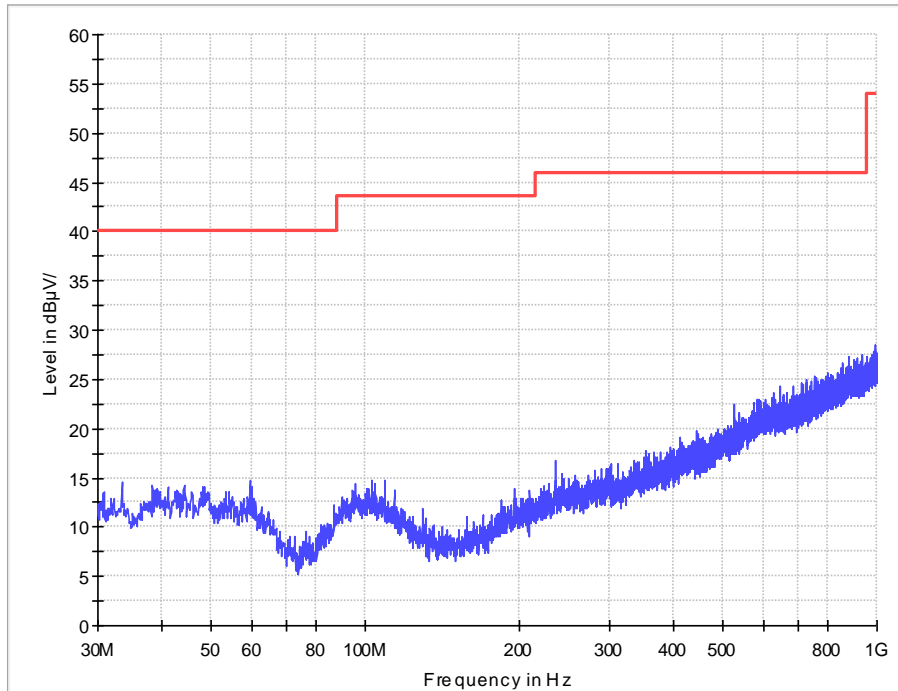

Vertical

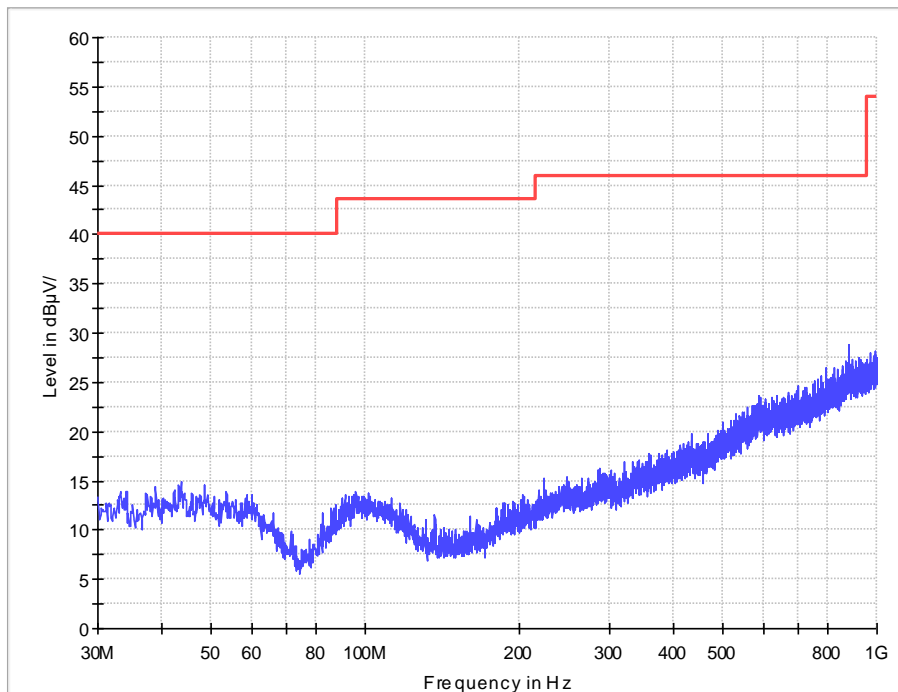

1GHz-18GHz

Horizontal

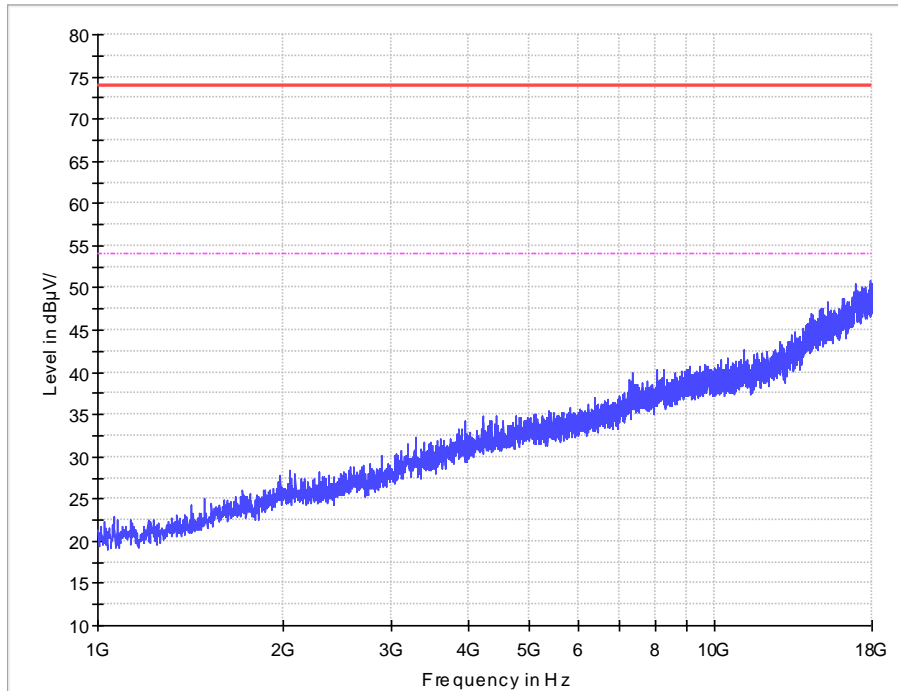

Vertical

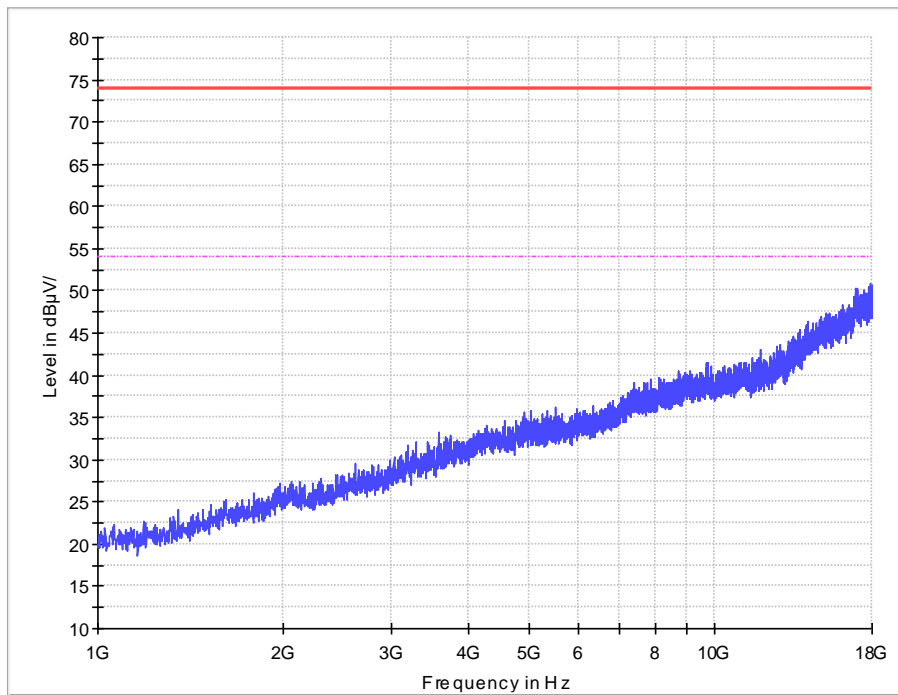

Table 9 Radiated Emission Test Data

Test mode: 2								
Frequency (MHz)	Cable Loss +preamp (dB)	Antenna Factor (dB)	Reading (dBµV/m)	Level (dBµV/m)	Polarity (Horizontal/Vertical)	Limits (dBµV/m)	Margin (dB)	Note
31.746	0.6	12.3	9.9	22.8	Vertical	40	17.2	QP
37.857	0.7	12.3	13.4	26.4	Vertical	40	13.6	QP
43.192	0.8	13.6	4.4	18.8	Vertical	40	21.2	QP
103.332	1.2	13.2	1.1	15.5	Vertical	43.5	28.0	QP
183.375	1.5	9.7	5.7	16.9	Vertical	43.5	26.6	QP
201.108	1.6	10.6	14.2	26.4	Vertical	43.5	17.1	QP
31.764	0.6	12.3	0.0	12.9	Horizontal	40	27.1	QP
42.416	0.8	13.6	0.2	14.6	Horizontal	40	25.4	QP
99.743	1.1	12.8	0.2	14.1	Horizontal	43.5	29.4	QP
160.950	1.5	8.7	4.6	14.8	Horizontal	43.5	28.7	QP
203.339	1.6	10.6	10.0	22.2	Horizontal	43.5	21.3	QP
937.629	4.0	21.1	-4.5	20.6	Horizontal	46	25.4	QP
13508.600	-34.5	38.8	51.3	55.6	Vertical	74	18.4	PK
14576.000	-34.0	40.2	50.2	56.4	Vertical	74	17.6	PK
15196.700	-34.6	40.4	52.1	57.9	Vertical	74	16.1	PK
15654.500	-33.8	41.0	51.0	58.2	Vertical	74	15.8	PK
16927.000	-32.3	42.2	51.3	61.2	Vertical	74	12.8	PK
17705.000	-31.7	43.1	49.2	60.6	Vertical	74	13.4	PK
14059.400	-34.9	39.8	52.2	57.1	Horizontal	74	16.9	PK
14855.000	-34.4	40.5	51.6	57.7	Horizontal	74	16.3	PK
15569.700	-33.9	40.8	51.3	58.2	Horizontal	74	15.8	PK
16419.700	-33.4	41.6	50.7	58.9	Horizontal	74	15.1	PK
16998.600	-32.0	42.2	50.4	60.6	Horizontal	74	13.4	PK
17850.800	-31.9	43.3	48.5	59.9	Horizontal	74	14.1	PK
13508.600	-34.5	38.8	37.9	42.2	Vertical	54	11.8	AV
14576.000	-34.0	40.2	38.1	44.3	Vertical	54	9.7	AV
15196.700	-34.6	40.4	38.8	44.6	Vertical	54	9.4	AV
15654.500	-33.8	41.0	37.7	44.9	Vertical	54	9.1	AV
16927.000	-32.3	42.2	37.9	47.8	Vertical	54	6.2	AV
17705.000	-31.7	43.1	36.3	47.7	Vertical	54	6.3	AV
14059.400	-34.9	39.8	38.7	43.6	Horizontal	54	10.4	AV
14855.000	-34.4	40.5	38.7	44.8	Horizontal	54	9.2	AV
15569.700	-33.9	40.8	38.0	44.9	Horizontal	54	9.1	AV
16419.700	-33.4	41.6	37.7	45.9	Horizontal	54	8.1	AV
16998.600	-32.0	42.2	37.6	47.8	Horizontal	54	6.2	AV
17850.800	-31.9	43.3	37.4	48.8	Horizontal	54	5.2	AV

Emission level (dBUV)=Read Value(dBUV/m) + Antenna Factor(dB)+ Cable Loss +preamp(dB)

30MHz-1GHz

Horizontal

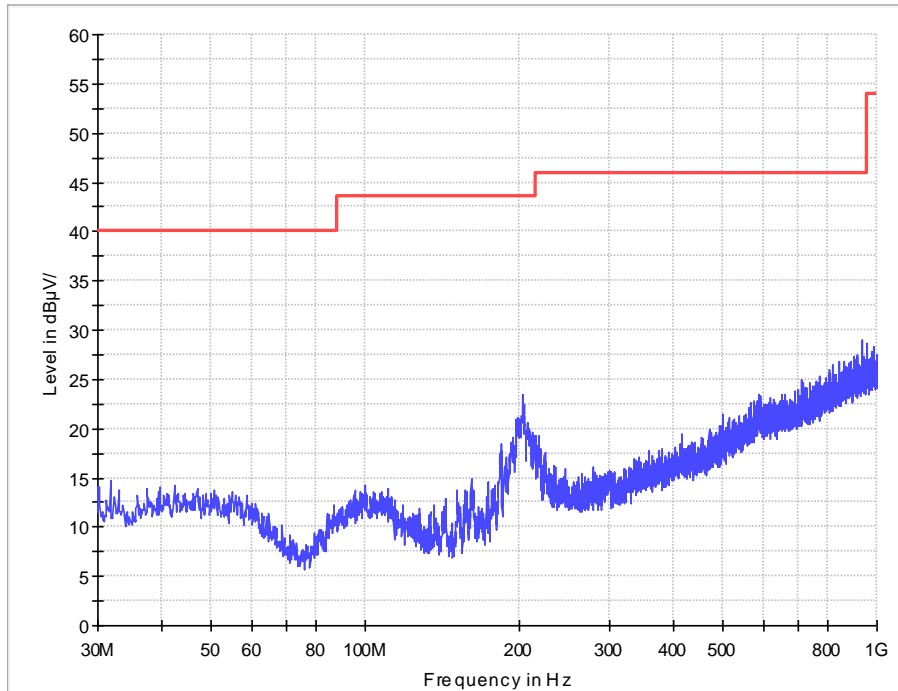

Vertical

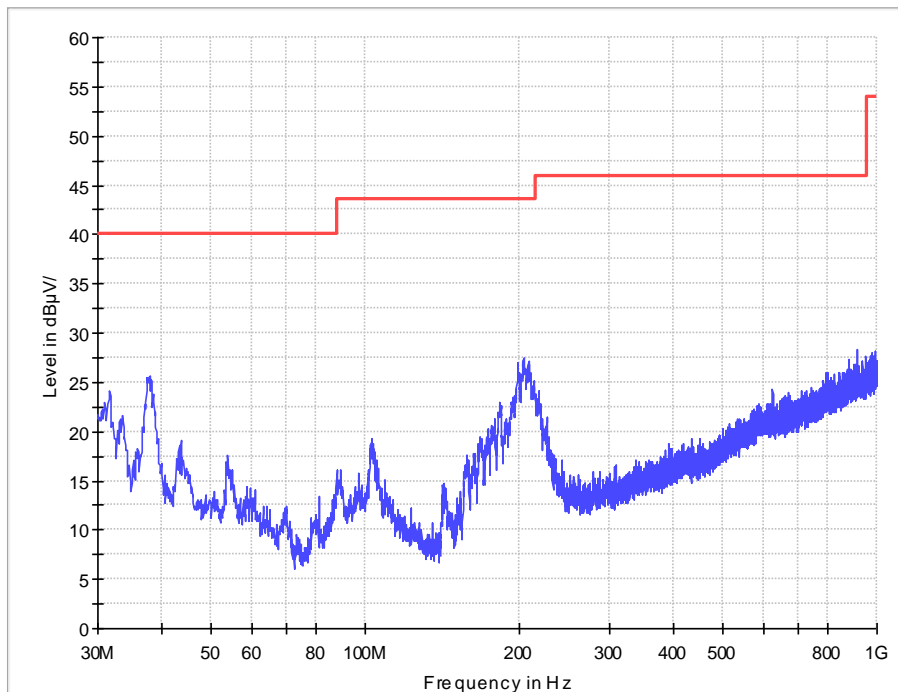

1GHz-18GHz

Horizontal

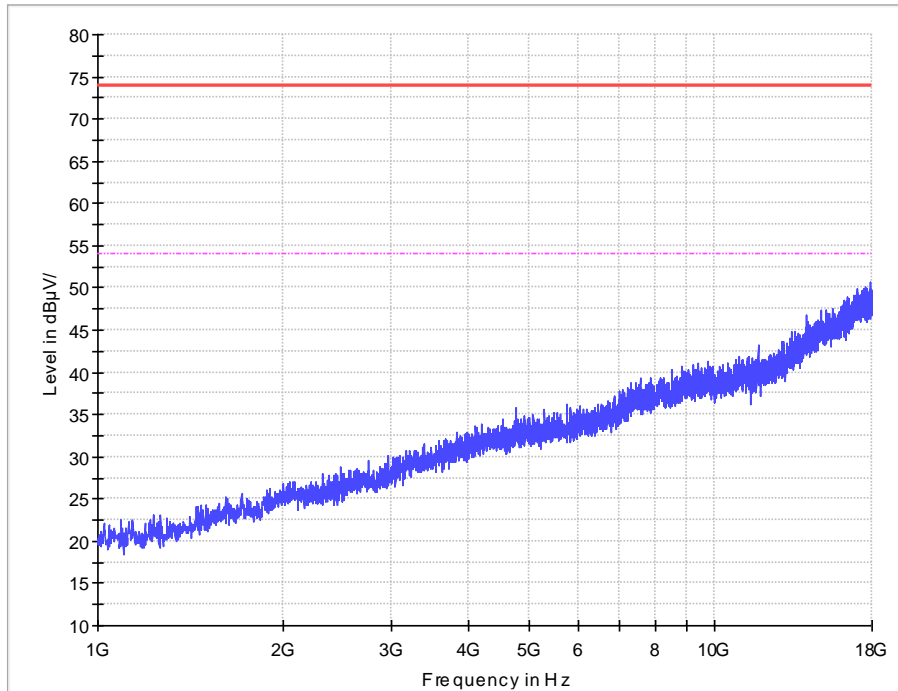

Vertical

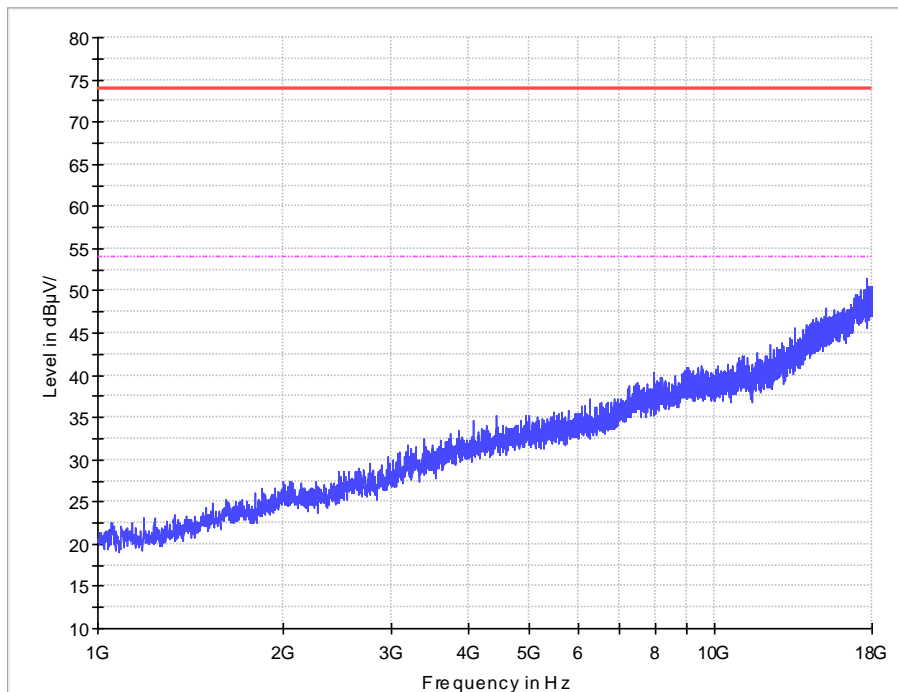

-----End of Report-----