

# FCC Radio Test Report

**FCC ID: 2BARQ-STONE620**

Test Report No.....: POC230904012-S001

Product(s) Name.....: Bluetooth Speaker

Model(s).....: Stone 620, YF25

Trade Mark.....: boAt

Applicant.....: Imagine Marketing Ltd.

Address.....: E Wing, 2nd Floor, Corporate Avenue AG Road Opp. Satellite  
Gazebo Andheri East, Mumbai, India

Receipt Date.....: 2023.09.04

Test Date.....: 2023.09.13~2023.09.20

Issued Date.....: 2023.09.21

Standards.....: 47 CFR FCC Part 15, Subpart C(Section 15.247)  
ANSI C63.10:2013

Testing Laboratory.....: Shenzhen Haiyun Standard Technical Co., Ltd.

Prepared By:	Checked By:	Approved By:	
Black Ding	Tim Zhang	Misue Su	
<i>Black Ding</i>	<i>Tim.zhang</i>	<i>Misue Su</i>	

# Table of Contents

<b>1 . SUMMARY OF TEST RESULTS</b>	<b>6</b>
1.1 TEST FACILITY	7
1.2 MEASUREMENT UNCERTAINTY	7
1.3 TEST ENVIRONMENT CONDITIONS	7
<b>2 . GENERAL INFORMATION</b>	<b>8</b>
2.1 GENERAL DESCRIPTION OF EUT	8
2.2 DESCRIPTION OF TEST MODES	9
2.3 PARAMETERS OF TEST SOFTWARE	10
2.4 SUPPORT UNITS	10
<b>3 . AC POWER LINE CONDUCTED EMISSIONS</b>	<b>11</b>
3.1 LIMIT	11
3.2 TEST PROCEDURE	11
3.3 DEVIATION FROM TEST STANDARD	11
3.4 TEST SETUP	12
3.5 EUT OPERATING CONDITIONS	12
3.6 TEST RESULTS	12
<b>4 . RADIATED EMISSIONS</b>	<b>13</b>
4.1 LIMIT	13
4.2 TEST PROCEDURE	14
4.3 DEVIATION FROM TEST STANDARD	15
4.4 TEST SETUP	15
4.5 EUT OPERATING CONDITIONS	16
4.6 TEST RESULTS - 9 KHZ TO 30 MHZ	16
4.7 TEST RESULTS - 30 MHZ TO 1000 MHZ	16
4.8 TEST RESULTS - ABOVE 1000 MHZ	16
<b>5 . NUMBER OF HOPPING FREQUENCY</b>	<b>17</b>
5.1 LIMIT	17
5.2 TEST PROCEDURE	17
5.3 DEVIATION FROM STANDARD	17
5.4 TEST SETUP	17
5.5 EUT OPERATION CONDITIONS	17
5.6 TEST RESULTS	17
<b>6 . AVERAGE TIME OF OCCUPANCY</b>	<b>18</b>
6.1 LIMIT	18

6.2 TEST PROCEDURE	18
6.3 DEVIATION FROM STANDARD	18
6.4 TEST SETUP	18
6.5 EUT OPERATION CONDITIONS	18
6.6 TEST RESULTS	18
<b>7 . HOPPING CHANNEL SEPARATION</b>	<b>19</b>
7.1 LIMIT	19
7.2 TEST PROCEDURE	19
7.3 DEVIATION FROM STANDARD	19
7.4 TEST SETUP	19
7.5 EUT OPERATION CONDITIONS	19
7.6 TEST RESULTS	19
<b>8 . BANDWIDTH</b>	<b>20</b>
8.1 LIMIT	20
8.2 TEST PROCEDURE	20
8.3 DEVIATION FROM STANDARD	20
8.4 TEST SETUP	20
8.5 EUT OPERATION CONDITIONS	20
8.6 TEST RESULTS	20
<b>9 . MAXIMUM OUTPUT POWER</b>	<b>21</b>
9.1 LIMIT	21
9.2 TEST PROCEDURE	21
9.3 DEVIATION FROM STANDARD	21
9.4 TEST SETUP	21
9.5 EUT OPERATION CONDITIONS	21
9.6 TEST RESULTS	21
<b>10 . CONDUCTED SPURIOUS EMISSION</b>	<b>22</b>
10.1 LIMIT	22
10.2 TEST PROCEDURE	22
10.3 DEVIATION FROM STANDARD	22
10.4 TEST SETUP	22
10.5 EUT OPERATION CONDITIONS	22
10.6 TEST RESULTS	22
<b>11 . MEASUREMENT INSTRUMENTS LIST</b>	<b>23</b>
<b>12 . ANTENNA REQUIREMENT</b>	<b>24</b>
<b>APPENDIX A - AC POWER LINE CONDUCTED EMISSIONS</b>	<b>25</b>



<b>APPENDIX B - RADIATED EMISSION - 9 KHZ TO 30 MHZ</b>	<b>28</b>
<b>APPENDIX C - RADIATED EMISSION - 30 MHZ TO 1000 MHZ</b>	<b>29</b>
<b>APPENDIX D - RADIATED EMISSION - ABOVE 1000 MHZ</b>	<b>32</b>
<b>APPENDIX E - NUMBER OF HOPPING FREQUENCY</b>	<b>43</b>
<b>APPENDIX F - AVERAGE TIME OF OCCUPANCY</b>	<b>46</b>
<b>APPENDIX G - HOPPING CHANNEL SEPARATION</b>	<b>57</b>
<b>APPENDIX H - BANDWIDTH</b>	<b>60</b>
<b>APPENDIX I - MAXIMUM OUTPUT POWER</b>	<b>71</b>
<b>APPENDIX J - CONDUCTED SPURIOUS EMISSION</b>	<b>77</b>
<b>APPENDIX K - DECLARATION FOR BLUETOOTH DEVICE</b>	<b>92</b>



### HISTORY OF THIS TEST REPORT

Original Report Issue Date: 2023.09.21

- No additional attachment
- Additional attachments were issued following record

Attachment No.	Issue Date	Description

## 1. SUMMARY OF TEST RESULTS

Test procedures according to the technical standard(s):

FCC CFR Title 47, Part 15, Subpart C				
Standard(s) Section	Test Item	Test Result	Judgment	Remark
15.207	AC Power Line Conducted Emissions	APPENDIX A	PASS	-----
15.247(d) 15.205(a) 15.209(a)	Radiated Emission	APPENDIX B APPENDIX C APPENDIX D	PASS	-----
15.247 (a)(1)(iii)	Number of Hopping Frequency	APPENDIX E	PASS	-----
15.247 (a)(1)(iii)	Average Time of Occupancy	APPENDIX F	PASS	-----
15.247(a)(1)	Hopping Channel Separation	APPENDIX G	PASS	-----
15.247(a)(1)	Bandwidth	APPENDIX H	PASS	-----
15.247(a)(1)	Maximum Output Power	APPENDIX I	PASS	-----
15.247(d)	Conducted Spurious Emission	APPENDIX J	PASS	-----
15.203	Antenna Requirement	-----	PASS	Note(2)

Note:

- (1) "N/A" denotes test is not applicable in this test report
- (2) The device what use a permanently attached antenna were considered sufficient to comply with the provisions of 15.203.

## 1.1 TEST FACILITY

Company:	Shenzhen Haiyun Standard Technical CO., Ltd.
Address:	No. 110-113, 115, 116, Block B, Jinyuan Business Building, Bao'an District, Shenzhen, China
CNAS Registration Number:	CNAS L18252
CAB identifier:	CN0145
A2LA Certificate Number:	6823.01
Telephone:	0755-26024411

## 1.2 MEASUREMENT UNCERTAINTY

ISO/IEC 17025 requires that an estimate of the measurement uncertainties associated with the emissions test results be included in the report. The measurement uncertainties given below are based on a 95% confidence level (based on a coverage factor ( $k=2$ ))

Uncertainty	
Parameter	Uncertainty
Occupied Channel Bandwidth	$\pm 143.88\text{kHz}$
Power Spectral Density	$\pm 0.743\text{dB}$
Conducted Spurious Emission	$\pm 1.328\text{dB}$
RF power conducted	$\pm 0.384\text{dB}$
Conducted emission(9kHz~30MHz) AC main	$\pm 2.72\text{dB}$
Radiated emission(9kHz~30MHz)	$\pm 2.66\text{dB}$
Radiated emission (30MHz~1GHz)	$\pm 4.62\text{dB}$
Radiated emission (1GHz~18GHz)	$\pm 4.86\text{dB}$
Radiated emission (18GHz~40GHz)	$\pm 3.80\text{dB}$

Note: Unless specifically mentioned, the uncertainty of measurement has not been taken into account to declare the compliance or non-compliance to the specification.

## 1.3 TEST ENVIRONMENT CONDITIONS

Test Item	Temperature	Humidity	Test Voltage	Tested By
AC Power Line Conducted Emissions	25°C	53%	AC 120V/60Hz	Albert Fan
Radiated Emissions-9 kHz to 30 MHz	24°C	51%	AC 120V/60Hz	Albert Fan
Radiated Emissions-30 MHz to 1000 MHz	24°C	51%	AC 120V/60Hz	Albert Fan
Radiated Emissions-Above 1000 MHz	24°C	51%	AC 120V/60Hz	Albert Fan
Bandwidth	24.5°C	52%	DC 3.7V	Jason Huang
Maximum Output Power	24.5°C	52%	DC 3.7V	Jason Huang
Conducted Spurious Emission	24.5°C	52%	DC 3.7V	Jason Huang
Number of Hopping Frequency	24.5°C	52%	DC 3.7V	Jason Huang
Average Time of Occupancy	24.5°C	52%	DC 3.7V	Jason Huang
Hopping Channel Separation	24.5°C	52%	DC 3.7V	Jason Huang

Note: Adapter supply voltage AC 120V/60Hz.

## 2. GENERAL INFORMATION

### 2.1 GENERAL DESCRIPTION OF EUT

Product Name	Bluetooth Speaker
Brand Name	boAt
Test Model	Stone 620
Series Model	YF25
Model Difference(s)	Only the color and model name are differences
Power Source	DC 5V from adapter or DC 3.7V from battery
Operation Frequency	2402 MHz ~ 2480 MHz
Modulation Type	GFSK, $\pi/4$ -DQPSK, 8-DPSK
Bit Rate of Transmitter	1Mbps, 2Mbps, 3Mbps
Max. Output Power	3Mbps: 2.35 dBm (0.0017 W)
Antenna gain	-0.58dBi
Antenna type	PCB antenna

Note:

1. For a more detailed features description, please refer to the manufacturer's specifications or the user's manual.

2. Channel List:

Channel	Frequency (MHz)	Channel	Frequency (MHz)	Channel	Frequency (MHz)
00	2402	27	2429	54	2456
01	2403	28	2430	55	2457
02	2404	29	2431	56	2458
03	2405	30	2432	57	2459
04	2406	31	2433	58	2460
05	2407	32	2434	59	2461
06	2408	33	2435	60	2462
07	2409	34	2436	61	2463
08	2410	35	2437	62	2464
09	2411	36	2438	63	2465
10	2412	37	2439	64	2466
11	2413	38	2440	65	2467
12	2414	39	2441	66	2468
13	2415	40	2442	67	2469
14	2416	41	2443	68	2470
15	2417	42	2444	69	2471
16	2418	43	2445	70	2472
17	2419	44	2446	71	2473
18	2420	45	2447	72	2474
19	2421	46	2448	73	2475
20	2422	47	2449	74	2476
21	2423	48	2450	75	2477
22	2424	49	2451	76	2478
23	2425	50	2452	77	2479
24	2426	51	2453	78	2480
25	2427	52	2454		
26	2428	53	2455		



## 2.2 DESCRIPTION OF TEST MODES

The test system was pre-tested based on the consideration of all possible combinations of EUT operation mode.

Pretest Mode	Description
Mode 1	TX Mode_1Mbps Channel 00/39/78
Mode 2	TX Mode_2Mbps Channel 00/39/78
Mode 3	TX Mode_3Mbps Channel 00/39/78
Mode 4	TX Mode_1Mbps Channel 00

Following mode(s) was (were) found to be the worst case(s) and selected for the final test.

<b>AC power line conducted emissions test</b>	
Final Test Mode	Description
Mode 4	TX Mode_1Mbps Channel 00

<b>Radiated emissions test - Below 1GHz</b>	
Final Test Mode	Description
Mode 4	TX Mode_1Mbps Channel 00

<b>Radiated emissions test - Above 1GHz</b>	
Final Test Mode	Description
Mode 1	TX Mode_1Mbps Channel 00/39/78
Mode 3	TX Mode_3Mbps Channel 00/39/78

<b>Maximum Output Power</b>	
Final Test Mode	Description
Mode 1	TX Mode_1Mbps Channel 00/39/78
Mode 2	TX Mode_2Mbps Channel 00/39/78
Mode 3	TX Mode_3Mbps Channel 00/39/78

<b>Other Conducted test</b>	
Final Test Mode	Description
Mode 1	TX Mode_1Mbps Channel 00/39/78
Mode 2	TX Mode_2Mbps Channel 00/39/78
Mode 3	TX Mode_3Mbps Channel 00/39/78

Note:

- (1) The measurements for Output Power were tested with DH1/3/5 during 1Mbps, 2Mbps and 3Mbps, the worst case were 1Mbps (DH5) and 3Mbps (DH5), only worst case were documented for other test items except Average Time of Occupancy.
- (2) For radiated emission above 1 GHz test, the spurious points of 1GHz~26.5GHz have been

pre-tested and in this report only recorded the worst case. The remaining spurious points are all below the limit value of 20dB.

- (3) This product has the mode of BT AFH, which was considered during testing. 800/20/X(X = 2 of DH1, X = 4 of DH3 or X = 6 of DH5) with 20, 10 or 6.67 hops per second in a channel, and then multiply 0.4\*20 (20 # of hopping). But this mode is not the worst case mode as duration of the packet is same, and this report only shows the worst case mode.
- (4) For AC power line conducted emissions and radiated spurious emissions below 1 GHz test, the 1Mbps Channel 00 are found to be the worst case and recorded.

## 2.3 PARAMETERS OF TEST SOFTWARE

During testing, channel & power controlling software provided by the customer was used to control the operating channel as well as the output power level.

Test Software Version	FCC_V2.24		
Frequency (MHz)	2402	2441	2480
1Mbps	default	default	default
2Mbps	default	default	default
3Mbps	default	default	default

## 2.4 SUPPORT UNITS

No.	Equipment	Manufacturer	Model	Series No
1	USB	Kingston	/	/
2	Mobile Phone	One plus	GM1900	/
3	Adaptore	Huawei	HW0501000	/

### 3. AC POWER LINE CONDUCTED EMISSIONS

#### 3.1 LIMIT

Frequency of Emission (MHz)	Limit (dB $\mu$ V)	
	Quasi-peak	Average
0.15 - 0.5	66 to 56*	56 to 46*
0.5 - 5.0	56	46
5.0 - 30.0	60	50

Note:

- (1) The tighter limit applies at the band edges.
- (2) The limit of " \* " marked band means the limitation decreases linearly with the logarithm of the frequency in the range.

#### 3.2 TEST PROCEDURE

- a. The EUT was placed 0.8 meters from the horizontal ground plane with EUT being connected to the power mains through a line impedance stabilization network (LISN). All other support equipment powered from additional LISN(s). The LISN provide 50 Ohm/ 50uH of coupling impedance for the measuring instrument.
- b. Interconnecting cables that hang closer than 40 cm to the ground plane shall be folded back and forth in the center forming a bundle 30 to 40 cm long.
- c. I/O cables that are not connected to a peripheral shall be bundled in the center. The end of the cable may be terminated, if required, using the correct terminating impedance. The overall length shall not exceed 1 m.
- d. LISN at least 80 cm from nearest part of EUT chassis.
- e. For the actual test configuration, please refer to the related Item –EUT Test Photos.

The following table is the setting of the receiver:

Receiver Parameters	Setting
Start Frequency	0.15 MHz
Stop Frequency	30 MHz
IF Bandwidth	9 kHz

#### 3.3 DEVIATION FROM TEST STANDARD

No deviation.

### 3.4 TEST SETUP

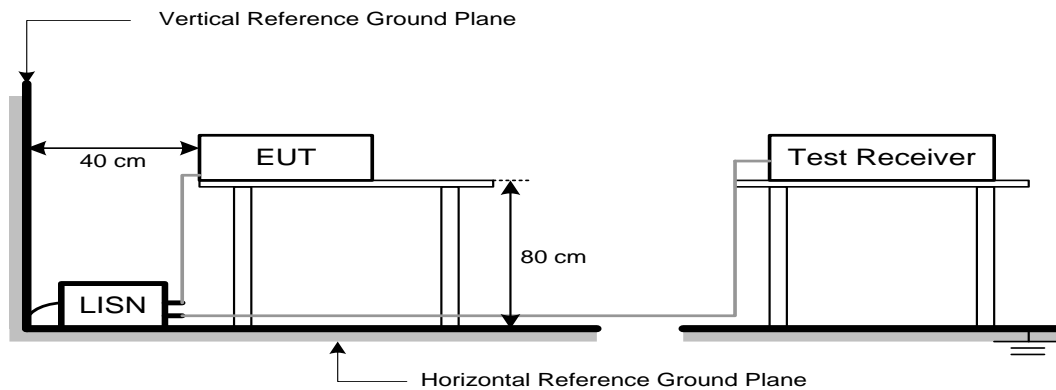

### 3.5 EUT OPERATING CONDITIONS

The EUT was configured for testing in a typical function (as a customer would normally use it), EUT was programmed to be in continuously transmitting data or hopping on mode.

### 3.6 TEST RESULTS

Please refer to the APPENDIX A.

Remark:

- (1) All readings are QP Mode value unless otherwise stated AVG in column of 『Note』 . If the QP Mode Measured value compliance with the QP Limits and lower than AVG Limits, the EUT shall be deemed to meet both QP & AVG Limits and then only QP Mode was measured, but AVG Mode didn't perform in this case, a “\*\*” marked in AVG Mode column of Interference Voltage Measured.
- (2) Measuring frequency range from 150 kHz to 30 MHz.

## 4. RADIATED EMISSIONS

### 4.1 LIMIT

In case the emission fall within the restricted band specified on 15.205(a), then the 15.209(a) limit in the table below has to be followed.

#### LIMITS OF RADIATED EMISSION MEASUREMENT (9 kHz-1000 MHz)

Frequency (MHz)	Field Strength (microvolts/meter)	Measurement Distance (meters)
0.009-0.490	2400/F(kHz)	300
0.490-1.705	24000/F(kHz)	30
1.705-30.0	30	30
30-88	100	3
88-216	150	3
216-960	200	3
Above 960	500	3

#### LIMITS OF RADIATED EMISSION MEASUREMENT (Above 1000 MHz)

Frequency (MHz)	(dBuV/m at 3 m)	
	Peak	Average
Above 1000	74	54

Note:

- (1) The limit for radiated test was performed according to FCC CFR Title 47, Part 15, Subpart C.
- (2) The tighter limit applies at the band edges.
- (3) Emission level (dBuV/m)=20log Emission level (uV/m).

## 4.2 TEST PROCEDURE

- a. The measuring distance of 3 m shall be used for measurements. The EUT was placed on the top of a rotating table 0.8 meter above the ground at a 3 meter semi-anechoic chamber. The table was rotated 360 degrees to determine the position of the highest radiation.(below 1 GHz)
- b. The measuring distance of 3 m shall be used for measurements. The EUT was placed on the top of a rotating table 1.5 meter above the ground at a 3 meter semi-anechoic chamber. The table was rotated 360 degrees to determine the position of the highest radiation.(above 1 GHz)
- c. The height of the equipment or of the substitution antenna shall be 0.8m or 1.5m; the height of the test antenna shall vary between 1 m to 4 m. Both horizontal and vertical polarizations of the antenna are set to make the measurement.
- d. For each suspected emission, the EUT was arranged to its worst case and then the antenna was tuned to heights find the maximum reading (used Bore sight function).
- e. The receiver system was set to peak and average detect function and specified bandwidth with maximum hold mode when the test frequency is above 1 GHz.
- f. The initial step in collecting radiated emission data is a receiver peak detector mode pre-scanning the measurement frequency range. Significant peaks are then marked and then Quasi Peak detector mode re-measured.
- g. All readings are Peak unless otherwise stated QP in column of Note. Peak denotes that the Peak reading compliance with the QP Limits and then QP Mode measurement didn't perform. (below 1 GHz)
- h. All readings are Peak Mode value unless otherwise stated AVG in column of Note. If the Peak Mode Measured value compliance with the Peak Limits and lower than AVG Limits, the EUT shall be deemed to meet both Peak & AVG Limits and then only Peak Mode was measured, but AVG Mode didn't perform. (above 1 GHz)
- i. For the actual test configuration, please refer to the related Item –EUT Test Photos.

The following table is the setting of the receiver:

Spectrum Parameters	Setting
Start ~ Stop Frequency	9 kHz~150 kHz for RBW 200 Hz
Start ~ Stop Frequency	0.15 MHz~30 MHz for RBW 9 kHz
Start ~ Stop Frequency	30 MHz~1000 MHz for RBW 100 kHz

Spectrum Parameters	Setting
Start Frequency	1000 MHz
Stop Frequency	10th carrier harmonic
RBW / VBW (Emission in restricted band)	1 MHz / 3 MHz for PK value 1 MHz / 1/T Hz for AVG value

Spectrum Parameters	Setting
Start ~ Stop Frequency	9 kHz~90 kHz for PK/AVG detector
Start ~ Stop Frequency	90 kHz~110 kHz for QP detector
Start ~ Stop Frequency	110 kHz~490 kHz for PK/AVG detector
Start ~ Stop Frequency	490 kHz~30 MHz for QP detector
Start ~ Stop Frequency	30 MHz~1000 MHz for QP detector
Start ~ Stop Frequency	1 GHz~26.5 GHz for PK/AVG detector

### 4.3 DEVIATION FROM TEST STANDARD

No deviation.

### 4.4 TEST SETUP

#### 9 kHz to 30 MHz

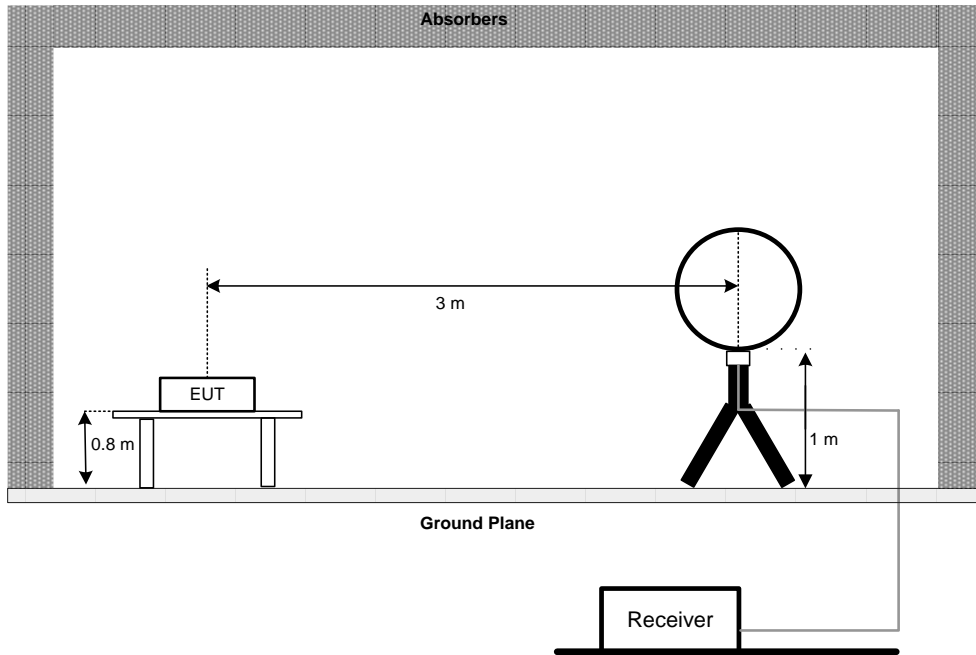

#### 30 MHz to 1 GHz

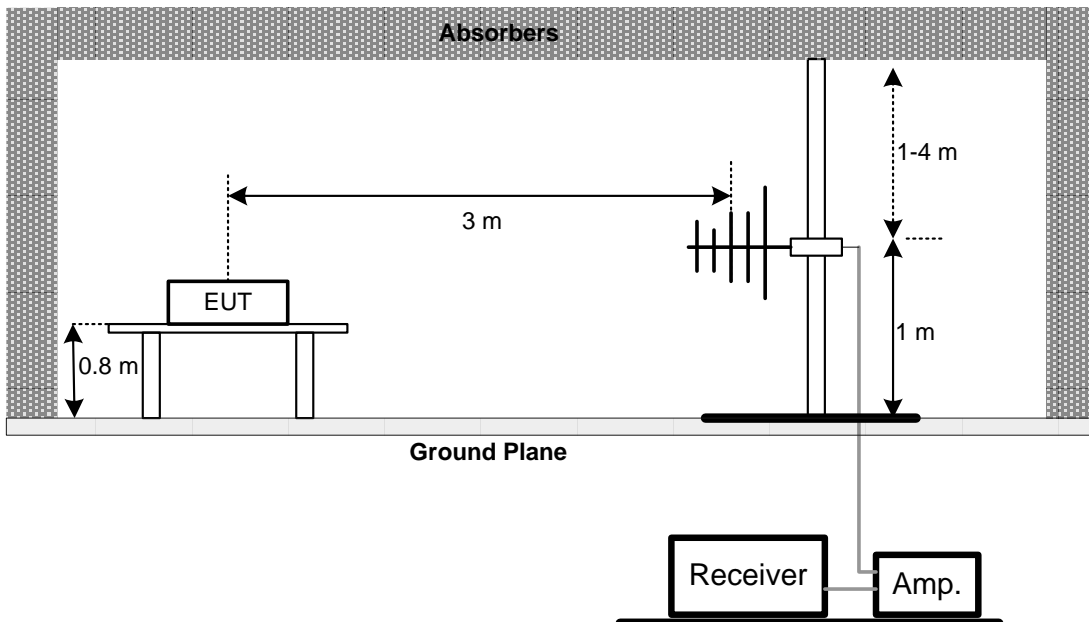

### Above 1 GHz

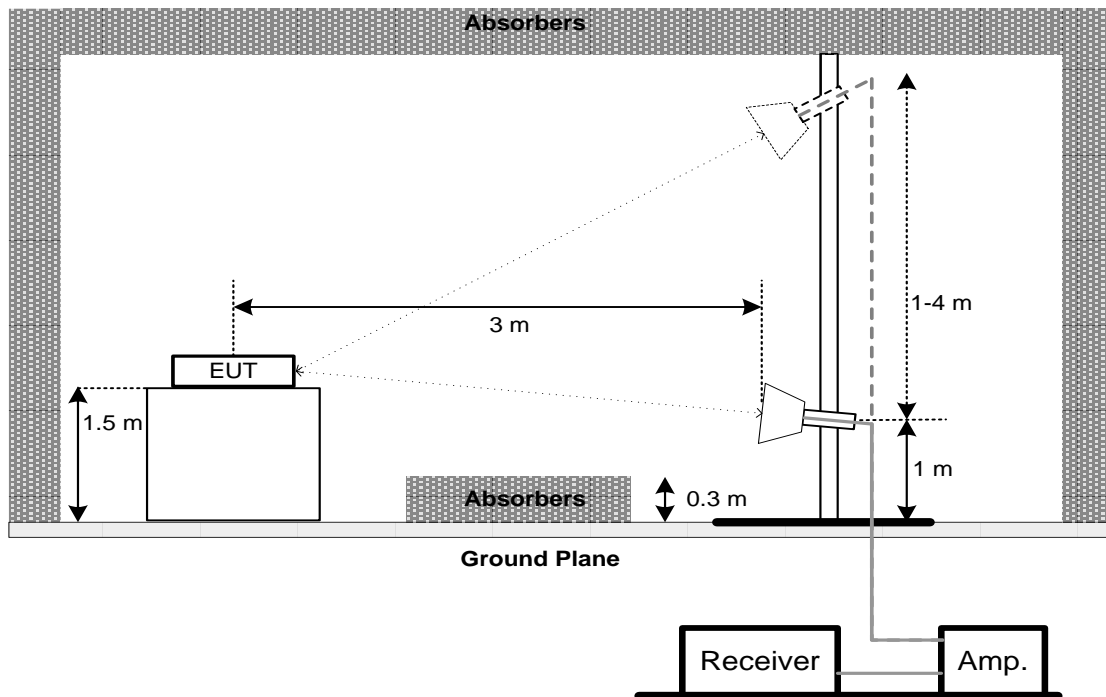

#### 4.5 EUT OPERATING CONDITIONS

The EUT was programmed to be in continuously transmitting mode.

#### 4.6 TEST RESULTS - 9 kHz TO 30 MHz

Please refer to the APPENDIX B.

Remark:

- (1) Distance extrapolation factor =  $40 \log(\text{specific distance} / \text{test distance})$  (dB).
- (2) Limit line = specific limits (dBuV) + distance extrapolation factor.

#### 4.7 TEST RESULTS - 30 MHz TO 1000 MHz

Please refer to the APPENDIX C.

#### 4.8 TEST RESULTS - ABOVE 1000 MHz

Please refer to the APPENDIX D.

Remark:

- (1) No limit: This is fundamental signal, the judgment is not applicable.  
For fundamental signal judgment was referred to Peak output test.



## 5. NUMBER OF HOPPING FREQUENCY

### 5.1 LIMIT

Section	Test Item	Limit
FCC 15.247(a)(1)(iii)	Number of Hopping Frequency	15

### 5.2 TEST PROCEDURE

- The EUT was directly connected to the tonscend test system and antenna output port as show in the block diagram below.
- The following table is the setting of the spectrum analyzer:

Spectrum Parameters	Setting
Span Frequency	> Operating Frequency Range
RBW	300 kHz
VBW	300 kHz
Detector	Peak
Trace	Max Hold
Sweep Time	Auto

### 5.3 DEVIATION FROM STANDARD

No deviation.

### 5.4 TEST SETUP

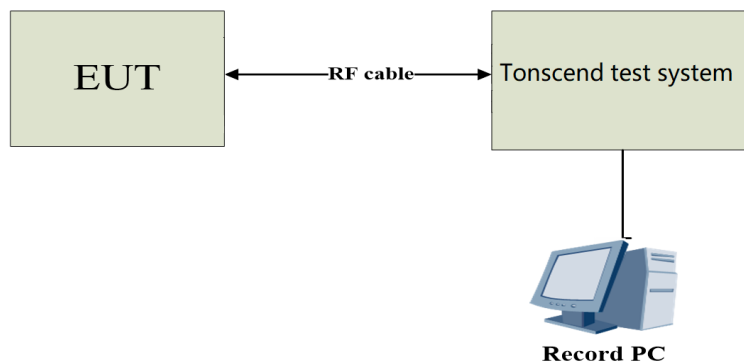

### 5.5 EUT OPERATION CONDITIONS

The EUT was programmed to be in continuously transmitting mode.

### 5.6 TEST RESULTS

Please refer to the APPENDIX E.

## 6. AVERAGE TIME OF OCCUPANCY

### 6.1 LIMIT

Section	Test Item	Limit
FCC 15.247(a)(1)(iii)	Average Time of Occupancy	0.4sec

### 6.2 TEST PROCEDURE

- Set the EUT for DH1, DH3 and DH5 packet transmitting.
- Measure the maximum time duration of one single pulse.
- DH1 Packet permit maximum  $1600 / 79 / 2 = 10.12$  hops per second in each channel (1 time slot TX, 1 time slot RX). So, the dwell time is the time duration of the pulse times  $10.12 \times 31.6 = 320$  within 31.6 seconds.
- DH3 Packet permit maximum  $1600 / 79 / 4 = 5.06$  hops per second in each channel (3 time slots TX, 1 time slot RX). So, the dwell time is the time duration of the pulse times  $5.06 \times 31.6 = 160$  within 31.6 seconds.
- DH5 Packet permit maximum  $1600 / 79 / 6 = 3.37$  hops per second in each channel (5 time slots TX, 1 time slot RX). So, the dwell time is the time duration of the pulse times  $3.37 \times 31.6 = 106.6$  within 31.6 seconds.
- The EUT was directly connected to the tonscend test system and antenna output port as show in the block diagram below.
- The following table is the setting of the spectrum analyzer:

Spectrum Parameters	Setting
Span Frequency	0 MHz
RBW	1 MHz
VBW	1 MHz
Detector	Peak
Trace	Max Hold
Sweep Time	As necessary to capture the entire dwell time per hopping channel

### 6.3 DEVIATION FROM STANDARD

No deviation.

### 6.4 TEST SETUP

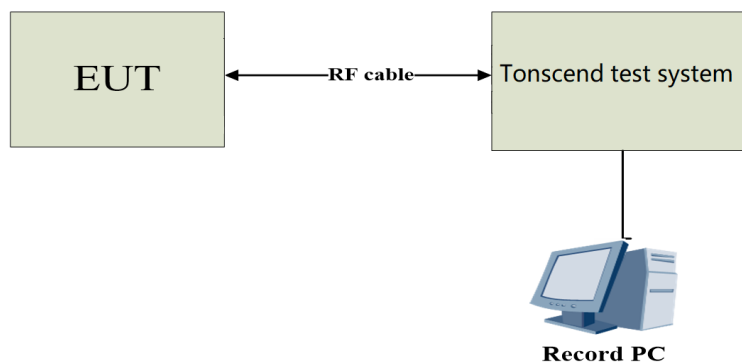

### 6.5 EUT OPERATION CONDITIONS

The EUT was programmed to be in continuously transmitting mode.

### 6.6 TEST RESULTS

Please refer to the APPENDIX F.

## 7. HOPPING CHANNEL SEPARATION

### 7.1 LIMIT

Frequency hopping systems operating in the 2400-2483.5 MHz band may have hopping channel carrier frequencies that are separated by 25 kHz or two-thirds of the 20 dB bandwidth of the hopping channel, whichever is greater, provided the systems operate with an output power no greater than 125 mW.

### 7.2 TEST PROCEDURE

- The EUT was directly connected to the tonskend test system and antenna output port as show in the block diagram below.
- The following table is the setting of the spectrum analyzer:

Spectrum Parameters	Setting
Span Frequency	Wide enough to capture the peaks of two adjacent channels
RBW	30 kHz
VBW	100 kHz
Detector	Peak
Trace	Max Hold
Sweep Time	Auto

### 7.3 DEVIATION FROM STANDARD

No deviation.

### 7.4 TEST SETUP

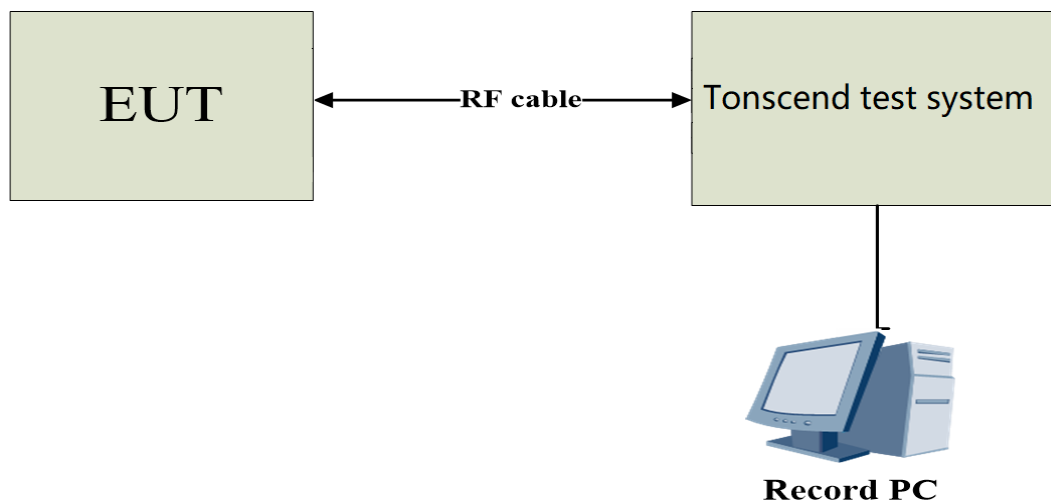

### 7.5 EUT OPERATION CONDITIONS

The EUT was programmed to be in continuously transmitting mode.

### 7.6 TEST RESULTS

Please refer to the APPENDIX G.

## 8. BANDWIDTH

### 8.1 LIMIT

Section	Test Item
FCC 15.247(a)(1)	Bandwidth

### 8.2 TEST PROCEDURE

- The EUT was directly connected to the tonscend test system and antenna output port as show in the block diagram below.
- The following table is the setting of the spectrum analyzer:

Spectrum Parameters	Setting
Span Frequency	> Measurement Bandwidth
RBW	30 kHz
VBW	100 kHz
Detector	Peak
Trace	Max Hold
Sweep Time	Auto

### 8.3 DEVIATION FROM STANDARD

No deviation.

### 8.4 TEST SETUP

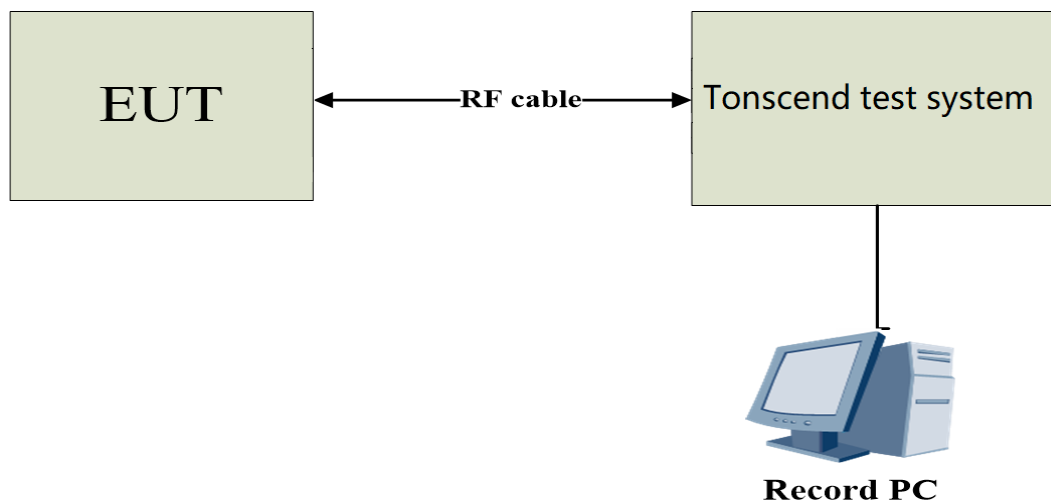

### 8.5 EUT OPERATION CONDITIONS

The EUT was programmed to be in continuously transmitting mode.

### 8.6 TEST RESULTS

Please refer to the APPENDIX H.

## 9. MAXIMUM OUTPUT POWER

### 9.1 LIMIT

Section	Test Item	Limit
FCC 15.247(a)(1)	Maximum Output Power	0.1250 Watt or 20.97 dBm

Note: Frequency hopping systems operating in the 2400-2483.5 MHz band may have hopping channel carrier frequencies that are separated by 25 kHz or two-thirds of the 20 dB bandwidth of the hopping channel, whichever is greater, provided the systems operate with an output power no greater than 125 mW.

### 9.2 TEST PROCEDURE

- The EUT was directly connected to the tonscond test system and antenna output port as show in the block diagram below.
- The following table is the setting of the spectrum analyzer:

Spectrum Parameters	Setting
Span Frequency	Approximately five times the 20 dB bandwidth, centered on a hopping channel.
RBW	3 MHz
VBW	8 MHz
Detector	Peak
Trace	Max Hold
Sweep Time	Auto

### 9.3 DEVIATION FROM STANDARD

No deviation.

### 9.4 TEST SETUP

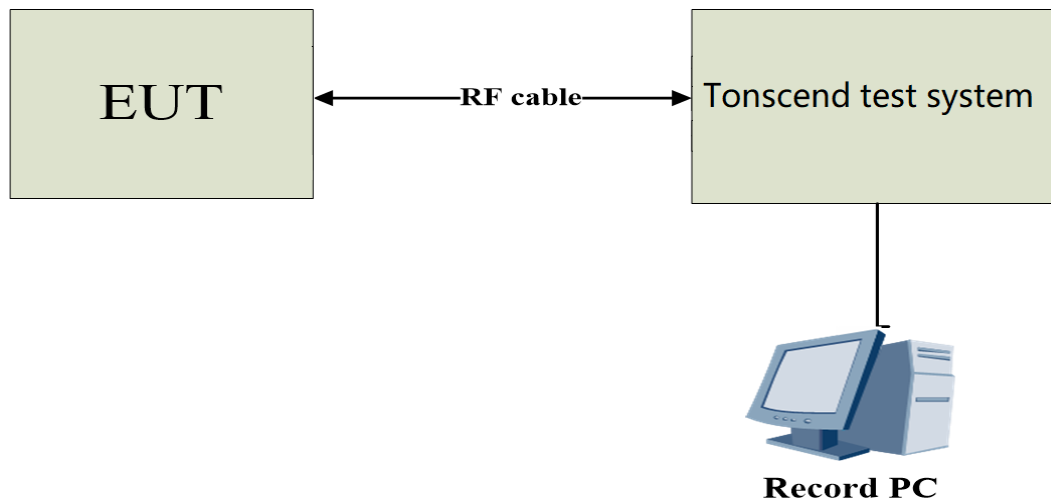

### 9.5 EUT OPERATION CONDITIONS

The EUT was programmed to be in continuously transmitting mode.

### 9.6 TEST RESULTS

Please refer to the APPENDIX I.

## 10. CONDUCTED SPURIOUS EMISSION

### 10.1 LIMIT

In any 100 kHz bandwidth outside the frequency band in which the spread spectrum or digitally modulated intentional radiator is operating, the radio frequency power that is produced by the intentional radiator shall be at least 20 dB below that in the 100 kHz bandwidth within the band that contains the highest level of the desired power, based on either an RF conducted or a radiated measurement, provided the transmitter demonstrates compliance with the peak Output Power limits. If the transmitter complies with the Output Power limits based on the use of RMS averaging over a time interval, as permitted under paragraph (b)(3) of this section, the attenuation required under this paragraph shall be 30 dB instead of 20 dB. Attenuation below the general limits specified in Section 15.209(a) is not required.

### 10.2 TEST PROCEDURE

- a. The EUT was directly connected to the tonscend test system and antenna output port as show in the block diagram below.
- b. The following table is the setting of the spectrum analyzer:

Spectrum Parameters	Setting
Start Frequency	30 MHz
Stop Frequency	26.5 GHz
RBW	100 kHz
VBW	100 kHz
Detector	Peak
Trace	Max Hold
Sweep Time	Auto

### 10.3 DEVIATION FROM STANDARD

No deviation.

### 10.4 TEST SETUP

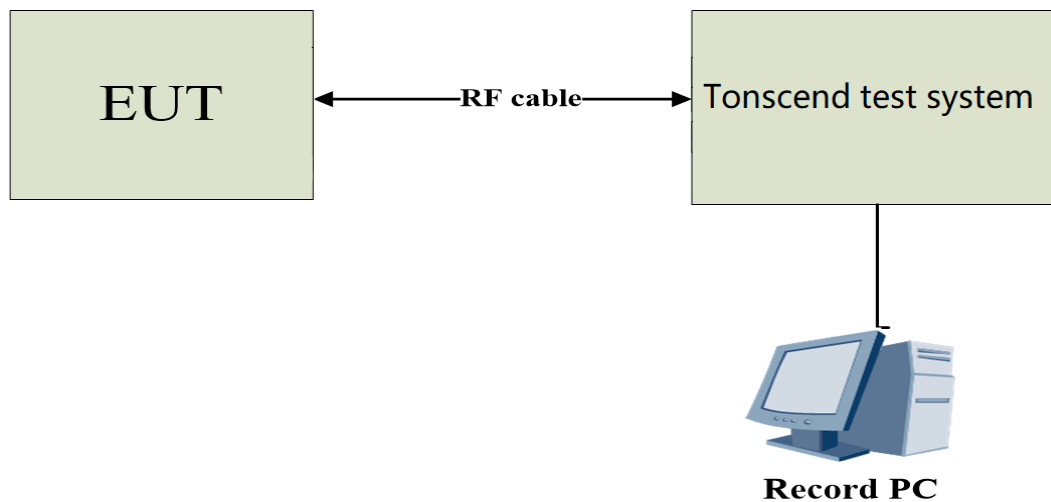

### 10.5 EUT OPERATION CONDITIONS

The EUT was programmed to be in continuously transmitting mode.

### 10.6 TEST RESULTS

Please refer to the APPENDIX J.

### 11. MEASUREMENT INSTRUMENTS LIST

Radiated Emissions						
No.	Equipment	Manufacturer	Type No.	Serial No.	Cal. date (yyyy/mm/dd)	Cal. Due date (yyyy/mm/dd)
1	Test receiver	Rohde&Schwarz	ESU	100184	2023/5/3	2024/5/2
2	Horn Antenna	Schwarzbeck	BBHA 9120 D	9120D-127 3	2023/4/23	2024/4/22
3	Low frequency amplifier	Unknown	LNA 0920N	2014	2023/5/3	2024/5/2
4	High frequency amplifier	Schwarzbeck	BBV 9718	284	2023/5/3	2024/5/2
5	Loop Antenna	Schwarzbeck	FMZB151 9B	00029	2022/7/4	2025/7/3
6	Log periodic antenna	Schwarzbeck	VULB 9168	1151	2023/4/23	2024/4/22
7	Horn Antenna	Schwarzbeck	BBHA 9120 D	9120D-127 3	2022/5/5	2025/5/4
8	Horn Antenna	Schwarzbeck	BBHA 9170	9170#685	2022/7/4	2025/7/3
9	Temp&Humidity Recorder	Meideshi	JR900	/	2023/5/3	2024/5/2
10	RF cable(966 chamber)9kHz- 1GHz	Unknown	Unknown	Unknown	2023/5/3	2024/5/2
11	RF cable(966 chamber)1GHz -18GHz	Unknown	Unknown	Unknown	2023/5/3	2024/5/2
12	RF cable(966 chamber)18GH z-40GHz	Unknown	Unknown	Unknown	2023/5/3	2024/5/2
13	Test software	Farad Technology Co., Ltd	EZ-EMC	/	/	/
Conducted Emission						
1	Test receiver	Rohde&Schwarz	ESCI	100718	2023/5/3	2024/5/2
2	LISN	Rohde&Schwarz	ENV216	100075	2023/5/3	2024/5/2
3	Pulse limiter	Rohde&Schwarz	ESH3-Z2	102299	2023/5/3	2024/5/2
4	RF cable (9kHz-30MHz)	Unknown	Unknown	Unknown	2023/5/3	2024/5/2
5	Test software	Farad Technology Co., Ltd	EZ-EMC	/	/	/
RF conducted Emissions						
1	MXA Signal Analyzer	Keysight	N9021B	MY600801 69	2023/4/23	2024/4/22
2	RF Control Unit	dsusoft	JS0806-2	21G80604 49	2023/4/23	2024/4/22
3	power supply unit	dsusoft	JS0806-4 ADC	N/A	2023/4/23	2024/4/22
4	VXG Signal Generator	Keysight	M9384B	MY612707 87	2023/4/23	2024/4/22
5	EXG Analog Signal Generator	Keysight	N5173B	MY591012 82	2023/4/23	2024/4/22
6	Test software	dsusoft	JS1120-3	/	/	/



## 12. ANTENNA REQUIREMENT

Test standard: FCC part 15.203

According to the manufacturer declared, the EUT has PCB antenna, the antenna gain is -0.58dBi and the antenna connector is designed with permanent attachment and no consideration of replacement.

Therefore the EUT is considered sufficient to comply with the provision.

Refer to EUT Photo for further details.





## **APPENDIX A - AC POWER LINE CONDUCTED EMISSIONS**

Test Mode	TX Mode_1Mbps Channel 00	Phase	Line
-----------	--------------------------	-------	------

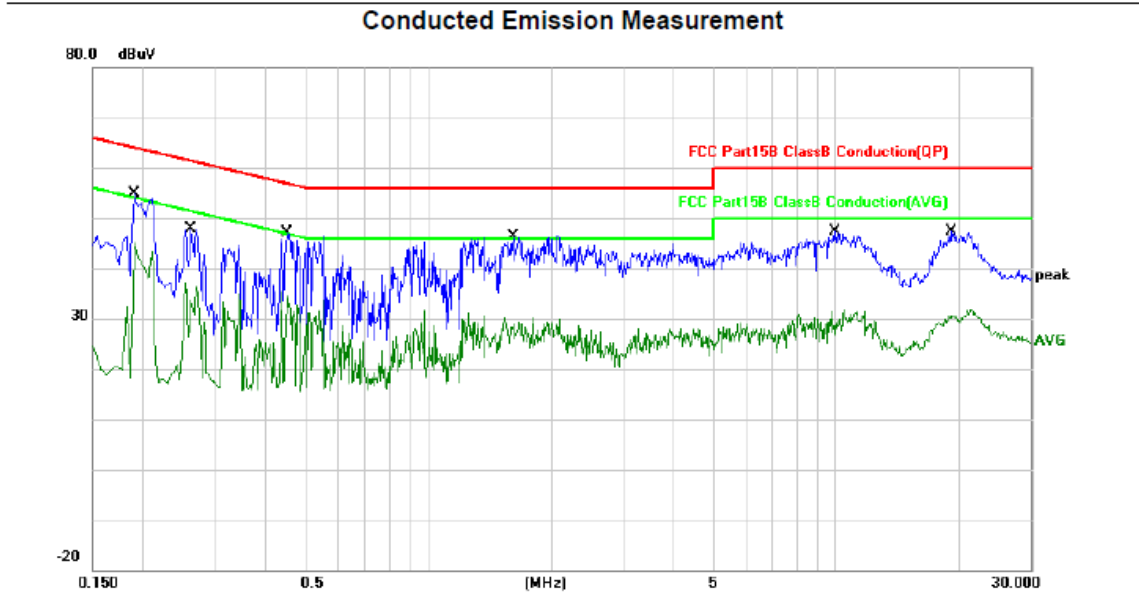

No.	Mk.	Freq.	Reading Level	Correct Factor	Measurement	Limit	Over	Detector	Comment
		MHz	dBuV	dB	dBuV	dBuV	dB		
1	*	0.1900	32.49	19.88	52.37	64.04	-11.67	QP	
2		0.1900	18.78	19.88	38.66	54.04	-15.38	AVG	
3		0.2620	24.81	19.88	44.69	61.37	-16.68	QP	
4		0.2620	11.30	19.88	31.18	51.37	-20.19	AVG	
5		0.4500	23.81	19.88	43.69	56.88	-13.19	QP	
6		0.4500	7.99	19.88	27.87	46.88	-19.01	AVG	
7		1.6140	22.25	19.90	42.15	56.00	-13.85	QP	
8		1.6140	5.64	19.90	25.54	46.00	-20.46	AVG	
9		9.9100	18.32	19.96	38.28	60.00	-21.72	QP	
10		9.9100	5.03	19.96	24.99	50.00	-25.01	AVG	
11		19.1100	18.93	20.05	38.98	60.00	-21.02	QP	
12		19.1100	7.71	20.05	27.76	50.00	-22.24	AVG	

**REMARKS:**

- (1) Measurement Value = Reading Level + Correct Factor.
- (2) Margin Level = Measurement Value - Limit Value.

Test Mode	TX Mode_1Mbps Channel 00	Phase	Neutral
-----------	--------------------------	-------	---------

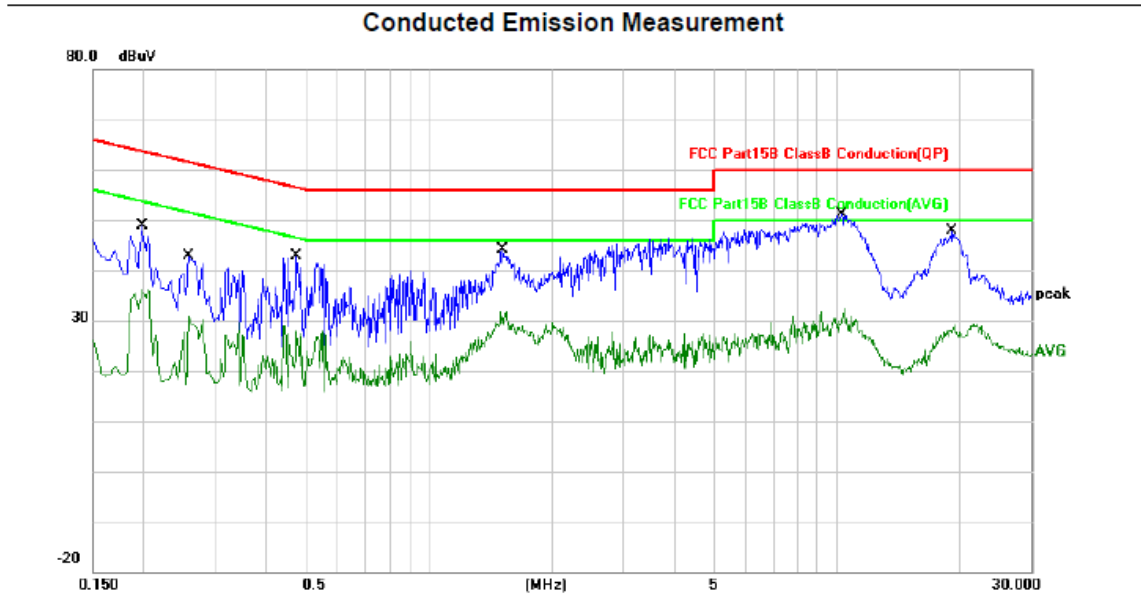

No.	Mk.	Freq.	Reading Level	Correct Factor	Measurement	Limit	Over	Detector	Comment
		MHz	dBuV	dB	dBuV	dBuV	dB		
1		0.1980	23.24	19.88	43.12	63.69	-20.57	QP	
2		0.1980	12.97	19.88	32.85	53.69	-20.84	AVG	
3		0.2580	17.22	19.88	37.10	61.50	-24.40	QP	
4		0.2580	6.32	19.88	26.20	51.50	-25.30	AVG	
5		0.4740	15.53	19.88	35.41	56.44	-21.03	QP	
6		0.4740	1.99	19.88	21.87	46.44	-24.57	AVG	
7	*	1.5140	20.38	19.90	40.28	56.00	-15.72	QP	
8		1.5140	9.14	19.90	29.04	46.00	-16.96	AVG	
9		10.2820	21.64	19.96	41.60	60.00	-18.40	QP	
10		10.2820	4.79	19.96	24.75	50.00	-25.25	AVG	
11		19.1460	20.24	20.05	40.29	60.00	-19.71	QP	
12		19.1460	4.32	20.05	24.37	50.00	-25.63	AVG	

**REMARKS:**

(1) Measurement Value = Reading Level + Correct Factor.

(2) Margin Level = Measurement Value - Limit Value.

## **APPENDIX B - RADIATED EMISSION - 9 KHZ TO 30 MHZ**

The low frequency, which started from 9 kHz to 30MHz, was pre-scanned and the result which was 20dB lower than the limit line was not reported.

There is a comparison data of both open-field test site and semi-Anechoic chamber, and the result came out very similar.



## **APPENDIX C - RADIATED EMISSION - 30 MHZ TO 1000 MHZ**

Test Mode	TX Mode_1Mbps Channel 00	Polarization	Vertical
-----------	--------------------------	--------------	----------

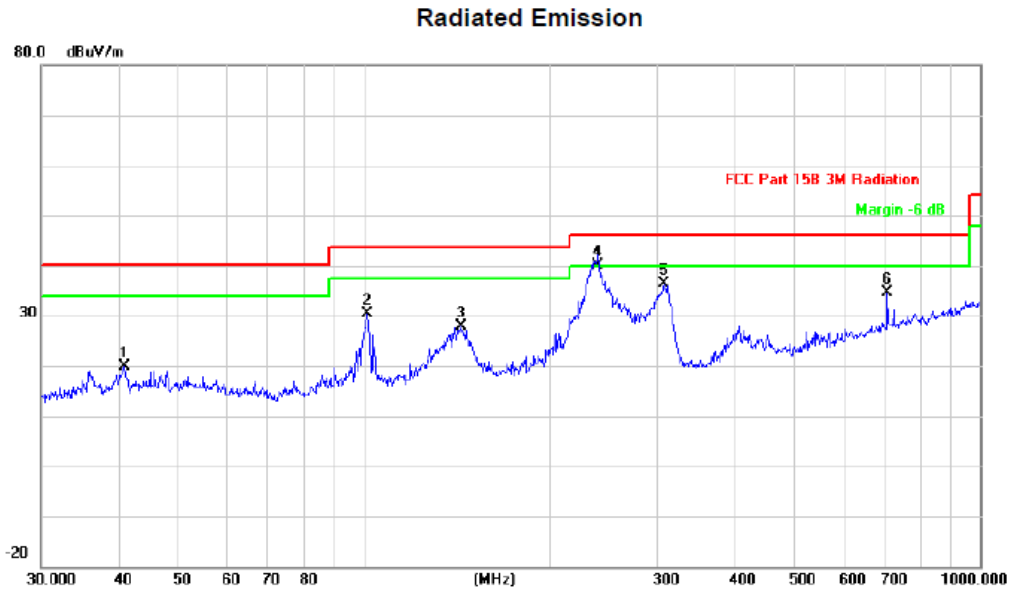

No.	Mk.	Freq.	Reading Level	Correct Factor	Measurement	Limit	Over	Antenna Height	Table Degree	
		MHz	dBuV	dB/m	dBuV/m	dBuV/m	dB	cm	degree	Comment
1		40.8444	30.53	-10.62	19.91	40.00	-20.09			peak
2		101.2883	43.79	-13.33	30.46	43.50	-13.04			peak
3		143.8291	37.54	-9.63	27.91	43.50	-15.59			peak
4	*	239.9873	50.03	-9.84	40.19	46.00	-5.81			QP
5		306.7536	44.42	-8.09	36.33	46.00	-9.67			peak
6		706.6997	33.52	1.04	34.56	46.00	-11.44			peak

**REMARKS:**

- (1) Measurement Value = Reading Level + Correct Factor.  
 (2) Margin Level = Measurement Value - Limit Value.

Test Mode	TX Mode_1Mbps Channel 00	Polarization	Horizontal
-----------	--------------------------	--------------	------------

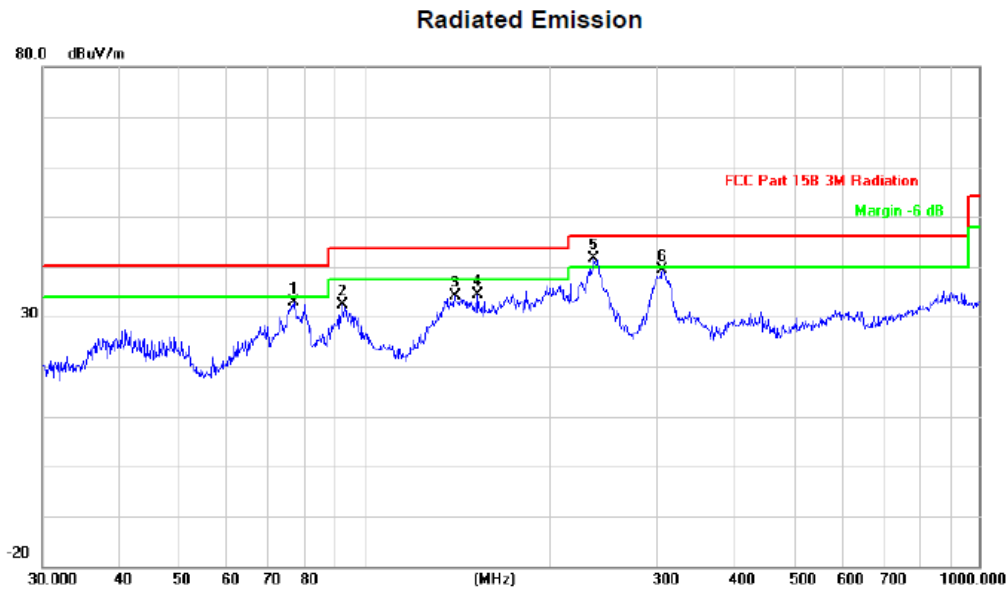

No.	Mk.	Freq.	Reading Level	Correct Factor	Measurement	Limit	Over	Antenna Height	Table Degree	
		MHz	dBuV	dB/m	dBuV/m	dBuV/m	dB	cm	degree	Comment
1		77.0502	46.76	-13.94	32.82	40.00	-7.18	peak		
2		92.4624	46.72	-14.42	32.30	43.50	-11.20	peak		
3		140.3420	43.86	-9.71	34.15	43.50	-9.35	peak		
4		153.2000	43.92	-9.42	34.50	43.50	-9.00	peak		
5	*	236.6447	51.62	-9.98	41.64	46.00	-4.36	peak		
6		305.6800	47.40	-8.13	39.27	46.00	-6.73	peak		

**REMARKS:**

- (1) Measurement Value = Reading Level + Correct Factor.
- (2) Margin Level = Measurement Value - Limit Value.



## **APPENDIX D - RADIATED EMISSION - ABOVE 1000 MHZ**



Test Mode	TX Mode_1Mbps Channel 00	Polarization	Vertical
-----------	--------------------------	--------------	----------

### Radiated Emission

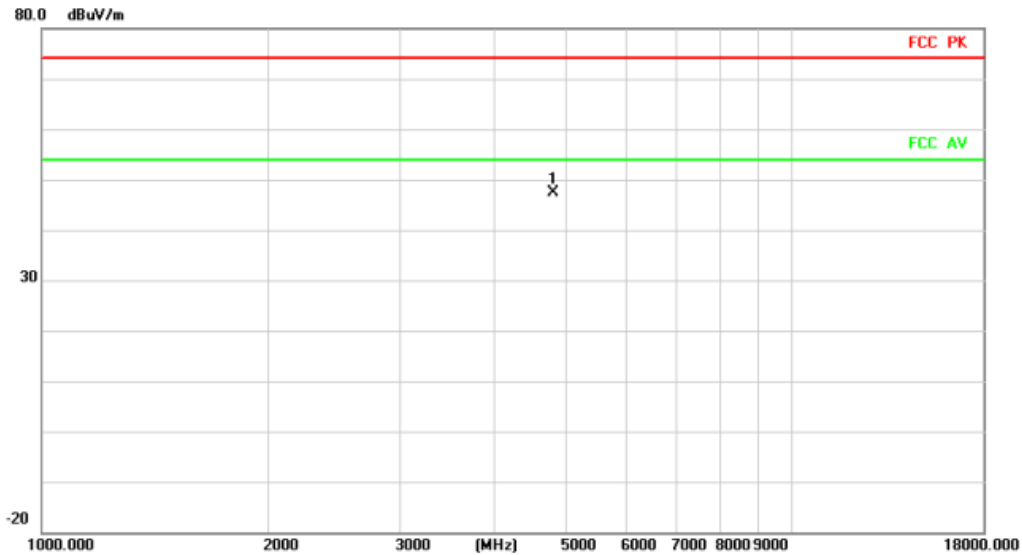

No.	Mk.	Freq.	Reading Level	Correct Factor	Measurement	Limit	Over	Antenna Height	Table Degree	
		MHz	dBuV	dB/m	dBuV/m	dBuV/m	dB	cm	degree	Comment
1	*	4804.000	49.25	-1.99	47.26	74.00	-26.74			peak

### Radiated Emission

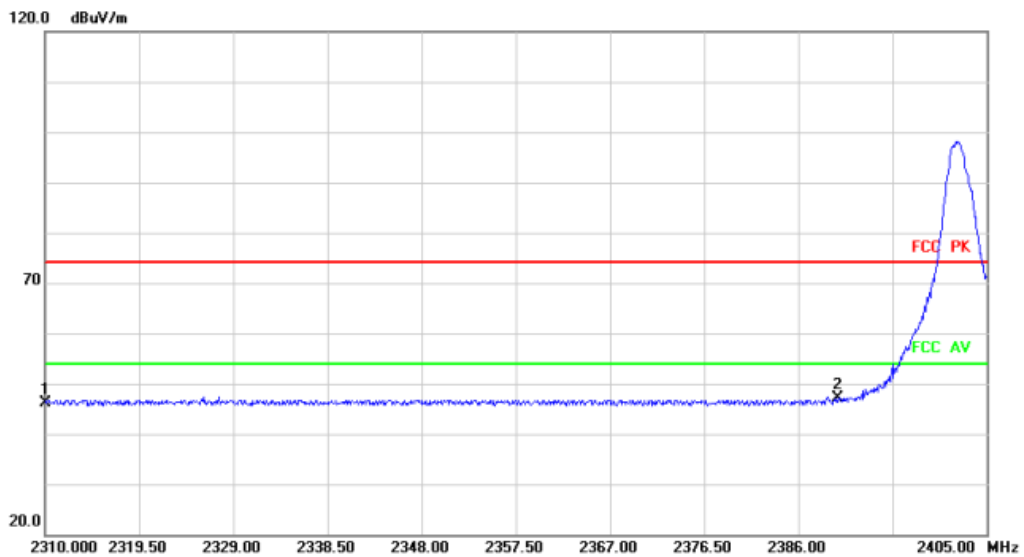

No.	Mk.	Freq.	Reading Level	Correct Factor	Measurement	Limit	Over	Antenna Height	Table Degree	
		MHz	dBuV	dB/m	dBuV/m	dBuV/m	dB	cm	degree	Comment
1		2310.000	45.89	0.19	46.08	74.00	-27.92			peak
2	*	2390.000	46.80	0.41	47.21	74.00	-26.79			peak

Test Mode	TX Mode_1Mbps Channel 00	Polarization	Horizontal
-----------	--------------------------	--------------	------------

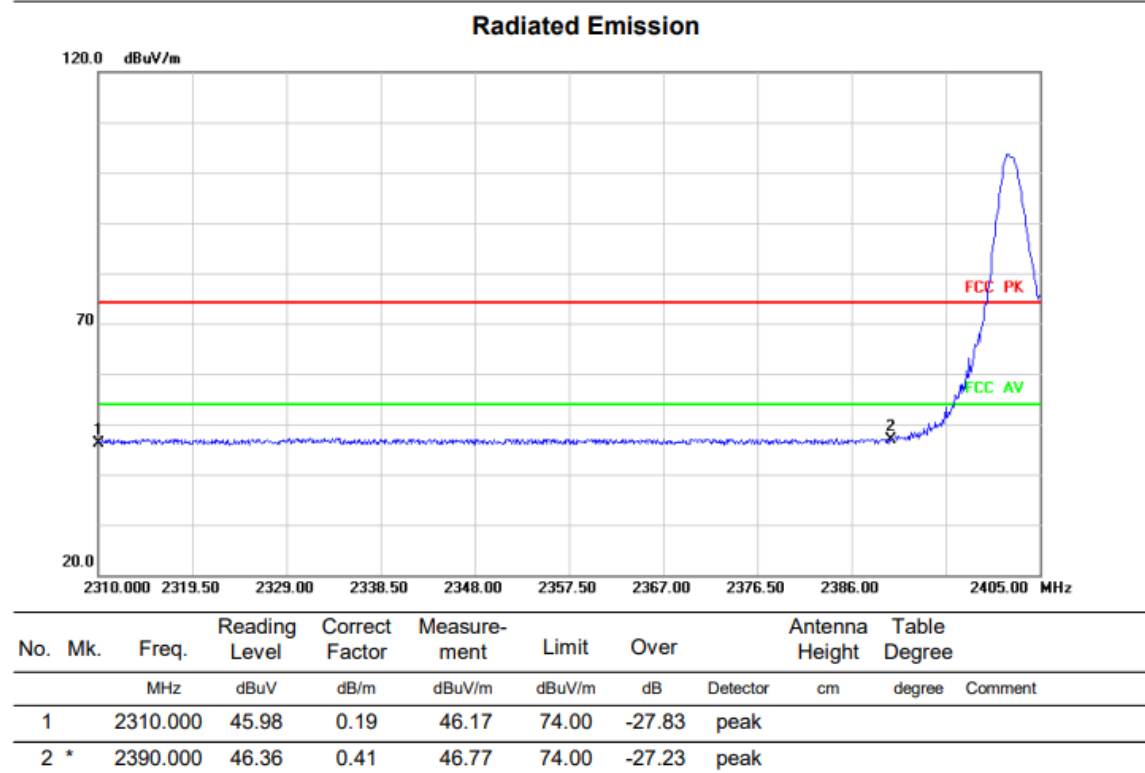
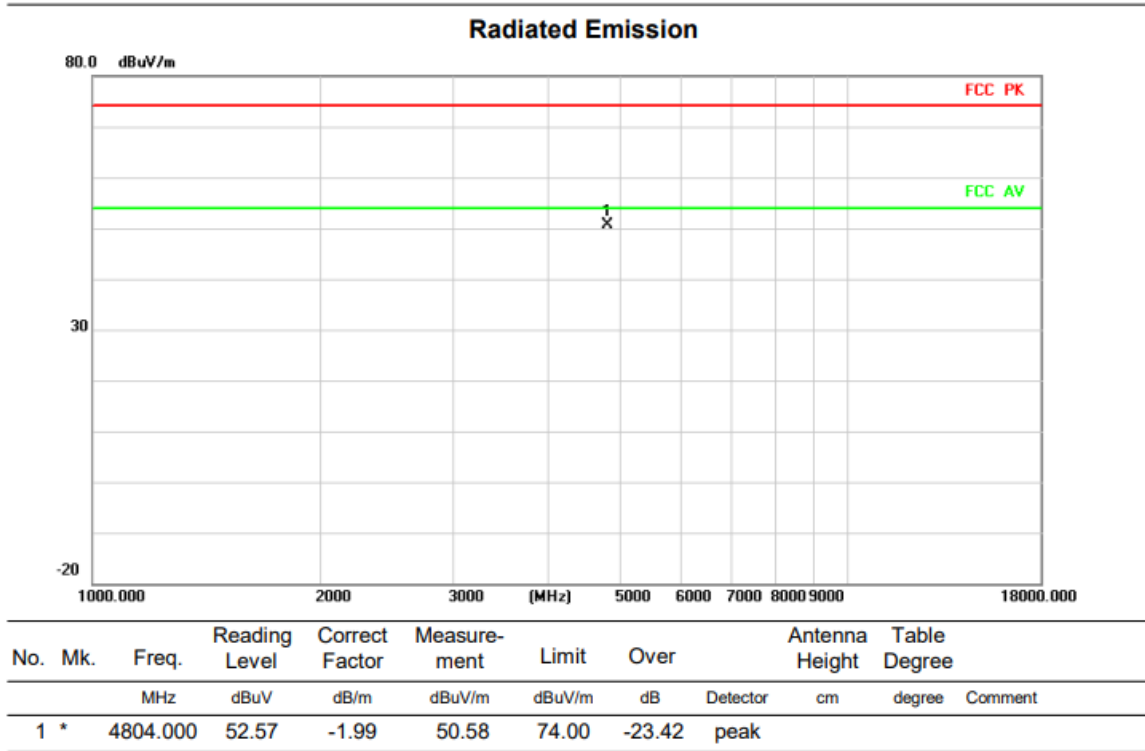

Test Mode	TX Mode_1Mbps Channel 39	Polarization	Vertical
-----------	--------------------------	--------------	----------

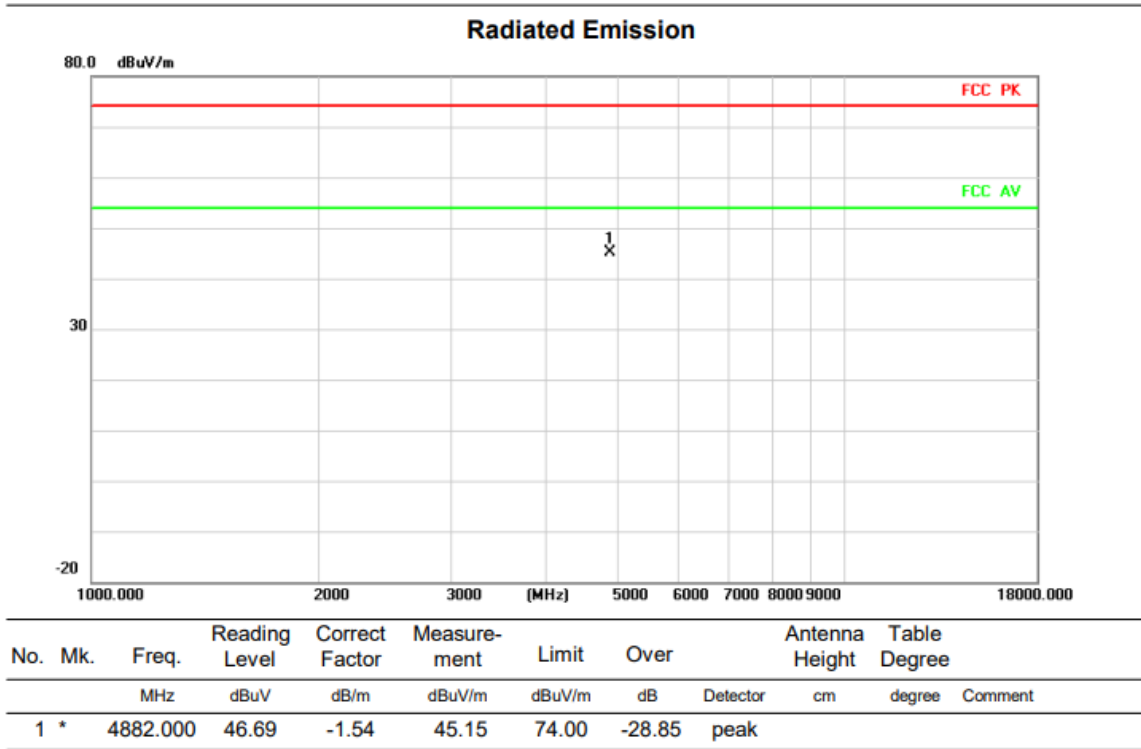

Test Mode	TX Mode_1Mbps Channel 39	Polarization	Horizontal
-----------	--------------------------	--------------	------------

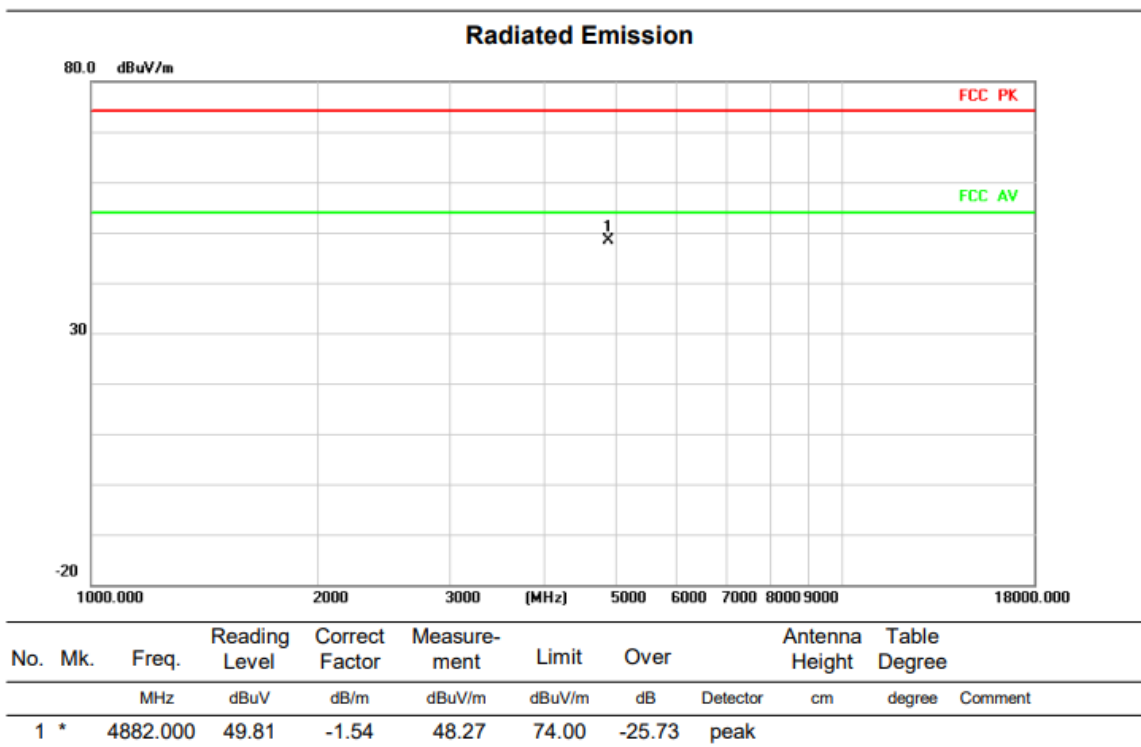

Test Mode	TX Mode_1Mbps Channel78	Polarization	Vertical
-----------	-------------------------	--------------	----------

### Radiated Emission

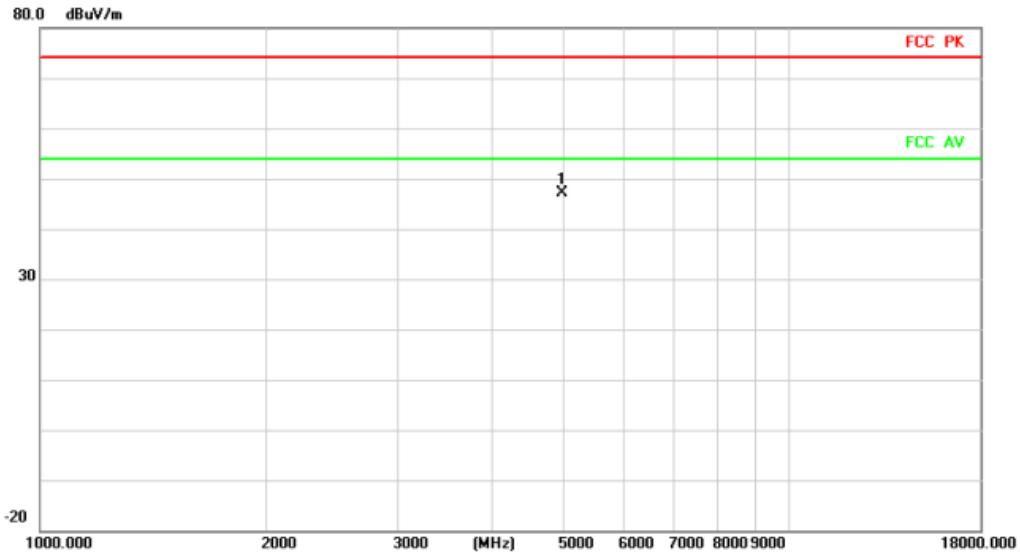

No.	Mk.	Freq.	Reading Level	Correct Factor	Measurement	Limit	Over	Antenna Height	Table Degree	
		MHz	dBuV	dB/m	dBuV/m	dBuV/m	dB	cm	degree	Comment
1	*	4960.000	48.29	-1.08	47.21	74.00	-26.79	peak		

### Radiated Emission

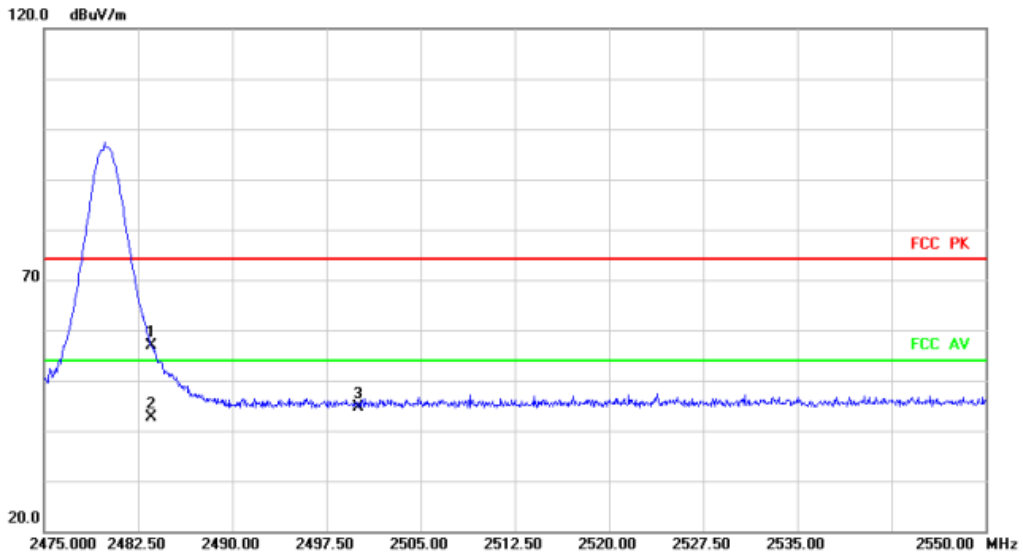

No.	Mk.	Freq.	Reading Level	Correct Factor	Measurement	Limit	Over	Antenna Height	Table Degree	
		MHz	dBuV	dB/m	dBuV/m	dBuV/m	dB	cm	degree	Comment
1		2483.500	55.88	1.09	56.97	74.00	-17.03	peak		
2	*	2483.500	41.48	1.09	42.57	54.00	-11.43	AVG		
3		2500.000	43.44	1.22	44.66	74.00	-29.34	peak		

Test Mode	TX Mode_1Mbps Channel 78	Polarization	Horizontal
-----------	--------------------------	--------------	------------

### Radiated Emission

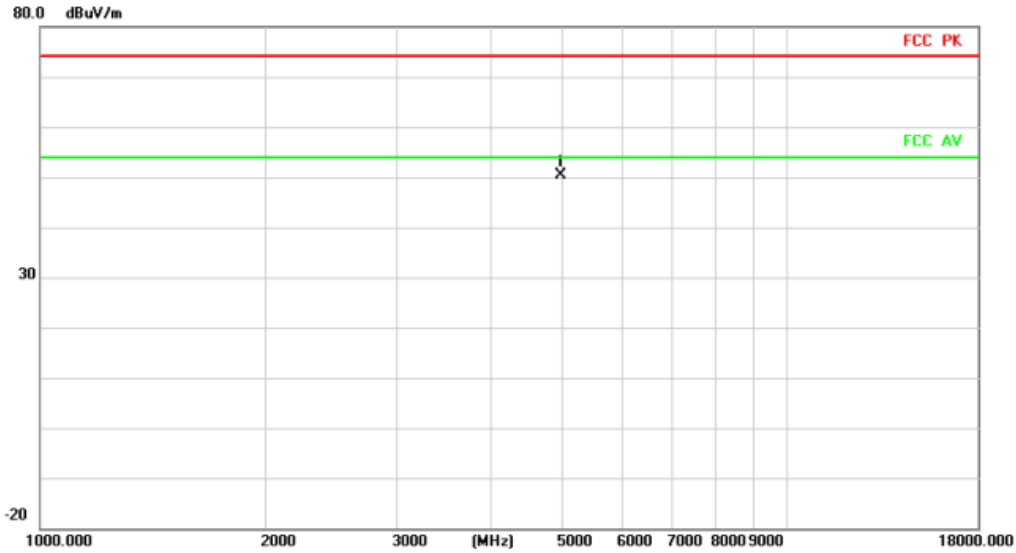

No.	Mk.	Freq.	Reading Level	Correct Factor	Measurement	Limit	Over	Antenna Height	Table Degree
		MHz	dBuV	dB/m	dBuV/m	dBuV/m	dB	cm	degree
1	*	4960.000	51.38	-1.08	50.30	74.00	-23.70	peak	

### Radiated Emission

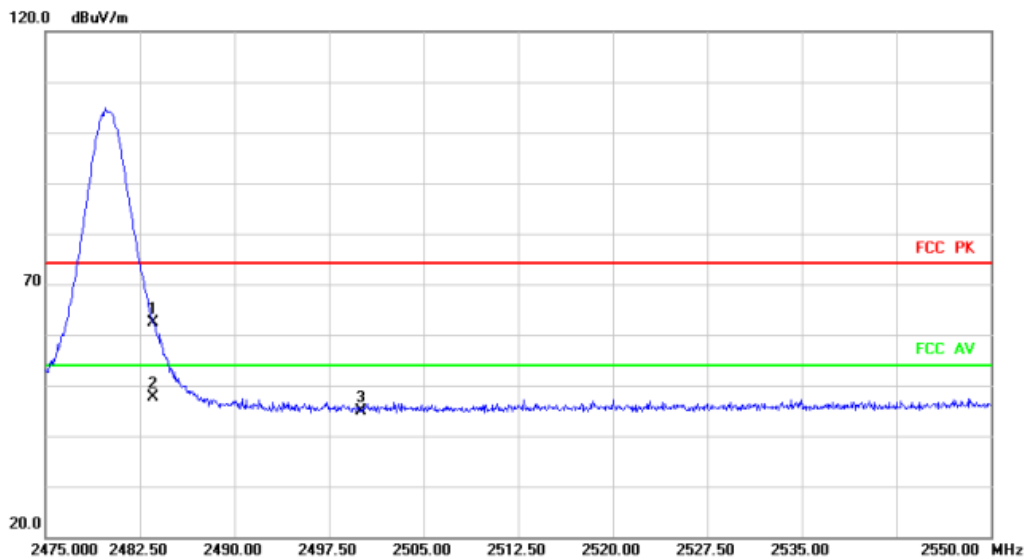

No.	Mk.	Freq.	Reading Level	Correct Factor	Measurement	Limit	Over	Antenna Height	Table Degree
		MHz	dBuV	dB/m	dBuV/m	dBuV/m	dB	cm	degree
1		2483.500	61.40	1.09	62.49	74.00	-11.51	peak	
2	*	2483.500	46.45	1.09	47.54	54.00	-6.46	AVG	
3		2500.000	43.78	1.22	45.00	74.00	-29.00	peak	

Test Mode	TX Mode_3Mbps Channel 00	Polarization	Vertical
-----------	--------------------------	--------------	----------

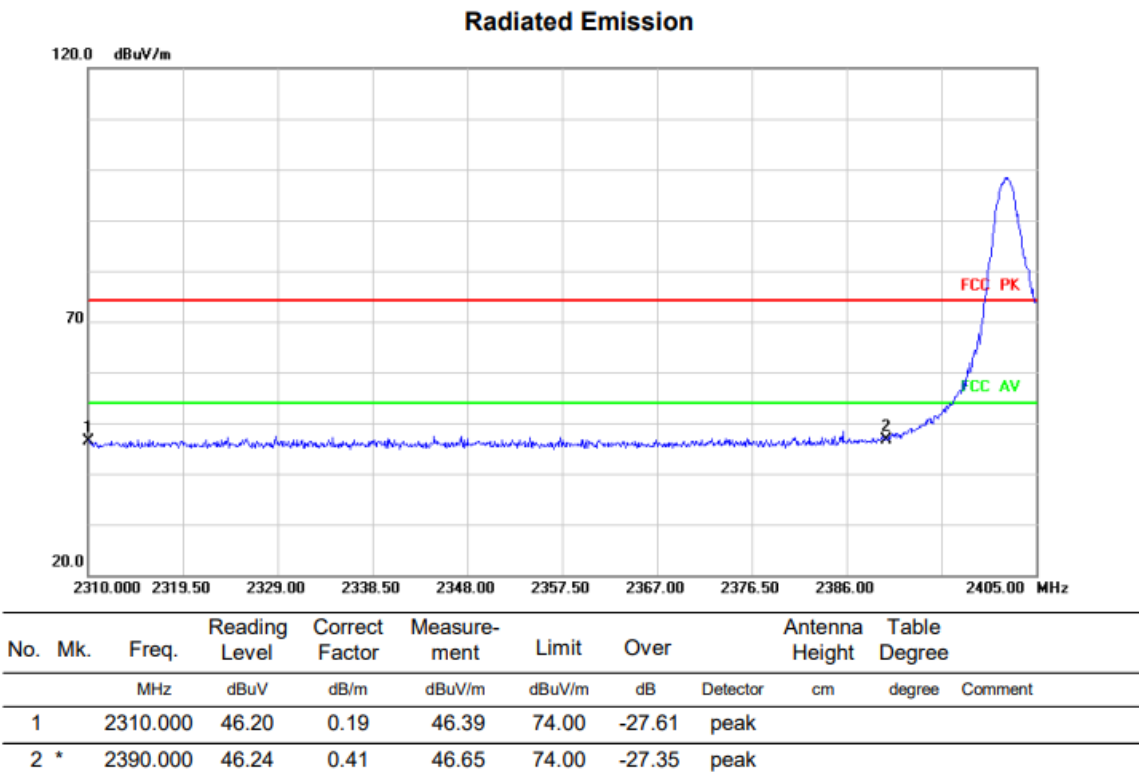
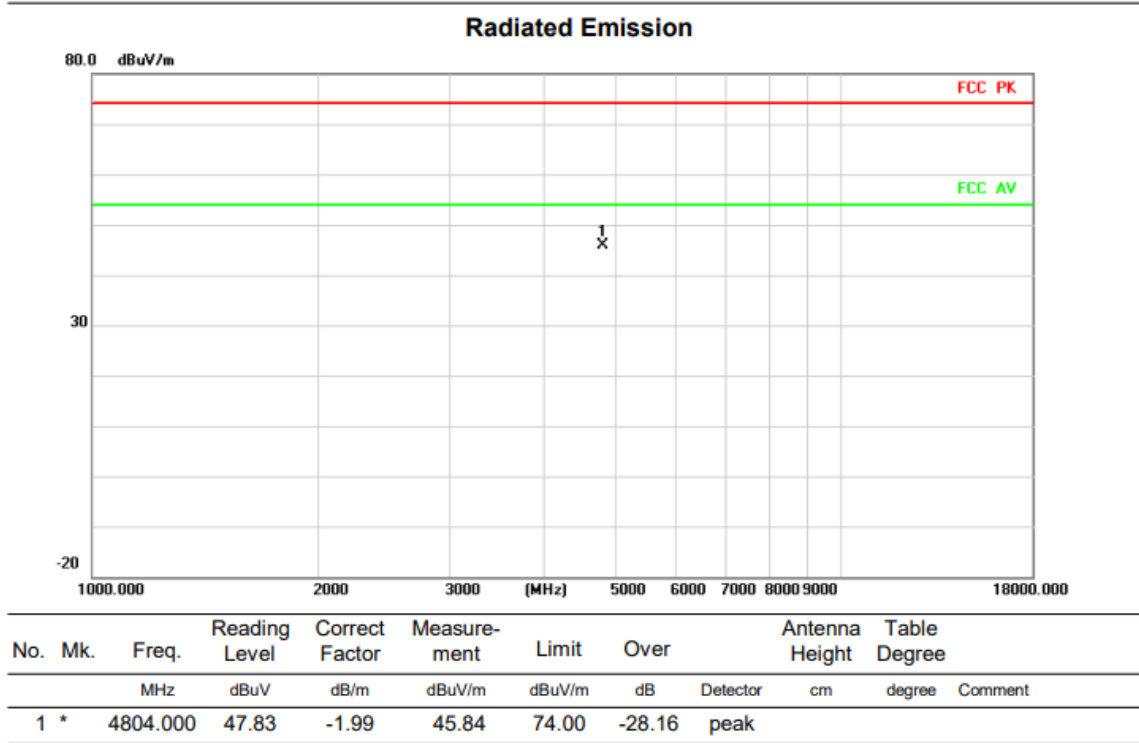

Test Mode	TX Mode_3Mbps Channel 00	Polarization	Horizontal
-----------	--------------------------	--------------	------------

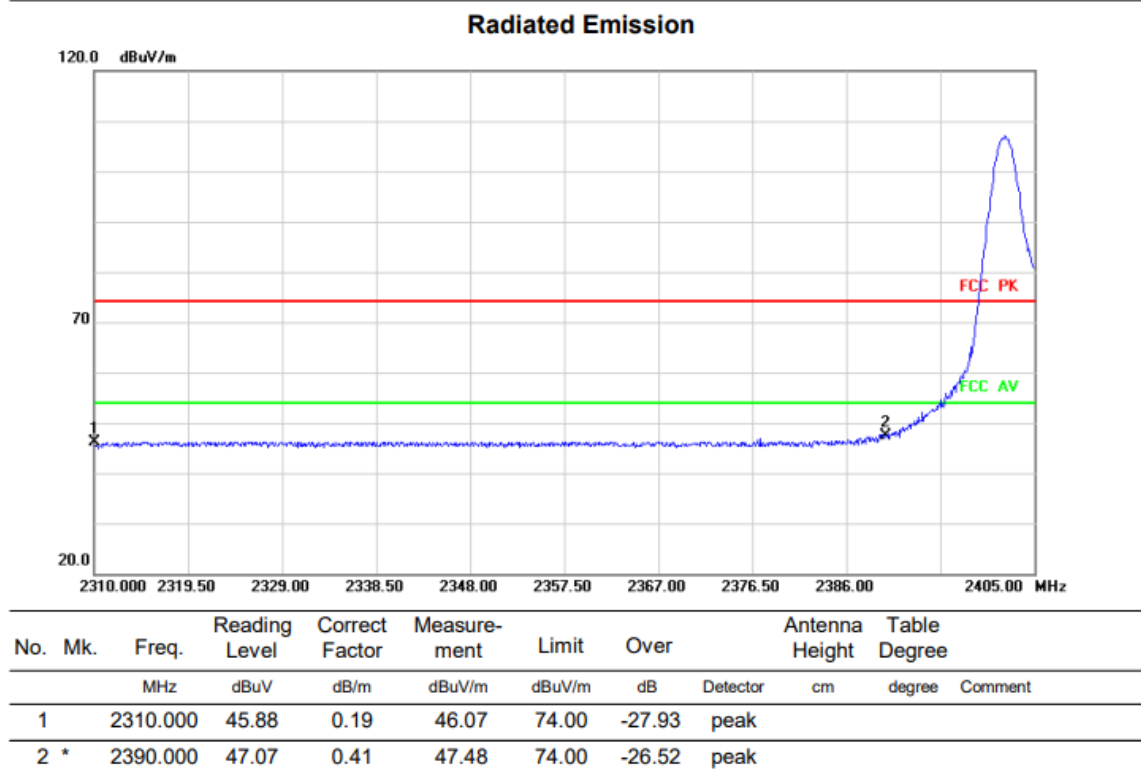
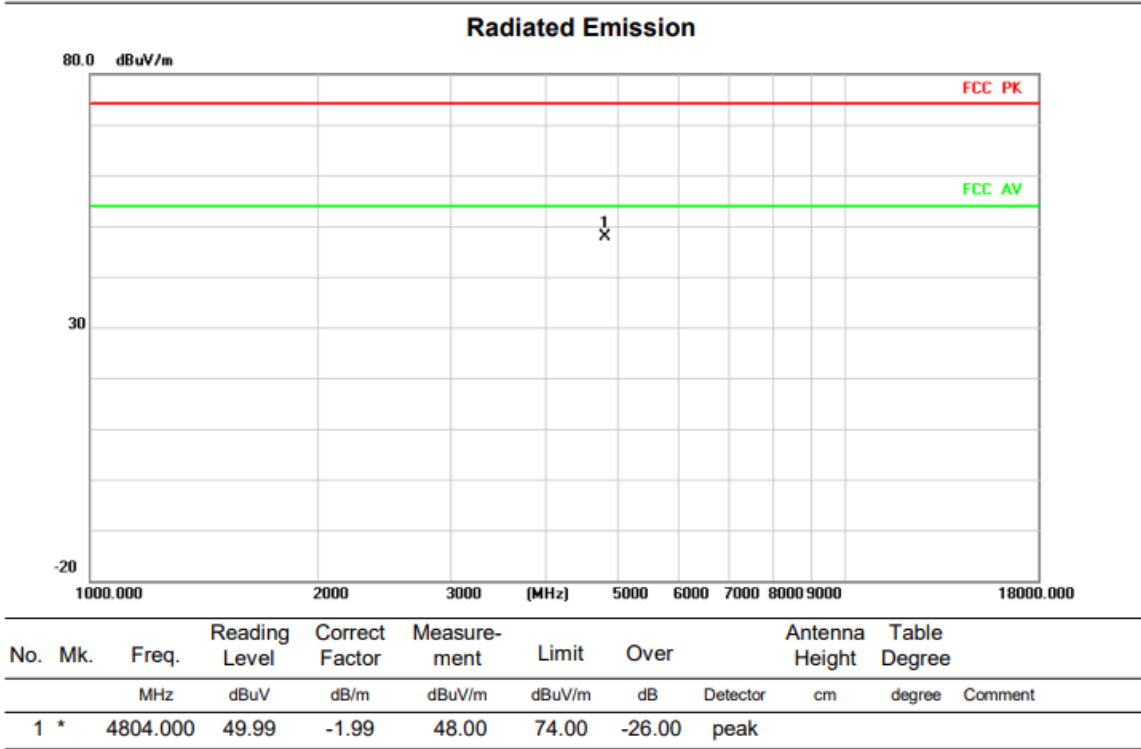

Test Mode	TX Mode_3Mbps Channel 39	Polarization	Vertical
-----------	--------------------------	--------------	----------

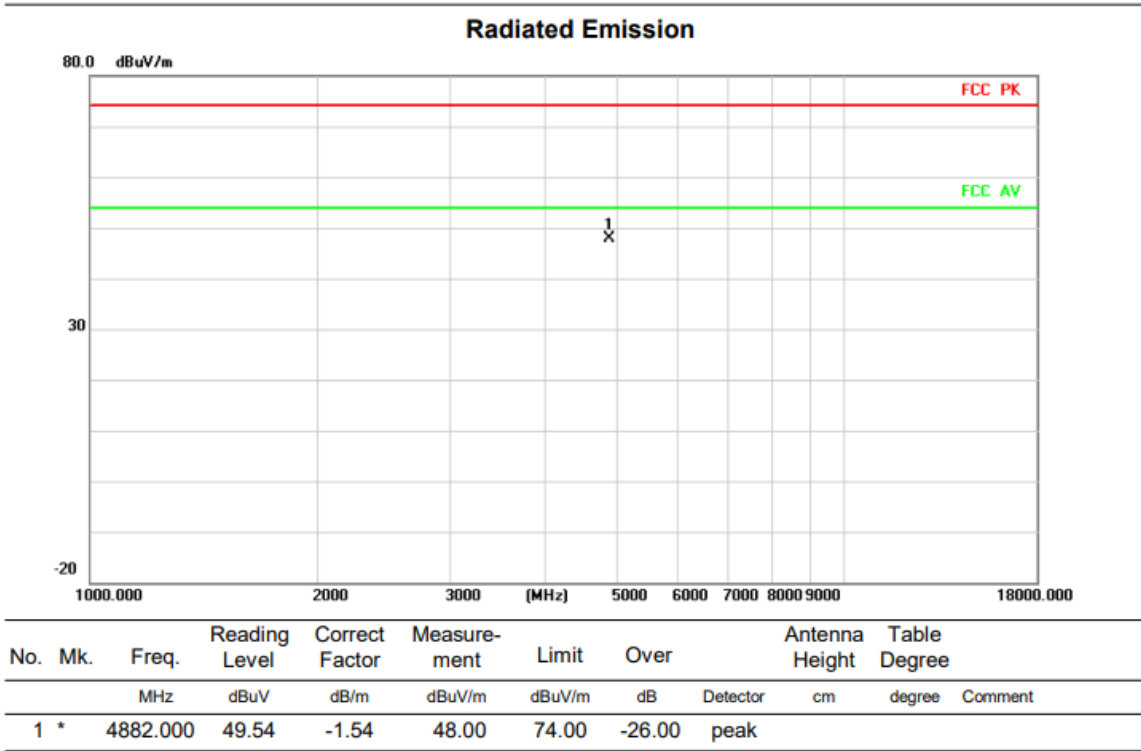

Test Mode	TX Mode_3Mbps Channel 39	Polarization	Horizontal
-----------	--------------------------	--------------	------------

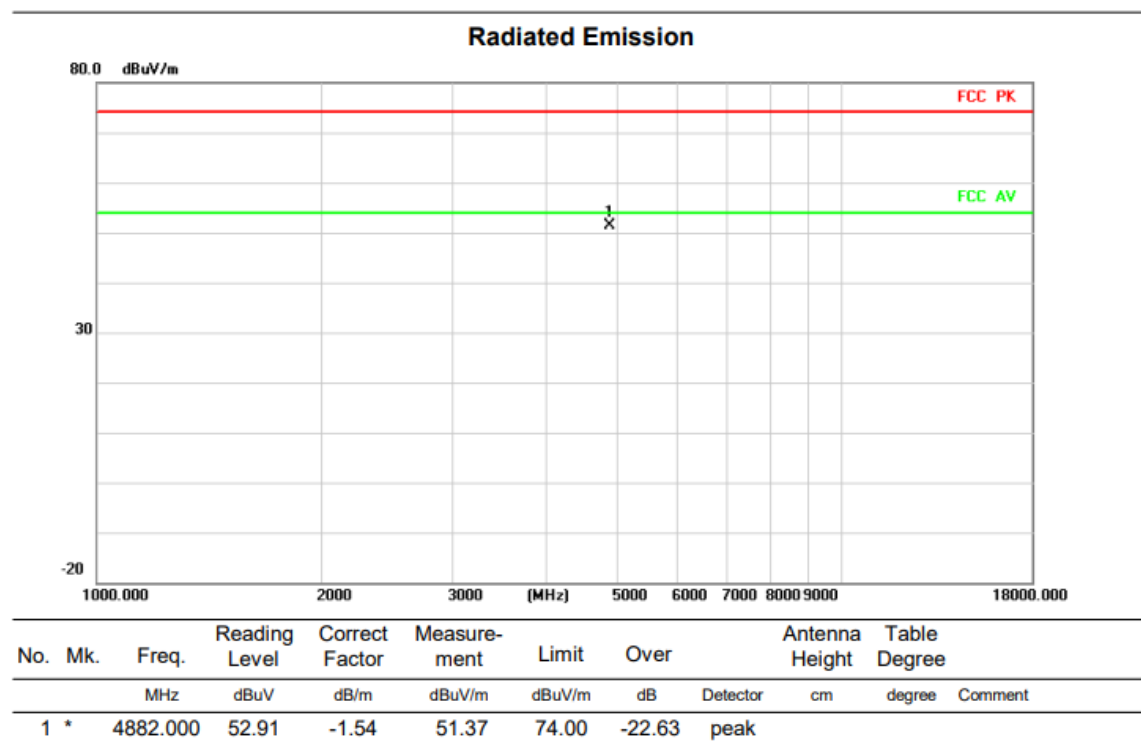



Test Mode	TX Mode_3Mbps Channel 78	Polarization	Vertical
-----------	--------------------------	--------------	----------

### Radiated Emission

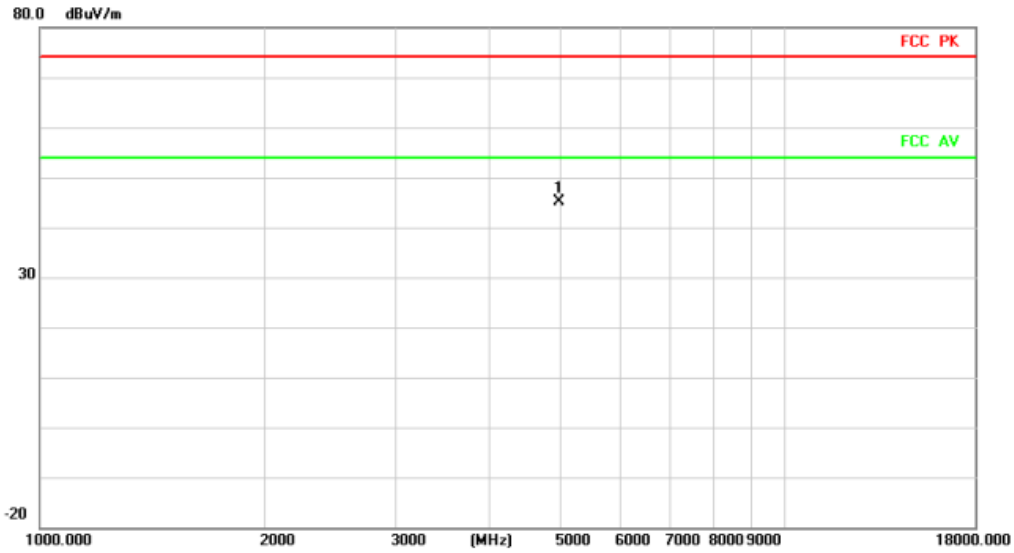

No.	Mk.	Freq.	Reading Level	Correct Factor	Measurement	Limit	Over	Antenna Height	Table Degree
		MHz	dBuV	dB/m	dBuV/m	dBuV/m	dB	cm	degree
1	*	4960.000	46.22	-1.08	45.14	74.00	-28.86	peak	

### Radiated Emission

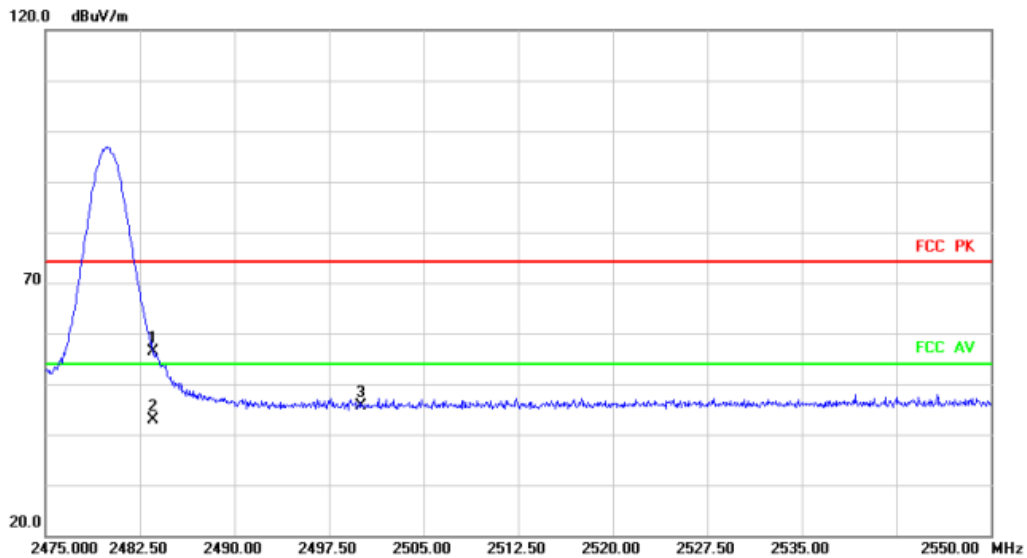

No.	Mk.	Freq.	Reading Level	Correct Factor	Measurement	Limit	Over	Antenna Height	Table Degree
		MHz	dBuV	dB/m	dBuV/m	dBuV/m	dB	cm	degree
1		2483.500	55.28	1.09	56.37	74.00	-17.63	peak	
2	*	2483.500	41.69	1.09	42.78	54.00	-11.22	AVG	
3		2500.000	44.51	1.22	45.73	74.00	-28.27	peak	

Test Mode	TX Mode_3Mbps Channel 78	Polarization	Horizontal
-----------	--------------------------	--------------	------------

### Radiated Emission

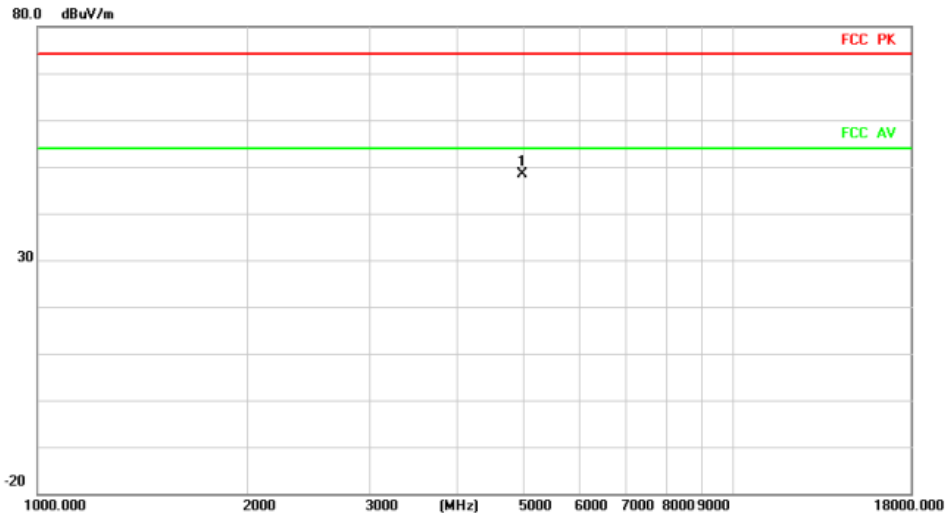

No.	Mk.	Freq.	Reading Level	Correct Factor	Measurement	Limit	Over	Antenna Height	Table Degree
		MHz	dBuV	dB/m	dBuV/m	dBuV/m	dB	cm	degree
1	*	4960.000	49.56	-1.08	48.48	74.00	-25.52	peak	

### Radiated Emission

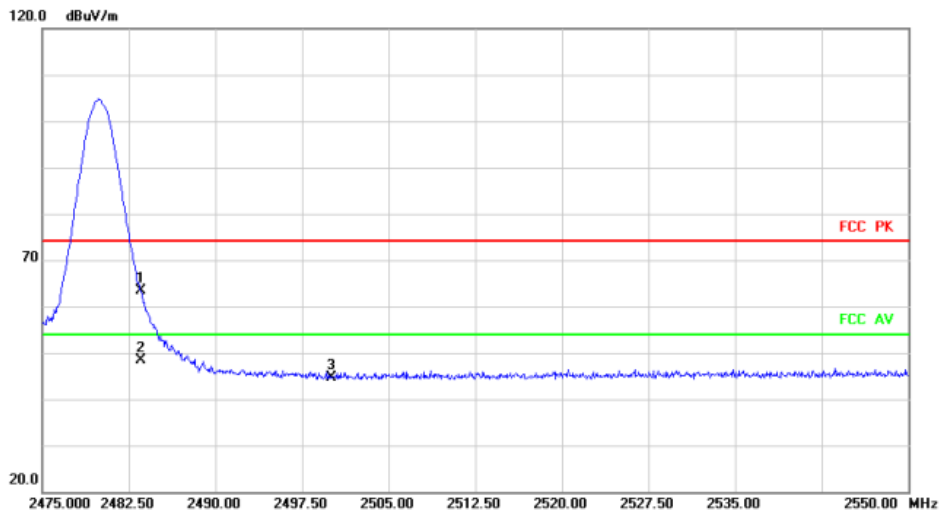

No.	Mk.	Freq.	Reading Level	Correct Factor	Measurement	Limit	Over	Antenna Height	Table Degree
		MHz	dBuV	dB/m	dBuV/m	dBuV/m	dB	cm	degree
1		2483.500	62.36	1.09	63.45	74.00	-10.55	peak	
2	*	2483.500	47.28	1.09	48.37	54.00	-5.63	AVG	
3		2500.000	43.31	1.22	44.53	74.00	-29.47	peak	

REMARKS:

- (1) Measurement Value = Reading Level + Correct Factor.
- (2) Margin Level = Measurement Value - Limit Value.

## APPENDIX E - NUMBER OF HOPPING FREQUENCY

Test Mode	Antenna	Freq(MHz)	Result[Num]	Limit[Num]	Verdict
DH5	Ant1	Hop	79	≥15	PASS
2DH5	Ant1	Hop	79	≥15	PASS
3DH5	Ant1	Hop	79	≥15	PASS

### Test Graphs

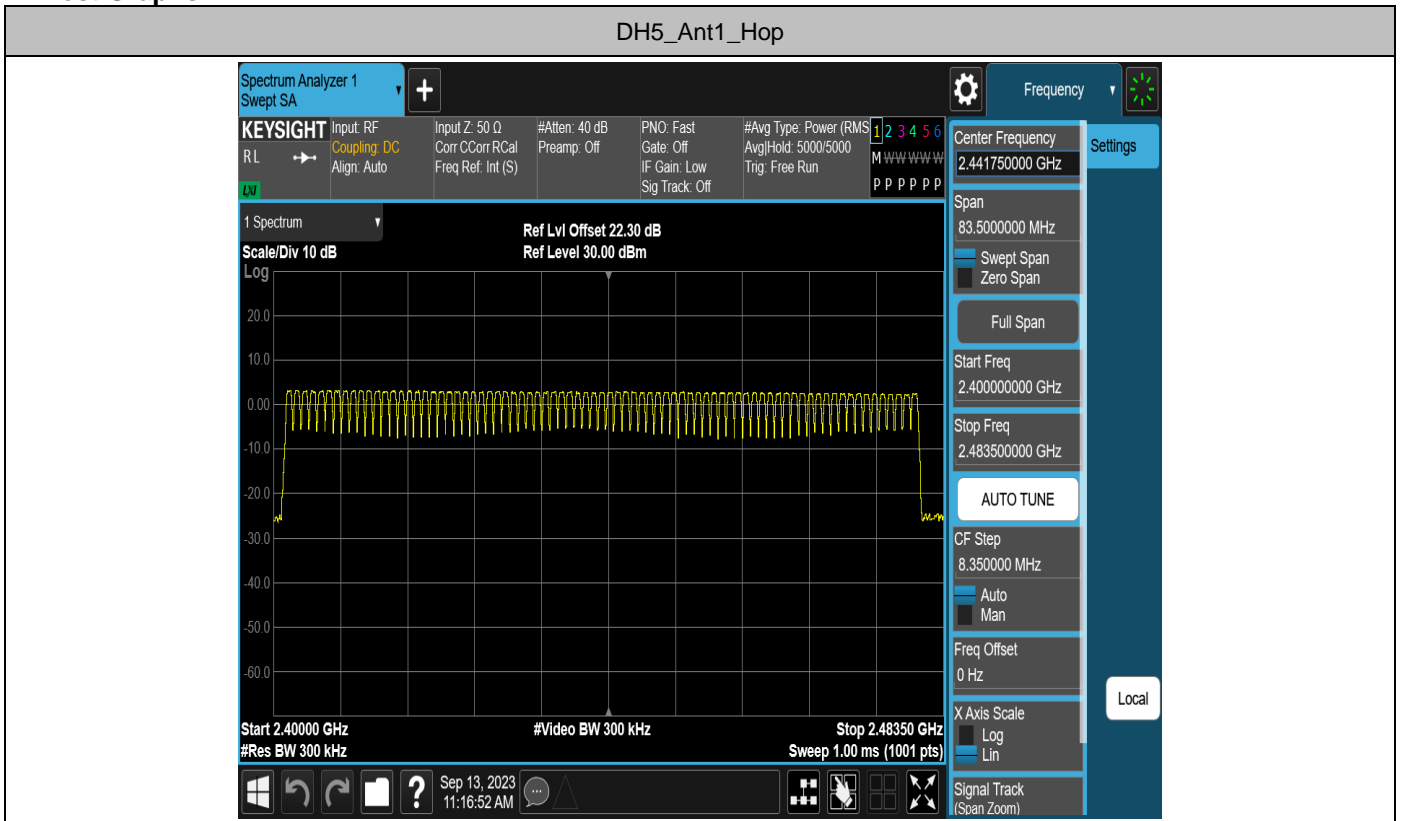

2DH5\_Ant1\_Hop

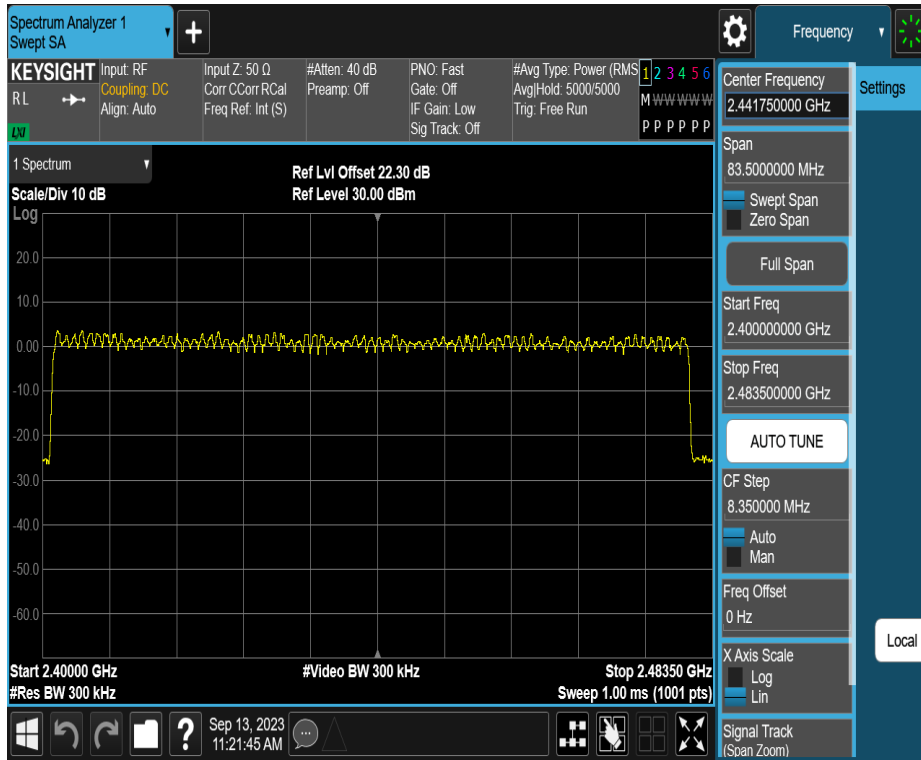

3DH5\_Ant1\_Hop

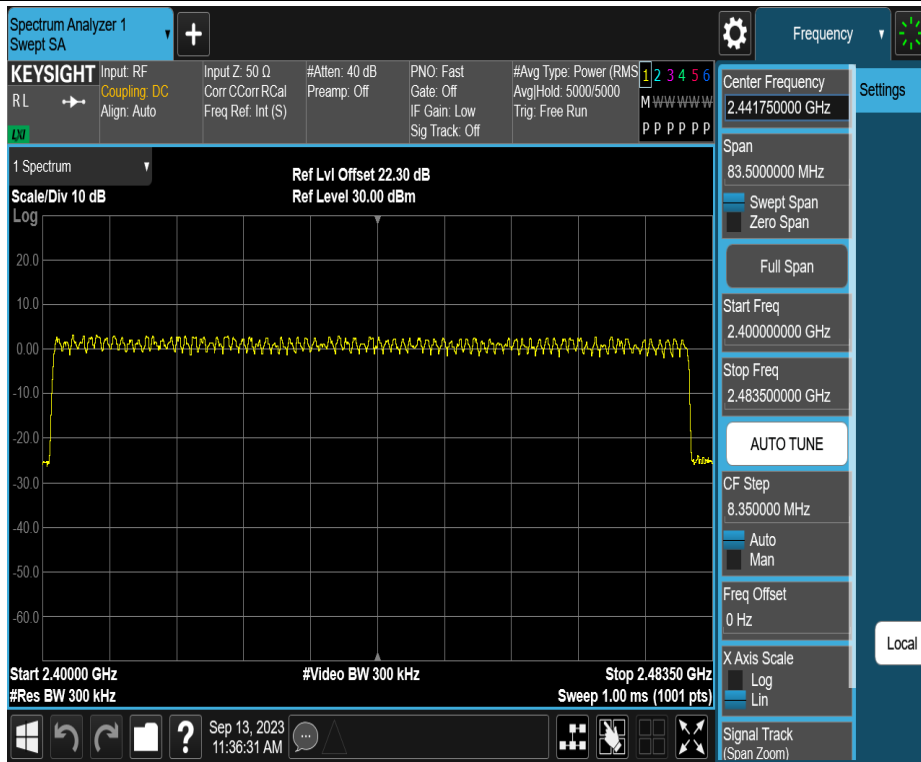

## APPENDIX F - AVERAGE TIME OF OCCUPANCY

Test Mode	Antenna	Freq(MHz)	BurstWidth [ms]	TotalHops [Num]	Result[s]	Limit[s]	Verdict
DH1	Ant1	Hop	0.372	315	0.117	≤0.4	PASS
DH3	Ant1	Hop	1.628	158	0.257	≤0.4	PASS
DH5	Ant1	Hop	2.868	107	0.307	≤0.4	PASS
2DH1	Ant1	Hop	0.383	315	0.121	≤0.4	PASS
2DH3	Ant1	Hop	1.631	160	0.261	≤0.4	PASS
2DH5	Ant1	Hop	2.879	107	0.308	≤0.4	PASS
3DH1	Ant1	Hop	0.383	316	0.121	≤0.4	PASS
3DH3	Ant1	Hop	1.629	160	0.261	≤0.4	PASS
3DH5	Ant1	Hop	2.880	107	0.308	≤0.4	PASS

### Test Graphs

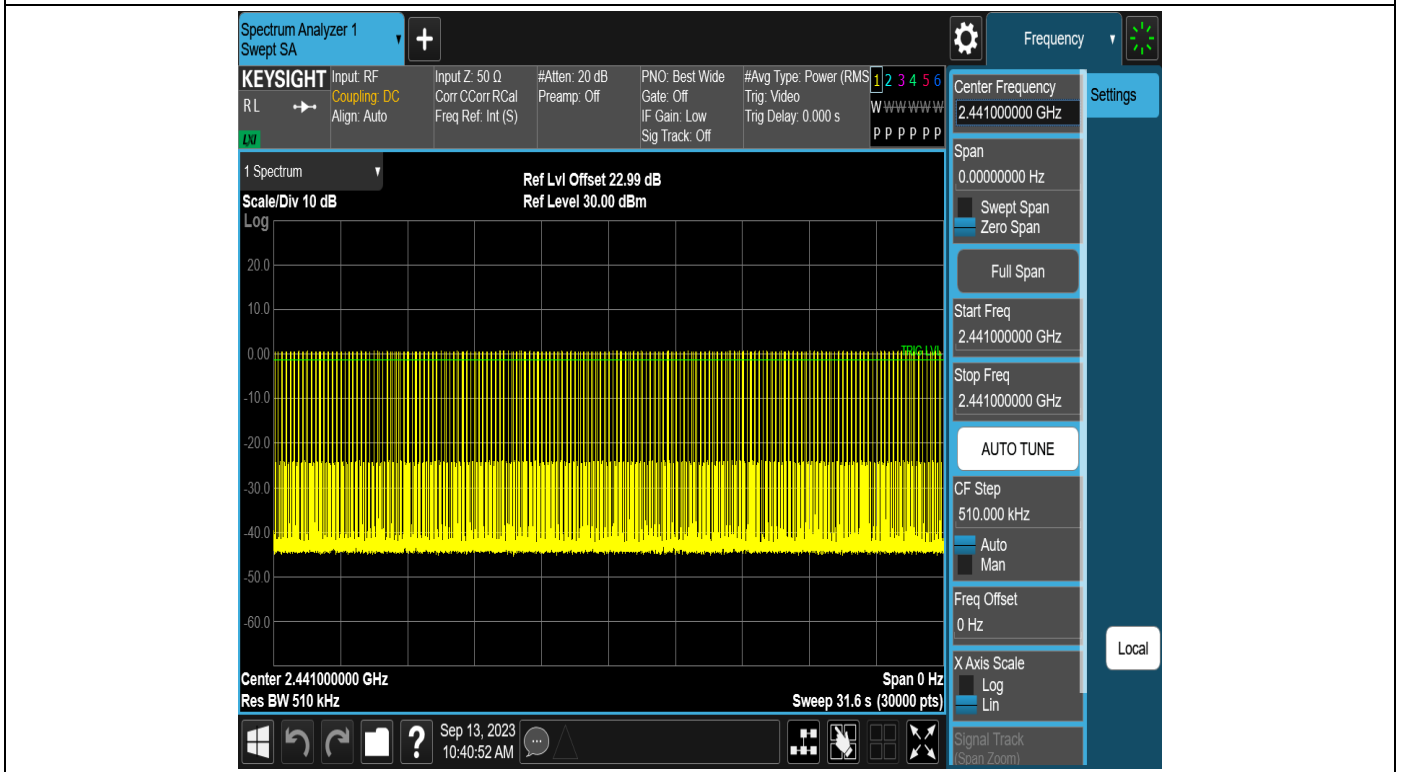
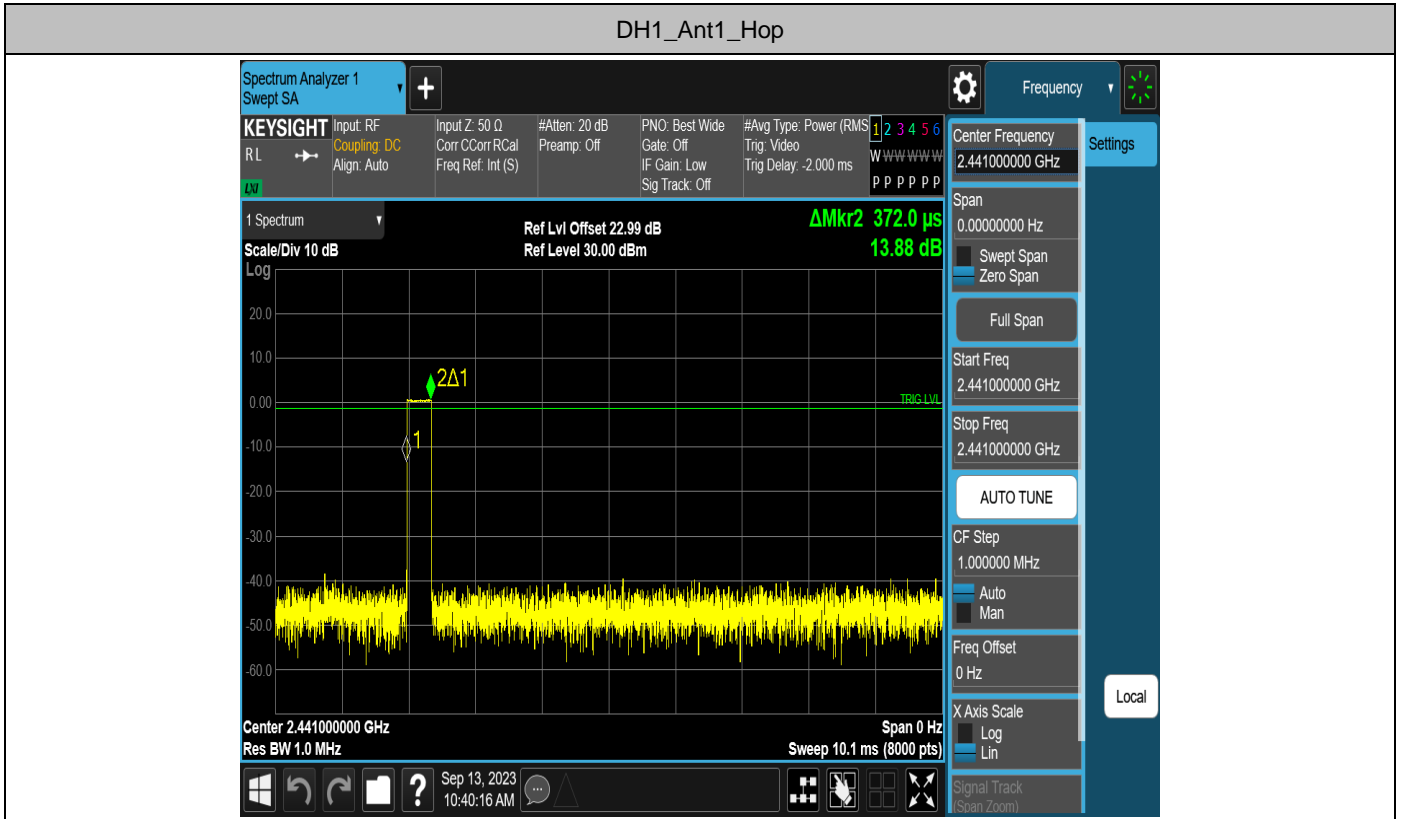



DH3\_Ant1\_Hop

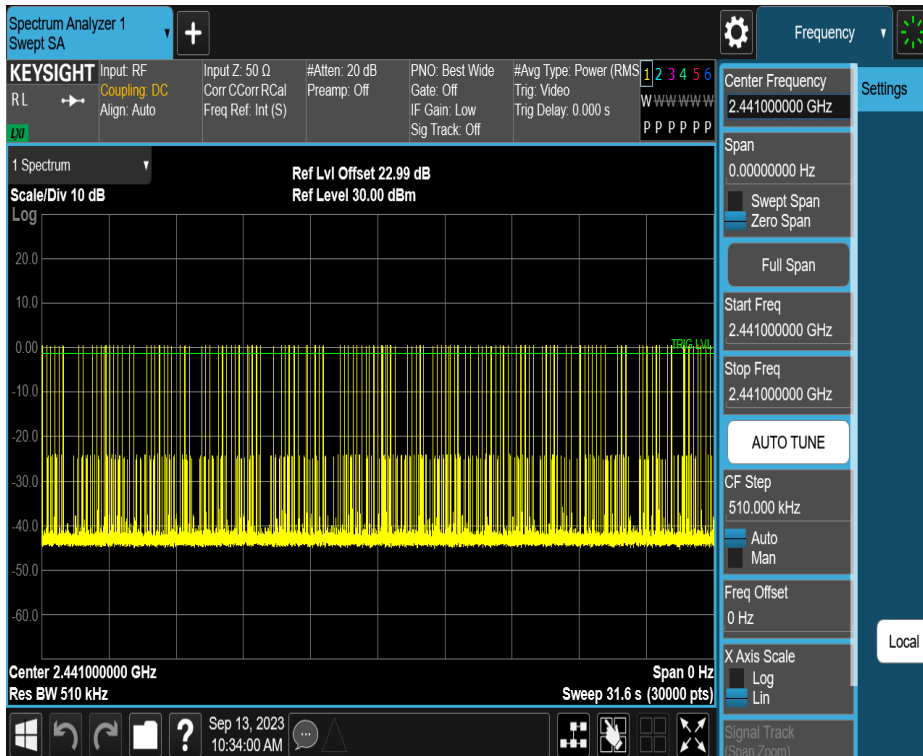
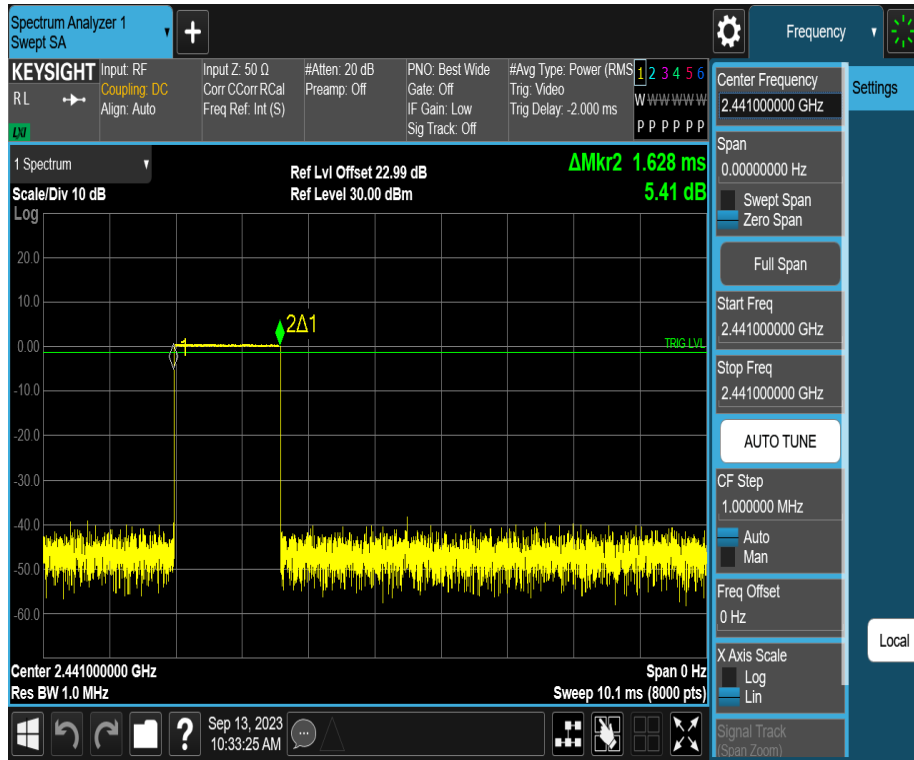

DH5\_Ant1\_Hop

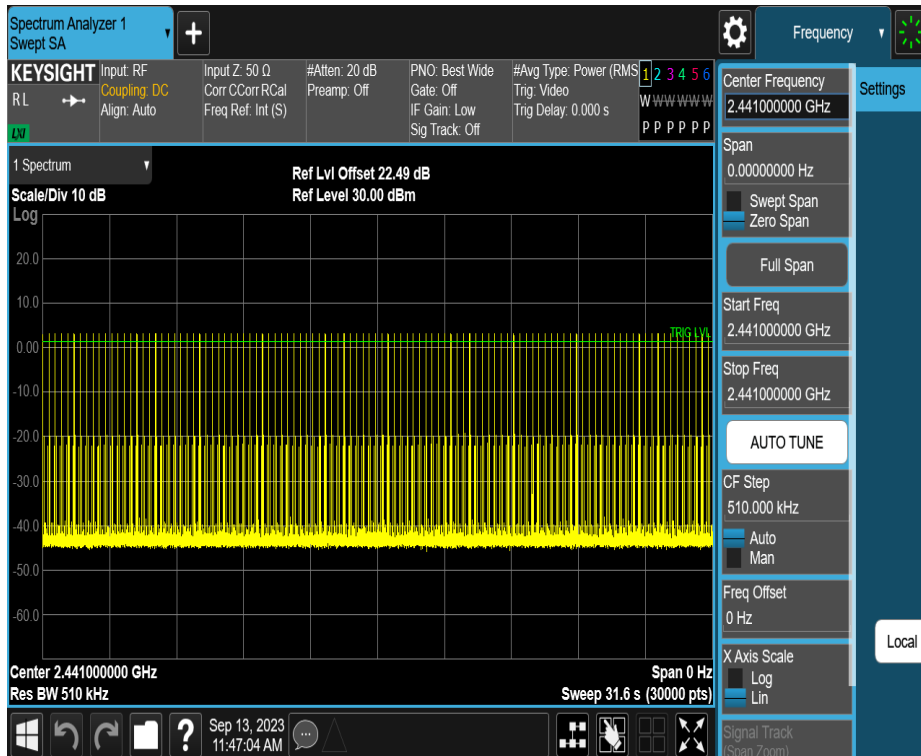
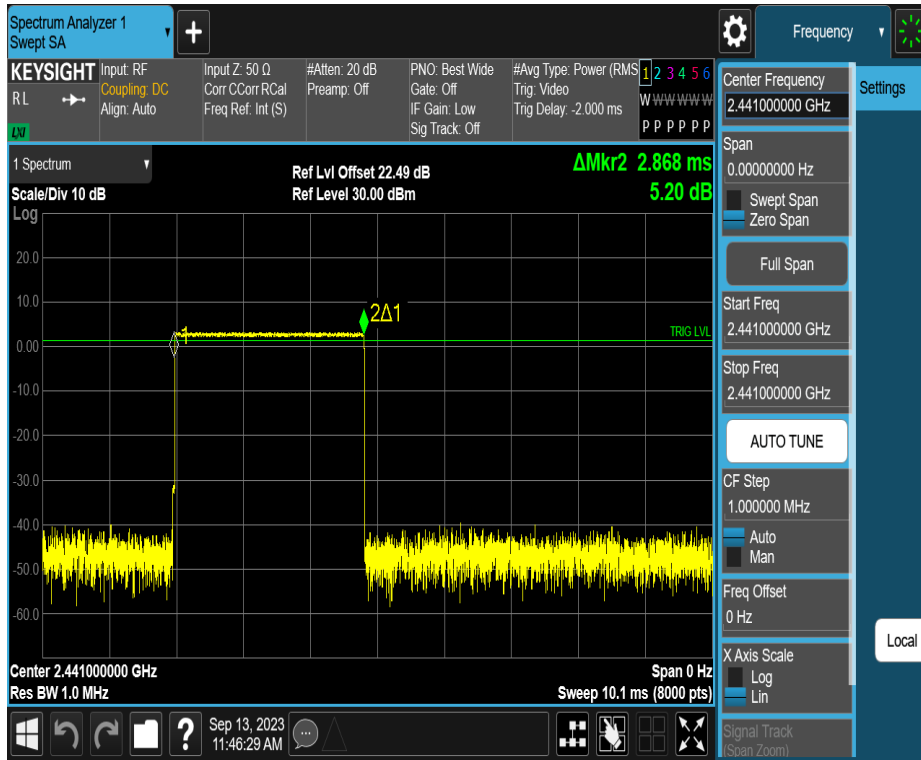

2DH1\_Ant1\_Hop

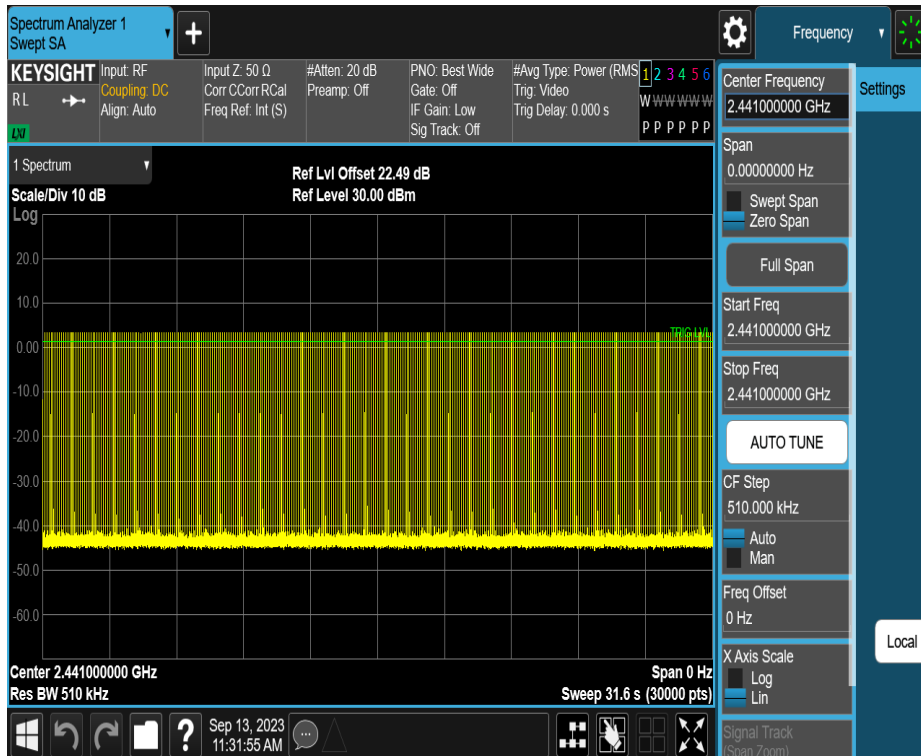
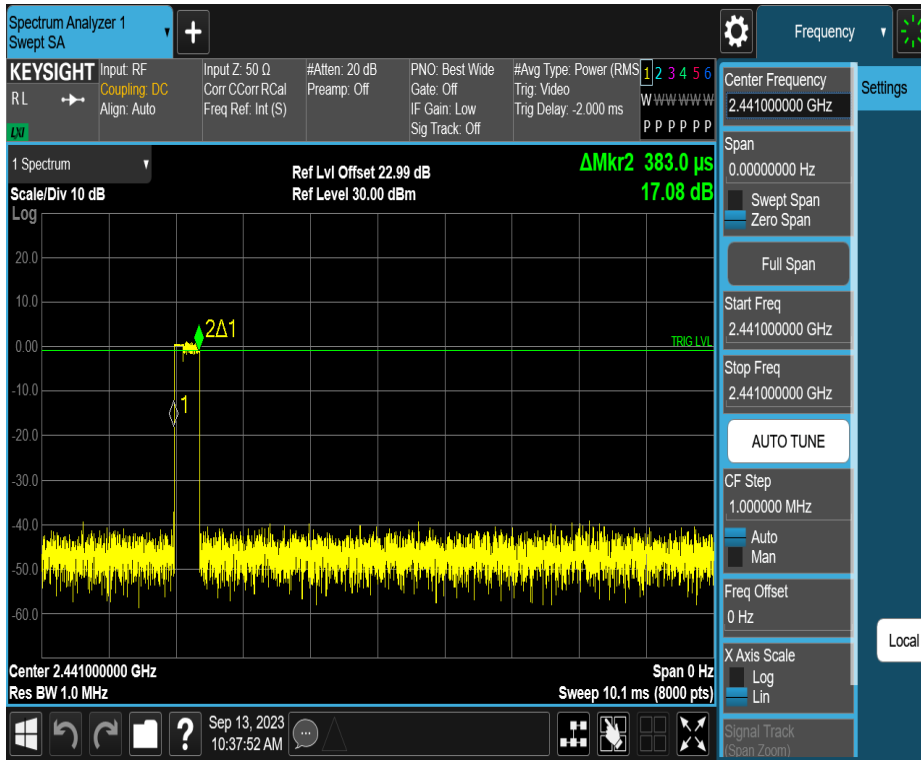

2DH3\_Ant1\_Hop

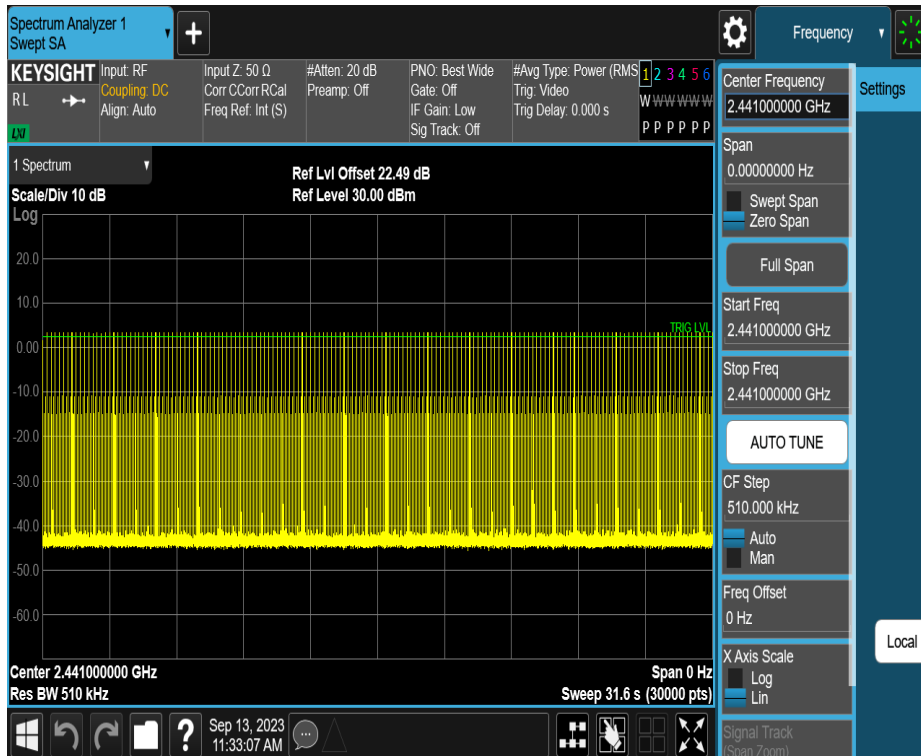
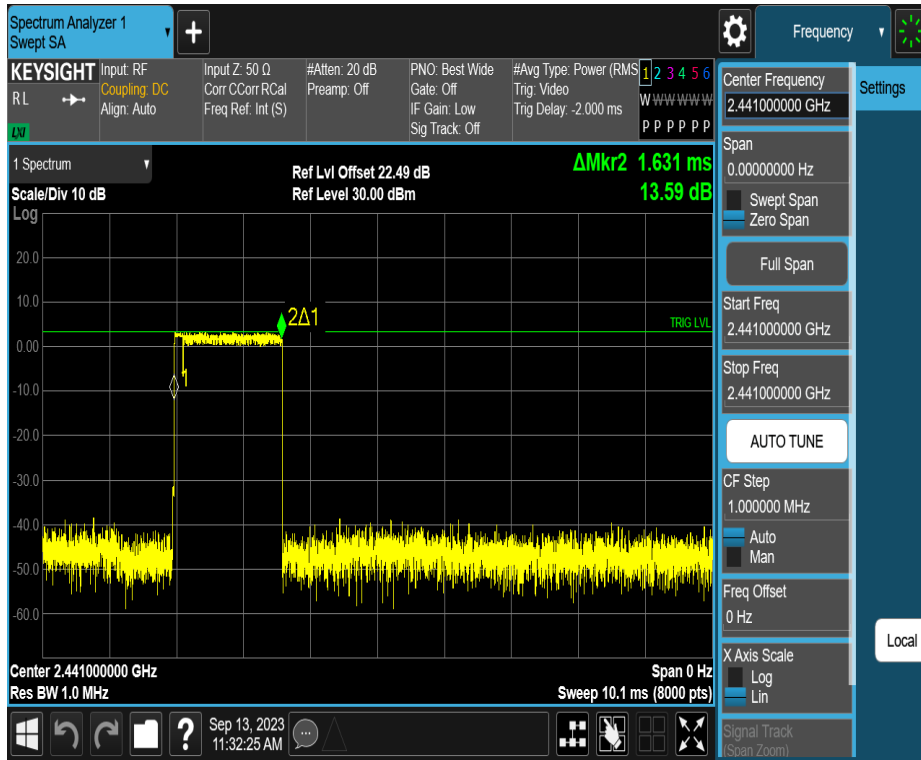

2DH5\_Ant1\_Hop

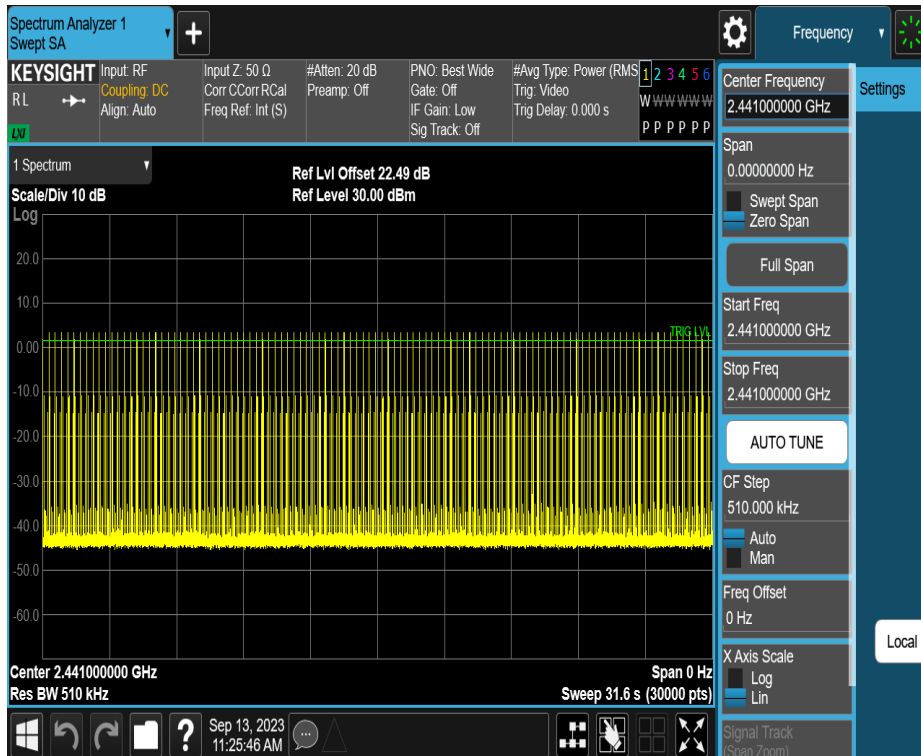
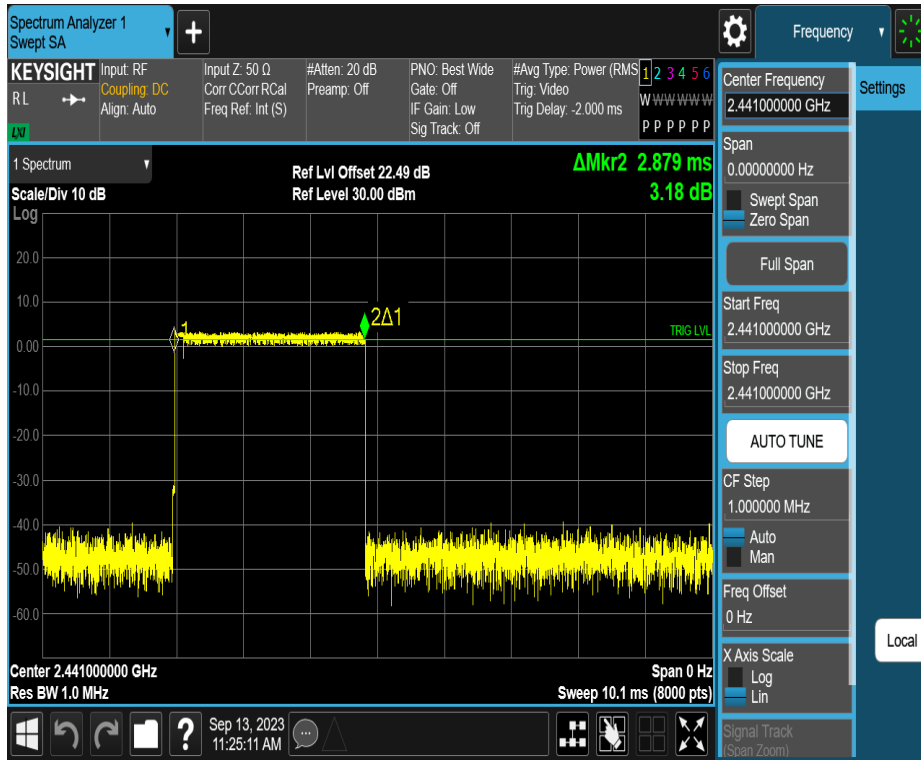

3DH1\_Ant1\_Hop

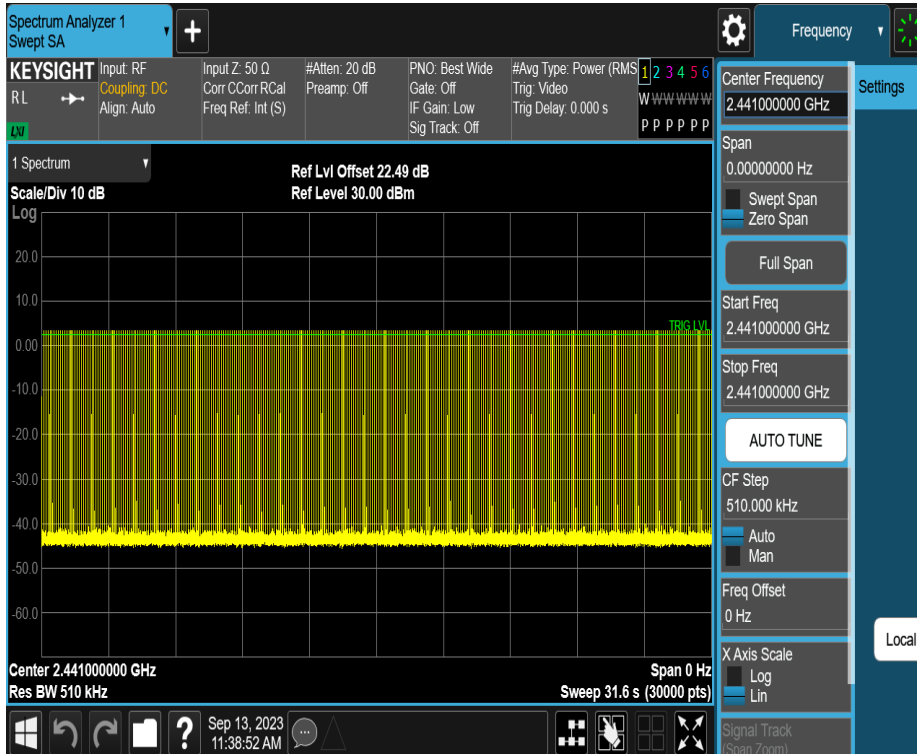
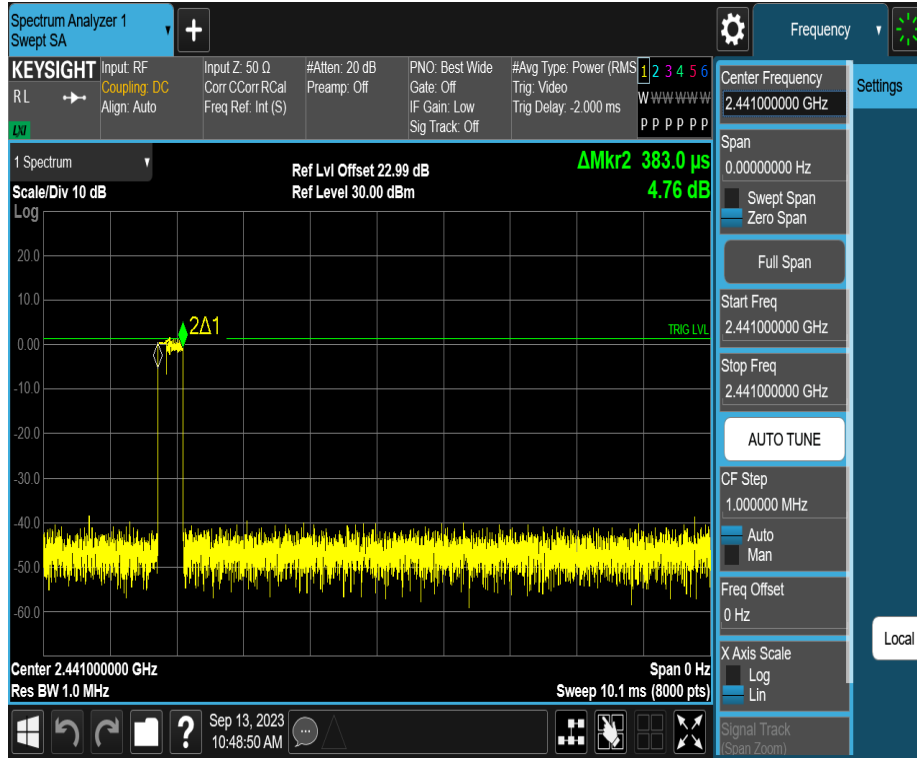

3DH3\_Ant1\_Hop

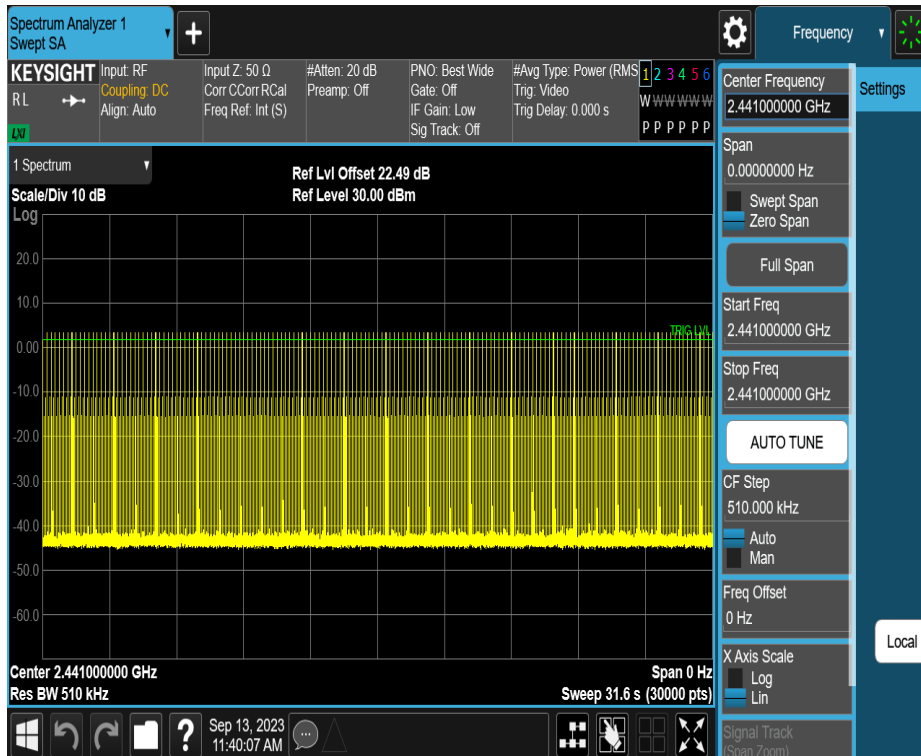
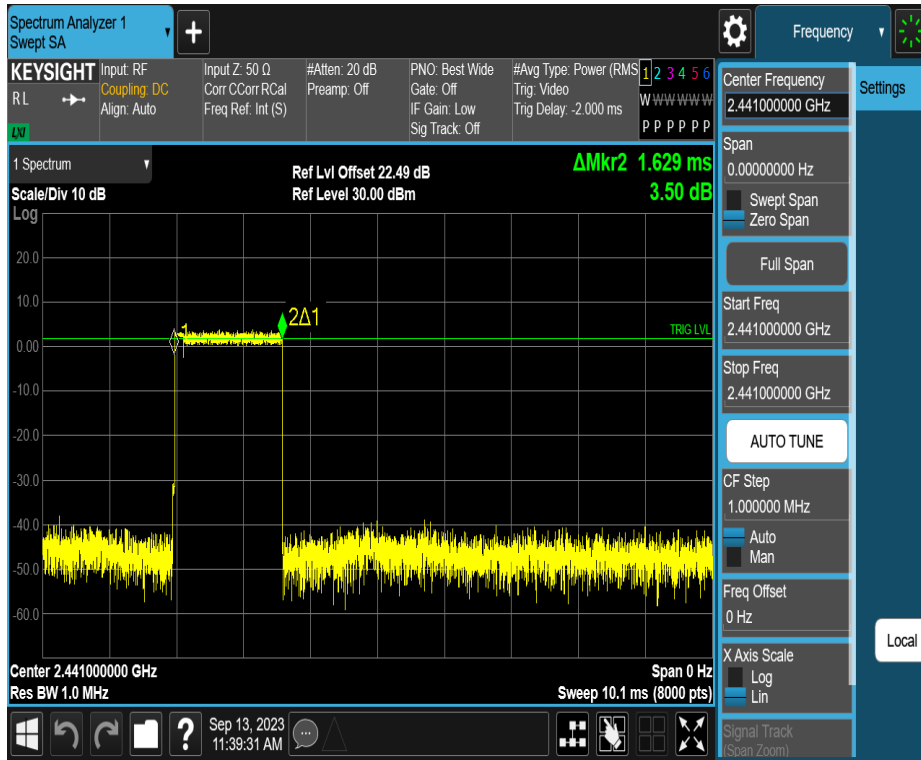

3DH5\_Ant1\_Hop

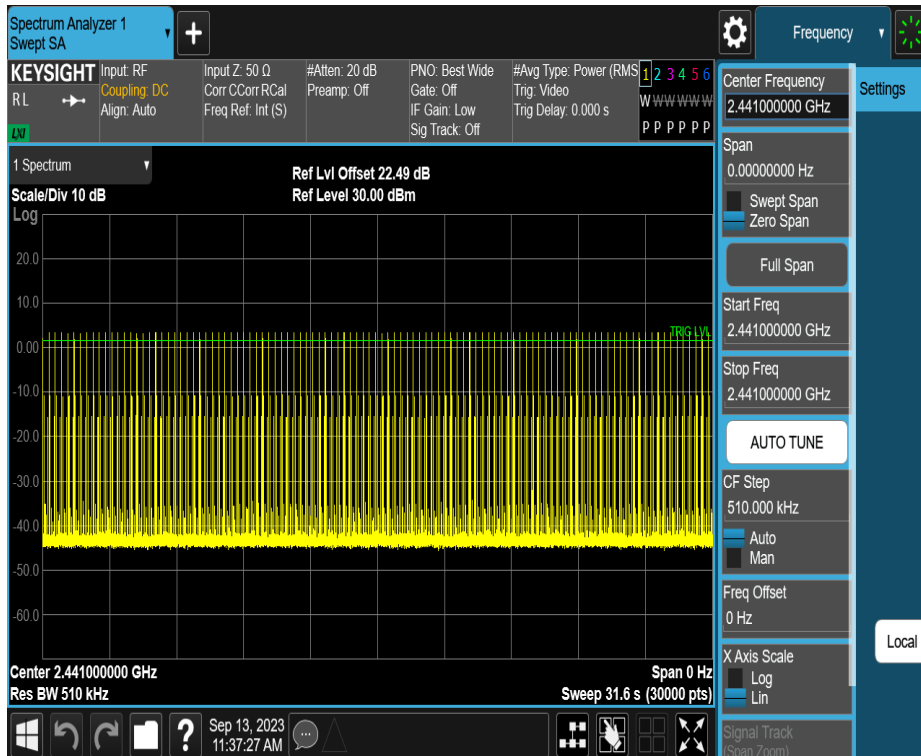
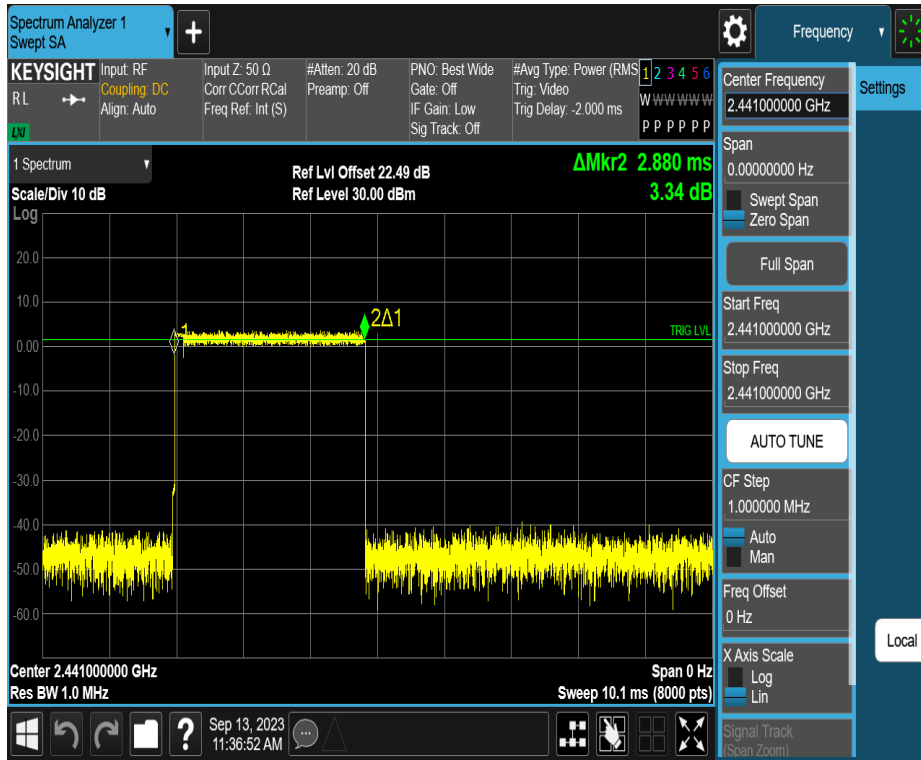



## APPENDIX G - HOPPING CHANNEL SEPARATION

Test Mode	Antenna	Freq(MHz)	Result[MHz]	Limit[MHz]	Verdict
DH5	Ant1	Hop	1.366	≥1.038	PASS
2DH5	Ant1	Hop	0.984	≥0.876	PASS
3DH5	Ant1	Hop	0.998	≥0.864	PASS

### Test Graphs

