

get started

INSTANT POT® **PRO MAX**
WIFI MULTI-COOKER

USER MANUAL

Instant®

Welcome

to your new Instant Pot® Pro Max WiFi!

This Instant Pot multi-cooker can help you cook healthy, delicious meals more easily and in less time. And with WiFi connectivity to the Instant Connect™ app, you'll be able to control and monitor your cooking, as well as use recipe settings from the app. We hope you fall in love with Instant Pot cooking and enjoy it in your kitchen for years to come!

FCC Compliance Statement

Warning: Changes or modifications to this unit not expressly approved by the party responsible for compliance could void the user's authority to operate the equipment.

NOTE: This equipment has been tested and found to comply with the limits for a Class B digital device, pursuant to Part 15 of the FCC Rules. These limits are designed to provide reasonable protection against harmful interference in a residential installation. This equipment generates, uses and can radiate radio frequency energy and, if not installed and used in accordance with the instructions, may cause harmful interference to radio communications.

However, there is no guarantee that interference will not occur in a particular installation. If this equipment does cause harmful interference to radio or television reception, which can be determined by turning the equipment off and on, the user is encouraged to try to correct the interference by one or more of the following measures:

- Reorient or relocate the receiving antenna.
- Increase the separation between the equipment and receiver.
- Connect the equipment into an outlet on a circuit different from that to which the receiver is connected.
- Consult the dealer or an experienced radio/TV technician for help

The device must not be co-located or operating in conjunction with any other antenna or transmitter.

Caution: Changes or modifications not expressly approved by the party responsible for compliance could void the user's authority to operate the equipment.

This device complies with Part 15 of the FCC Rules. Operation is subject to the following two conditions: (1) this device may not cause harmful interference, and (2) this device must accept any interference received, including interference that may cause undesired operation.

FCC RF Radiation Exposure Statement Caution: To maintain compliance with the FCC's RF exposure guidelines, place the product at least 20cm from nearby persons.

About the Instant Connect™ app!

Control your Instant Pot Pro Max using the Instant Connect App.

Get the App

You can download the app in one of two ways:

1. Scan the QR code below
2. Search “Instant Pot” in the Apple Store or the Google Play Store



Get connected

1. Plug in your appliance.
2. Open the App and select 'Get Started'.
3. Select 'Instant Pot Pro Max'.
4. The App will guide you through creating a user account.
5. Then the App will guide you through connecting.

For more details about the App and connecting, see page 17.

CONTENTS

Important safeguards	4
What's in the box	9
Using your Instant Pot Pro Max	12
Initial setup	15
Using the Instant Connect App	17
Using the lid	19
About pressure cooking	21
Pressure Cook	22
Rice	25
Steam	27
Slow Cook	29
Sauté	31
Sous Vide	33
Bake	35
Yogurt	37
Keep Warm	39
NutriBoost™	41
Delay Start	42
Timer	43
Maintenance	44
Cleaning	48
Troubleshooting	49
App Troubleshooting	51
Error Codes	53
Replacement parts	54
Learn more	55
Warranty	56

IMPORTANT SAFEGUARDS

⚠ WARNING

Failure to follow safety instructions may result in personal injury and/or property damage and may void your warranty.

READ ALL INSTRUCTIONS

Before using your new appliance, please read all instructions, including the Safety Information below. Keep this manual for reference.

Placement

- **DO** place the appliance on a countertop only. Always operate the appliance on a stable, non-combustible, level surface.
- **DO** make sure all parts are dry and free of food debris before placing the inner cooking pot on the cooker base.
- **DO NOT** place the appliance or power cord on or close to a gas or electric stovetop or oven. **NEVER** use the appliance on your stove.
- **DO NOT** use the appliance near water, an external heat source or flame.
- **DO NOT** use outdoors. Keep out of direct sunlight.
- **DO NOT** place on anything that may block the vents on the bottom of the appliance.

General Use

The removable inner cooking pot is extremely hot during use and can be extremely heavy when full of ingredients.

- **DO** use oven mitts when handling the inner cooking pot and removing accessories.
- **DO** place hot accessories on a heat-resistant surface or cooking plate.
- **DO** use care when lifting the cooking pot from the cooker base to avoid burn injury.
- **DO** use extreme caution when the cooking pot contains hot food, hot oil or other hot liquids.
- **DO** use only the Instant Pot lid that came with this cooker base. Using any other pressure cooker lids may cause personal injury and/or property damage.

⚠ WARNING

Failure to follow safety instructions may result in personal injury and/or property damage and may void your warranty.

- **DO NOT** use the appliance without the removable inner cooking pot installed.
- **DO NOT** touch the appliance's hot surfaces, or any accessories during or immediately after cooking because they will be hot. Only use the appliance's side handles for carrying or moving.
- **DO NOT** use this appliance for deep frying or pressure frying with oil.
- **DO NOT** move the appliance while it is in use and use extreme caution when disposing of hot grease.
- **DO NOT** allow children or persons with reduced physical, sensory or mental capabilities to operate this appliance. Close supervision is necessary when any appliance is used by or near children and persons with reduced physical, sensory or mental capabilities. Children should not play with this appliance.
- **DO NOT** use the appliance for anything other than household use. It is not intended for commercial use.
- **DO NOT** leave the appliance unattended while in use.

Pressure Cooking

This appliance cooks under pressure. Allow the appliance to depressurize naturally or release all excess pressure before opening.

Failure to follow these instructions may result in burns, personal injury and/or property damage.

- **DO** make sure the appliance is properly closed before operating.
- **DO** check that the steam release valve is installed properly.
- **DO** use the pressure cooking lid when pressure cooking.
- **DO** turn the appliance off if steam escapes from the steam release valve and/or float valve in a steady stream for longer than 3 minutes. If steam escapes from the sides of the lid, turn the appliance off. Once steam stops, pressure is released and the cooker has cooled, carefully make sure the sealing ring is properly installed.
- **DO** ensure the sealing ring is in good condition and installed properly before each use.
- **DO** check the steam release valve, steam release pipe, anti-block shield and float valve for clogging before use.

⚠ WARNING

• **DO NOT** remove the pressure cooking lid with unprotected hands.
Failure to follow safety instructions may result in personal injury and/or property damage and may void your warranty.

- **DO NOT** attempt to force the lid off the Instant Pot cooker base.
- **DO NOT** move the appliance when it is pressurized.
- **DO NOT** cover or obstruct the steam release valve and/or float valve with cloth or other objects.
- **DO NOT** attempt to open the appliance until it has depressurized, and all internal pressure has been released. Attempting to open the appliance while it is still pressurized may lead to sudden release of hot contents and may cause burns, personal injury and/or property damage.
- **DO NOT** place your face, hands or exposed skin over the steam release valve or float valve when the appliance is in operation or has residual pressure, and do not lean over the appliance when removing the lid.

Overfill During Pressure Cooking

Overfilling may cause a risk of clogging the steam release pipe and valve, developing excess pressure.

- **DO NOT** fill the inner cooking pot over the line labeled 'PC MAX' or 'Max PC Fill'.
- **DO NOT** fill the inner cooking pot over the line labeled '1/2' when cooking foods that expand during cooking such as rice, dried beans or dried vegetables.
- **DO** be aware that certain foods, such as applesauce, cranberries, pearl barley, oatmeal or other cereals, split peas, noodles, macaroni, rhubarb, or spaghetti can foam, froth and sputter, and clog the steam release pipe and valve. **DO NOT** fill the inner cooking pot over the line labeled '1/2' when cooking these foods.
- **DO NOT** place oversized foods into the inner cooking pot as they may cause risk of fire, personal injury and/or property damage.

Accessories

- **DO** use only accessories or attachments authorized by Instant Pot Brands. The use of parts, accessories or attachments not recommended by the manufacturer may cause a risk of electric shock or other personal injury, fire and/or property damage.

⚠ WARNING

Failure to follow safety instructions may result in personal injury and/or property damage and may void your warranty.

- **DO** use only an authorized Instant Pot inner cooking pot to reduce the risk of pressure leakage.
- **DO** only replace the sealing ring with an authorized Instant Pot sealing ring to prevent personal injury, property damage, and/or damage to the appliance.
- **DO NOT** use the included accessories in a microwave, toaster oven, convection or conventional oven, on a ceramic, electric or gas cooktop, or with an outdoor grill.

Care and Storage

- **DO** let the appliance cool to room temperature before cleaning or storage.
- **DO NOT** store any materials, other than the inner cooking pot, in the cooker base when not in use.
- **DO NOT** place any combustible materials in the cooker base, such as paper, cardboard, plastic, Styrofoam or wood.

Power Cord

A short power-supply cord is used to reduce the hazards resulting from grabbing, entanglement or tripping. **WARNING:** Hot spilled food can cause serious burns.

- **DO** keep appliance and power cord away from children.
- **DO NOT** let the power cord hang over edges of tables or counters.
- **DO NOT** let the power cord touch hot surfaces or open flame, including a stovetop.
- **DO NOT** use below-counter power outlets.

This appliance has a 3-prong grounding plug. To reduce the risk of electric shock:

- **ONLY** plug the power cord into a grounded electrical outlet.
- **DO NOT** remove the grounding prong on the electrical plug.
- **DO NOT** use with extension cords, power converters or adapters, timer switches or separate remote-control systems.

If the unit includes a detachable power cord:

- To connect, always attach the power cord to the appliance first, then plug the power cord into the wall outlet.

⚠ WARNING

Electrical Cautions

The cooker base contains electrical components that are an electrical shock hazard. **Failure to follow these instructions may result in electric shock and/or death.**

To protect against electrical shock:

- To disconnect, select **Cancel**, then remove plug from power source. Always unplug when not in use, as well as before adding or removing parts or accessories, and before cleaning. To unplug, grasp the plug and pull from the outlet. **NEVER** pull from the power cord.
- **DO** regularly inspect the appliance and power cord for any signs of damage or fraying.
- **DO NOT** operate the appliance if the power cord or plug is damaged, or after the appliance malfunctions or is dropped or damaged in any manner. For assistance, contact Consumer Care by email at **support@instantpot.com**.
- **DO NOT** attempt to repair, replace or modify components of the appliance, as this may cause electric shock or other personal injury, fire and/or property damage, and will void the warranty. For assistance, contact Consumer Care by email at **support@instantpot.com**.
- **DO NOT** tamper with any of the safety mechanisms, as this may result in personal injury and/or property damage.
- **DO NOT** put liquid or food of any kind into cooker base without the inner cooking pot.
- **DO NOT** immerse the power cord, plug or the appliance in water or other liquid.
- **DO NOT** clean the appliance by rinsing it under a faucet.
- **DO NOT** use the appliance in electrical systems other than 120 V ~ 60 Hz for North America.

SAVE THESE INSTRUCTIONS

⚠ WARNING

Failure to follow safety instructions may result in personal injury and/or property damage and may void your warranty.

WHAT'S IN THE BOX

Lid (top)

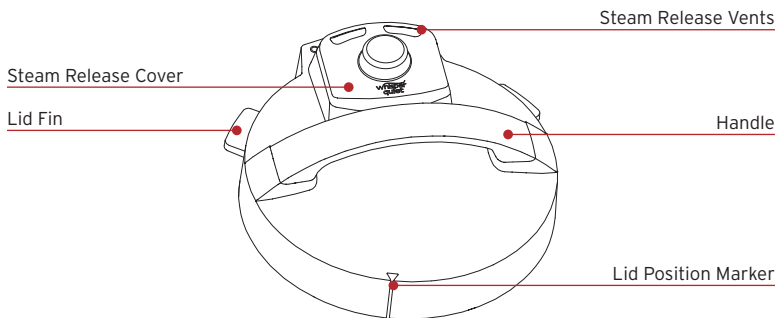

Lid (bottom)

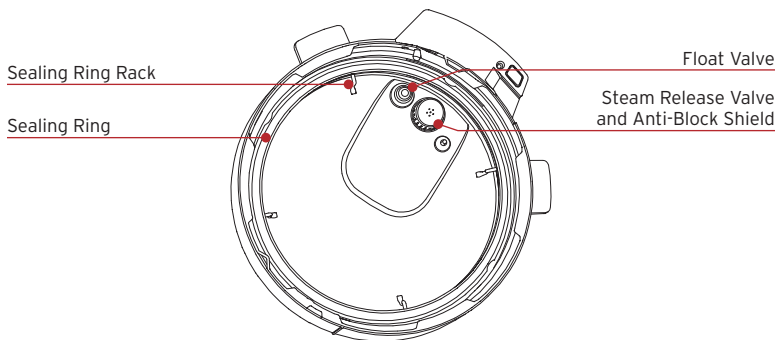

Illustrations are for reference only and may differ from the actual product.

Cooking Pot

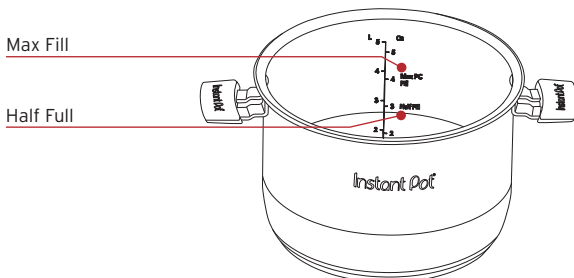

Cooker Base

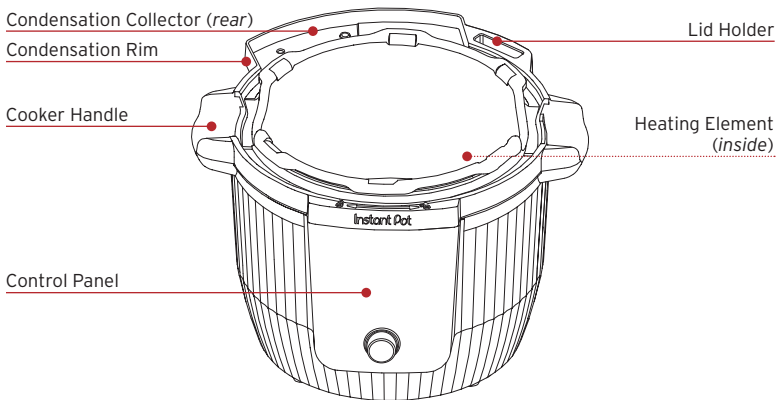

Illustrations are for reference only and may differ from the actual product.

Accessories

Steam Rack

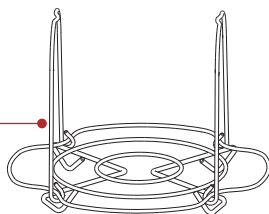

Extra Sealing Ring

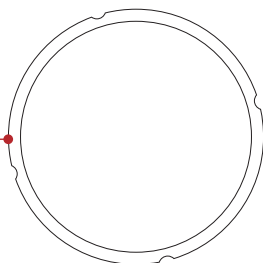

Condensation Collector

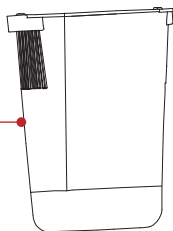

Remember to recycle!

We designed this packaging with sustainability in mind. Please recycle everything that can be recycled where you live.

USING YOUR INSTANT POT PRO MAX

Control panel

We've designed the control panel to be simple to use and easy to read.

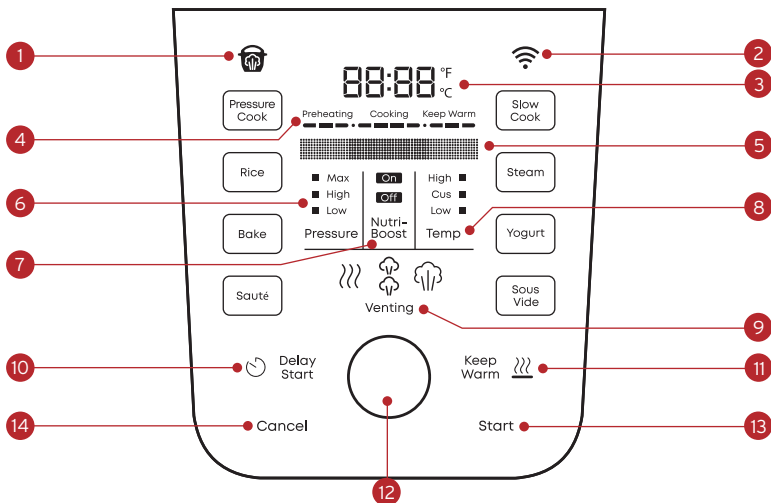

1. Pressure Indicator
 - When lit, indicates pressure in the multi-cooker
2. WiFi indicator
 - When lit bright white, unit paired with App
 - When lit orange, WiFi connection failed
 - When lit dim white, WiFi is off
3. Time and Temperature Display
 - Counts down for cooking
 - Counts up for Keep Warm
 - Shows custom temperature settings
 - Choose Fahrenheit or Celsius
4. Progress Bar
 - Shows cooking progress at-a-glance
5. Message Bar
 - Shows status and Smart Program instructions
6. Pressure
 - Choose High, Low or Max
7. NutriBoost
 - Choose On or Off
8. Temperature
 - Choose High, Low or Custom
9. Venting Options
 - Natural release
 - Pulse release
 - Quick release
10. Delay Start
 - Choose On or Off
 - Can also be used as kitchen timer
11. Keep Warm
 - Choose On or Off
12. Control Dial
 - Adjust time, temperature, pressure settings
13. Start
14. Cancel

Turning the sound On/Off

You set the alert sounds to either ON or OFF.

1. When the Message Bar shows **Ready**, press and hold **Delay Start** and the **Control Dial** for 5 seconds.
2. The Message Bar shows **Sound On** or **Sound Off**.
3. Repeat as needed.

Audible safety alerts (beeps) cannot be turned off.

Choosing the temperature scale

You can choose to show cooking temperature in either Fahrenheit or Celsius.

1. When the Message Bar shows **Ready**, press and hold **Keep Warm** and the **Control Dial** for 5 seconds.
2. The Message Bar shows **Temp Unit F** or **Temp Unit C**.
3. Repeat as needed.

Cooking temperature will now show in the scale you chose.

Cancel cooking

When in Preheating, Cooking or Keep Warm modes, press **Cancel**. The Message Bar shows **Ready**.

Memorized settings

Each time you use a Smart Program, the multi-cooker memorizes the settings you select and they become the default the next time you use that program. Each time you use a Smart Program, you can use the default settings or change them. This applies to:

- Pressure settings
- Temperature settings
- Steam release settings
- NutriBoost™ settings

Reset Smart Programs to original settings

You can erase all of the memorized settings and reset them to the original settings.

Reset Individual Smart Programs

- When the Message Bar shows **Ready**, press and hold one Smart Program button for over 3 seconds until the Smart Program flashes twice and the multi-cooker returns to Ready mode.
- When a Smart Program is in operation, press and hold the current Smart Program button until the cooking time and temperature settings return to the factory defaults.

Reset All Smart Programs

- When the Message Bar shows **Ready**, press and hold the **Control Dial** until all Smart Program buttons flash 3 times.

All Smart Program settings are restored to the factory defaults.

INITIAL SETUP

Clean and assemble before use

1. Hand wash the cooking pot, lid and sealing ring in warm water with soap. Rinse and use a soft cloth to dry the outside. Or you can wash the cooking pot in the dishwasher.
2. Wipe the heating element inside the multi-cooker base with a soft cloth to ensure there are no stray packaging particles.
3. Install the condensation collector. See the instructions on page 47.

Test run

Setting up your new Instant Pot for a test run is a great way to familiarize yourself with how the multi-cooker works before you actually cook a meal.

To perform a test run:

1. Add 3 cups water to the cooking pot.
 2. Place the cooking pot into the multi-cooker base.
 3. Place the lid on top of the multi-cooker base.
See 'How to close the lid' on page 19.
 4. Press **Pressure Cook**.
 5. Press **Pressure** to select **High** pressure level.
 6. Press the **minutes field** to activate it, then turn the **Control Dial** to select 5 minutes.
 7. Press **Keep Warm** to turn off the Keep Warm setting.
 8. Press the **venting field** to select **Quick** pressure release.
 9. Press **Start**. The progress bar and Message Bar show **Preheating**.
 10. When the pressure is ready, the Progress Bar shows **Cooking** and Message Bar shows **Don't Open Lid**. When the timer reaches 00:00, cooking stops.
 11. Venting begins automatically. When all steam is released, the Message Bar shows **OK to Open Lid**.
 12. Open the lid.
See 'How to open the lid' on page 19.
 13. Discard any remaining water, and then wash and dry the cooking pot.
- Now you're ready to cook a meal in your Instant Pot!

USING THE INSTANT CONNECT APP

Make cooking simple and easy when you control your Instant Pot Pro Max using the Instant Connect App from your mobile device.

Guided recipes

With over 2,000 delicious, tested recipes, the App's step-by-step virtual guide assists you through the entire cooking process, ensuring a tasty meal every time.

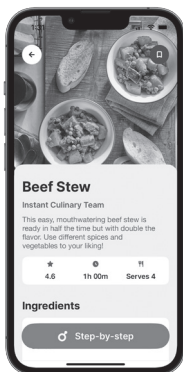

Discover 2,000 delicious recipes in the App

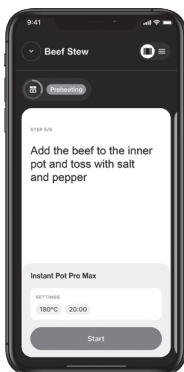

Use the App to interactively control cooking from within the recipe

Powered by



Control your Instant Pot

Use the App to control the Smart Programs on your Instant Pot. You can choose your own settings and save them, all remotely.

Monitor cooking remotely

Use the App to monitor every stage of the recipe from anywhere, knowing your meal will be ready when you are.

How to get the App

You can download the app in one of two ways:

- Scan the QR code below
- Search “Instant Pot” in the Apple Store or the Google Play Store



Pairing with the Instant Connect™ App

Read the “Requirements for pairing” section below before you start.

1. Plug in your appliance.
2. Open the App and select ‘Get Started’.
3. Select ‘Instant Pot Pro Max’.
4. The App will guide you through creating a user account.
5. **Then the App will guide you through connecting.**

Now you’re ready to begin using the App with your Instant Pot Pro Max!

Requirements for pairing





- We suggest you have the latest iOS version or Android version on your device for the best connectivity.
- Know your home WiFi network name and password.
- Make sure your Instant Pot Pro Max is plugged in and not currently cooking. It should display READY.
- Make sure you have your mobile device near the Instant Pot Pro Max.

Note: If the Wifi symbol blinks in orange, the connection failed.

USING THE LID



You'll use the lid for most Smart Programs, and always for pressure cooking. Always use the lid that came with this Instant Pot multi-cooker.

How to close the lid

1. Line up the  on the lid with the  on the multi-cooker base.
2. Turn the lid until the  on the lid aligns with the  on the cooker base.

For pressure cooking, the lid will automatically lock when the multi-cooker starts building pressure.

How to open the lid

1. If you're using a pressure cooking Smart Program, make sure to vent the steam first until the Pressure Indicator light turns off and the Message Bar shows **OK to Open Lid**.
2. Turn the lid counterclockwise until the  on the lid lines up with the  on the multi-cooker base.
3. Carefully lift the lid up and off the multi-cooker base.

How to release steam

Instant Pot Pro Max can release steam in 3 different ways. Use the one that best fits the type of food you're cooking or the recipe calls for.

Natural steam release

Releases steam gradually over time (up to 40 minutes or more) after cooking stops.

Use for: Foods that can simmer, like stews, chili, pasta and beans.

1. Press **Venting** until Natural release icon  lights.
2. Steam is released gradually.
3. When all steam is released, the Pressure Indicator light turns off.

WARNING

Failure to adhere to safety instructions may result in personal injury and/or property damage and may void your warranty.

Pulse steam release

Releases steam in bursts after cooking stops.

Use for: Foods like rice and grains.

1. Press **Venting** until Pulse release icon  lights.
2. Steam is released in short bursts.
3. When all steam is released, the Pressure Indicator light turns off.

Quick steam release

Quickly releases steam after cooking stops.

Use for: Foods that tend to overcook, like vegetables and seafood.

1. Press **Venting** until Quick release icon  lights.
2. Steam is released in a single burst.
3. When all steam is released, the Pressure Indicator light turns off.

*If you see a lot of spatter while Quick releasing pressure, press the **venting field** to return to Natural, **then touch Start**. Wait a few minutes before trying to release pressure again. If the spatter continues, use Natural steam release to safely release the remaining pressure.*

Changing the steam release method

For some recipes, you may start with one method of steam release, and change to another method to finish.

1. During steam release, press **Venting** repeatedly until the steam release method you want lights.
2. **Press Start.**
3. When all steam is released, the Pressure Indicator light turns off.

⚠ CAUTION

This appliance uses pressure to cook. Allow the appliance to release all excess pressure and steam before opening the lid. Opening the lid before pressure is released may result in burns, personal injury and/or property damage. Read more in the Safety, Maintenance and Warranty sections.

ABOUT PRESSURE COOKING

Pressure cooking uses pressure to raise the temperature in the cooking pot, allowing you to cook food much faster than normal. When pressure cooking, the Instant Pot goes through 3 stages.

Pre-heating

While the multi-cooker pre-heats, it heats the liquid to create steam. Once enough pressure has built up, the lid locks in place and the multi-cooker is ready to start cooking.

Cooking

When the multi-cooker reaches the required pressure level, cooking begins and keeps the pressure level consistent throughout cooking. See the Smart Program instructions starting on page 22 for details.

Steam release

When food has finished cooking, the multi-cooker is still pressurized and hot. Venting releases the pressure, lowers the temperature and allows you to safely remove the lid.

See How to release steam on pages 19-20.

⚠ WARNING

Failure to adhere to safety instructions may result in personal injury and/or property damage and may void your warranty.

PRESSURE COOK

Pressure cooking uses pressurized steam to quickly and evenly cook foods. You can adjust the settings as your recipe directs.

Choose from these settings in the Pressure Cook Smart Program. The program uses the default settings or the settings you selected the last time you used the Pressure Cook program.

Default Cook Time	Min Cook Time	Max Cook Time	Default Pressure Level	Pressure Level Options
10 minutes (00:10)	0 minutes (00:00)	4 hours (04:00)	High	Max High Low

Other settings

- Keep Warm is set to ON by default.
- Delay Start is available.
- NutriBoost™ is available (see page 41).

Use the app

You can control settings for the Pressure Cook program and use recipes for specific foods in the Instant Connect App. Or you can follow the instructions below, using the multi-cooker's Control Panel.

How to pressure cook

Prep

Cut, chop, season or marinate your ingredients according to your recipe.

Preheat

1. Place the cooking pot into the multi-cooker base and add ingredients and liquid.
2. Place the lid on top of the multi-cooker base and lock the lid.
3. Press **Pressure Cook**.
4. Press **Pressure** to toggle between **Low**, **High** and **Max** pressure levels.

5. Press the **hours field**, or the **minutes field** to activate them, then turn the **Control Dial** to select the time.
6. Press the **venting field** to toggle between **Natural**, **Pulse** and **Quick** pressure release options.
7. If you want to activate NutriBoost, press the **NutriBoost field** to turn it ON.
8. If you want to delay cooking, press **Delay Start**, then turn the **Control Dial** to select the delay time.
9. If you don't want to use Keep Warm, press **Keep Warm** to turn it OFF.
10. Press **Start**. The progress bar and Message Bar show **Preheating**.
It can take 15 minutes or more to reach the pressure setting for cooking. Frozen foods and large quantities increase the preheating time.

Cook

1. When the pressure is ready, the Progress Bar shows **Cooking** and Message Bar shows **Don't Open Lid**.
2. The cooking timer starts counting down.
*You can press **Cancel** to stop cooking and cancel the Smart Program at any time.*
*You can press **Keep Warm** at any time during cooking to turn it off.*

Stop cooking

1. When the timer reaches 00:00, cooking stops.
2. If Keep Warm is ON, the timer starts counting up. When Keep Warm time is finished, the Message Bar shows **End**.
*You can press **Cancel** at any time to stop Keep Warm. If you cancel before venting is finished, the Message Bar shows **Don't Open Lid**.*
3. Venting begins automatically.
You can change the venting method at any time.
4. When all steam is released, the Message Bar shows **OK to Open Lid** and **END**.

Using liquid to create steam

Pressure cooking requires liquid in the cooking pot to produce the steam needed. Here are the minimum amounts you'll need:

Instant Pot Size	Minimum Liquid for Pressure Cooking*
6 Quarts / 5.7 Litres	1 1/2 cups (12 oz / 375 mL)

**Unless otherwise specified in recipe.*

Pressure cooking liquids should be water-based, such as broth, stock, soup or juice. If using canned, condensed, or cream-based soup, add water as directed above.

Canning using pressure cooking

Your Instant Pot may be able to be used for canning, but with some limits.

- Canning requires a minimum of 15 psi for safe canning of low-acid foods, such as meat.
- Most Instant Pot electric pressure cookers operate within a range of 10-12 psi, which is safe for water bath canning of high-acid foods, such as jams and chutney.
- Modifying cooking times, ingredients or temperatures can be dangerous. Use the exact time, temperature/pressure and method specified in the recipe to protect the food from harmful bacteria, molds, and enzymes. Read and carefully follow the instructions provided in the USDA's ***Complete Guide to Home Canning***.
- **CAUTION:** If you live in a high-altitude area (above 6,600 ft), the altitude affects the ability of your Instant Pot to build up pressure. **DO NOT** use your Instant Pot to can in high-altitude areas.

⚠ WARNING

Failure to adhere to safety instructions may result in personal injury and/or property damage and may void your warranty.

RICE

The Rice Smart Program uses pressurized steam to cook rice quickly and evenly. You can adjust the settings as your recipe directs.

Choose from these settings in the Rice Smart Program. The program uses the default settings or the settings you selected the last time you used the Rice program.

Default Cook Time	Min Cook Time	Max Cook Time	Default Pressure Level	Pressure Level Options
12 minutes (00:12)	0 minutes (00:00)	1 hour (01:00)	Low	High Low

Other settings

- Keep Warm is set to ON by default.
- Delay Start is available.
- NutriBoost™ is available (see page 41).

Use the app

You can control all the settings for the Rice program and use recipes for specific foods in the Instant Connect App. Or you can follow the instructions below, using the multi-cooker's Control Panel.

How to cook rice

Preheat

1. Place the cooking pot into the multi-cooker base and add ingredients and liquid.
2. Place the lid on top of the multi-cooker base and lock the lid.
3. Press **Rice**.
4. Press **Pressure** to toggle between **Low** and **High** pressure levels.
5. Press the **hours** field, or the **minutes** field to activate them, then turn the **Control Dial** to select the time.

6. Press the **venting field** to toggle between **Natural**, **Pulse** and **Quick** pressure release options.
7. If you want to activate NutriBoost, press the **NutriBoost field** to turn it ON.
8. If you want to delay cooking, then turn the **Control Dial** to select the delay time.
9. If you don't want to use Keep Warm, press **Keep Warm** to turn it OFF.
10. Press **Start**. The progress bar and Message Bar show **Preheating**.

It can take 10 or more minutes to reach the correct setting for cooking.

Cook

1. When the pressure is ready, the Progress Bar shows **Cooking** and Message Bar shows **Don't Open Lid**.
2. The cooking timer starts counting down.

*You can press **Cancel** to stop cooking and cancel the Smart Program at any time.*

Stop cooking

1. When the timer reaches 00:00, cooking stops.
2. If Keep Warm is ON, the timer starts counting up. When Keep Warm time is finished, the Message Bar shows **End**.

*You can press **Cancel** at any time to turn it off. If you cancel before venting is finished, the Message Bar shows **Don't Open Lid**.*

3. Venting begins automatically.
You can change the venting method at any time.
4. When all steam is released, the Message Bar shows **OK to Open Lid** and **END**.

STEAM

Use Steam as you would a regular stovetop steamer, boiling liquid to cook food with hot steam. The Steam Smart Program does not use pressure to cook.

Choose from these settings in the Steam Smart Program. The program uses the default settings or the settings you selected the last time you used the Steam program.

Default Cook Time	Min Cook Time	Max Cook Time
10 minutes (00:10)	1 minute (00:01)	1 hour (01:00)

Other settings

- Keep Warm is not available.
- Delay Start is available.

Use the app

You can control all the settings for the Steam program and use recipes for specific foods in the Instant Connect App. Or you can follow the instructions below, using the multi-cooker's Control Panel.

How to steam

Prep

Cut or chop your ingredients according to your recipe.

Preheat

1. Place the cooking pot into the multi-cooker base and add a minimum of 12oz of water.
2. Add the steam rack and place the ingredients on top.
3. Place the lid on top of the multi-cooker base and lock the lid.
4. Press **Steam**.

5. Press the **hours field**, or the **minutes field** to activate them, then turn the **Control Dial** to select the time.
6. If you want to delay cooking, press **Delay Start**, then turn the **Control Dial** to select the delay time.
7. Press **Start**. The progress bar and Message Bar show **Preheating**.
It can take 10-15 minutes to reach the temperature for cooking. Frozen foods increase the preheating time.

Cook

1. When the temperature is ready, the Progress Bar shows **Cooking**.
2. The cooking timer starts counting down.
*You can press **Cancel** to stop cooking at any time.*

Stop cooking

1. When the timer reaches 00:00, cooking stops. The Message Bar shows **End** and **OK to Open Lid**.

SLOW COOK

Slow Cook lets you make your favorite simmering and stewing recipes, just as you would in a slow cooker. This Smart Program does not use pressure to cook food.

Choose from these settings in the Slow Cook Smart Program. The program uses the default settings or the settings you selected the last time you used the Slow Cook program.

Default Temperature	Temperature Options	Min Cook Time	Max Cook Time
High	High Low	30 minutes (00:30)	24 hours (24:00)

Other settings

- Keep Warm is ON by default.
- Delay Start is available.

Use the app

You can control all the settings for the Slow Cook program and use recipes for specific foods in the Instant Connect App. Or you can follow the instructions below, using the multi-cooker's Control Panel.

How to slow cook

Prep

Cut, chop, season or marinate your ingredients according to your recipe.

Cook

1. Place the cooking pot into the multi-cooker base and add ingredients.
2. Place the lid on top of the multi-cooker base and lock the lid.
3. Press **Slow Cook**.

4. Press the **temperature field** to toggle between **Low** and **High** temperature options.
5. Press the **hours field**, or the **minutes field** to activate them, then turn the **Control Dial** to select the time.
6. If you don't want to use Keep Warm, press **Keep Warm** to turn it OFF.
7. If you want to delay cooking, press **Delay Start**, then turn the **Control Dial** to select the delay time.
8. Press **Start**. The Progress Bar shows **Cooking**.
9. The cooking timer starts counting down.
*You can press **Cancel** to stop cooking at any time.*

Stop cooking

1. When the timer reaches 00:00, cooking stops. The Message Bar shows **OK to Open Lid**.
2. If Keep Warm is ON, the timer starts counting up.
*Press **Cancel** at any time to turn it off.*

SAUTÉ

Use Sauté in place of a frying or saucepan. Sautéing can deepen the flavors of your food, or can simmer, thicken or reduce sauces.

Choose from these settings in the Sauté Smart Program. The program uses the default settings or the settings you selected the last time you used the Sauté program.

Default Temperature	Temperature Options	Default Cook Time	Min Cook Time	Max Cook Time
High	High Low Custom	30 minutes (00:30)	1 minute (00:01)	1 hour (01:00)

To help determine what setting to choose, these are the actual temperatures:

Temperature Level	Temperature
High	190°C / 374°F
Low	105°C / 221°F
Custom 1	95°C / 203°F
Custom 2	110°C / 230°F
Custom 3	135°C / 275°F
Custom 4	160°C / 320°F
Custom 5	185°C / 365°F
Custom 6	190°C / 374°F

Other settings

- Keep Warm is not available.
- Delay Start is not available.

How to sauté

Prep

Cut, chop, season or marinate your ingredients according to your recipe.

Preheat

1. Place the cooking pot into the multi-cooker base.
2. Press **Sauté**.
3. Press the **temperature field** to toggle between **Low**, **High** and **Custom** temperature options.
4. If you selected Custom, turn the **Control Dial** to select the temperature level.
5. Press the **hours field**, or the **minutes field** to activate them, then turn the **Control Dial** to select the time.
6. Press **Start**. The Progress Bar shows **Preheating**.

Cook

1. When the Message Bar shows **Add Food**, add ingredients.
Do not use the lid while sauteing.
2. When the cooking time reaches 00:00, the Message Bar shows **End**.
*You can press **Cancel** to stop cooking at any time.*

Sautéing before Pressure or Slow Cooking

Quite often, you'll want to sauté foods to brown them before further cooking them.

1. Sauté ingredients.
2. Press **Cancel**.
*You can deglaze the cooking pot now before switching to **Pressure Cook** or **Slow Cook** (see **Deglazing** below)*
3. Select the Smart Program you want to use to cook.

Deglazing

Deglazing is the process of adding a liquid to a hot pan, releasing all of the delicious, caramelized pieces stuck to the bottom.

1. Remove food from cooking pot.
2. Add water, broth, or wine.
3. Use wooden spoon or silicone spatula to loosen food stuck to bottom of the cooking pot.

SOUS VIDE

Sous Vide cooks food underwater in an air-tight, food-safe bag, for a long period of time. Food cooks in its own juices and comes out delicious and very tender. This Smart Program does not use pressure to cook food.

Choose from these settings for the Sous Vide Smart Program. The program uses the default settings or the settings you selected the last time you used the Sous Vide program.

Default Temperature	Min Temperature	Max Temperature	Default Cook Time	Min Cook Time	Max Cook Time
56°C 133°F	25°C 77°F	90°C 194°F	3 hours (03:00)	30 minutes (00:30)	99 hours, 30 minutes (99:30)

Other settings

- Keep Warm is not available.
- Delay Start is not available.

What you need to sous vide

- Tongs
 - Food safe, airtight, re-sealable food pouches
- OR
- Vacuum sealer and food-safe vacuum bags

Use the app

You can control all the settings for the Sous Vide program and use recipes for specific foods in the Instant Connect App. Or you can follow the instructions below, using the multi-cooker's Control Panel.

How to sous vide

Prep

1. Cut, chop, season or marinate your ingredients according to your recipe.
2. Add the ingredients to the cooking bag or pouch and seal tightly.

Preheat

1. Fill the cooking pot with water to the [1/2] mark.
2. Place the cooking pot into the multi-cooker base.
3. Place the lid on top of the multi-cooker base and lock the lid.
4. Press **Sous Vide**.
5. Press the **hours field**, **then minutes field** to activate them, then turn the **Control Dial** to select the time.
6. Press the **temperature field** to activate it, then turn the **Control Dial** to select the temperature.
7. Press **Start**. The Progress Bar shows **Preheating**.

Cook

1. When the Progress Bar shows **Add Food**, open the lid, add the cooking bag or pouch to the cooking pot, then close the lid again.
2. The cooking time starts counting down.
3. When the cooking time reaches 00:00, the Message Bar shows **End**.
*You can press **Cancel** to stop cooking at any time.*

Remove food

1. When cooking is done, press the **venting field** to select **Quick** pressure release.
The Sous Vide Smart Program does not use pressure to cook, but a small amount of pressure can build up and make it hard to remove the lid.
2. Remove the lid and use the tongs to carefully remove the cooking pouch.

BAKE

You can use Bake to cook foods like cheesecake, pudding cake, baked fruits and cobblers.

Choose from these settings in the Bake Smart Program. The program uses the default settings or the settings you selected the last time you used the Bake program.

Default Pressure	Pressure Options	Default Cook Time	Min Cook Time	Max Cook Time
High	High Low	15 minutes (00:15)	0 minutes (00:00)	2 hours (02:00)

Other settings

- Keep Warm is set to OFF by default.
- Delay Start is available.

Use the app

You can control all the settings for the Bake program and use recipes for specific foods in the Instant Connect App. Or you can follow the instructions below, using the multi-cooker's Control Panel.

How to bake

Prep

1. Prepare your ingredients according to your recipe.
2. Place the ingredients into an oven-safe baking dish that fits in the Instant Pot multi-cooker base.

Leave approximately 1"/ 2.5 cm of space around all sides of the baking dish to allow heat to circulate evenly.

Preheat

1. Place the cooking pot into the multi-cooker base.
2. Add 1 1/2-cups water to the cooking pot.
3. Place the steam rack inside the cooking pot and then place the baking dish on top of the steam rack.

4. Place the lid on top of the multi-cooker base.
5. Press **Bake**.
6. To change the pressure settings, press **Pressure** to toggle between **Low** and **High** pressure levels.
7. To change the cooking time, press the **hours field**, or the **minutes field** to activate them, then turn the **Control Dial** to select the time.
8. To change the pressure release method, press the **Venting** options to select **Natural**, **Pulse** or **Quick** release methods.
9. If you want to use Keep Warm, press **Keep Warm** to turn it ON.
10. If you want to delay cooking, press **Delay Start**, then turn the **Control Dial** to select the delay time.
11. Press **Start**. The progress bar and Message Bar show **Preheating**.

It can take 15 minutes or more to reach the pressure setting for cooking. Frozen foods and large quantities increase the preheating time.

Cook

1. When it's ready, the Progress Bar shows **Cooking** and the timer starts counting down.
2. Keep Warm setting is **Off** by default. Press **Keep Warm** at any time to turn it on.

*You can press **Cancel** to stop cooking and cancel the Smart Program at any time.*

Stop cooking

1. When the timer reaches 00:00, cooking stops.
2. If Keep Warm is ON, the timer starts counting up.
*You can press **Cancel** at any time to turn it off.*
3. Venting begins automatically.
You can change the venting method at any time.
4. When it's safe to open the lid, the Message Bar shows **End** and/or **OK to Open Lid**.

YOGURT

You can use your Instant Pot to easily make delicious, fermented dairy and non-dairy yogurt.

Choose from these settings in the Yogurt Smart Program:

Step	Temperature	Default Time	Min Time	Max Time
Pasteurization	85°C (185°F) Not adjustable	30 minutes (00:30)	Not adjustable	Not adjustable
Fermentation	41°C (106°F) Not adjustable	8 hours (08:00)	6 hours (06:00)	12 hours (12:00)

Other settings

- Keep Warm is not available.
- Delay Start is not available.

Use the app

You can control all the settings for the Yogurt program and use recipes for specific foods in the Instant Connect App. Or you can follow the instructions below, using the multi-cooker's Control Panel.

How to make yogurt

Pasteurizing Milk

1. Add ingredients to the cooking pot and insert cooking pot into the multi-cooker base.
2. Place the lid on top of the multi-cooker base and lock the lid.
3. Press **Yogurt**.
Pasteurization time and temperature are preset.
4. Press **Start**. The Progress Bar shows **Cooking** and the Message Bar shows **Step 1** and **Pasteurize**.
5. When it's done, pasteurizing stops. The Message Bar blinks **OPEN LID TO COOL DOWN**. When lid is removed the message bar shows **COOLING DOWN**.

Milk must reach a minimum of 161°F / 72°C for pasteurization to occur

Adding Culture/Starter

1. When the pasteurized milk has cooled sufficiently, the Message Bar shows **Add Starter**.
2. Remove the lid.
3. Add a starter culture to the milk according to package instructions.
If using plain yogurt as a starter, ensure that it contains an active culture. Mix in 2 tbsp (30 mL) of yogurt per 1 gallon (3.7 L) of milk or follow a trusted recipe.
4. Place the lid back on the multi-cooker base.

Ferment

1. Press the **hours field**, then minutes field to activate them, then turn the **Control Dial** to select the time.
A longer fermentation period will produce tangier yogurt.
2. Press **Start**. The Progress Bar shows **Cooking** and the Message Bar shows **Step 2** and **Ferment**.
3. When fermentation completes, the display shows **End**.
4. Open the lid and transfer the yogurt to a food storage container.
5. Place in the fridge for 12 - 24 hours to develop flavors.

How much to make?

Minimum Milk Volume	Maximum Milk Volume
4 Cups (32 oz / 1000 mL)	4 Quarts (128 oz / 3.8 L)

KEEP WARM

The Keep Warm setting turns on automatically after cooking on the Pressure Cook, Rice and Slow Cook Smart Programs. You can also use Keep Warm to reheat food.

Choose from these settings in the Keep Warm Smart Program. The program uses the default settings or the settings you selected the last time you used the Keep Warm program.

Keep Warm Temperature	Reheat Temperature Options	Default Time	Min Time	Max Time
High	Low High Custom Custom Min: 25°C / 77°F Custom Max: 95°C / 203°F	8 hours (08:00)	10 minutes (00:10)	10 hours (10:00)

How to keep warm after cooking

1. When cooking is finished, automatic warming begins. The timer shows the time passed, up to 10 hours.
2. To turn automatic warming off at any time, press **Cancel**.

How to reheat

Prep

Place the food to be reheated into the cooking pot.

Add 1 1/2 cups water to the cooking pot to avoid overheating, place the steam rack in the cooking pot, then place the baking dish on the steam rack.

Reheat

1. Place the cooking pot into the multi-cooker base.
2. Place the lid on top of the multi-cooker base.
3. Press **Keep Warm**.
4. Press the **hours field**, or the **minutes field** to activate them, then turn the **Control Dial** to select the time.
5. Press the **temperature field** to toggle to **High**, **Low** or **Custom**.
6. If you chose Custom temperature, turn the **Control Dial** to select a temperature.
7. Press **Start**. The Progress Bar shows **Keep Warm** and the Message Bar shows the temperature setting. The timer starts counting down.
8. When reheating completes, the display shows **End**. You can press **Cancel** at any time to stop the **Keep Warm** function.

NUTRIBOOST™

NutriBoost is a special setting that you can use during the Pressure Cook and Rice Smart Programs. It creates a boiling motion in the cooking pot that mimics the action of stirring. Just like stirring, this helps to enhance flavors, and improve textures. It's amazing for rich bone broth and creamy risotto!

To use NutriBoost

- After you've selected a Smart Program while cooking, press the **NutriBoost** field to turn it ON.
- If you change your mind, press the NutriBoost field to turn it OFF.

Smart Program	How it works
Rice	The multi-cooker releases short puffs of steam during the first 3 minutes of Cooking.
Pressure Cook	The multi-cooker releases short puffs of steam during the last 15 minutes of Cooking.

! CAUTION

To avoid food spatter and overflow, do not use NutriBoost when cooking starchy or foamy food like porridge, oatmeal, or pasta. The multi-cooker should be closely monitored when using NutriBoost.

DELAY START

You can set a Delay Start timer for a minimum of 10 minutes or a maximum of 24 hours (the default is 8 hours).

Delay Start is not available with the Sauté, Yogurt or Sous Vide Smart Programs.

Delay the start of cooking

1. Select a Smart Program, adjust the settings as you want, then press **Delay Start**.
2. Turn the **Control Dial** to select the delay time.
3. Press **Start**. The timer counts down.
4. When Delay Start ends, the Smart Program begins automatically, and the display indicates **Cooking Time**.

TIMER

Even when you're not using your Instant Pot for cooking, you can set a timer for a minimum of 1 minute or a maximum of 1 hour (the default is 10 minutes).

Set a timer (without cooking)

1. When the Message Bar shows **Ready**, press **Delay Start**.
2. Turn the **Control Dial** to select the delay time.
3. Press **Start** to begin the timer.

MAINTENANCE

Your Instant Pot Pro Max includes parts that enable pressure cooking. **These parts must be installed for pressure cooking to work properly and either cleaned or replaced regularly.**

⚠ WARNING

Failure to adhere to safety instructions may result in personal injury and/or property damage and may void your warranty.

Sealing ring

When the pressure cooking lid is closed, the sealing ring installed on the underside of the lid creates an air-tight seal between the lid and the multi-cooker base.

- The sealing ring must be installed before using the multi-cooker and should be cleaned after each use.
- Install 1 sealing ring at a time; use one for sweet dishes and one for savory.
- Sealing rings stretch over time with normal use. To keep your product safe, replace the sealing ring every 12 to 18 months. Replace sooner if you notice stretching, deformation, or damage.

Install the Sealing Ring

1. Place the sealing ring behind the sealing ring rack and press it into place. Press down firmly to ensure there is no puckering.

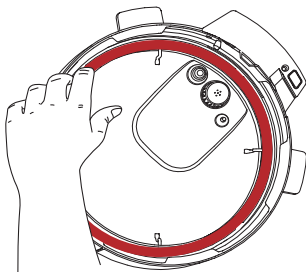

2. The sealing ring should be snug and should not fall out when the lid is turned over.

Remove the Sealing Ring

1. Grip the edge of the sealing ring and pull it out from behind the sealing ring rack.

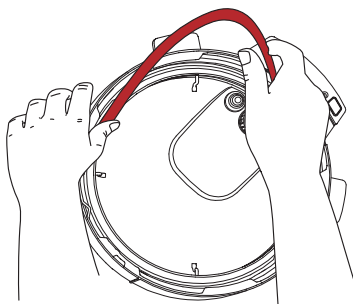

2. Inspect the rack to ensure it is secured, centered, and an even height all the way around the lid. If the sealing ring rack is deformed, do not try to repair it.

Anti-block shield

The anti-block shield prevents food particles from coming up through the steam release pipe, helping to regulate pressure.

As an integral part of product safety, the anti-block shield must be installed before use and cleaned frequently.

Remove the Anti-Block Shield

Turn the lid over and hold it securely with one hand. Use the other hand to grasp the Anti-Block Shield with your fingers and pull firmly to remove it from the prongs underneath.

Install the Anti-Block Shield

Place the anti-block shield over the prongs and press down until it snaps into position. Do not attempt to operate the pressure multi-cooker without the anti-block shield installed.

Steam release cover

When the multi-cooker releases pressure, steam ejects from the top of the steam release cover. The steam release cover and steam release valve are integral to product safety and necessary for pressure cooking. The cover and valve both must be installed before use and cleaned regularly.

⚠ WARNING

If the steam release cover and steam release valve are not installed, hot liquid will spatter out, which may lead to personal injury or property damage.

Remove the steam release assembly

Pull steam release cover off, then pull the steam release valve up and off steam release pipe.

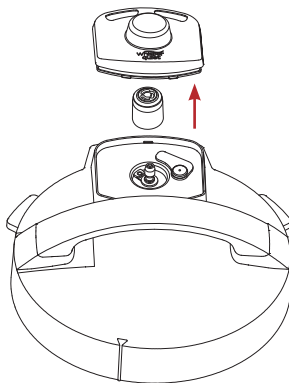

Install the steam release assembly

Place the steam release valve on the steam release pipe and press down firmly. Insert the tabs on the steam release cover into the holes on the lid and press down on the opposite side until the cover is seated.

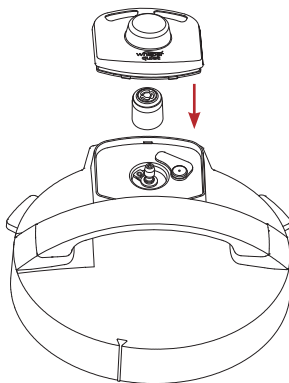

When installed properly, the steam release assembly is firmly attached to the lid. It should remain in place when the lid is turned over.

Setting up the condensation collector

The condensation collector sits at the back of the multi-cooker base and accumulates overflow moisture from the condensation rim. It should be installed before cooking, then emptied and rinsed out after each use.

Install the condensation collector

Align the grooves on the condensation collector with the tabs on the back of the multi-cooker base and slide the condensation collector into place.

Remove the condensation collector

Pull the condensation collector away from the multi-cooker base; do not pull down.

Note the tabs on the multi-cooker base and the grooves on the condensation collector.

CLEANING

Clean your Instant Pot after each use. Always unplug the unit and let all parts cool to room temperature before cleaning. Before use or storing, make sure all surfaces are dry.

Part	Cleaning instructions
Accessories <ul style="list-style-type: none">• Steam Rack	<ul style="list-style-type: none">• Wash after each use• Hand wash with hot water and mild dish soap or wash in dishwasher, top rack• Never use harsh chemical detergents, powders or scouring pads on accessories
Lid and Parts <ul style="list-style-type: none">• Anti-Block Shield• Sealing Ring• Steam Release Valve• Steam Release Cover• Condensation Collector	<ul style="list-style-type: none">• Hand wash with hot water and mild dish soap• Remove all small parts from lid before washing• With steam release valve and anti-block shield removed, clean interior of steam release pipe to prevent clogging• After cleaning, store the lid upside down on the multi-cooker base• Store sealing rings in a well-ventilated area to disperse odor• To eliminate odors from sealing ring, add 1 cup (8 oz / 250 mL) water and 1 cup (8 oz / 250 mL) white vinegar to cooking pot, and run Pressure Cook for 5-10 minutes, then use Quick Steam Release• Empty and rinse condensation collector after each use
Cooking Pot	<ul style="list-style-type: none">• Wash after each use• Hand wash with hot water and mild dish soap or wash in dishwasher*• Hard water stains may need a vinegar-dampened sponge and scrubbing to remove• For tough or burned food residue, soak in hot water for a few hours before cleaning• Dry all exterior surfaces before placing in multi-cooker base
Power cord	<ul style="list-style-type: none">• Use a barely-damp cloth to wipe any particles off cord
Cooker base	<ul style="list-style-type: none">• Wipe the inside of the multi-cooker base as well as the condensation rim with a barely-damp cloth, and allow to air dry• Clean the outside of the multi-cooker base and the control panel with a soft, barely-damp cloth or sponge

**Some discoloration may occur after machine washing, but this will not affect the multi-cooker's safety or performance.*

TROUBLESHOOTING

Problem	Cause	Solution
Difficulty closing lid	Sealing ring not properly installed	Reposition sealing ring, ensure it is snug behind sealing ring rack.
	Float valve is stuck in the popped-up position	Gently press the float valve downward with a long utensil.
Difficulty opening lid	Pressure inside the multi-cooker	Release pressure according to recipe; only open lid when the Message Bar shows OK to Open Lid .
	Float valve is stuck in the popped-up position due to food debris or residue	Make sure steam is completely released by quick releasing pressure, remove the steam release cover, then press the float valve gently with a long utensil. Open the lid cautiously, then thoroughly clean the float valve, surrounding area, and lid before next use.
Cooking pot is stuck to lid	Cooling of cooking pot may create suction, causing cooking pot to adhere to the lid	To release the vacuum, set Steam Release to Quick Release.
Steam leaks from side of lid	No sealing ring in lid	Install sealing ring.
	Sealing ring damaged or not properly installed	Replace sealing ring.
	Food debris attached to sealing ring	Remove sealing ring and clean thoroughly.
	Lid not closed properly	Open, then close lid.
	Sealing ring rack is warped or off-center	Remove sealing ring from lid, check sealing ring rack for bends or warps. Contact Consumer Care.
	Cooking pot rim may be misshapen	Check for deformation and contact Consumer Care.
Minor steam leaking/hissing from steam release vent during cooking cycle	Cooker is regulating excess pressure	This is normal; no action required.
Steam gushes from steam release vent when Steam Release switch is in Seal position	Not enough liquid in the cooking pot	Add thin, water-based liquid to the cooking pot: 1 1/2 cups (12 oz / 375 mL)
	Pressure sensor control failure	Contact Consumer Care.

Problem	Cause	Solution
Display remains blank after connecting the power cord	Bad power connection or no power	Inspect power cord for damage. If damage is noticed, contact Consumer Care. Check outlet to ensure it is powered.
	Cooker's electrical fuse has blown	Contact Consumer Care.
Occasional clicking or light cracking sound	The sound of power switching and expanding pressure board when changing temperatures	This is normal; no action needed.
	Bottom of the cooking pot is wet	Wipe exterior surfaces of cooking pot. Ensure heating element is dry before inserting cooking pot into multi-cooker base.
Error code appears on display and multi-cooker beeps continuously	There is an issue with the multi-cooker	Read "Error Codes" for instructions.

APP TROUBLESHOOTING

Problem	Solution
I tried to download the App, and it says my device is not compatible.	Make sure the version of iOS or Android operating systems on your mobile device is compatible with the App. These are listed on the Instant Connect page in the App Store and Google Play store.
I am trying to create an account in the App, but I have not received the verification code.	Check your spam or junk folder in your email account. If you find it, make sure to mark it as "not spam" to prevent future emails from being filtered. Wait a few minutes and check your inbox again; sometimes email is simply delayed. <i>Note: the validation email will come from our smart appliance technology partner, Fresco.</i>
My saved recipes have disappeared from my account in the App.	Saved recipes can be found under "My Cookbook," located at the bottom of the screen. If you don't see your recipes there, uninstall the App. Then download the latest version. You can download using the QR code inside the front cover of this manual. To help you make sure your recipes get saved, try the following: <ol style="list-style-type: none">1. Make sure you have a strong and stable WiFi connection. This will help the App communicate the server and save the recipe properly.2. Check that your device has enough storage space. If your device's storage is running low, the App may not be able to save the information properly.3. Check that the App has the necessary permissions to access your device's storage and network. If the App does not have the required permissions, it may not be able to save information properly.

Problem	Solution
<p>I am trying to sign in to the App, and my account cannot be found; I was able to sign in yesterday.</p>	<p>Check your login: Make sure you are using the correct email address and password associated with your account. Sometimes, small typos can prevent you from signing in. If you recently reset your password, make sure you're using new password.</p> <p>Clear the app cache and data: Sometimes, cached data can interfere with the sign in process. Open your device's settings and select Apps or Applications. Select the Instant Connect App and look for the option to clear the App's cache and data.</p> <p>Uninstall and reinstall the App: If you consistently cannot connect, uninstall the App. Then download the latest version. You can download using the QR code inside the front cover of this manual.</p>
<p>I've installed the App, but half the screen is cut off.</p>	<ol style="list-style-type: none"> 1. Adjust the screen resolution: Open your device's settings and select Display or Screen. Look for an option to adjust the screen resolution and try selecting a different resolution to see if that resolves the issue. 2. Increase the font size: If the type is too small and getting cut off, try increasing the font size in the App or in your device's settings. Open your device's settings and select Accessibility. Look for an option to adjust the font size. 3. If the issue persists in the Instant Connect App, try using a different app to see if the problem affects all apps on your device. 4. Clear the App's cache: Open your device's settings and select Apps or Applications. Select the Instant Connect App and look for the option to clear the App's cache. If you still can't view the App correctly, contact Consumer Care.



ERROR CODES

If the control panel shows an error code from this list, there is an issue with the Instant Pot. Here are the actions you should take to fix the problem.

Problem	Cause	Solution
C1	Faulty sensor	Contact Consumer Care.
C3	Faulty sensor	Contact Consumer Care.
C7	Not enough liquid.	Add clear liquid to the pot. (1 1/2 cups minimum)
C10	WIFI module failure.	Contact Consumer Care.
LID OPEN or CLOSE LID	Lid is not in the correct position for the selected program	Open and close the lid. Do not use a lid when using Sauté.
Food burn	High temperature detected at bottom of cooking pot; multi-cooker automatically reduces temperature to avoid overheating	Starch deposits at the bottom of the cooking pot may have blocked heat dissipation. Turn the multi-cooker off, release pressure according to the recipe, and inspect the bottom of the cooking pot.

REPLACEMENT PARTS

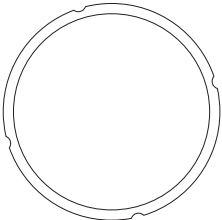
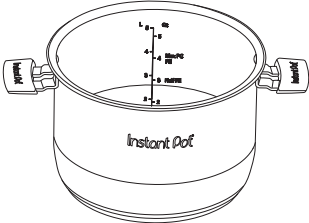
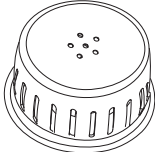
We offer genuine replacement parts for your Instant Pot Pro Max WiFi Multi-Cooker, if you need them. Visit www.instantpot.com to order.

	Part	Part number
	Sealing Ring	211-0001-01
	Inner Cooking Pot	212-0401-01
	Anti Block Shield	310-0006-01
	Steam Release Valve	310-0011-01
	Manual	399-1256-03US

LEARN MORE

There's a whole world of Instant® cooking information and help just waiting for you. Here are some of the most helpful resources.

Register your product

Instantpot.com/register

Contact Consumer Care

In the Instant Connect™ App
Instantpot.com/customer-care-center
support@instantpot.com

Download the Instant Connect™ App

Discover guided cooking and recipes
Available at iOS and Android app stores

Cooking charts and more recipes

Instantpot.com

How-to videos, tips and more

Instantpot.com

Replacement parts and accessories

Instantpot.com

Join the community



Product Specifications

Model	Volume	Wattage	Power
PRCPC601WE	6 Quarts 5.7 Litres	1200 W	120V/ 60 Hz

WARRANTY

One (1) Year Limited Warranty

This One (1) Year Limited Warranty applies to purchases made from authorized retailers of Instant Pot Brands by the original appliance owner and is not transferable. Proof of original purchase date and, if requested by Instant Pot Brands, return of your appliance, is required to obtain service under this Limited Warranty. Provided the appliance was used in accordance with the use & care instructions, Instant Pot Brands will, in its sole and exclusive discretion, either: (i) repair defects in materials or workmanship; or (ii) replace the appliance. In the event that your appliance is replaced, the Limited Warranty on the replacement appliance will expire twelve (12) months from the date of receipt. Failure to register your product will not reduce your warranty rights. The liability of Instant Pot Brands, if any, for any allegedly defective appliance or part will not exceed the purchase price of a comparable replacement appliance.

What is not covered by this warranty?

- Products purchased, used, or operated outside of the United States and Canada.
- Products that have been modified or attempted to be modified.
- Damage resulting from accident, alteration, misuse, abuse, neglect, unreasonable use, use contrary to the operating instructions, normal wear and tear, commercial use, improper assembly, disassembly, failure to provide reasonable and necessary maintenance, fire, flood, acts of God, or repair by anyone unless directed by an Instant Pot Brands representative.
- Use of unauthorized parts and accessories.
- Incidental and consequential damages.
- The cost of repair or replacement under these excluded circumstances.

EXCEPT AS EXPRESSLY PROVIDED HEREIN AND TO THE EXTENT PERMITTED BY APPLICABLE LAW, INSTANT POT BRANDS MAKES NO WARRANTIES, CONDITIONS OR REPRESENTATIONS, EXPRESS OR IMPLIED, BY STATUTE, USAGE, CUSTOM OF TRADE OR OTHERWISE WITH RESPECT TO THE APPLIANCES OR PARTS COVERED BY THIS WARRANTY, INCLUDING BUT NOT LIMITED TO, WARRANTIES, CONDITIONS, OR REPRESENTATIONS OF WORKMANSHIP, MERCHANTABILITY, MERCHANTABILITY, FITNESS FOR A PARTICULAR PURPOSE OR DURABILITY.

Some states or provinces do not allow for: (1) the exclusion of implied warranties of merchantability or fitness; (2) limitations on how long an implied warranty lasts; and/or (3) the exclusion or limitation of incidental or consequential damages; so these limitations may not apply to you. In these states and provinces, you have only the implied warranties that are expressly required to be provided in accordance with applicable law. The limitations of warranties, liability, and remedies apply to the maximum extent permitted by law. This limited warranty gives you specific legal rights, and you may also have other rights which vary from state to state or province to province.

Product Registration

Please visit www.instantpot.com/register to register your new Instant Pot Brands appliance. Failure to register your product will not diminish your warranty rights. You will be asked to provide the store name, date of purchase, model number (found on the back of your appliance) and serial number (found on the bottom of your appliance) along with your name and email address. The registration will enable us to keep you up to date with product developments and recipes, and contact you in the unlikely event of a product safety notification. By registering, you acknowledge that you have read and understand the instructions for use, and warnings set forth in the accompanying instructions.

Warranty Service

To obtain warranty service, please contact our Consumer Care Department by email to support@instantpot.com. You can also create a support ticket online at www.instantpot.com. If we are unable to resolve the problem, you may be asked to send your appliance to the Service Department for quality inspection. Instant Pot Brands is not responsible for shipping costs related to warranty service. When returning your appliance, please include your name, mailing address, email address, phone number, and proof of the original purchase date as well as a description of the problem you are encountering with the appliance.

IC STATEMENT

This device complies with Industry Canada license-exempt RSS standard(s). Operation is subject to the following two conditions: (1) this device may not cause interference, and (2) this device must accept any interference, including interference that may cause undesired operation of the device.

Le présent appareil est conforme aux CNR d'Industrie Canada applicables aux appareils radio exempts de licence. L'exploitation est autorisée aux deux conditions suivantes : (1) l'appareil ne doit pas produire de brouillage, et (2) l'utilisateur de l'appareil doit accepter tout brouillage radioélectrique subi, même si le brouillage est susceptible d'en compromettre le fonctionnement.

This equipment complies with IC radiation exposure limits set forth for an uncontrolled environment. This equipment should be installed and operated with minimum distance 20cm between the radiator & your body.

Cet équipement est conforme aux limites d'exposition aux rayonnements IC établies pour un environnement non contrôlé. Cet équipement doit être installé et utilisé avec un minimum de 20 cm de distance entre la source de rayonnement et votre corps.

⚠ WARNING

DO NOT place this appliance on or close to a gas or electric burner, or inside an oven. Always operate this appliance on a stable, non-combustible, level surface, such as a kitchen countertop.



In Canada, distributed by
Instant Pot Brands
199 Bay Street, Suite 4000
Toronto, ON M5L 1A9 Canada

In U.S., distributed by
Instant Pot Brands
3025 Highland Parkway, Suite 700
Downers Grove, IL 60515 U.S.

instantpot.com

© 2024 Instant Pot Brands
112-5679-01

Art release date
04/09/2024

INSTANT and INSTANT POT
are registered trademarks
of Instant Pot Brands