

BATTERY INSTALLATION VEHICLE (V DHTRC10219G)

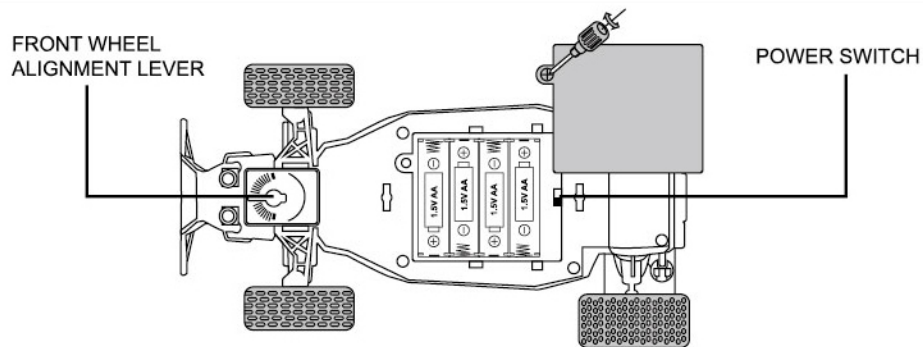

4 X 1.5V "AA" BATTERIES (NOT INCLUDED)

BATTERY INSTALLATION TRANSMITTER

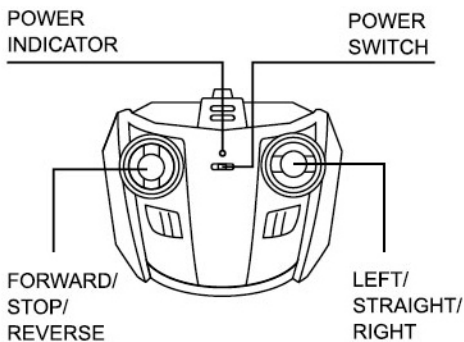

2 x 1.5V "AA" BATTERIES
(NOT INCLUDED)

⚠ WARNING:

1. Rechargeable batteries are to be removed from the toy before being charged.
2. Rechargeable batteries are only to be charged under adult supervision.
3. Non-rechargeable batteries are not to be recharged.
4. Different types of batteries or new and used batteries are not to be mixed.
5. Only batteries of the same or equivalent type as recommended are to be used.
6. Batteries are to be inserted with the correct polarity.
7. Exhausted batteries should be removed from the toy.
8. The supply terminals are not to be short-circuited.
9. Do not touch wheels or tires when they are in motion.
10. Do not collide with humans or any animals to avoid accident from occurring.

CUSTOMER INFORMATION

- Packaging should be kept since it contains important safety information.
- **WARNING!** Not suitable for children under 36 months. **CHOKING HAZARD**
- Where applicable, remove all packaging before giving this item to your child.
- Contents may vary in style, color, shape and decoration from images shown on package or in advertising.
- Please ensure to **TURN OFF** the product after play.
- Please **TAKE OUT** the batteries from product when not in use.

This device complies with Part 15 of the FCC Rules. Operation is subject to the following two conditions: (1) this device may not cause harmful interference, and (2) this device must accept any interference received, including interference that may cause undesired operation.

Note: This equipment has been tested and found to comply with the limits for a Class B digital device, pursuant to Part 15 of the FCC Rules. These limits are designed to provide reasonable protection against harmful interference in a residential installation. This equipment generates, uses and can radiate radio frequency energy and, if not installed and used in accordance with the instructions, may cause harmful interference to radio communications. However, there is no guarantee that interference will not occur in a particular installation.

If this equipment does cause harmful interference to radio or television reception, which can be determined by turning the equipment off and on, the user is encouraged to try to correct the interference by one or more of the following measures:

- Reorient or relocate the receiving antenna.
- Increase the separation between the equipment and receiver.
- Connect the equipment into an outlet on a circuit different from that to which the receiver is connected.
- Consult the dealer or an experienced radio/TV technician for help.

Caution: Changes or modifications not expressly approved by the party responsible for compliance could void the user's authority to operate the equipment.

Manufactured by:

THINAIR
BRANDS

Thin Air Brands, LLC
Parker, CO 80134

©2023 Thin Air Brands, LLC

www.ThinAirBrands.com

Designed in U.S.A
MADE IN CHINA

ITEM#RC663



23144SD