

# 无线收音麦克风

## 说明书



### 产品介绍

感谢您选择我们的产品。

本产品为智能无线麦克风，可提供专业级别的录音输出，即插即用，无需APP，多种用途，可实现网络直播、视频Vlog拍摄、节目访谈、采访录音、视频教学等场合的使用。

本产品由三部分构成，充电仓，麦克风发射端，接收端。（如下图所示，部分型号没有充电仓，以实物为准）

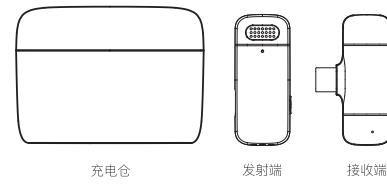

### ID图示

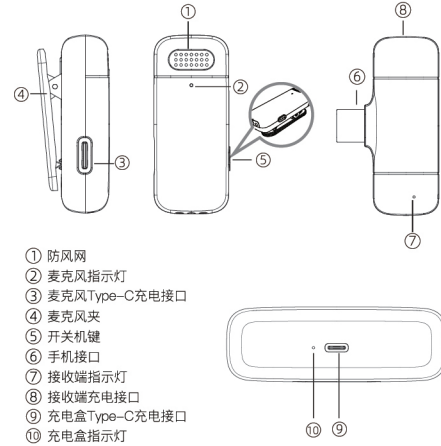

### 使用方法

第一步:把接收端的一头接入手机接口。

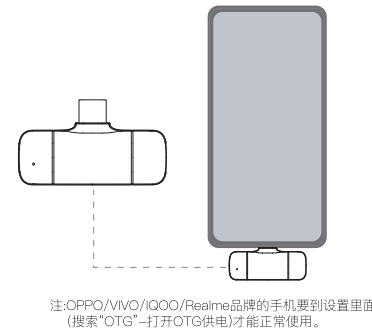

注:OPPO/VIVO/iQOO/Realme品牌的手机要到设置里面(搜索"OTG"-打开OTG供电)才能正常使用。

第二步:长按麦克风的功能键，指示灯亮绿灯，即开机成功。

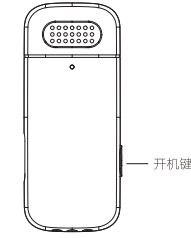

第三步:接收端红灯常亮，手机打开相机、直播视频等APP即可使用麦克风收音。

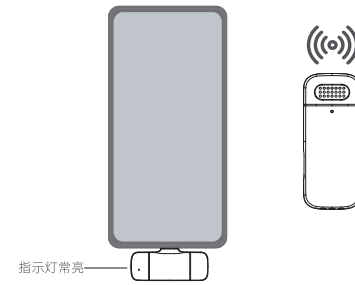

特别说明:

第⑩的使用方法如下:接收端里面没有带电池，直播时不需要充电。如果直播时，手机电量不足的情况下，直接通过接收端的接口给予手机充电。

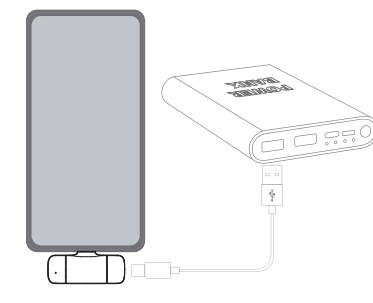

### UI功能

#### 麦克风发射端

功能/状态	按键操作	灯效
开机	长按3秒	红绿交替闪烁
关机	长按3秒	所有灯灭
未连接		红绿交替闪烁
已连接		绿灯常亮
降噪	自带AI降噪	绿灯
混响	三击按键开启或关闭混响功能	红灯闪烁一次，然后绿灯常亮
静音	双击按键开启或关闭静音功能	绿灯闪烁
充电		红灯常亮
充满电		所有灯灭
低电		红灯1秒闪烁一次

#### 接收端

功能/状态	操作	灯效
搜索配对	插入手机充电	红灯闪烁
配对成功		红灯常亮

### 包装清单

#### 包装清单内容

- (1)麦克风发射端
- (2)接收端
- (3)充电仓
- (4)Type-C充电线
- (5)用户说明书

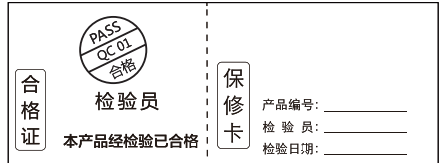

# Wireless Microphone

## User Manual



### Introduction

Thanks for choosing our product.

This product is a smart wireless microphone that provides professional-grade recording output. Plug and play, no app required. Multiple uses: It can be used in online live broadcast, video Vlog shooting, program interview, recording, video teaching and other occasions.

This product consists of three parts: charging box, microphone transmitting end and receiving end. (as shown in the figure below, some models have no charging box, subject to the real object)

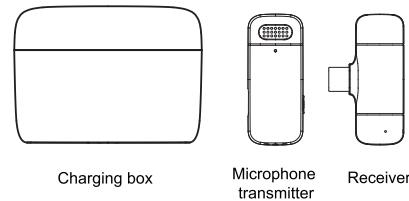

### ID Diagram

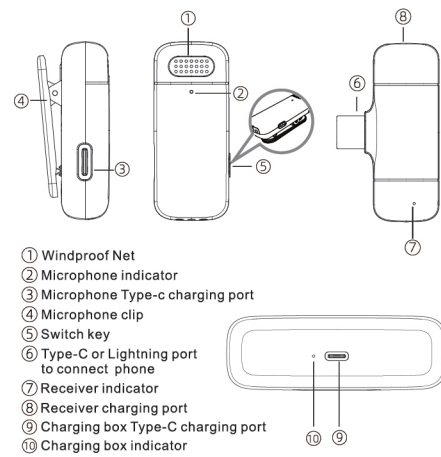

### How to use

Step 1: Connect the receiver to phone with port.

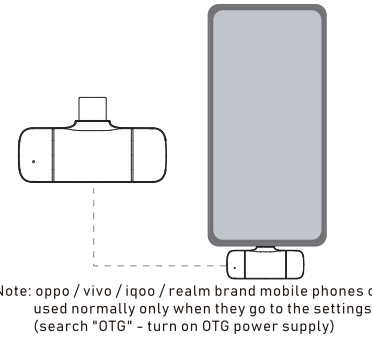

Note: oppo / vivo / iqoo / realm brand mobile phones can be used normally only when they go to the settings (search "OTG" - turn on OTG power supply)

Step 2: Press switch key of microphone, the indicator light turns green, and then power is turned on.

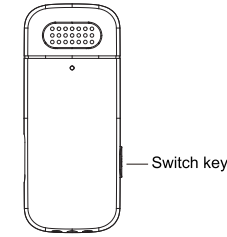

Step 3: The indicator Red light of receiver keeps always on, then open the phone camera, live App or other Apps, and then to use the microphone to receive sound.

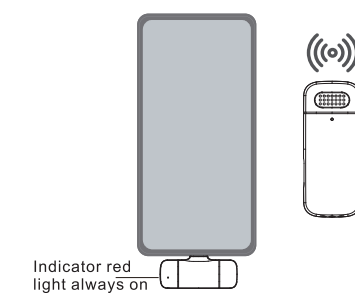

Special Note:  
For the use of port: there is no battery in receiver, and no need to recharge during live. If the phone is low power during Live, it can be recharged directly through port.

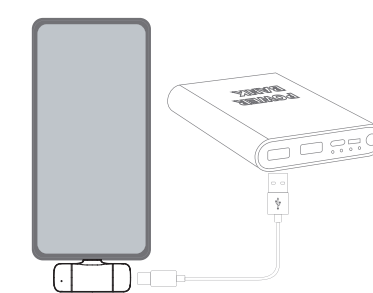

### About UI

#### Microphone Transmitter

Function	Button	LED
Power on	Button 3S startup	blinking alternately red and green
Power off	Press 3S shutdown	All the lights went out
Unconnected		blinking alternately red and green
Connected		Green light always on
noise reduction	AI noise reduction	Green light
Reverberation	Press the button three times to turn on or off the reverb function	The green and red lights blink once then the green light is always on
Silent mode	Press the twice to turn on or off the mute function	The green light blinks
Charging		Red light is always on
Fully charged		All the lights went out
Low battery		The red light blinks every 10s

#### Receiver

Function	Automatic power on after plugging in the mobile phone port	LED
Power on		The red light blinks
Power off	Automatic shutdown after unplugging	
Unconnected		The red light blinks
Connected		Red light is always on

### Packing List

- Content of packing
- (1) Microphone transmitter
- (2) Lightning receiver
- (3) Charging box
- (4) Charging cable
- (5) User manual

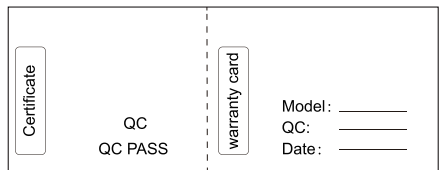

(中英文)

FCC Warning:

This equipment has been tested and found to comply with the limits for a Class B digital device, pursuant to part 15 of the FCC Rules. These limits are designed to provide reasonable protection against harmful interference in a residential installation. This equipment generates, uses and can radiate radio frequency energy and, if not installed and used in accordance with the instructions, may cause harmful interference to radio communications. However, there is no guarantee that interference will not occur in a particular installation. If this equipment does cause harmful interference to radio or television reception, which can be determined by turning the equipment off and on, the user is encouraged to try to correct the interference by one or more of the following measures:

- Reorient or relocate the receiving antenna.
- Increase the separation between the equipment and receiver.
- Connect the equipment into an outlet on a circuit different from that to which the receiver is connected.
- Consult the dealer or an experienced radio/TV technician for help.

Caution: Any changes or modifications to this device not explicitly approved by manufacturer could void your authority to operate this equipment.

This device complies with part 15 of the FCC Rules. Operation is subject to the following two conditions:

(1) This device may not cause harmful interference, and (2) this device must accept any interference received, including interference that may cause undesired operation.

This equipment complies with FCC radiation exposure limits set forth for an uncontrolled environment. This equipment should be installed and operated with minimum distance 0cm between the radiator and your body.