

SPECIFICATION FOR APPROVAL

1.MECHANICAL DIMENSION (UNIT:mm)

2.SCHEMATICS:

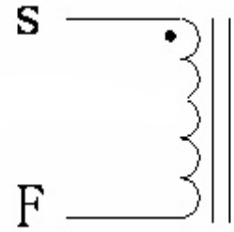
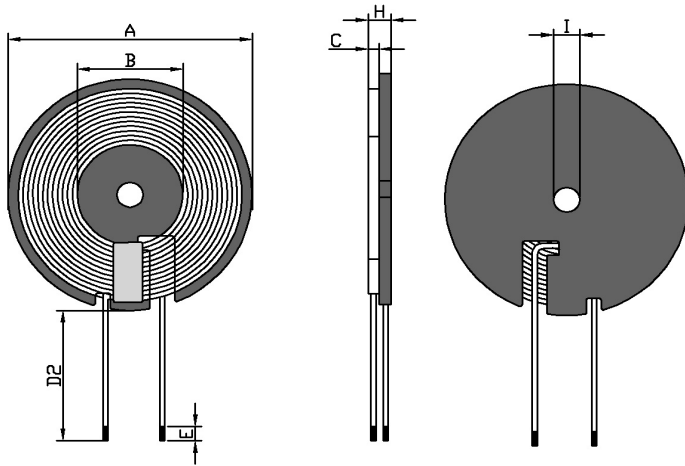

Remarks: Transparent model 1. Add adhesive, and the adhesive ear is between the two outlets 2. 8-width transparent tape 3. Coil outer diameter 43MM

A	B	C	D2	E	H				I
43.5 ± 0.05	20.5 ± 0.5	0.8 ± 0.05	5 ± 2	3 ± 2	2.2MAX	Remarks: 1. Add adhesive, and place the adhesive			

3.WINDING: 1.1 Prior

ST EP	START-FINISH	WIRE TYPE	TURNS	TAPE	REMA RK
N1	SF	Hot air line ϕ 0.08*80 2UEW	10TS (Ref)		

4.ELECTRICAL SPECIFICATION:

ITEM	L	DCR		HI-POT
TE	coil plus magnet	SF		
ST	100KHz,0.25V	AT 25 °C		
SPEC	6.5uH ± 10%	65m Ω Max		

5.BILF OF MATERIAL:

NO.	ITEM	MATERIAL SPECIFICATION	MANUFACTURER	SGS NO.
1	Hot air line 0.08*80 shares	Hot air line 0.08*80 shares	NANJINGJINNINGCO,LTD	
2	Lead-free tin bar	Lead-free tin bar	QIAODO	
3	magnetic disk	ϕ 43.5*0.8 manganese zinc hard magnetic	TAIYI CO.,LTD	
4	glue	Yellow gum 9999	LIANCHENG CO.,LTD	
5	High temperature	8mm wide high temperature tape	CUDAK CO.,LTD	
6	Adhesive	ϕ 41.8*0.1	CUDAK CO.,LTD	
7				

		PART NO	
		TITLE	43.5 slotting 0.08*80 shares 5M
DRAWN BY	CHECKED BY	APPROVED BY	
He Weihua	Wei Lihong	Wei Lihong	