

BC209 Bluetooth Module Instruction Book

1. Descriptions

1.1. Image of the module



Fig. 1: Image of BC209

1.2. Function Description

BC209 is a low-power Bluetooth 5.0 integrated module, based on the M0 core, which can support master-slave switching. It includes full function Bluetooth 5.0 . It Can develop a variety of applications based on 32-bit high-performance .

This module has rich peripherals, such as UART, SPI, IIC, GPIO, ADC, PWM, and so on. BC209 has many features, such as easy to develop, BLE connection stability.

1.3. Basic parameter

1.3.1. Bluetooth 5.0

Support 125Kbps/500Kbps/1Mbps/

Bluetooth mesh: Support SIG Mesh, Private mesh, Through transmission

1.3.2、MCU core

ARM 32-bit Cortex-M0 CPU

Highest frequency: 64MHz

Max Data SRAM: 64KB

Maximum Data Flash storage: 512KB

RX mode: 4.5mA @3.3V

TX mode: 4.3mA @3.3V 0dBm

SLEEP mode: 1uA

One broadcast for 1s in standby: 36uA

2、Hardware application

Table 2.1 Recommended operating conditions

| Rating | Min | Typ | Max | Unit | Remarks |
|-----------------------|-----|-----|-----|------|-----------|
| Operating temperature | -40 | 20 | 85 | °C | |
| VDD | 2.4 | 3.3 | 3.6 | V | |
| Operating current | - | 8 | - | mA | VDD: 3.3V |

3、Size

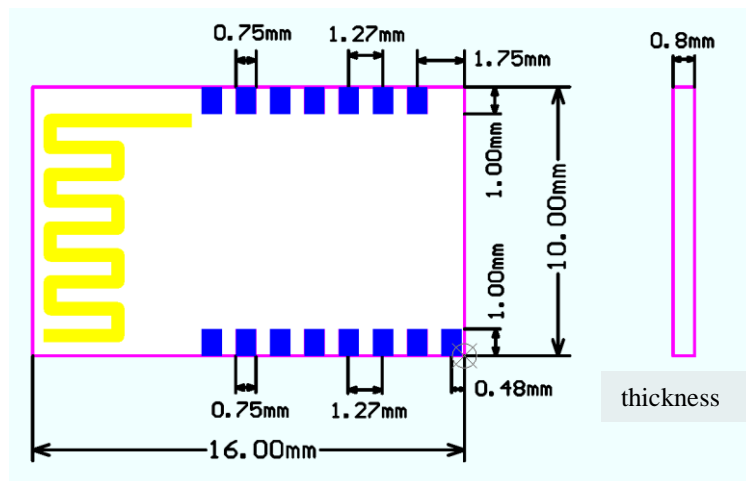

Fig 3.1 Package size chart (The overall maximum thickness of the module is 2.6mm)

Please find the corresponding business interface to provide the package information of the corresponding backplane of the module.

4、 Pin definition

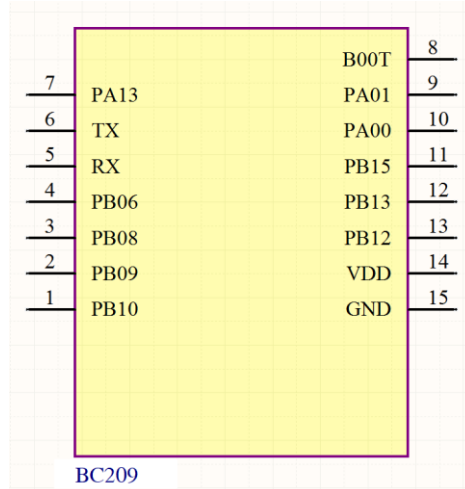

Fig 4.1 Pin Diagram

Table 4.1 Description of pin definition

| Number | Name | definition | Description |
|--------|------|------------|--|
| 1 | PB10 | PB10 | GPIO |
| 2 | PB09 | PB09 | GPIO |
| 3 | PB08 | PB08 | GPIO |
| 4 | PB06 | PB06 | GPIO |
| 5 | RX | PB01 | GPIO Serial burning RX |
| 6 | TX | PB00 | GPIO Serial burning TX |
| 7 | PA13 | PA13 | GPIO |
| 8 | BOOT | BOOT | During serial programming, the BOOT pin is pulled high (the programming point is reserved) |
| 9 | PA01 | PA01 | GPIO |
| 10 | PA00 | PA00 | GPIO Wake Up Connect to external MCU |
| 11 | PB15 | PB15 | GPIO RX Connect to the TX of external MCU |
| 12 | PB13 | PB13 | GPIO TX Connect to the RX of external MCU |
| 13 | PB12 | PB12 | GPIO |
| 14 | VDD | VDD | Positive electrode of module power |
| 15 | GND | GND | negative electrode of module power (3.3V) |

Notice: The red mark is the programming pin. When designing, it is recommended to reserve a burning point.

FCC WARNING

FCC Caution: Any changes or modifications not expressly approved by the party responsible for compliance could void the user's authority to operate this equipment. This device complies with Part 15 of the FCC Rules. Operation is subject to the following two conditions:

(1) This device may not cause harmful interference, and (2) this device must accept any interference received, including interference that may cause undesired operation. This device and its antenna(s) must not be co-located or operating in conjunction with any other antenna or transmitter.

15.105 Information to the user.

(b) For a Class B digital device or peripheral, the instructions furnished the user shall include the following or similar statement, placed in a prominent location in the text of the manual:

Note: This equipment has been tested and found to comply with the limits for a Class B digital device, pursuant to part 15 of the FCC Rules.

These limits are designed to provide reasonable protection against harmful interference in a residential installation. This equipment generates, uses and can radiate radio frequency energy and, if not installed and used in accordance with the instructions, may cause harmful interference to radio communications. However, there is no guarantee that interference will not occur in a particular installation. If this equipment does cause harmful interference to radio or television reception, which can be determined by turning the equipment off and on, the user is encouraged to try to correct the interference by one or more of the following measures:

- Reorient or relocate the receiving antenna.
- Increase the separation between the equipment and receiver.
- Connect the equipment into an outlet on a circuit different from that to which the receiver is connected.
- Consult the dealer or an experienced radio/TV technician for help.

This equipment complies with FCC radiation exposure limits set forth for an uncontrolled environment. This equipment should be installed and operated with minimum distance 20 cm between the radiator and your body.

Radiation Exposure Statement:

This equipment complies with FCC radiation exposure limits set forth for an uncontrolled environment.

This transmitter must not be co-located or operating in conjunction with any other antenna or transmitter.

The availability of some specific channels and/or operational frequency bands are country dependent and are firmware programmed at the factory to match the intended destination.

The firmware setting is not accessible by the end user.

The final end product must be labelled in a visible area with the following:

“Contains Transmitter Module BC209”

Requirement per KDB996369 D03

2.2 List of applicable FCC rules

List the FCC rules that are applicable to the modular transmitter. These are the rules that specifically establish the bands of operation, the power, spurious emissions, and operating fundamental frequencies. DO NOT list compliance to unintentional-radiator rules (Part 15 Subpart B) since that is not a condition of a module grant that is extended to a host manufacturer. See also Section 2.10 below concerning the need to notify host manufacturers that further testing is required.³

Explanation: This module meets the requirements of FCC part 15C(15.247).it specifically establish the 6dB Bandwidth,, Peak Output Power, Radiated Spurious Emission, Power Spectral Density, Restricted Band of Operation and Band Edge (Out of Band Emissions) Measurement

2.3 Summarize the specific operational use conditions

Describe use conditions that are applicable to the modular transmitter, including for example any limits on antennas, etc. For example, if point-to-point antennas are used that require reduction in power or compensation for cable loss, then this information must be in the instructions. If the use condition limitations extend to professional users, then instructions must state that this information also extends to the host manufacturer's instruction manual. In addition, certain information may also be needed, such as peak gain per frequency band and minimum gain, specifically for master devices in 5 GHz DFS bands.

Explanation: The EUT has one PCB antenna, Yes, the module contains a permanently attached antenna, The antenna gain is 2.58dBi.

2.4 Limited module procedures

If a modular transmitter is approved as a "limited module," then the module manufacturer is responsible for approving the host environment that the limited module is used with. The manufacturer of a limited module must describe, both in the filing and in the installation instructions, the alternative means that the limited module manufacturer uses to verify that the host meets the necessary requirements to satisfy the module limiting conditions.

A limited module manufacturer has the flexibility to define its alternative method to address the conditions that limit the initial approval, such as: shielding, minimum signaling amplitude, buffered modulation/data inputs, or power supply regulation. The alternative method could include that the limited module manufacturer reviews detailed test data or host designs prior to giving the host manufacturer approval.

This limited module procedure is also applicable for RF exposure evaluation when it is necessary to demonstrate compliance in a specific host. The module manufacturer must state how control of the product into which the modular transmitter will be installed will be maintained such that full compliance of the product is always ensured. For additional hosts other than the specific host originally granted with a limited

module, a Class II permissive change is required on the module grant to register the additional host as a specific host also approved with the module.

Explanation: The module is a single module.

2.5 Trace antenna designs

For a modular transmitter with trace antenna designs, see the guidance in Question 11 of KDB Publication 996369 D02 FAQ – Modules for Micro-Strip Antennas and traces. The integration information shall include for the TCB review the integration instructions for the following aspects: layout of trace design, parts list (BOM), antenna, connectors, and isolation requirements.

- a) Information that includes permitted variances (e.g., trace boundary limits, thickness, length, width, shape(s), dielectric constant, and impedance as applicable for each type of antenna);
- b) Each design shall be considered a different type (e.g., antenna length in multiple(s) of frequency, the wavelength, and antenna shape (traces in phase) can affect antenna gain and must be considered);
- c) The parameters shall be provided in a manner permitting host manufacturers to design the printed circuit (PC) board layout;
- d) Appropriate parts by manufacturer and specifications;
- e) Test procedures for design verification; and
- f) Production test procedures for ensuring compliance.

The module grantee shall provide a notice that any deviation(s) from the defined parameters of the antenna trace, as described by the instructions, require that the host product manufacturer must notify the module grantee that they wish to change the antenna trace design. In this case, a Class II permissive change application is required to be filed by the grantee, or the host manufacturer can take responsibility through the change in FCC ID (new application) procedure followed by a Class II permissive change application.

Explanation: Yes, The module with trace antenna designs, and This manual has been shown the layout of trace design,, antenna, connectors, and isolation requirements.

2.6 RF exposure considerations

It is essential for module grantees to clearly and explicitly state the RF exposure conditions that permit a host product manufacturer to use the module. Two types of instructions are required for RF exposure information: (1) to the host product manufacturer, to define the application conditions (mobile, portable – xx cm from a person's body); and (2) additional text needed for the host product manufacturer to provide to end users in their end-product manuals. If RF exposure statements and use conditions are not provided, then the host product manufacturer is required to take responsibility of the module through a change in FCC ID (new application).

Explanation: This module complies with FCC RF radiation exposure limits set forth for an uncontrolled environment, This equipment should be installed and operated with a minimum distance of 20 centimeters between the radiator and your body." This module is designed to comply with the FCC statement, FCC ID: 2BAJZ-BC209

2.7 Antennas

A list of antennas included in the application for certification must be provided in the instructions. For modular transmitters approved as limited modules, all applicable professional installer instructions must be included as part of the information to the host product manufacturer. The antenna list shall also identify the antenna types (monopole, PIFA, dipole, etc. (note that for example an "omni-directional antenna" is not considered to be a specific "antenna type")).

For situations where the host product manufacturer is responsible for an external connector, for example with an RF pin and antenna trace design, the integration instructions shall inform the installer that unique antenna connector must be used on the Part 15 authorized transmitters used in the host product. The module manufacturers shall provide a list of acceptable unique connectors.

Explanation: The EUT has one PCB antenna, Yes, the module contains a permanently attached antenna, The antenna gain is 2.58dBi.

2.8 Label and compliance information

Grantees are responsible for the continued compliance of their modules to the FCC rules. This

includes advising host product manufacturers that they need to provide a physical or e-label stating "Contains FCC ID" with their finished product. See Guidelines for Labeling and User Information for RF Devices – KDB Publication 784748.

Explanation:The host system using this module, should have label in a visible area indicated the following texts: "Contains FCC ID: 2BAJZ-BC209

2.9 Information on test modes and additional testing requirements

Additional guidance for testing host products is given in KDB Publication 996369 D04 Module Integration Guide. Test modes should take into consideration different operational conditions for a stand-alone modular transmitter in a host, as well as for multiple simultaneously transmitting modules or other transmitters in a host product.

IC statement

This device contains licence-exempt transmitter(s)/receiver(s) that comply with Innovation, Science and Economic Development Canada's licence-exempt RSS(s). Operation is subject to the following

two conditions:

(1) This device may not cause interference.

(2) This device must accept any interference, including interference that may cause undesired operation of the device.

The term "IC: " before the certification/registration number only signifies that the Industry Canada

technical specifications were met.

This product meets the applicable Industry Canada technical specifications.

Cet appareil contient des émetteurs / récepteurs exemptés de licence conformes aux RSS (RSS)

d'Innovation, Sciences et Développement économique Canada. L'exploitation est autorisée aux

deux conditions suivantes : (1) l'appareil ne doit pas produire de brouillage, et (2) l'utilisateur de

l'appareil doit accepter tout brouillage radioélectrique subi, même si le brouillage est susceptible

d'en compromettre le fonctionnement.

L'émetteur/récepteur exempt de licence contenu dans le présent appareil est conforme aux CNR

d'Innovation, Sciences et Développement économique Canada applicables aux appareils radio

exempts de licence.

L'exploitation est autorisée aux deux conditions suivantes :

1) L'appareil ne doit pas produire de brouillage;

2) L'appareil doit accepter tout brouillage radioélectrique subi, même si le brouillage est susceptible

d'en compromettre le fonctionnement.

Please notice that if the ISED certification number is not visible when the module is installed inside

another device, then the outside of the device into which the module is installed or display a label

referring to the enclosed module. This exterior label can use wording such as the following:

"Contains IC: 30177-BC209" any similar wording that expresses the same meaning may be used.

l'appareil hôte doit porter une étiquette donnant le numéro de certification du module d'Industrie

Canada, précédés des mots « Contient un module d'émission », du mot IC: 30177-BC209 ou d'une formulation similaire exprimant le même sens, comme suit

The device meets the exemption from the routine evaluation limits in section 2.5 of RSS 102 and compliance with RSS-102 RF exposure, users can obtain Canadian information on RF exposure and compliance.

Le dispositif rencontre l'exemption des limites courantes d'évaluation dans la section 2.5 de RSS

102 et la conformité

à l'exposition de RSS-102 rf, les utilisateurs peuvent obtenir l'information canadienne sur l'exposition et la

conformité rf.

This transmitter must not be co-located or operating in conjunction with any other antenna or transmitter. This equipment should be installed and operated with a minimum distance of 20 centimeters between the radiator and your body.

Cet émetteur ne doit pas être Co-placé ou fonctionnant en même temps qu'aucune autre antenne ou émetteur. Cet équipement devrait être installé et actionné avec une distance minimum

de 20 centimètres entre le radiateur et votre corps.