



FCC RADIO TEST REPORT

FCC ID : 2BAJFSN-NB01P
Equipment : Smart Node Control
Brand Name : LEOTEK
Model Name : SN-NB01 Plus
Applicant : LEOTEK Electronics Corp.
1955 Lundy Ave, San Jose, CA 95131 , San Jose, California United States 95131
Manufacturer : LEOTEK Electronics Corp.
1955 Lundy Ave, San Jose, CA 95131 , San Jose, California United States 95131
Standard : FCC 47 CFR Part 2, 22(H), 24(E), 27, Part 90(S)

The product was received on Jun. 17, 2024 and testing was performed from Jul. 30, 2024 to Aug. 27, 2024. We, Sporton International Inc. EMC & Wireless Communications Laboratory, would like to declare that the tested sample has been evaluated in accordance with the test procedures and has been in compliance with the applicable technical standards.

The test results in this report apply exclusively to the tested model / sample. Without written approval from Sporton International Inc. EMC & Wireless Communications Laboratory, the test report shall not be reproduced except in full.

Louis Wu

Approved by: Louis Wu

Sporton International Inc. EMC & Wireless Communications Laboratory

No. 52, Huaya 1st Rd., Guishan Dist., Taoyuan City 333, Taiwan (R.O.C.)



Table of Contents

History of this test report..... 3

Summary of Test Result..... 4

1 General Description 6

 1.1 Product Feature of Equipment Under Test..... 6

 1.2 Modification of EUT 6

 1.3 Testing Location 7

 1.4 Applicable Standards..... 7

2 Test Configuration of Equipment Under Test 8

 2.1 Test Mode..... 8

 2.2 Connection Diagram of Test System..... 9

 2.3 Support Unit used in test configuration and system 9

 2.4 Measurement Results Explanation Example..... 9

 2.5 Frequency List of Low/Middle/High Channels 10

3 Conducted Test Items..... 12

 3.1 Measuring Instruments 12

 3.2 Conducted Output Power and ERP/EIRP 13

 3.3 Peak-to-Average Ratio 14

 3.4 Occupied Bandwidth..... 15

 3.5 Conducted Band Edge 16

 3.6 Emission Mask..... 18

 3.7 Conducted Spurious Emission 19

 3.8 Frequency Stability 20

4 Radiated Test Items 21

 4.1 Measuring Instruments 21

 4.2 Radiated Spurious Emission Measurement 23

5 List of Measuring Equipment..... 24

6 Measurement Uncertainty 26

Appendix A. Test Results of Conducted Test

Appendix B. Test Results of Radiated Test

Appendix C. Test Setup Photographs



Summary of Test Result

Report Clause	Ref Std. Clause	Test Items	Result (PASS/FAIL)	Remark
3.2	§2.1046	Conducted Output Power	Pass	-
	§22.913 (a)(5) §90.635	Effective Radiated Power (Band 5) (Band 26)	Pass	
	§27.50 (b)(10) §27.50 (c)(10)	Effective Radiated Power (Band 12) (Band 13)		
	§24.232 (c)	Equivalent Isotropic Radiated Power (Band 2)		
	§27.50 (d)(4)	Equivalent Isotropic Radiated Power (Band 4)		
3.3	§24.232 (d) §27.50 (d)(5)	Peak-to-Average Ratio	Pass	-
3.4	§2.1049	Occupied Bandwidth	Pass	-
3.5	§2.1051 §22.917 (a) §24.238 (a) §27.53 (c)(2)(4) §27.53 (g) §27.53 (h)	Conducted Band Edge Measurement (Band 2) (Band 4) (Band 5) (Band 12) (Band 13) (Band 26)	Pass	-
3.6	§2.1051 §90.691	Emission masks (Band 26)	Pass	-
3.7	§2.1051 §22.917 (a) §24.238 (a) §27.53 (c)(2) §27.53 (g) §27.53 (h) §90.691	Conducted Spurious Emission (Band 2) (Band 4) (Band 5) (Band 12) (Band 13) (Band 26)	Pass	-
3.8	§2.1055 §22.355 §24.235 §27.54 §90.213	Frequency Stability Temperature & Voltage	Pass	-



Report Clause	Ref Std. Clause	Test Items	Result (PASS/FAIL)	Remark
4.2	§2.1053 §22.917 (a) §24.238 (a) §27.53 (c)(2) §27.53 (f) §27.53 (g) §27.53 (h) §90.691	Radiated Spurious Emission (Band 2) (Band 4) (Band 5) (Band 12) (Band 13) (Band 26)	Pass	2.06 dB under the limit at 1568.00 MHz

Conformity Assessment Condition:

1. The test results (PASS/FAIL) with all measurement uncertainty excluded are presented against the regulation limits or in accordance with the requirements stipulated by the applicant/manufacture who shall bear all the risks of non-compliance that may potentially occur if measurement uncertainty is taken into account.
2. The measurement uncertainty please refer to each test result in the section "Measurement Uncertainty".

Disclaimer:

The product specifications of the EUT presented in the test report that may affect the test assessments are declared by the manufacturer who shall take full responsibility for the authenticity.

Reviewed by: Duko Chen

Report Producer: Lucy Wu



1 General Description

1.1 Product Feature of Equipment Under Test

Product Feature	
General Specs LTE and GPS	
Antenna Type WWAN: Embedded Hoder Antenna GPS: Integrated Patch Antenna	
Sample 1	WWAN module: ME310G1-W1; Capacitor Manufacturer: Viking (blue capacitance)
Sample 3	WWAN module: ME310G1-W1; Capacitor Manufacturer: ANGA POW (green capacitance)
Antenna Gain	LTE Band 2: 1.44 dBi LTE Band 4: 1.44 dBi LTE Band 5: 1.34 dBi LTE Band 12: 1.34 dBi LTE Band 13: 1.34 dBi LTE Band 26: 1.34 dBi

Remark: The EUT's information above is declared by manufacturer. Please refer to Disclaimer in report summary.

Support band and evaluated information	
Supported band	B2, B4, B5, B12, B13, B26
Evaluated and Tested band	B2, B4, B5, B12, B13, B26

FDD band Power Class		
	SISO PC3	SISO PC2
B2	V	
B4	V	
B5	V	
B12	V	
B13	V	
B26	V	

1.2 Modification of EUT

No modifications made to the EUT during the testing.



1.3 Testing Location

Test Site	Sporton International Inc. EMC & Wireless Communications Laboratory	
Test Site Location	No.52, Huaya 1st Rd., Guishan Dist., Taoyuan City 333, Taiwan (R.O.C.) TEL: +886-3-327-3456 FAX: +886-3-328-4978	
Test Site No.	Sporton Site No.	
	TH03-HY	03CH07-HY
Test Engineer	Bryant Liu	Jesse Wang, Stan Hsieh and Ken Wu
Temperature (°C)	22.1~23.9	20.8~25.6
Relative Humidity (%)	50.1~56.9	48.2~66.5

Note: The test site complies with ANSI C63.4 2014 requirement.

FCC Designation No.: TW1190

1.4 Applicable Standards

According to the specifications of the manufacturer, the EUT must comply with the requirements of the following standards:

- ♦ ANSI C63.26-2015
- ♦ FCC 47 CFR Part 2, 22(H), 24(E), 27, Part 90(S)
- ♦ FCC KDB 971168 D01 Power Meas. License Digital Systems v03r01
- ♦ FCC KDB 412172 D01 Determining ERP and EIRP v01r01
- ♦ FCC KDB 414788 D01 Radiated Test Site v01r01.

Remark:

1. All the test items were validated and recorded in accordance with the standards without any modification during the testing.
2. This EUT has also been tested and complied with the requirements of FCC Part 15, Subpart B, recorded in a separate test report.
3. The TAF code is not including all the FCC KDB listed without accreditation.



2 Test Configuration of Equipment Under Test

2.1 Test Mode

Antenna port conducted and radiated test items listed below are performed according to KDB 971168 D01 Power Meas. License Digital Systems v03r01 with maximum output power.

For radiated measurement, the measured emission level of the EUT was maximized by rotating the EUT on a turntable, adjusting the orientation of the EUT and EUT antenna in three orthogonal axis (X: flat, Y: portrait, Z: landscape), and adjusting the measurement antenna orientation, following C63.26 exploratory test procedures and only the worst case emissions were reported in this report..

Modulation Type	Modulation
A	BPSK
B	QPSK

Test Item	Modulation Type	Subcarrier	Tone	Channel
Conducted Power	A, B	3.75 kHz	1	L, M, H
		15 kHz	1, Full	
ERP / EIRP	A, B	3.75 kHz	1	L, M, H
		15 kHz	1, Full	
PAR	A, B	15 kHz	1, Full	L, M, H
Bandwidth	B	15 kHz	Full	L, M, H
CBE, Mask (Part 90)	A, B	All	1	L, H
CSE	A, B	All	1	L, M, H
Frequency Stability	B	15 kHz	Full	M
RSE	A, B	All	1	L, M, H

Remark:

1. Evaluated all the transmitter signal and reporting worst-case configuration among all modulation types.
2. The device is investigated from 30MHz to 10 times of fundamental signal for radiated spurious emission test under different Tone@ and modulations in exploratory test. Subsequently, only the worst-case emissions are reported.
3. One representative bandwidth is selected to perform PAR and frequency stability.
4. All the radiated test cases were performed with Sample 1 and Sample 3.

2.2 Connection Diagram of Test System

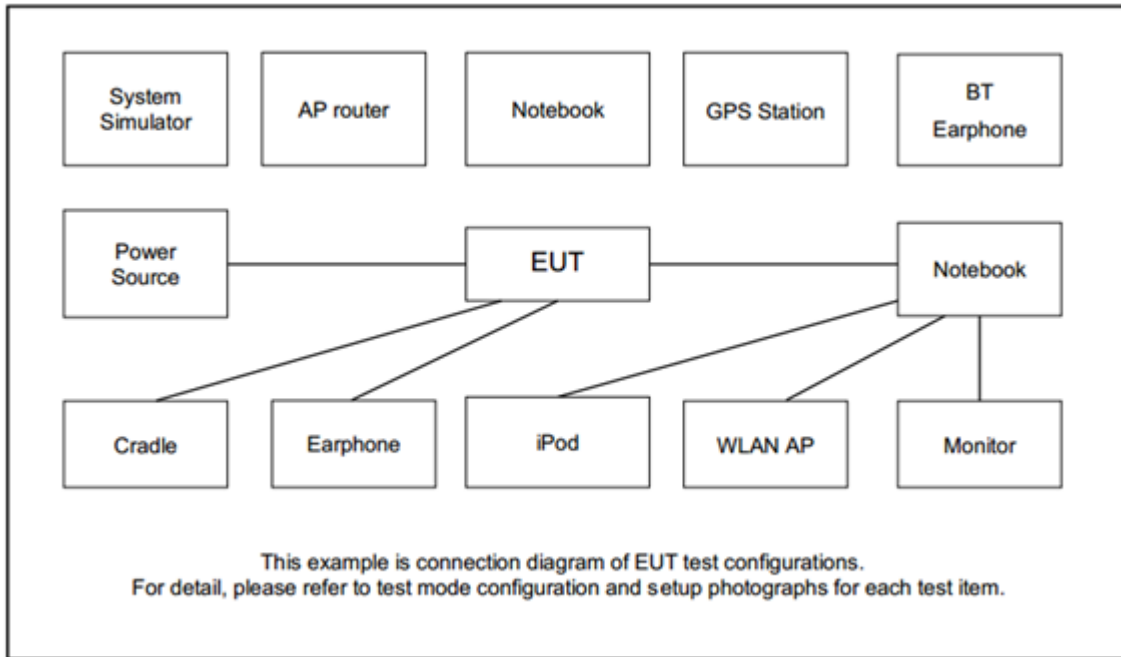

2.3 Support Unit used in test configuration and system

Item	Equipment	Brand Name	Model No.	FCC ID	Data Cable	Power Cord
1.	System Simulator	Anritsu	MT8821C	N/A	N/A	Unshielded, 1.8 m

2.4 Measurement Results Explanation Example

For all conducted test items:

The offset level is set in the spectrum analyzer to compensate the RF cable loss and attenuator factor between EUT conducted output port and spectrum analyzer. With the offset compensation, the spectrum analyzer reading level is exactly the EUT RF output level.

The spectrum analyzer offset is derived from RF cable loss and attenuator factor.

Offset = RF cable loss + attenuator factor.

Following shows an offset computation example with cable loss 4.2 dB and 10dB attenuator.

Example :

Offset(dB) = RF cable loss(dB) + attenuator factor(dB).

$$= 4.2 + 10 = 14.2 \text{ (dB)}$$



2.5 Frequency List of Low/Middle/High Channels

LTE-NB1 Band 2 Channel and Frequency List			
Channel/Frequency(MHz)	Lowest	Middle	Highest
Channel	18601	18900	19199
Frequency	1850.1	1880.0	1909.9

LTE-NB1 Band 4 Channel and Frequency List			
Channel/Frequency(MHz)	Lowest	Middle	Highest
Channel	19951	20175	20399
Frequency	1710.1	1732.5	1754.9

LTE-NB1 Band 5 Channel and Frequency List			
Channel/Frequency(MHz)	Lowest	Middle	Highest
Channel	20401	20525	20649
Frequency	824.1	836.5	848.9

LTE-NB1 Band 12 Channel and Frequency List			
Channel/Frequency(MHz)	Lowest	Middle	Highest
Channel	23011	23095	23179
Frequency	699.1	707.5	715.9

LTE-NB1 Band 13 Channel and Frequency List			
Channel/Frequency(MHz)	Lowest	Middle	Highest
Channel	23181	23230	23279
Frequency	777.1	782.0	786.9

LTE-NB1 Band 26 Channel and Frequency List (Part22H)			
Channel/Frequency(MHz)	Lowest	Middle	Highest
Channel	26791	26915	27039
Frequency	824.1	836.5	848.9



LTE-NB1 Band 26 Channel and Frequency List (Part90S)			
Channel/Frequency(MHz)	Lowest	Middle	Highest
Channel	26691	26740	26789
Frequency	814.1	819	823.9

LTE-NB1 Band 26 Channel and Frequency List (Part90S)			
Channel/Frequency(MHz)	cross-rule channels		
	Lowest	Middle	Highest
Channel	-	26790	-
Frequency	-	824	-

3 Conducted Test Items

3.1 Measuring Instruments

See list of measuring instruments of this test report.

3.1.1 Test Setup

3.1.2 Conducted Output Power

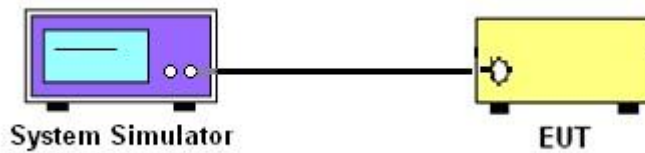

3.1.3 Peak-to-Average Ratio, Occupied Bandwidth ,Conducted Band-Edge, Emission Mask and Conducted Spurious Emission

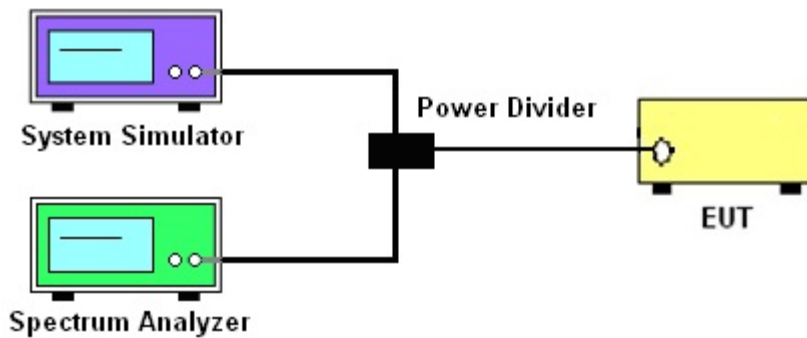

3.1.4 Frequency Stability

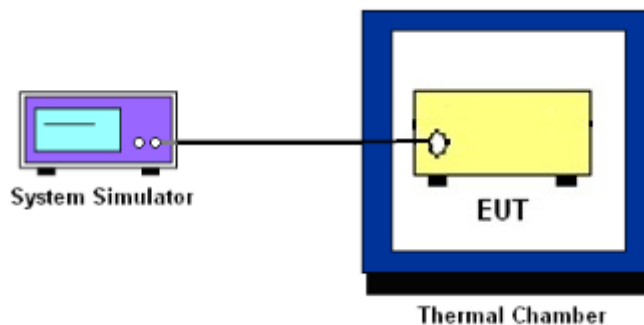

3.1.5 Test Result of Conducted Test

Please refer to Appendix A.



3.2 Conducted Output Power and ERP/EIRP

3.2.1 Description of the Conducted Output Power Measurement and ERP/EIRP Measurement

A system simulator was used to establish communication with the EUT. Its parameters were set to force the EUT transmitting at maximum output power. The measured power in the radio frequency on the transmitter output terminals shall be reported.

The ERP of mobile transmitters must not exceed 7 Watts for LTE Band 5, Band 26 (Part 22H)

The output power of mobile transmitters must not exceed 100 Watts for LTE Band 26 (Part 90S)

The ERP of mobile transmitters must not exceed 3 Watts for LTE Band 12, Band 13

The EIRP of mobile transmitters must not exceed 2 Watts for LTE Band 2

The EIRP of mobile transmitters must not exceed 1 Watts for LTE Band 4

According to KDB 412172 D01 Power Approach,

$EIRP = P_T + G_T - L_C$, $ERP = EIRP - 2.15$, where

P_T = transmitter output power in dBm

G_T = gain of the transmitting antenna in dBi

L_C = signal attenuation in the connecting cable between the transmitter and antenna in dB

3.2.2 Test Procedures

1. The transmitter output port was connected to the system simulator.
2. Set EUT at maximum power through the system simulator.
3. Select lowest, middle, and highest channels for each band and different modulation.
4. Measure and record the power level from the system simulator.



3.3 Peak-to-Average Ratio

3.3.1 Description of the PAR Measurement

Power Complementary Cumulative Distribution Function (CCDF) curves provide a means for characterizing the power peaks of a digitally modulated signal on a statistical basis. A CCDF curve depicts the probability of the peak signal amplitude exceeding the average power level. Most contemporary measurement instrumentation include the capability to produce CCDF curves for an input signal provided that the instrument's resolution bandwidth can be set wide enough to accommodate the entire input signal bandwidth. In measuring transmissions in this band using an average power technique, the peak-to-average ratio (PAR) of the transmission may not exceed 13 dB.

3.3.2 Test Procedures

The testing follows ANSI C63.26-2015 Section 5.2.6

1. The EUT was connected to spectrum and system simulator via a power divider.
2. Set the CCDF (Complementary Cumulative Distribution Function) option in spectrum analyzer.
3. The highest RF powers were measured and recorded the maximum PAPR level associated with a probability of 0.1 %.
4. Record the deviation as Peak to Average Ratio.



3.4 Occupied Bandwidth

3.4.1 Description of Occupied Bandwidth Measurement

The occupied bandwidth is the width of a frequency band such that, below the lower and above the upper frequency limits, the mean powers emitted are each equal to a specified percentage 0.5% of the total mean transmitted power.

The 26 dB emission bandwidth is defined as the frequency range between two points, one above and one below the carrier frequency, at which the spectral density of the emission is attenuated 26 dB below the maximum in-band spectral density of the modulated signal. Spectral density (power per unit bandwidth) is to be measured with a detector of resolution bandwidth equal to approximately 1.0% of the emission bandwidth.

3.4.2 Test Procedures

The testing follows ANSI C63.26-2015 Section 5.4.3 (26dB) and Section 5.4.4 (99OB)

1. The EUT was connected to spectrum analyzer and system simulator via a power divider.
2. The spectrum analyzer center frequency is set to the nominal EUT channel center frequency. The span range for the spectrum analyzer shall be between two and five times the anticipated OBW.
3. The nominal resolution bandwidth (RBW) shall be in the range of 1 to 5 % of the anticipated OBW, and the VBW shall be at least 3 times the RBW.
4. Set the detection mode to peak, and the trace mode to max hold.
5. Determine the reference value: Set the EUT to transmit a modulated signal. Allow the trace to stabilize. Set the spectrum analyzer marker to the highest level of the displayed trace.
(this is the reference value)
6. Determine the “-26 dB down amplitude” as equal to (Reference Value – X).
7. Place two markers, one at the lowest and the other at the highest frequency of the envelope of the spectral display such that each marker is at or slightly below the “-X dB down amplitude” determined in step 6. If a marker is below this “-X dB down amplitude” value it shall be placed as close as possible to this value. The OBW is the positive frequency difference between the two markers.
8. Use the 99 % power bandwidth function of the spectrum analyzer and report the measured bandwidth.



3.5 Conducted Band Edge

3.5.1 Description of Conducted Band Edge Measurement

22.917(a)

For operations in the 824 – 849 MHz band, the FCC limit is $43 + 10\log_{10}(P[\text{Watts}])$ dB below the transmitter power $P(\text{Watts})$ in a 100kHz bandwidth. However, in the 1MHz bands immediately outside and adjacent to the licensee's frequency block, a resolution bandwidth of at least one percent of the emission bandwidth of the fundamental emission of the transmitter may be employed.

24.238 (a)

For operations in the 1850-1910 and 1930-1990 MHz band, the FCC limit is $43 + 10\log_{10}(P[\text{Watts}])$ dB below the transmitter power $P(\text{Watts})$ in a 1MHz bandwidth. However, in the 1 MHz bands immediately outside and adjacent to the frequency block a resolution bandwidth of at least one percent of the emission bandwidth of the fundamental emission of the transmitter may be employed.

27.53 (c)

For operations in the 776-788 MHz band, the FCC limit is $43 + 10\log_{10}(P[\text{Watts}])$ dB below the transmitter power $P(\text{Watts})$ in a 100 kHz bandwidth. However, in the 100 kHz bands immediately outside and adjacent to the frequency block, a resolution bandwidth of at least 30 kHz may be employed. In addition, the power of any unwanted emissions in any 6.25 kHz bandwidth for all frequencies between 763-775 MHz and 793-806 MHz shall be attenuated below the transmitter power, P (dBW), by at least $65 + 10 \log_{10} p(\text{watts})$, dB, for mobile and portable equipment.

27.53 (g)

For operations in the 600MHz band and 698-746 MHz band, the FCC limit is $43 + 10\log_{10}(P[\text{Watts}])$ dB below the transmitter power $P(\text{Watts})$ in a 100 kHz bandwidth. However, in the 100 kilohertz bands immediately outside and adjacent to a licensee's frequency block, a resolution bandwidth of at least 30 kHz may be employed.

27.53 (h)

For operations in the 1710 – 1755 MHz band, 1755-1780 MHz, the FCC limit is $43 + 10\log_{10}(P[\text{Watts}])$ dB below the transmitter power $P(\text{Watts})$ in a 1 MHz bandwidth. However, in the 1MHz bands immediately outside and adjacent to the licensee's frequency block, a resolution bandwidth of at least one percent of the emission bandwidth of the fundamental emission of the transmitter may be employed.



3.5.2 Test Procedures

The testing follows FCC KDB 971168 D01 v03r01 Section 6.1.

1. The EUT was connected to spectrum analyzer and system simulator via a power divider.
2. The band edges of low and high channels for the highest RF powers were measured.
3. Set RBW \geq 1% EBW in the 1MHz band immediately outside and adjacent to the band edge.
4. Beyond the 1 MHz band from the band edge, RBW=1MHz was used.
5. Set spectrum analyzer with RMS detector.
6. The RF fundamental frequency should be excluded against the limit line in the operating frequency band.
7. Checked that all the results comply with the emission limit line.

The limit line is derived from $43 + 10\log(P)$ dB below the transmitter power P(Watts)



3.6 Emission Mask

3.6.1 Description of Emissions Mask Measurement

For LTE Band 26

Equipment used in this licensed to EA or non-EA systems shall comply with the emission mask provisions of FCC Part 90.691

(a) Out-of-band emission requirement shall apply only to the "outer" channels included in an EA license and to spectrum adjacent to interior channels used by incumbent licensees. The emission limits are as follows:

(1) For any frequency removed from the EA licensee's frequency block by up to and including 37.5 kHz, the power of any emission shall be attenuated below the transmitter power (P) in watts by at least $116 \text{ Log}_{10}(f/6.1)$ decibels or $50 + 10 \text{ Log}_{10}(P)$ decibels or 80 decibels, whichever is the lesser attenuation, where f is the frequency removed from the center of the outer channel in the block in kilohertz and where f is greater than 12.5 kHz.

(2) For any frequency removed from the EA licensee's frequency block greater than 37.5 kHz, the power of any emission shall be attenuated below the transmitter power (P) in watts by at least $43 + 10 \text{ Log}_{10}(P)$ decibels or 80 decibels, whichever is the lesser attenuation, where f is the frequency removed from the center of the outer channel in the block in kilohertz and where f is greater than 37.5 kHz.

3.6.2 Test Procedures

For LTE Band 26

1. The EUT was connected to spectrum analyzer and base station via power divider.
2. The emissions mask of low and high channels for the highest RF powers were measured.
3. Set RBW and VBW 3 times of RBW to make the measurement with the spectrum analyzer's, and according to KDB 971168 D02 Misc Rev Approve License Devices v02r01 standards, set RBW = 300 Hz to make offsets less than 37.5 kHz from a channel edge , RBW = 100 kHz to make offsets greater than 37.5 kHz, that is allowed.
4. The test results were shown below plots with a correction offset factor including cable loss, insertion loss of power divider.



3.7 Conducted Spurious Emission

3.7.1 Description of Conducted Spurious Emission Measurement

The power of any emission outside of the authorized operating frequency ranges must be lower than the transmitter power (P) by a factor of at least $43 + 10 \log (P)$ dB.

It is measured by means of a calibrated spectrum analyzer and scanned from 30 MHz up to a frequency including its 10th harmonic.

3.7.2 Test Procedures

The testing follows FCC KDB 971168 D01 v03r01 Section 6.1.

1. The EUT was connected to spectrum analyzer and system simulator via a power divider.
2. The RF output of EUT was connected to the spectrum analyzer by RF cable and attenuator. The path loss was compensated to the results for each measurement.
3. The conducted spurious emission for the whole frequency range was taken.
4. Make the measurement with the spectrum analyzer's RBW = 100 kHz if the authorized frequency band/block is at or below 1 GHz and 1 MHz if the authorized frequency band/block is above 1 GH, VBW = 3 * RBW.
5. Set spectrum analyzer with RMS detector.
6. Taking the record of maximum spurious emission.
7. The RF fundamental frequency should be excluded against the limit line in the operating frequency band.



3.8 Frequency Stability

3.8.1 Description of Frequency Stability Measurement

22.355

The frequency stability shall be measured by variation of ambient temperature and variation of primary supply voltage to ensure that the fundamental emission stays within the authorized frequency block. The frequency stability of the transmitter shall be maintained within $\pm 0.00025\%$ ($\pm 2.5\text{ppm}$) of the center frequency.

24.235 & 27.54

The frequency stability shall be sufficient to ensure that the fundamental emission stays within the authorized frequency block.

3.8.2 Test Procedures for Temperature Variation

The testing follows FCC KDB 971168 D01 v03r01 Section 9.0.

1. The EUT was set up in the thermal chamber and connected with the system simulator.
2. With power OFF, the temperature was decreased to -30°C and the EUT was stabilized before testing. Power was applied and the maximum change in frequency was recorded within one minute.
3. With power OFF, the temperature was raised in 10°C step up to 50°C . The EUT was stabilized at each step for at least half an hour. Power was applied and the maximum frequency change was recorded within one minute.

3.8.3 Test Procedures for Voltage Variation

The testing follows FCC KDB 971168 D01 v03r01 Section 9.0.

1. The EUT was placed in a temperature chamber at $20\pm 5^{\circ}\text{C}$ and connected with the system simulator.
2. The power supply voltage to the EUT was varied from 85% to 115% of the nominal value measured at the input to the EUT.
3. The variation in frequency was measured for the worst case.

4 Radiated Test Items

4.1 Measuring Instruments

See list of measuring instruments of this test report.

4.1.1 Test Setup

For radiated test below 30MHz

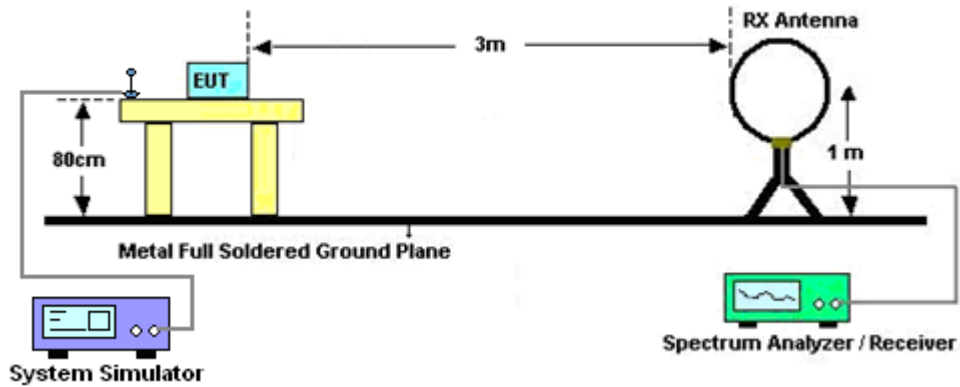

For radiated test from 30MHz to 1GHz

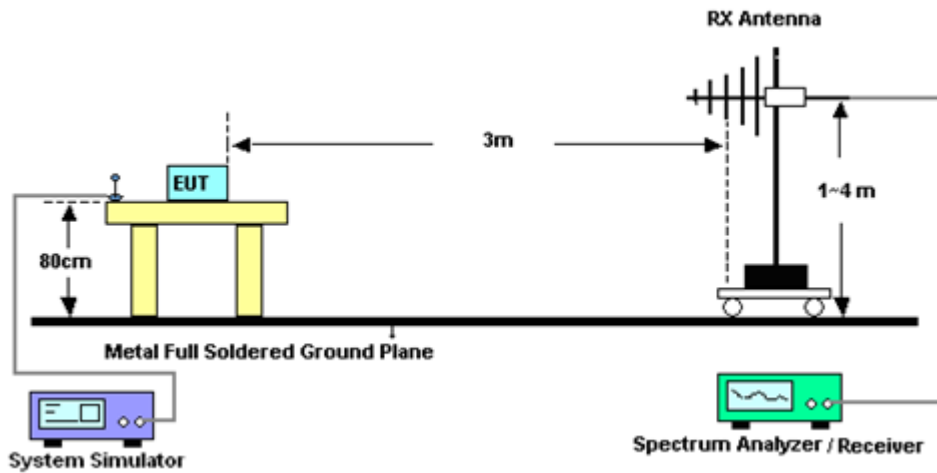

For radiated test from 1GHz to 18GHz

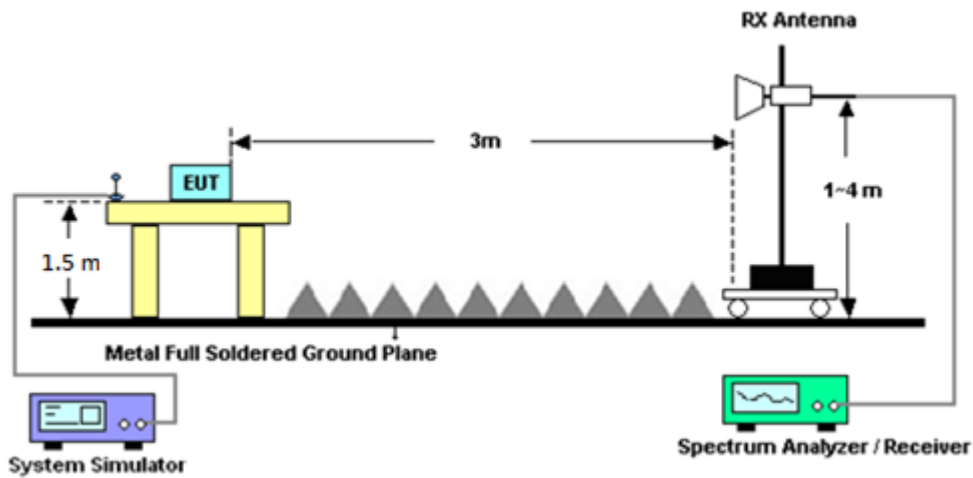

For radiated test above 18GHz

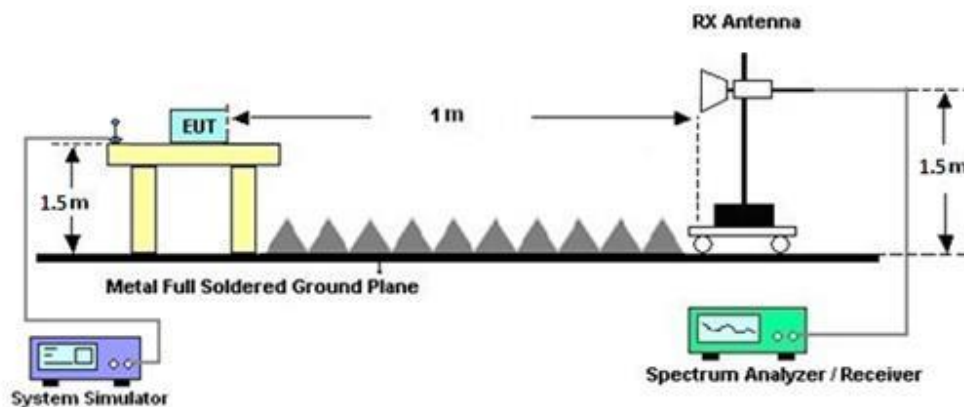

4.1.2 Test Result of Radiated Test

Please refer to Appendix B.

Note:

The low frequency, which started from 9 kHz to 30MHz, was pre-scanned and the result which was 20dB lower than the limit line was not reported.

There is adequate comparison measurement of both open-field test site and alternative test site - semi-Anechoic chamber according to 414788 D01 Radiated Test Site v01r01, and the result came out very similar.



4.2 Radiated Spurious Emission Measurement

4.2.1 Description of Radiated Spurious Emission Measurement

The radiated spurious emission was measured by substitution method according to ANSI C63.26-2015. The power of any emission outside of the authorized operating frequency ranges must be attenuated below the transmitter power (P) by a factor of at least $43 + 10 \log (P)$ dB.

For LTE Band 13

For operations in the 746-758 MHz, 775-788 MHz, and 805-806 MHz bands, emissions in the band 1559-1610 MHz shall be limited to -70 dBW/MHz equivalent isotropically radiated power (EIRP) for wideband signals, and -80 dBW EIRP for discrete emissions of less than 700 Hz bandwidth.

The spectrum is scanned from 30 MHz up to a frequency including its 10th harmonic.

4.2.2 Test Procedures

The testing follows FCC KDB 971168 D01 v03r01 Section 7 and ANSI C63.26-2015 section 5.5.4 Radiated measurement using the field strength method.

1. The EUT was placed on a turntable with 0.8 meter for frequency below 1GHz and 1.5 meter for frequency above 1GHz respectively above ground.
2. The EUT was set 3 meters from the receiving antenna, which was mounted on the antenna tower.
3. The table was rotated 360 degrees to determine the position of the highest spurious emission.
4. The height of the receiving antenna is varied between one meter and four meters to search the maximum spurious emission for both horizontal and vertical polarizations.
5. Make the measurement with the spectrum analyzer's RBW = 1MHz, VBW = 3MHz, taking the record of maximum spurious emission.
6. To convert spectrum reading E(dBuV/m) to EIRP(dBm)
$$\text{EIRP(dBm)} = \text{Level (dBuV/m)} + 20\log(d) - 104.77,$$
where d is the distance at which field strength limit is specified in the rules
7.
$$\text{Field Strength Level (dBm)} = \text{Spectrum Reading (dBm)} + \text{Antenna Factor} + \text{Cable Loss} + \text{Read Level} - \text{Preamp Factor}.$$
8.
$$\text{ERP (dBm)} = \text{EIRP (dBm)} - 2.15$$
9. The RF fundamental frequency should be excluded against the limit line in the operating frequency band.



5 List of Measuring Equipment

Instrument	Brand Name	Model No.	Serial No.	Characteristics	Calibration Date	Test Date	Due Date	Remark
Bilog Antenna	TESEQ	CBL 6111D & 00800N1D01N-06	35419 & 03	30MHz~1GHz	Apr. 22, 2024	Aug. 12, 2024~ Aug. 20, 2024	Apr. 21, 2025	Radiation (03CH07-HY)
Double Ridge Horn Antenna	ETS-Lindgren	3117	00075962	1GHz ~ 18GHz	Nov. 27, 2023	Aug. 12, 2024~ Aug. 20, 2024	Nov. 26, 2024	Radiation (03CH07-HY)
Loop Antenna	Rohde & Schwarz	HFH2-Z2	100315	9 kHz~30 MHz	Feb. 23, 2024	Aug. 12, 2024~ Aug. 20, 2024	Feb. 22, 2025	Radiation (03CH07-HY)
Preamplifier	MITEQ	AMF-7D-0010 1800-30-10P	1590075	1GHz~18GHz	Apr. 19, 2024	Aug. 12, 2024~ Aug. 20, 2024	Apr. 18, 2025	Radiation (03CH07-HY)
Preamplifier	COM-POWER	PA-103A	161241	10MHz~1GHz	Oct. 02, 2023	Aug. 12, 2024~ Aug. 20, 2024	Oct. 01, 2024	Radiation (03CH07-HY)
Preamplifier	EMEC	EM18G40G	0600789	18-40GHz	Aug. 05, 2024	Aug. 12, 2024~ Aug. 20, 2024	Aug. 04, 2025	Radiation (03CH07-HY)
Spectrum Analyzer	Agilent	N9030A	MY52350276	3Hz~44GHz	Mar. 26, 2024	Aug. 12, 2024~ Aug. 20, 2024	Mar. 25, 2025	Radiation (03CH07-HY)
RF Cable	HUBER + SUHNER	SUCOFLEX 104	MY28655/4 MY24971/4 MY15682/4	30MHz to 18GHz	Feb. 21, 2024	Aug. 12, 2024~ Aug. 20, 2024	Feb. 20, 2025	Radiation (03CH07-HY)
RF Cable	HUBER + SUHNER	SUCOFLEX 104	MY28655/4 MY24971/4	9kHz to 30MHz	Feb. 21, 2024	Aug. 12, 2024~ Aug. 20, 2024	Feb. 20, 2025	Radiation (03CH07-HY)
RF Cable	HUBER + SUHNER	SUCOFLEX 126	532078/126E	30MHz~18GHz	Sep. 15, 2023	Aug. 12, 2024~ Aug. 20, 2024	Sep. 14, 2024	Radiation (03CH07-HY)
RF Cable	HUBER + SUHNER	SUCOFLEX 102	MY2858/2	18GHz~40GHz	Feb. 21, 2024	Aug. 12, 2024~ Aug. 20, 2024	Feb. 20, 2025	Radiation (03CH07-HY)
RF Cable	HUBER + SUHNER	SUCOFLEX 102	801606/2	9KHz ~ 40GHz	Apr. 22, 2024	Aug. 12, 2024~ Aug. 20, 2024	Apr. 21, 2025	Radiation (03CH07-HY)
Controller	EMEC	EM1000	N/A	Control Ant Mast	N/A	Aug. 12, 2024~ Aug. 20, 2024	N/A	Radiation (03CH07-HY)
Controller	MF	MF-7802	N/A	Control Turn table	N/A	Aug. 12, 2024~ Aug. 20, 2024	N/A	Radiation (03CH07-HY)
Antenna Mast	EMEC	AM-BS-4500E	N/A	Boresight mast 1M~4M	N/A	Aug. 12, 2024~ Aug. 20, 2024	N/A	Radiation (03CH07-HY)
Turn Table	ChainTek	Chaintek 3000	N/A	0~360 Degree	N/A	Aug. 12, 2024~ Aug. 20, 2024	N/A	Radiation (03CH07-HY)
Software	Audix	E3	N/A	N/A	N/A	Aug. 12, 2024~ Aug. 20, 2024	N/A	Radiation (03CH07-HY)
USB Data Logger	TECPEL	TR-32	HE17XB2495	N/A	Mar. 01, 2024	Aug. 12, 2024~ Aug. 20, 2024	Feb. 28, 2025	Radiation (03CH07-HY)
Bilog Antenna	Schaffner	CBL 6112B	2892	30MHz~2GHz	Oct. 07, 2023	Aug. 12, 2024~ Aug. 20, 2024	Oct. 06, 2024	Radiation (03CH07-HY)
SHF-EHF Horn Antenna	SCHWARZBECK	BBHA 9170	BBHA9170251	18GHz~40GHz	Nov. 24, 2023	Aug. 12, 2024~ Aug. 20, 2024	Nov. 23, 2024	Radiation (03CH07-HY)



Instrument	Brand Name	Model No.	Serial No.	Characteristics	Calibration Date	Test Date	Due Date	Remark
Radio Communication Analyzer	Anritsu	MT8821C	6262025353	LTE FDD/TDD LTE-2CC DLCA/ULCA	Oct. 03, 2023	Jul. 30, 2024~ Aug. 27, 2024	Oct. 02, 2024	Conducted (TH03-HY)
Thermal Chamber	ESPEC	SH-641	92013720	-40°C ~90°C	Sep. 04, 2023	Jul. 30, 2024~ Aug. 27, 2024	Sep. 03, 2024	Conducted (TH03-HY)
AC Power Source	AC POWER	AFC-500W	F104070011	50Hz~60Hz	Sep. 22, 2023	Jul. 30, 2024~ Aug. 27, 2024	Sep. 21, 2024	Conducted (TH03-HY)
Coupler+10dB+ RFcable	Warison + WoKen + E-Instument	20dB 25W SMA Directional Coupler+ 10dB 18GHz_5W+S FL405_1.5M	#A+#1+#1+#7	1-18GHz	Jan. 02, 2024	Jul. 30, 2024~ Aug. 27, 2024	Jan. 01, 2025	Conducted (TH03-HY)
Spectrum Analyzer	Rohde & Schwarz	FSV40	101905	10Hz~40GHz	Jul. 11, 2024	Jul. 30, 2024~ Aug. 27, 2024	Jul. 10, 2025	Conducted (TH03-HY)
Software	Anritsu	Auto Test System	N/A	Conducted Test Item	N/A	Jul. 30, 2024~ Aug. 27, 2024	N/A	Conducted (TH03-HY)



6 Measurement Uncertainty

Uncertainty of Radiated Emission Measurement (30 MHz ~ 1000 MHz)

Measuring Uncertainty for a Level of Confidence of 95% ($U = 2Uc(y)$)	3.291 dB
---	----------

Uncertainty of Radiated Emission Measurement (1 GHz ~ 18 GHz)

Measuring Uncertainty for a Level of Confidence of 95% ($U = 2Uc(y)$)	2.076 dB
---	----------

Uncertainty of Radiated Emission Measurement (18 GHz ~ 40 GHz)

Measuring Uncertainty for a Level of Confidence of 95% ($U = 2Uc(y)$)	2.083 dB
---	----------



Appendix A. Test Results of Conducted Test

Conducted Output Power(Average power & ERP/EIRP)

LTE Band 2 Maximum Average Power [dBm] (GT - LC = 1.44 dB)								
Sub-carrier Spacing [kHz]	Number of Tones		Mod	Lowest	Middle	Highest	EIRP (dBm)	EIRP (W)
3.75	1	0	BPSK	9.34	20.45	9.67	21.89	0.1545
3.75	1	47		9.39	20.38	9.77		
3.75	1	0	QPSK	9.57	20.35	9.86	21.79	0.1510
3.75	1	47		9.41	20.26	9.80		
15	1	0	BPSK	9.46	20.50	10.16	21.94	0.1563
15	1	11		9.31	20.36	9.60		
15	1	0	QPSK	9.43	20.48	9.71	21.92	0.1556
15	1	11		9.33	20.38	9.59		
15	12	0		7.47	18.43	7.74		
Limit	EIRP < 2W			Result			Pass	

LTE Band 4 Maximum Average Power [dBm] (GT - LC = 1.44 dB)								
Sub-carrier Spacing [kHz]	Number of Tones		Mod	Lowest	Middle	Highest	EIRP (dBm)	EIRP (W)
3.75	1	0	BPSK	11.46	20.57	9.86	22.01	0.1589
3.75	1	47		11.50	20.56	9.82		
3.75	1	0	QPSK	11.51	20.56	9.84	22.00	0.1585
3.75	1	47		11.43	20.54	9.79		
15	1	0	BPSK	11.07	20.49	9.77	21.93	0.1560
15	1	11		11.17	20.39	9.73		
15	1	0	QPSK	11.26	20.47	9.83	21.91	0.1552
15	1	11		11.08	20.41	9.74		
15	12	0		9.07	18.43	7.81		
Limit	EIRP < 1W			Result			Pass	

LTE Band 5 Maximum Average Power [dBm] (GT - LC = 1.34 dB)								
Sub-carrier Spacing [kHz]	Number of Tones		Mod	Lowest	Middle	Highest	ERP (dBm)	ERP (W)
3.75	1	0	BPSK	10.43	20.38	11.85	19.57	0.0906
3.75	1	47		10.42	20.29	11.77		
3.75	1	0	QPSK	12.00	20.36	11.75	19.55	0.0902
3.75	1	47		11.85	20.27	11.71		
15	1	0	BPSK	11.42	20.33	10.04	19.52	0.0895
15	1	11		10.18	20.24	9.93		
15	1	0	QPSK	10.33	20.32	10.03	19.51	0.0893
15	1	11		10.21	20.25	9.94		
15	12	0		8.16	18.25	7.70		
Limit	ERP < 7W			Result			Pass	



LTE Band 12 Maximum Average Power [dBm] (GT - LC = 1.34 dB)								
Sub-carrier Spacing [kHz]	Number of Tones		Mod	Lowest	Middle	Highest	ERP (dBm)	ERP (W)
3.75	1	0	BPSK	6.38	20.38	6.40	19.57	0.0906
3.75	1	47		6.30	20.35	6.34		
3.75	1	0	QPSK	6.36	20.37	6.49	19.56	0.0904
3.75	1	47		6.28	20.32	6.38		
15	1	0	BPSK	6.12	20.25	6.31	19.44	0.0879
15	1	11		6.01	20.16	6.21		
15	1	0	QPSK	6.11	20.24	6.33	19.43	0.0877
15	1	11		6.05	20.17	6.25		
15	12	0		4.02	18.18	4.18		
Limit	ERP < 3W			Result			Pass	

LTE Band 13 Maximum Average Power [dBm] (GT - LC = 1.34 dB)								
Sub-carrier Spacing [kHz]	Number of Tones		Mod	Lowest	Middle	Highest	ERP (dBm)	ERP (W)
3.75	1	0	BPSK	6.64	20.40	6.61	19.59	0.0910
3.75	1	47		6.54	20.35	6.54		
3.75	1	0	QPSK	6.61	20.39	6.67	19.58	0.0908
3.75	1	47		6.51	20.33	6.52		
15	1	0	BPSK	6.38	20.42	5.88	19.61	0.0914
15	1	11		6.28	20.38	5.78		
15	1	0	QPSK	6.38	20.40	6.37	19.59	0.0910
15	1	11		6.42	20.33	6.29		
15	12	0		4.35	18.32	3.72		
Limit	ERP < 3W			Result			Pass	

Part22H LTE Band 26 Maximum Average Power [dBm] (GT - LC = 1.34 dB)								
Sub-carrier Spacing [kHz]	Number of Tones		Mod	Lowest	Middle	Highest	ERP (dBm)	ERP (W)
3.75	1	0	BPSK	12.00	20.53	10.31	19.72	0.0938
3.75	1	47		11.93	20.48	11.73		
3.75	1	0	QPSK	12.02	20.52	11.77	19.71	0.0935
3.75	1	47		11.94	20.45	11.69		
15	1	0	BPSK	10.53	20.67	9.96	19.86	0.0968
15	1	11		10.43	20.57	9.85		
15	1	0	QPSK	10.54	20.65	10.05	19.84	0.0964
15	1	11		10.45	20.58	9.97		
15	12	0		8.46	18.61	7.81		
Limit	ERP < 7W			Result			Pass	



Part90S LTE Band 26 Maximum Average Power [dBm] (GT - LC = 1.34 dB)								
Sub-carrier Spacing [kHz]	Number of Tones		Mod	Lowest	Middle	Highest	ERP (dBm)	ERP (W)
3.75	1	0	BPSK	5.53	20.58	5.52	19.77	0.0948
3.75	1	47		5.49	20.54	5.42		
3.75	1	0	QPSK	5.56	20.61	5.54	19.81	0.0957
3.75	1	47		5.46	20.62	5.44		
15	1	0	BPSK	5.35	20.54	5.40	19.73	0.0940
15	1	11		5.34	20.47	5.30		
15	1	0	QPSK	5.44	20.55	5.41	19.74	0.0942
15	1	11		5.32	20.51	5.33		
15	12	0		3.36	18.39	3.24		
Limit	Output Power < 100W			Result			Pass	



Part90S LTE Band 26 Straddle Maximum Average Power [dBm] (GT - LC = 1.34 dB)								
Sub-carrier Spacing [kHz]	Number of Tones		Mod	Lowest	Middle	Highest	ERP (dBm)	ERP (W)
3.75	1	0	BPSK	-	20.52	-	19.71	0.0935
3.75	1	47		-	20.48	-		
3.75	1	0	QPSK	-	20.51	-	19.70	0.0933
3.75	1	47		-	20.44	-		
15	1	0	BPSK	-	20.31	-	19.50	0.0891
15	1	11		-	20.22	-		
15	1	0	QPSK	-	20.37	-	19.56	0.0904
15	1	11		-	20.26	-		
15	12	0		-	18.27	-		
Limit	Reporting Only			Result			Pass	



LTE Band 2

Peak-to-Average Ratio

Mode	LTE Band 2 / 15kHz			
Mod.	BPSK	QPSK		Limit: 13dB
T Size	1T	1T	Full T	Result
Lowest CH	2.67	2.14	4.32	PASS
Middle CH	2.64	2.09	4.29	
Highest CH	2.67	2.14	4.32	



LTE Band 2 / 15kHz / BPSK

Lowest Channel / 1T

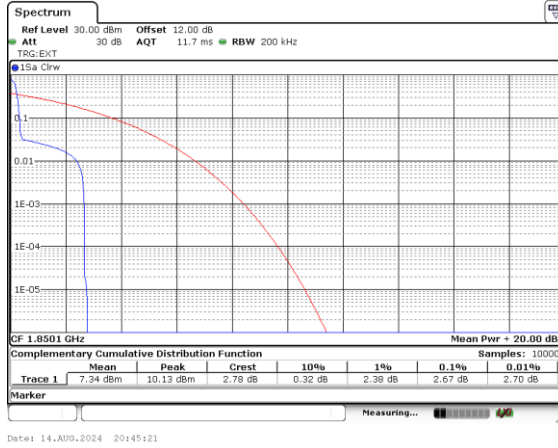

Middle Channel/ 1T

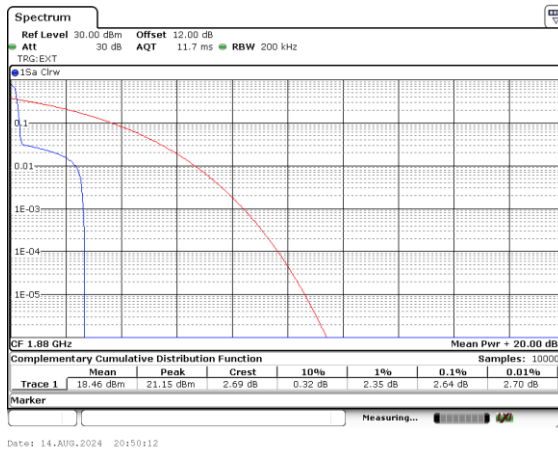

Highest Channel/ 1T

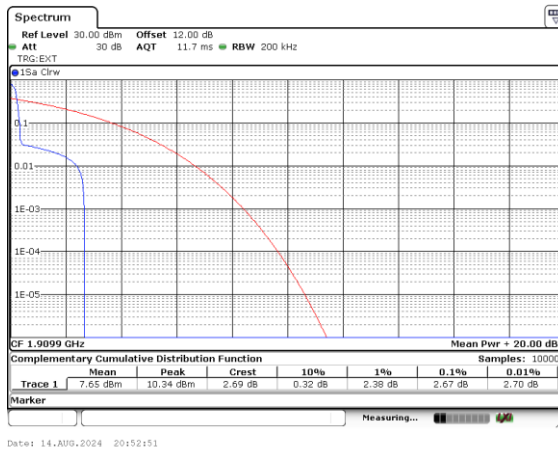



LTE Band 2 / 15k / QPSK

Lowest Channel / 1T

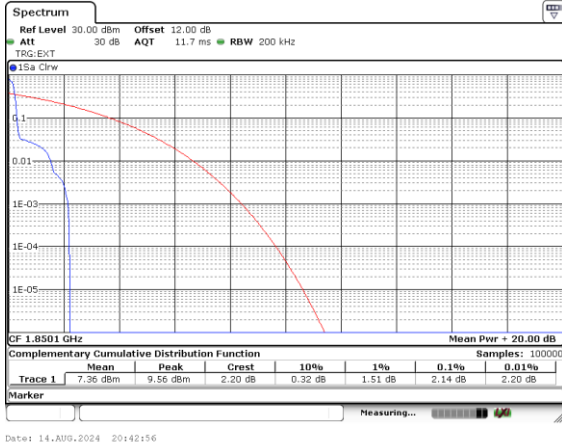

Date: 14.AUG.2024 20:42:56

Lowest Channel / Full T

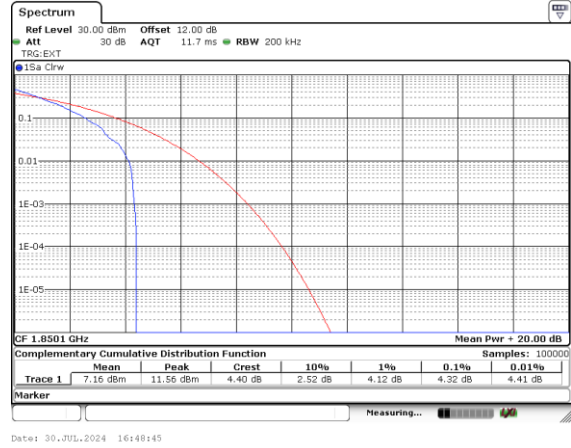

Date: 30.JUL.2024 16:48:45

Middle Channel/ 1T

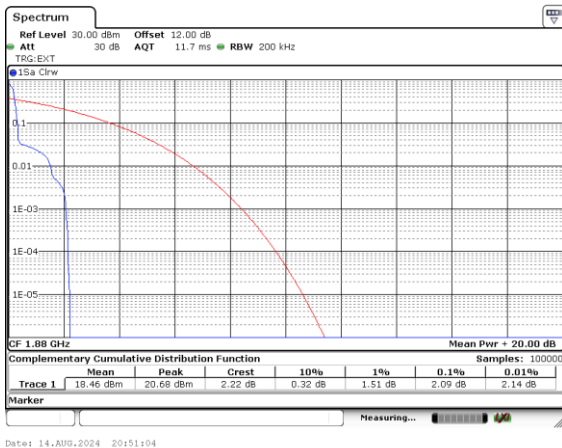

Date: 14.AUG.2024 20:51:04

Middle Channel / Full T

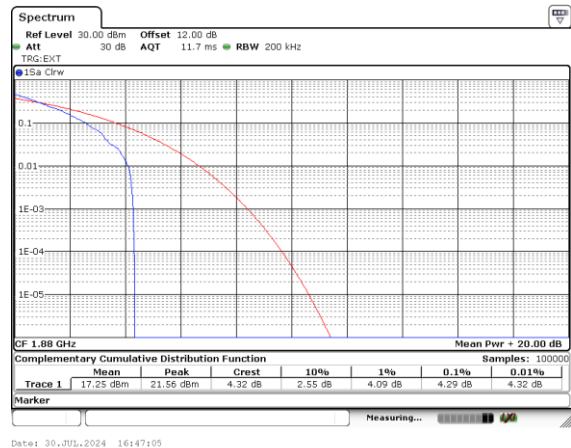

Date: 30.JUL.2024 16:47:05

Highest Channel/ 1T

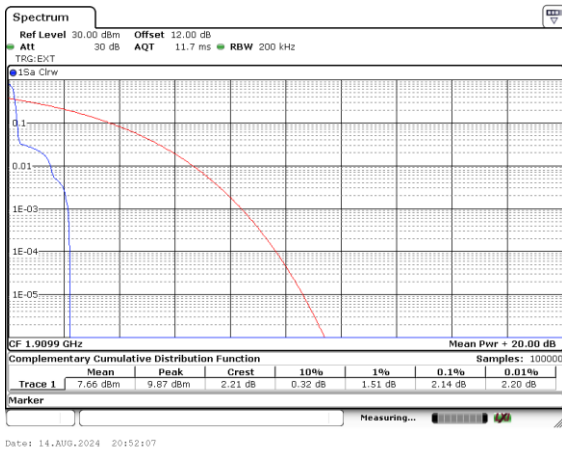

Date: 14.AUG.2024 20:52:07

Highest Channel / Full T

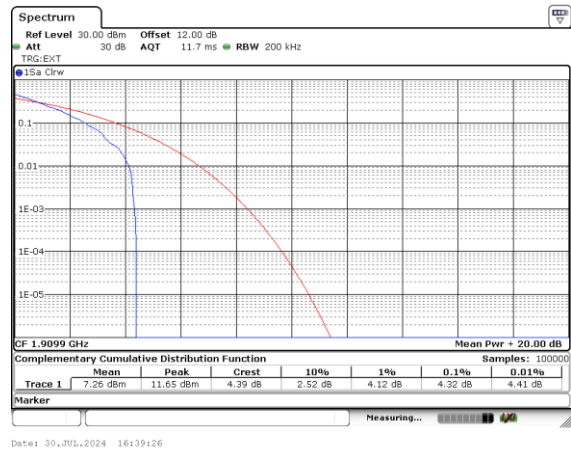

Date: 30.JUL.2024 16:39:26



26dB Bandwidth

Mode	LTE Band 2 : 26dB(kHz)
Subcarrier Spacing	15k
Mod.	QPSK
Lowest CH	220.18
Middle CH	218.18
Highest CH	216.18



LTE Band 2

Lowest Channel / 15kHz / QPSK

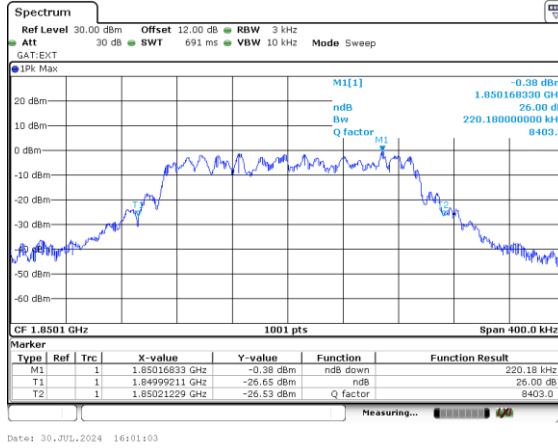

Date: 30.JUL.2024 16:01:03

Middle Channel / 15kHz / QPSK

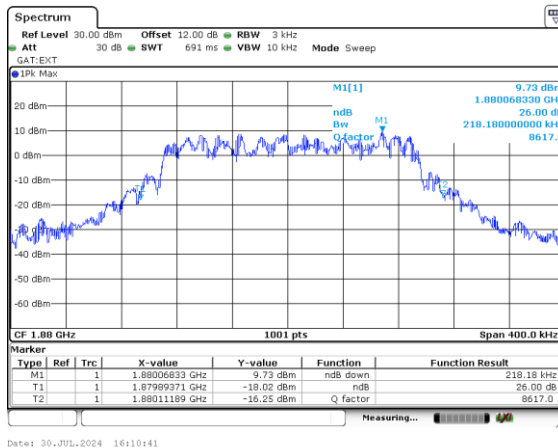

Date: 30.JUL.2024 16:10:41

Highest Channel / 15kHz / QPSK

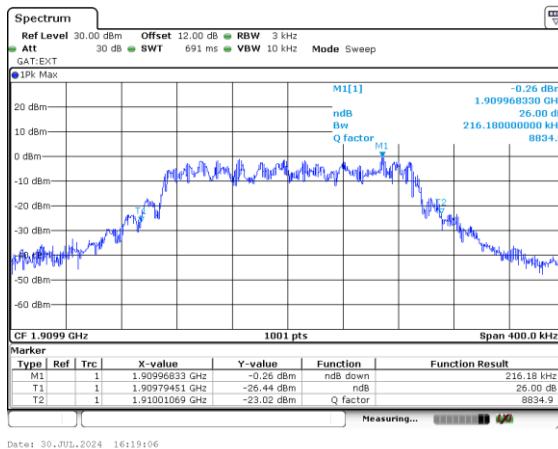

Date: 30.JUL.2024 16:19:06



Occupied Bandwidth

Mode	LTE Band 2 : OB(kHz)
Subcarrier Spacing	15k
Mod.	QPSK
Lowest CH	185.01
Middle CH	184.62
Highest CH	185.01



LTE Band 2

Lowest Channel / 15kHz / QPSK

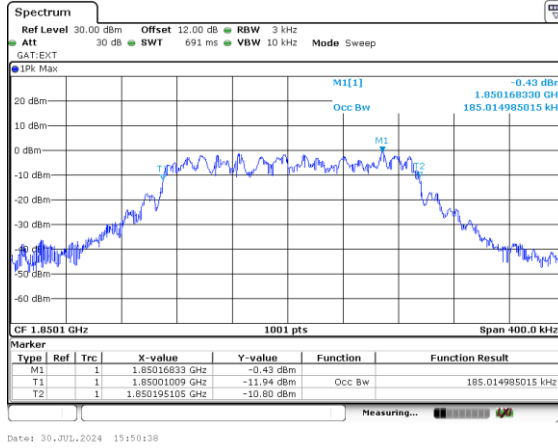

Date: 30.JUL.2024 15:50:38

Middle Channel / 15kHz / QPSK

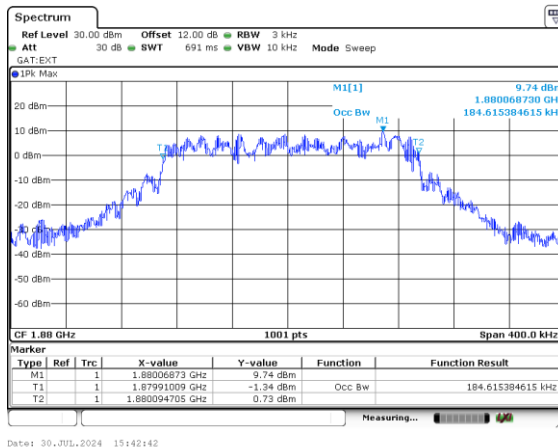

Date: 30.JUL.2024 15:42:42

Highest Channel / 15kHz / QPSK

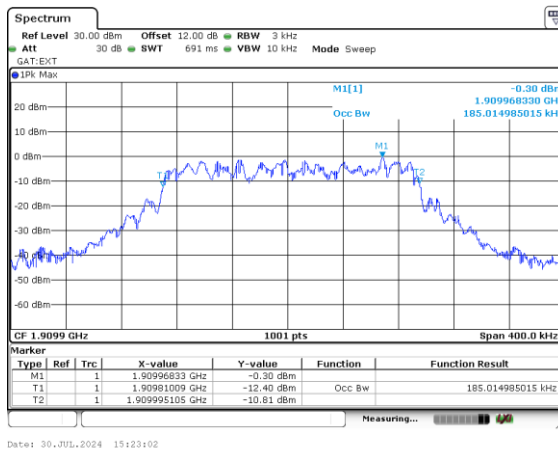

Date: 30.JUL.2024 15:12:02



Conducted Band Edge

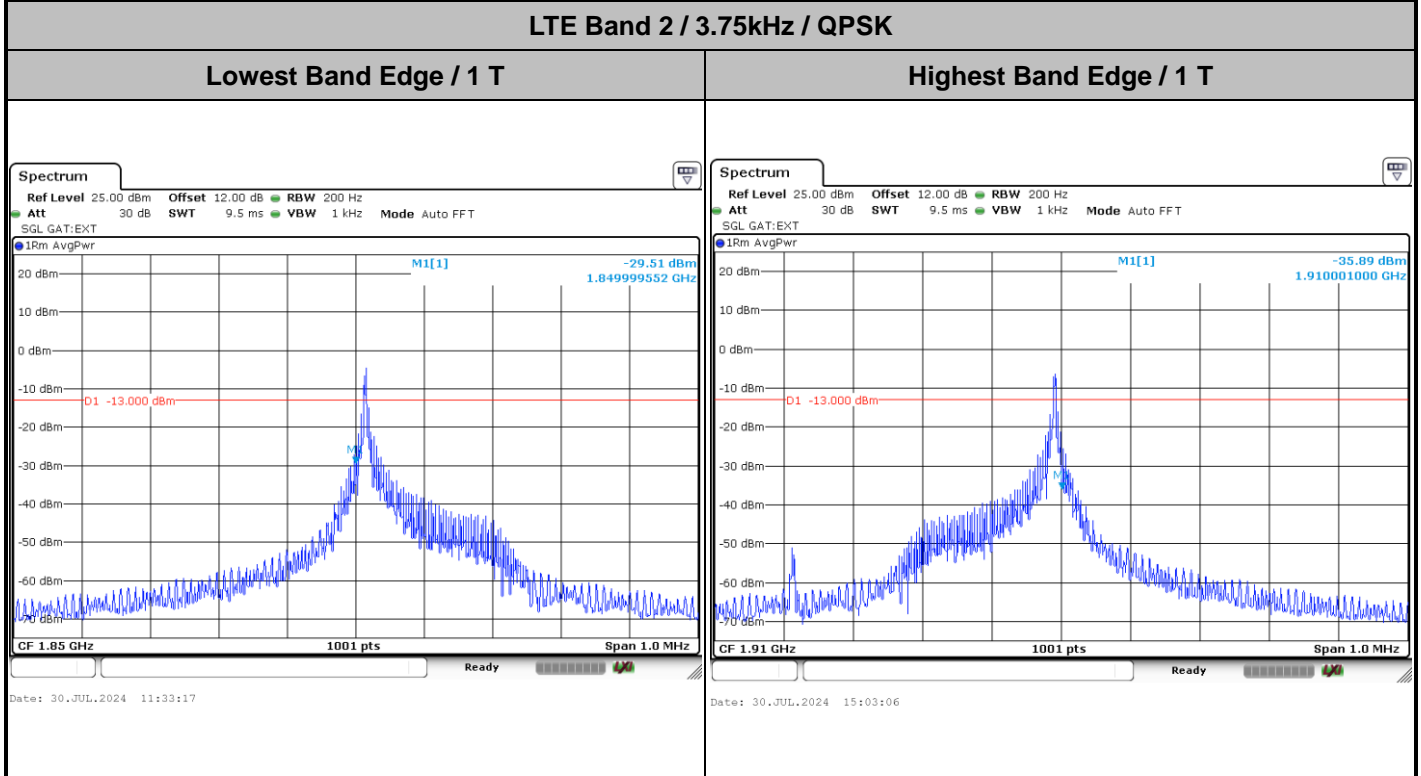
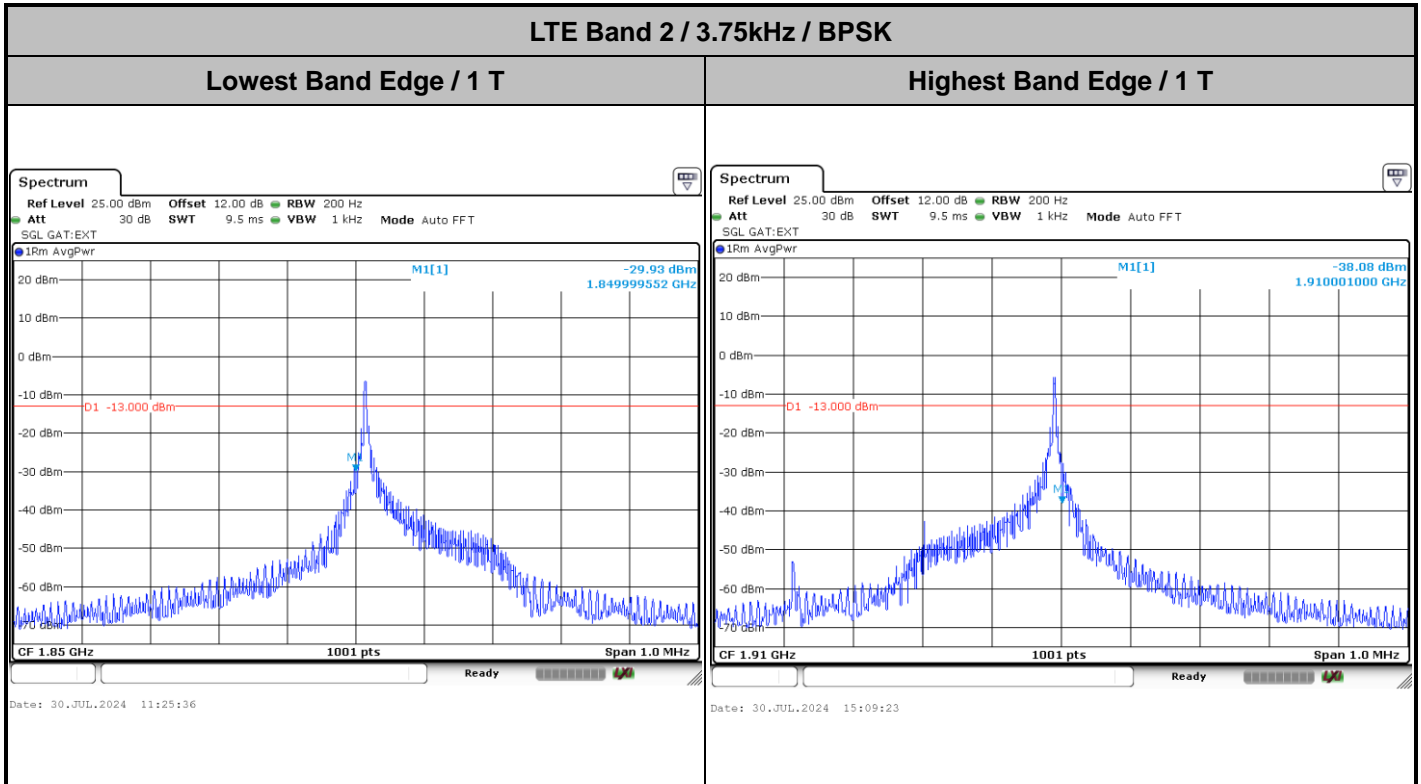



LTE Band 2 / 15kHz / BPSK

Lowest Band Edge / 1 T

Highest Band Edge / 1 T

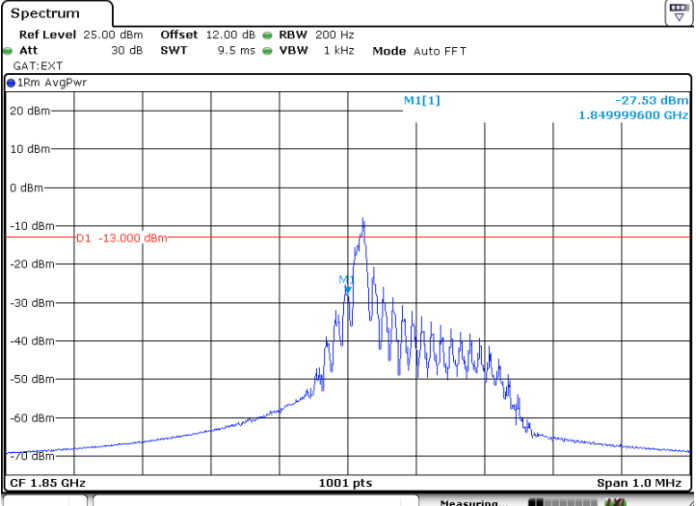

Date: 30.JUL.2024 17:28:06

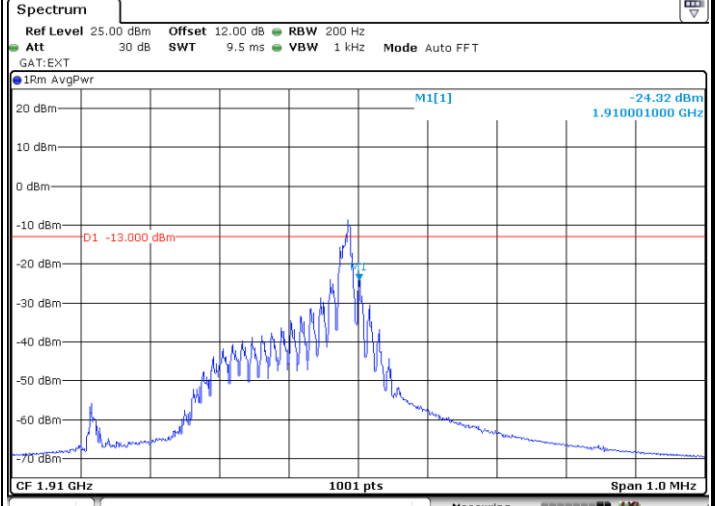

Date: 31.JUL.2024 11:57:00



LTE Band 2 / 15kHz / QPSK

Lowest Band Edge / 1 T

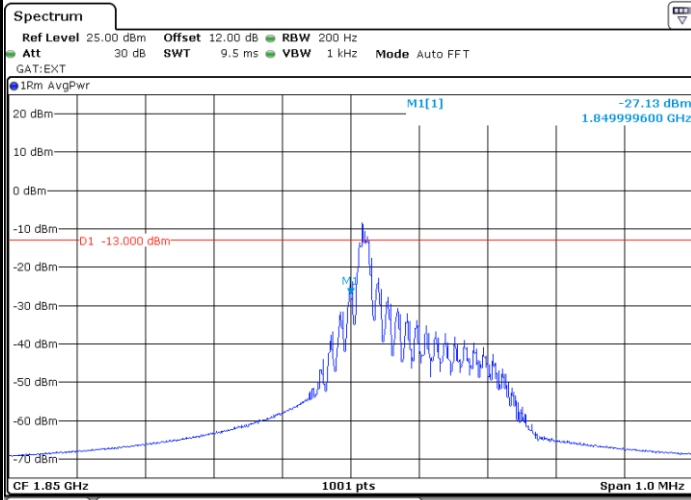

Date: 30.JUL.2024 17:08:21

Highest Band Edge / 1 T

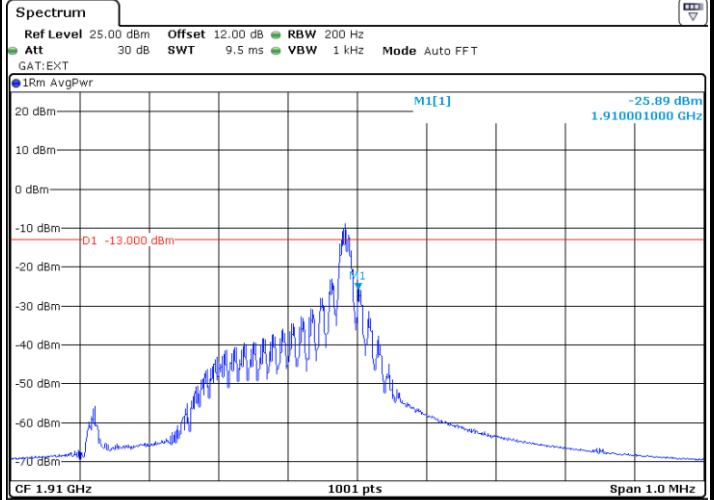

Date: 31.JUL.2024 11:55:07

Lowest Band Edge / Full T

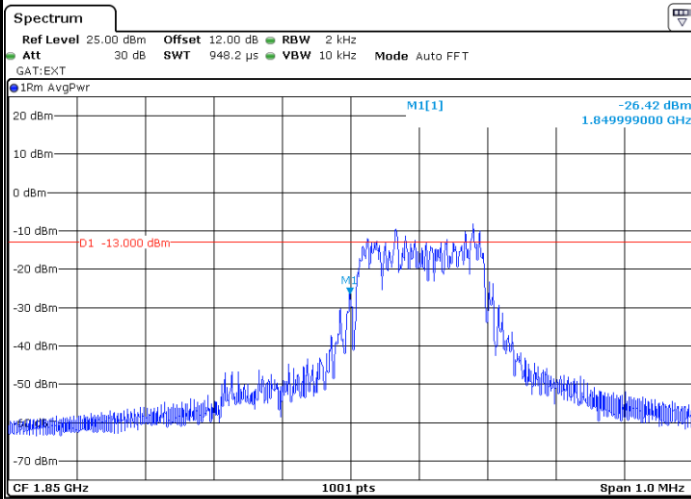

Date: 30.JUL.2024 16:50:44

Lowest Band Edge / Full T

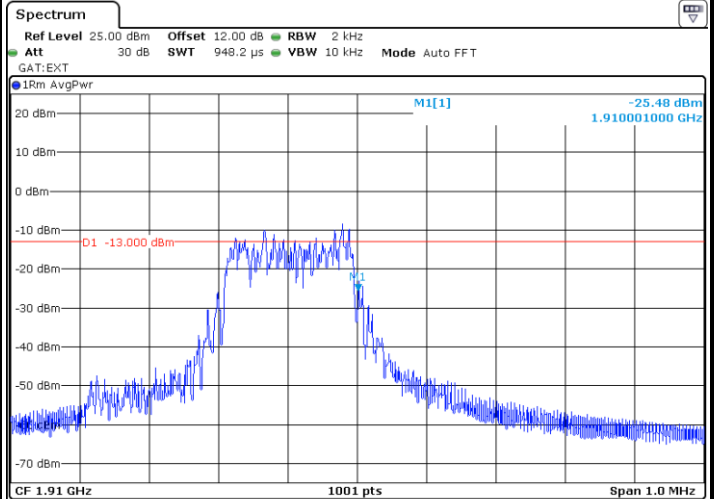

Date: 30.JUL.2024 16:21:39



Conducted Spurious Emission

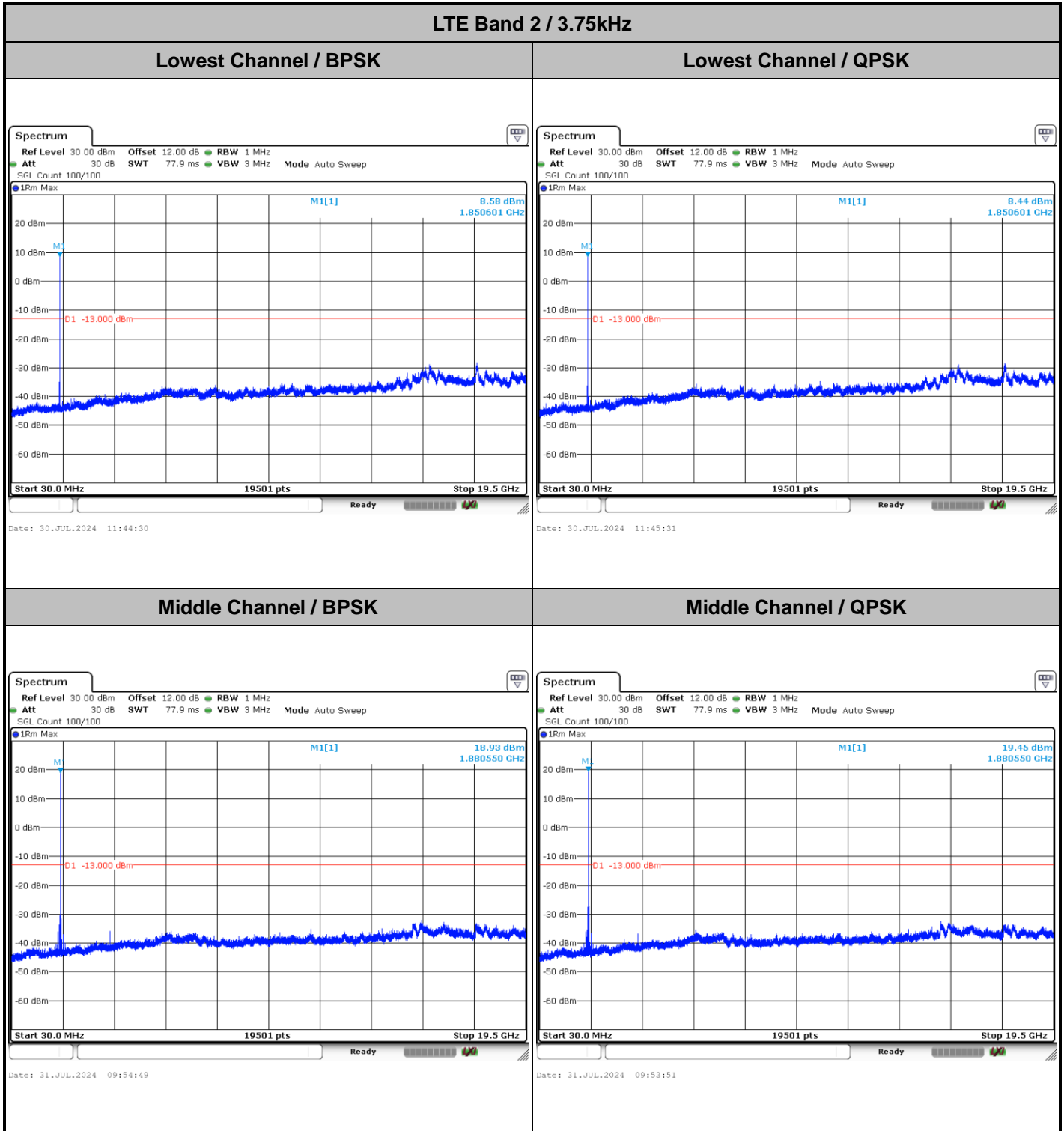

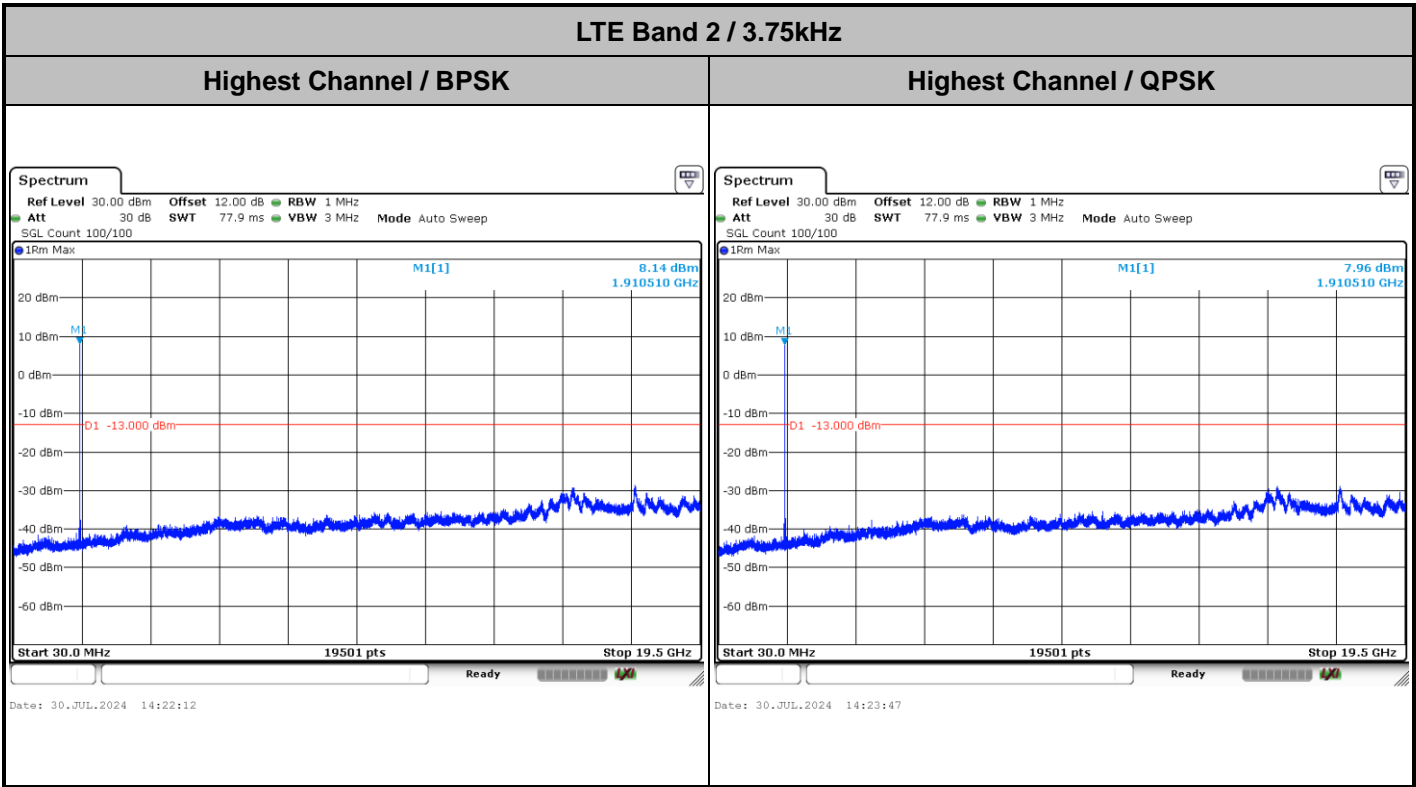



LTE Band 2 / 15kHz

Lowest Channel / BPSK

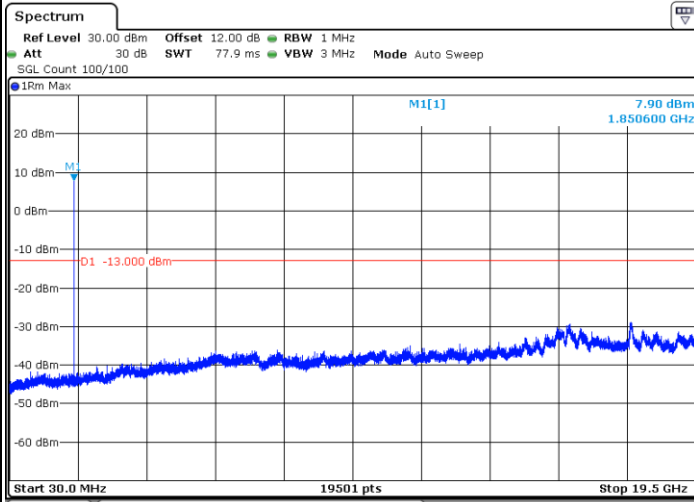

Date: 30.JUL.2024 17:30:00

Lowest Channel / QPSK

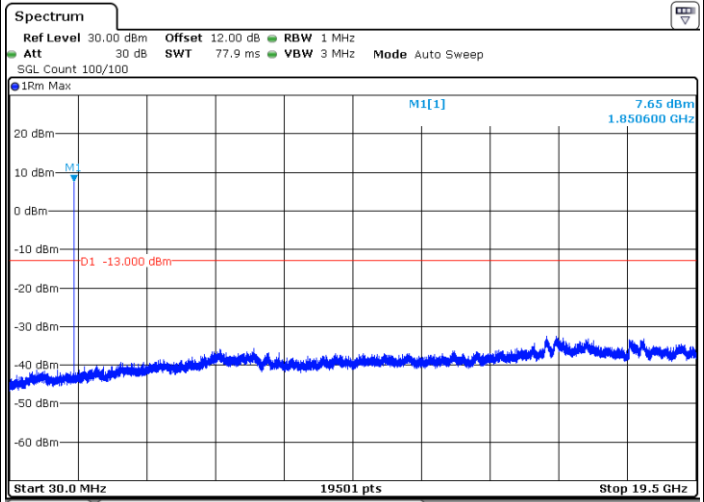

Date: 31.JUL.2024 10:03:42

Middle Channel / BPSK

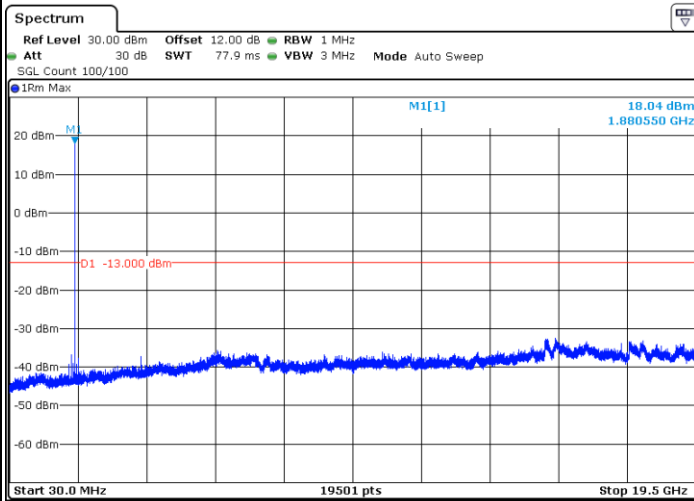

Date: 31.JUL.2024 10:48:07

Middle Channel / QPSK

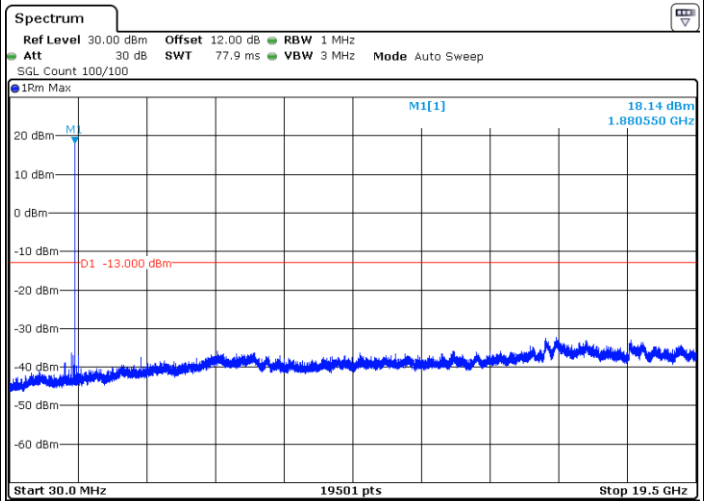

Date: 31.JUL.2024 11:16:50



LTE Band 2 / 15kHz

Highest Channel / BPSK

Highest Channel / QPSK

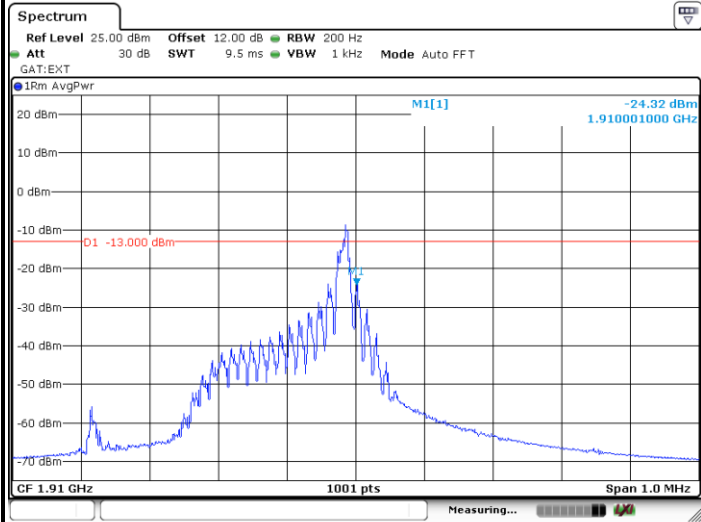

Date: 31.JUL.2024 11:57:00



Date: 31.JUL.2024 11:55:07



Frequency Stability

Test Conditions		LTE Band 2 (QPSK) / Middle Channel	Limit
Temperature (°C)	Voltage (Volt)	BW 15kHz	Note 2
		Deviation (ppm)	Result
50	Normal Voltage	0.0061	PASS
40	Normal Voltage	0.0004	
30	Normal Voltage	0.0021	
20(Ref.)	Normal Voltage	0.0000	
10	Normal Voltage	0.0026	
0	Normal Voltage	0.0010	
-10	Normal Voltage	0.0005	
-20	Normal Voltage	0.0052	
-30	Normal Voltage	0.0003	
20	Maximum Voltage	0.0048	
20	Normal Voltage	0.0000	
20	Minimum Voltage	0.0033	

Note:

1. Normal Voltage = 110 V. ; Minimum Voltage = 90 V. ; Maximum Voltage = 264 V.
2. The frequency fundamental emissions stay within the authorized frequency block.



LTE Band 4

Peak-to-Average Ratio

Mode	LTE Band 4 / 15kHz			
Mod.	BPSK	QPSK		Limit: 13dB
T Size	1T	1T	Full T	Result
Lowest CH	2.64	2.14	4.29	PASS
Middle CH	2.7	2.12	4.2	
Highest CH	2.7	2.14	4.32	



LTE Band 4 / 15kHz / BPSK

Lowest Channel / 1T

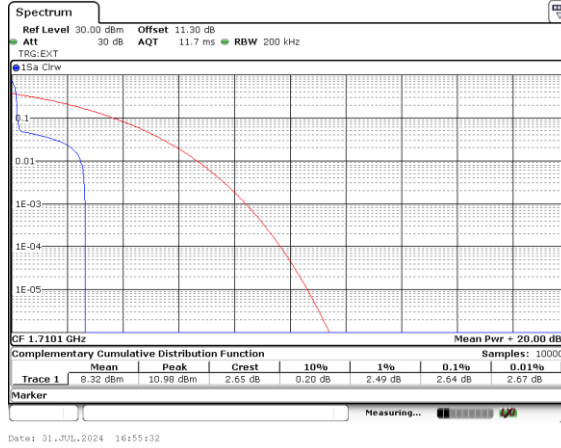

Middle Channel/ 1T

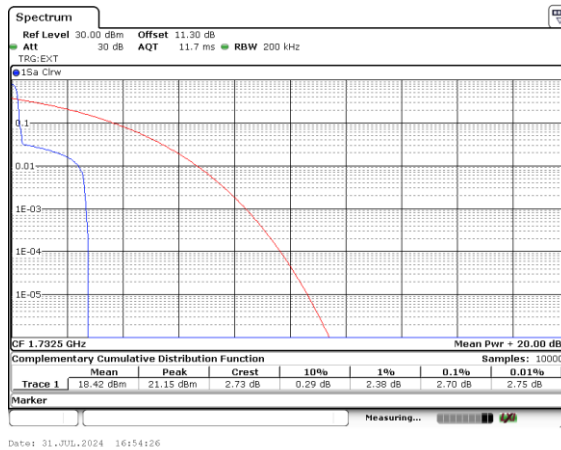

Highest Channel/ 1T

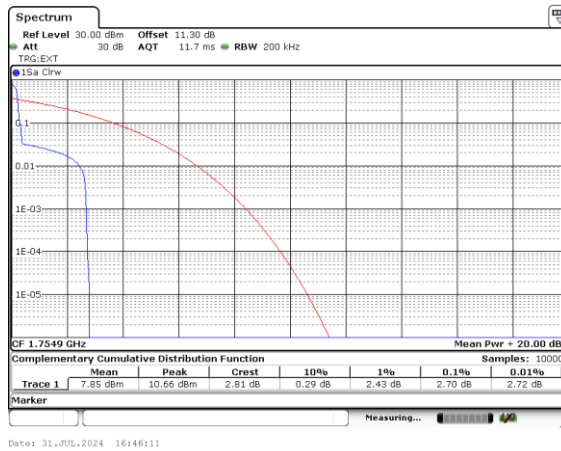



LTE Band 4 / 15kHz / QPSK

Lowest Channel / 1T

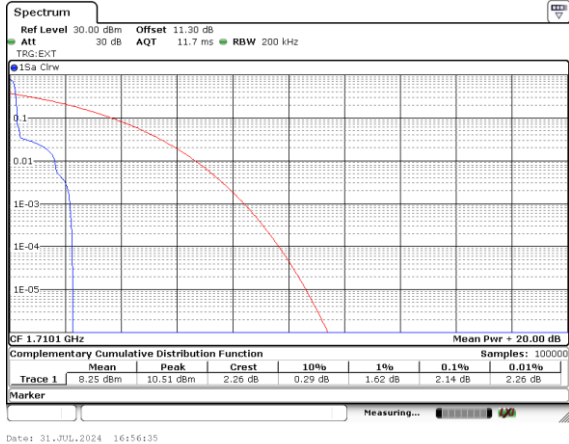

Date: 31.JUL.2024 16:56:35

Lowest Channel / Full T

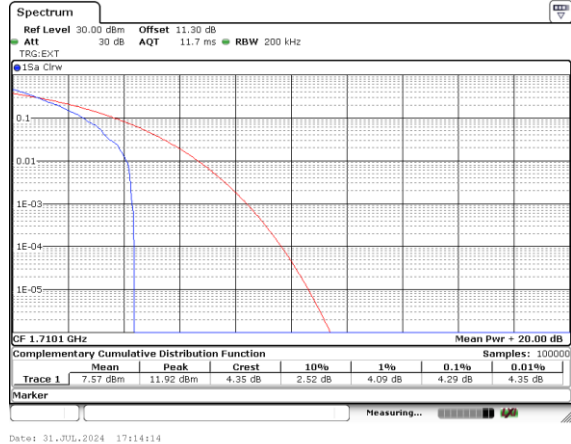

Date: 31.JUL.2024 17:14:14

Middle Channel/ 1T

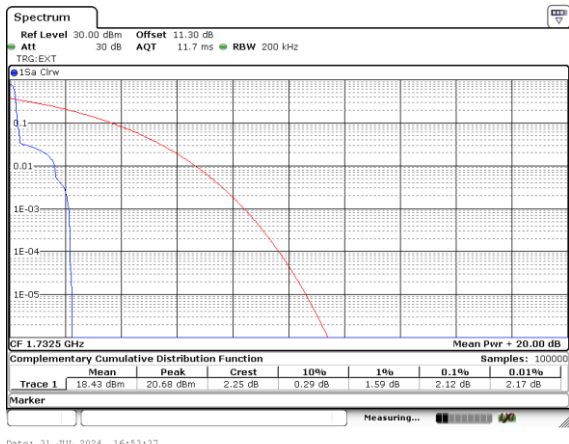

Date: 31.JUL.2024 16:53:37

Middle Channel / Full T

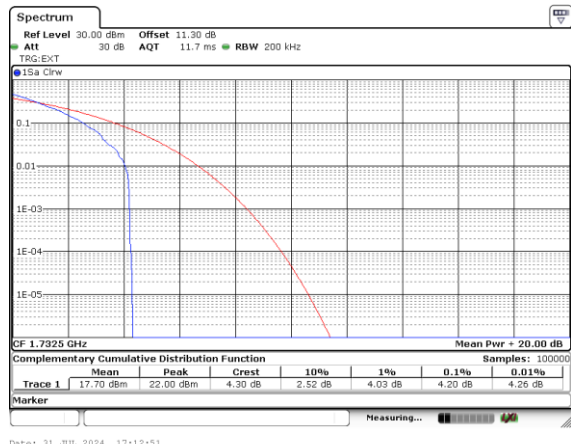

Date: 31.JUL.2024 17:12:51

Highest Channel/ 1T

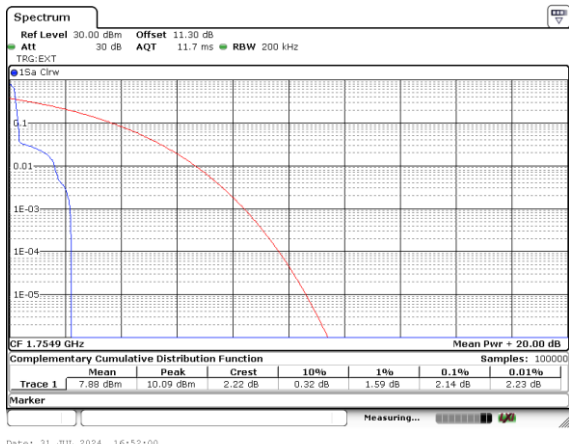

Date: 31.JUL.2024 16:52:00

Highest Channel / Full T

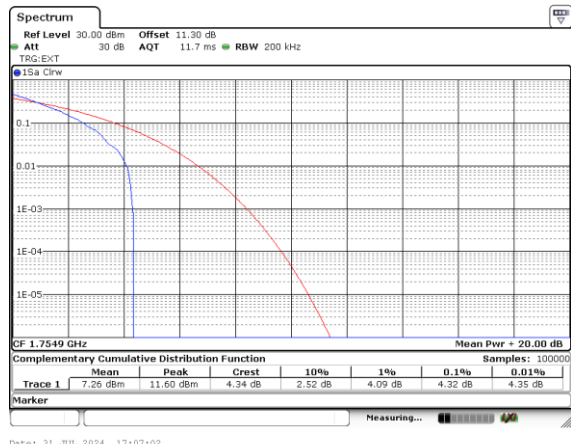

Date: 31.JUL.2024 17:07:02



26dB Bandwidth

Mode	LTE Band 4 : 26dB(kHz)
Subcarrier Spacing	15k
Mod.	QPSK
Lowest CH	205.39
Middle CH	205
Highest CH	219.38



LTE Band 4

Lowest Channel / 15kHz / QPSK

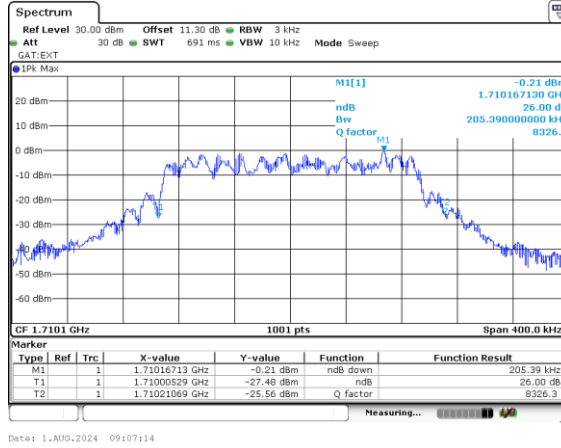

Date: 1.AUG.2024 09:07:14

Middle Channel / 15kHz / QPSK

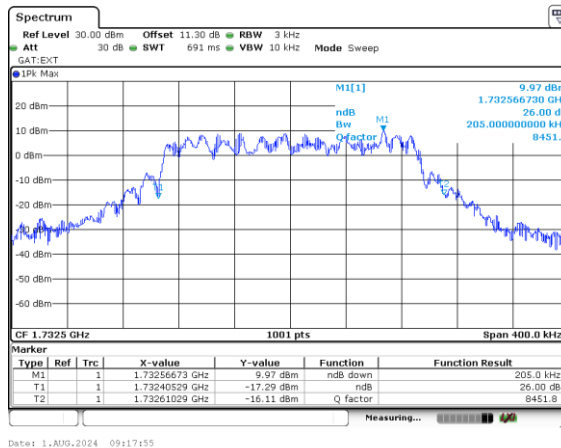

Date: 1.AUG.2024 09:17:55

Highest Channel / 15kHz / QPSK

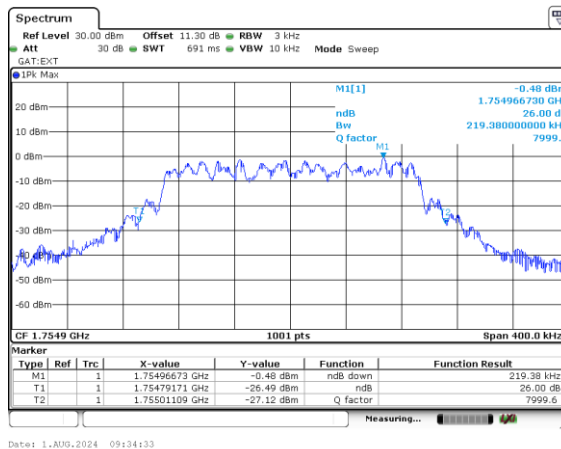

Date: 1.AUG.2024 09:34:33



Occupied Bandwidth

Mode	LTE Band 4 : OB(kHz)
Subcarrier Spacing	15k
Mod.	QPSK
Lowest CH	185.01
Middle CH	184.62
Highest CH	184.62



LTE Band 4

Lowest Channel / 15kHz / QPSK

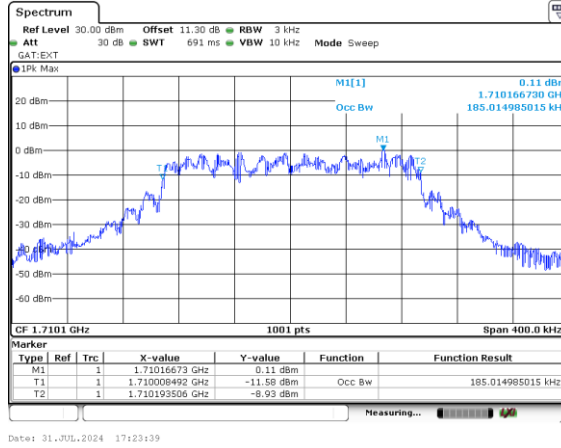

Date: 31.JUL.2024 17:23:39

Middle Channel / 15kHz / QPSK

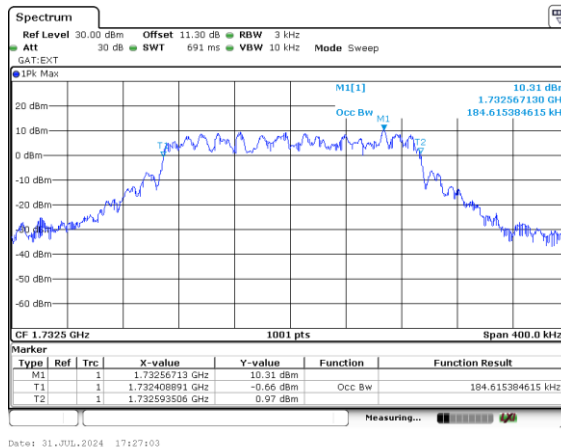

Date: 31.JUL.2024 17:27:03

Highest Channel / 15kHz / QPSK

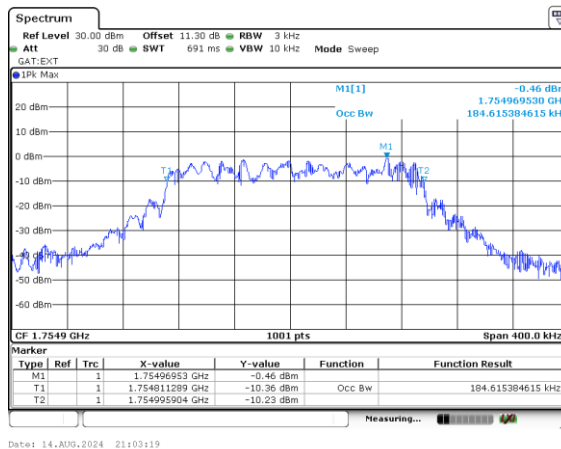

Date: 14.AUG.2024 21:03:19



Conducted Band Edge

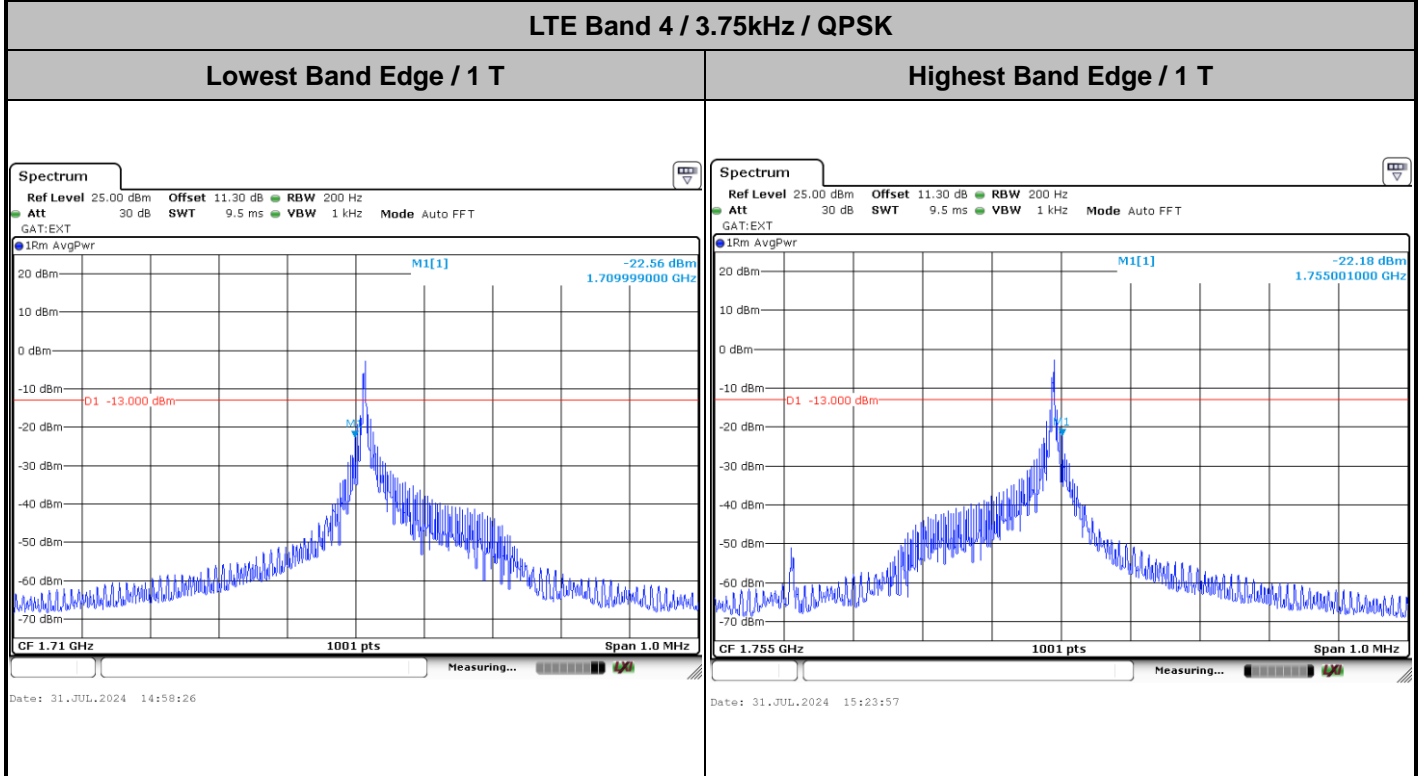
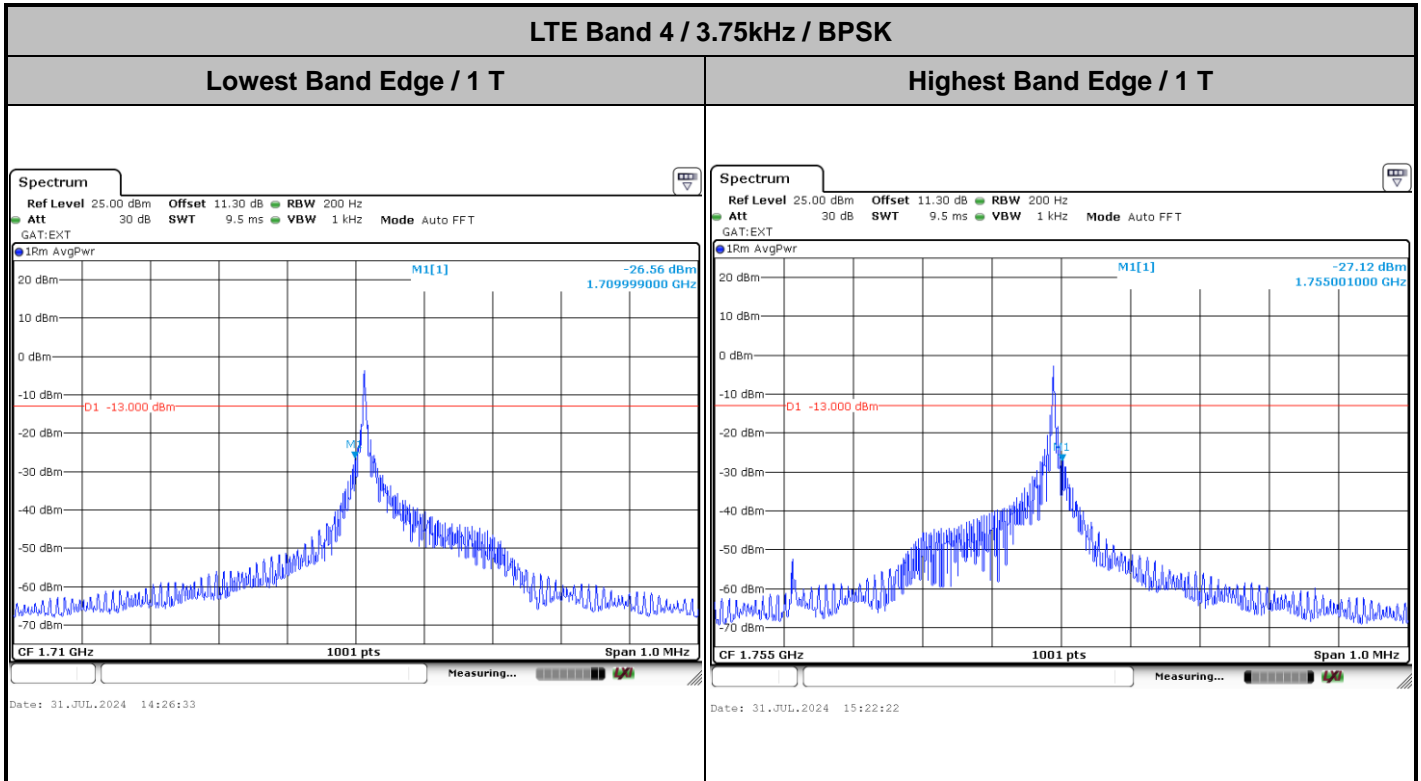



LTE Band 4 / 15kHz / BPSK

Lowest Band Edge / 1 T

Highest Band Edge / 1 T

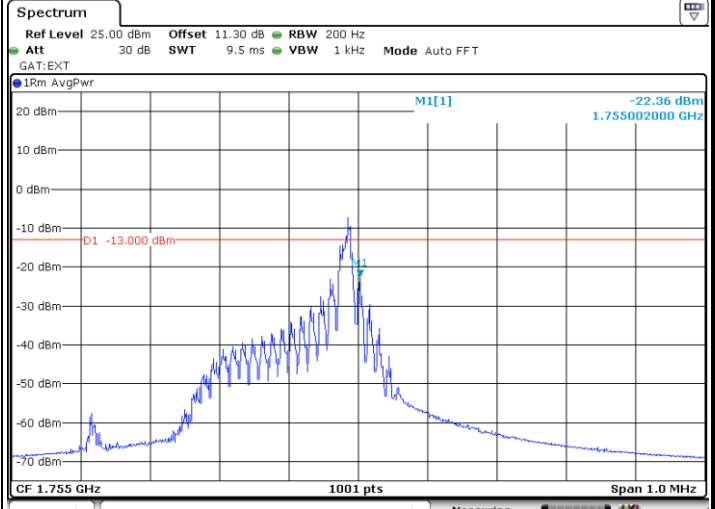
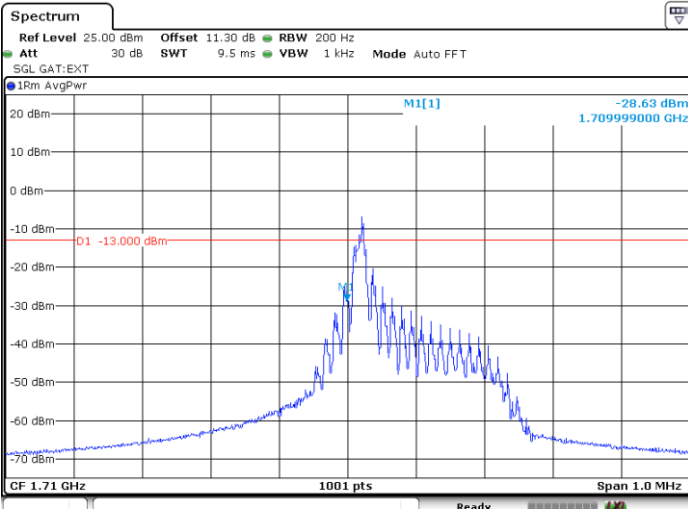

Date: 31.JUL.2024 15:45:31

Date: 31.JUL.2024 16:20:45



LTE Band 4 / 15kHz / QPSK

Lowest Band Edge / 1 T

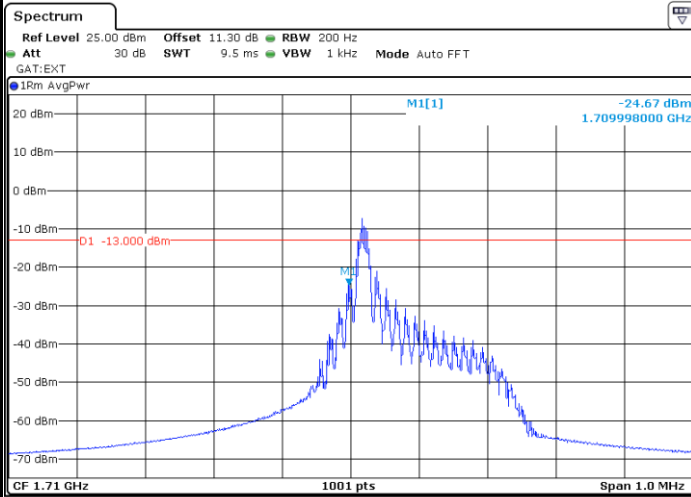

Date: 31.JUL.2024 15:47:44

Highest Band Edge / 1 T

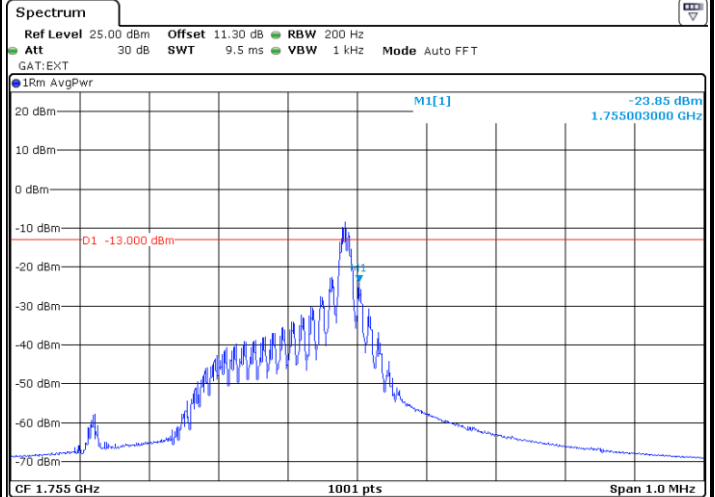

Date: 31.JUL.2024 16:22:24

Lowest Band Edge / Full T

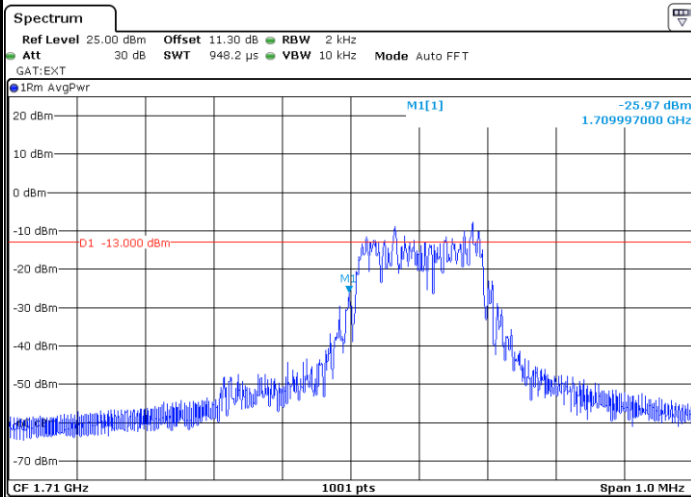

Date: 31.JUL.2024 17:03:05

Highest Band Edge / Full T

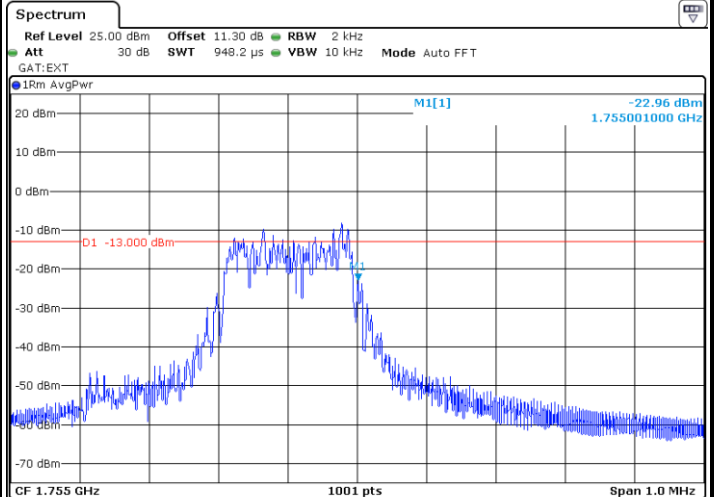

Date: 31.JUL.2024 17:05:53



Conducted Spurious Emission

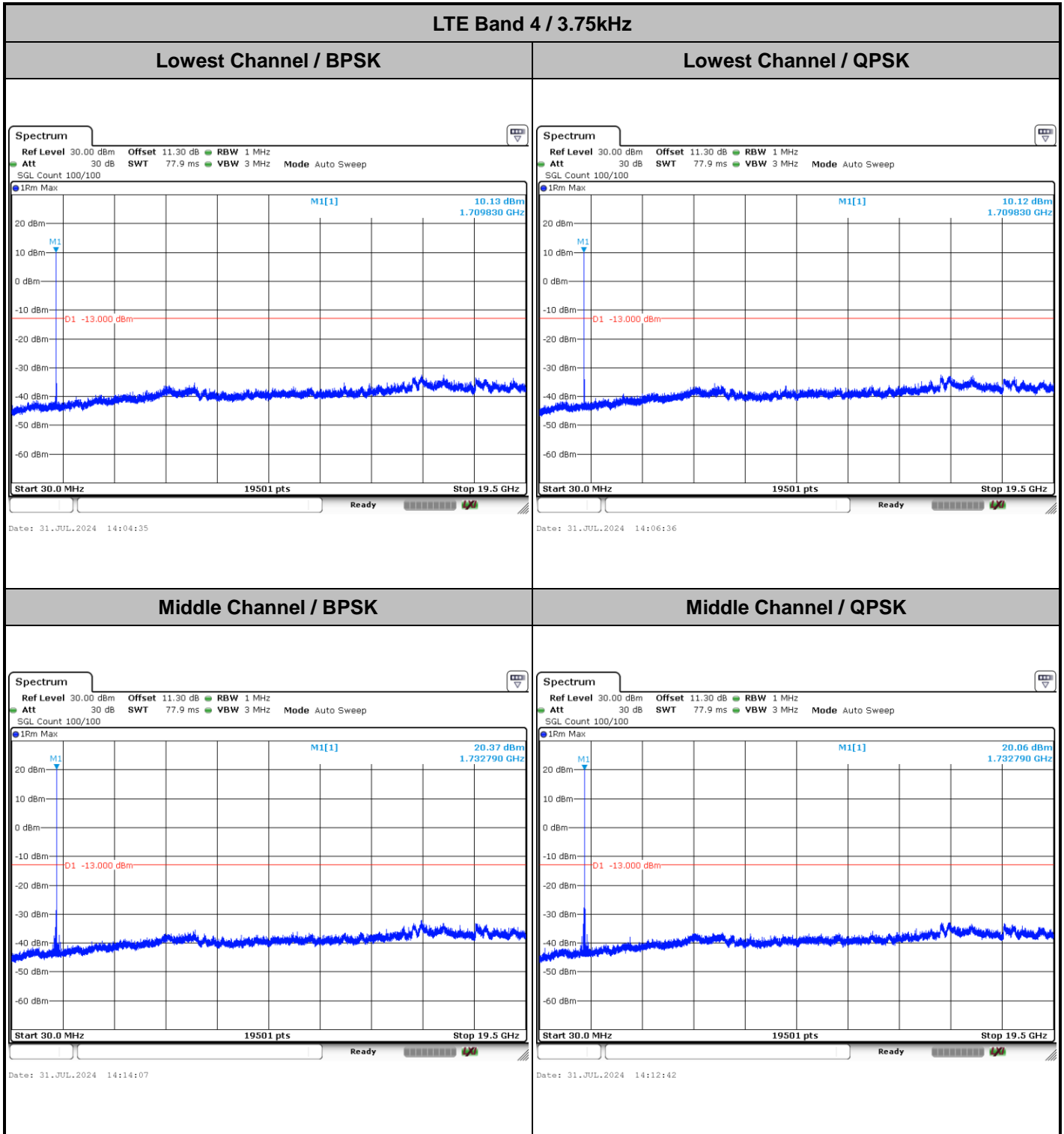



LTE Band 4 / 3.75kHz

Highest Channel / BPSK

Highest Channel / QPSK

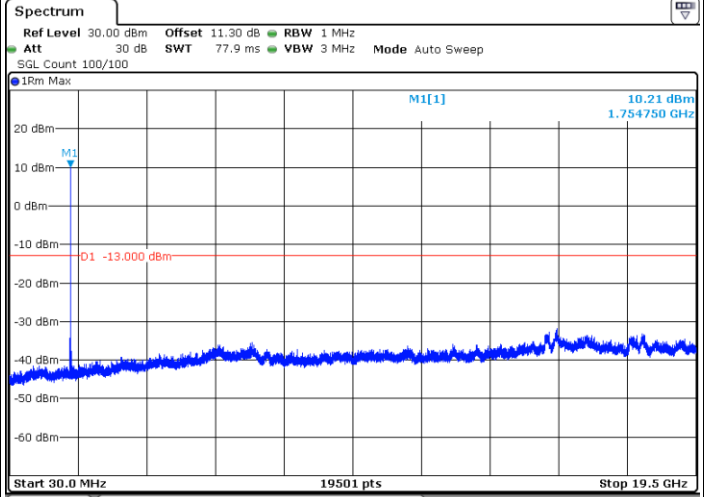
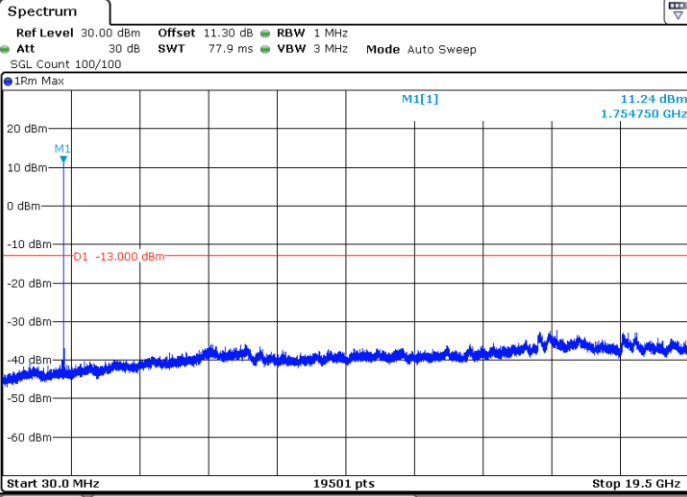

Date: 31.JUL.2024 14:16:24

Date: 31.JUL.2024 14:17:23



LTE Band 4 / 15kHz

Lowest Channel / BPSK

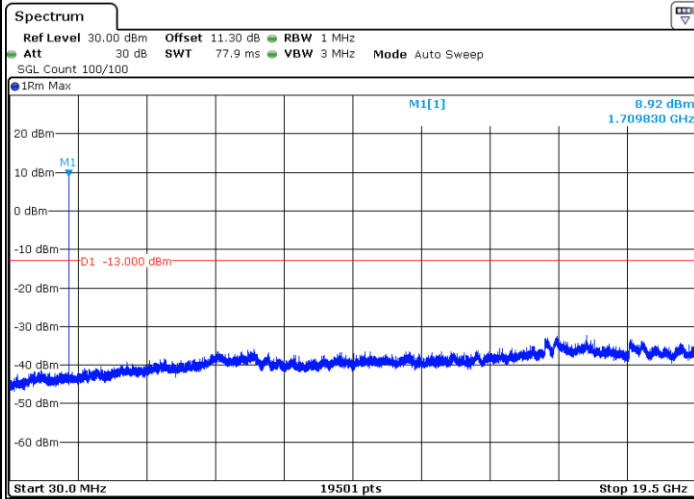

Date: 31.JUL.2024 16:25:49

Lowest Channel / QPSK

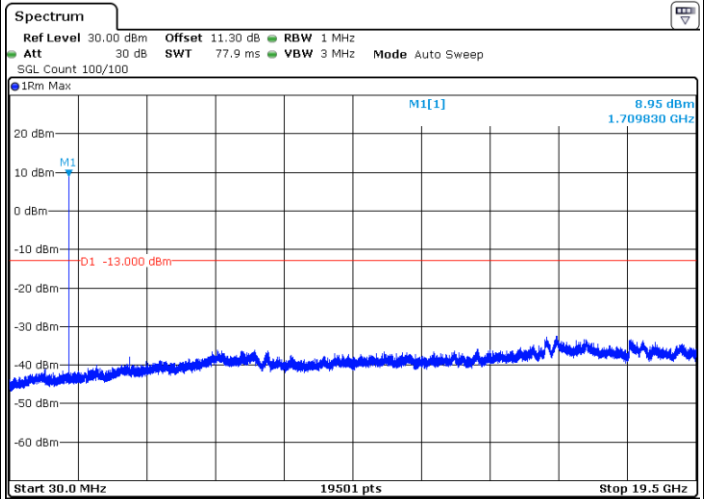

Date: 31.JUL.2024 16:24:33

Middle Channel / BPSK

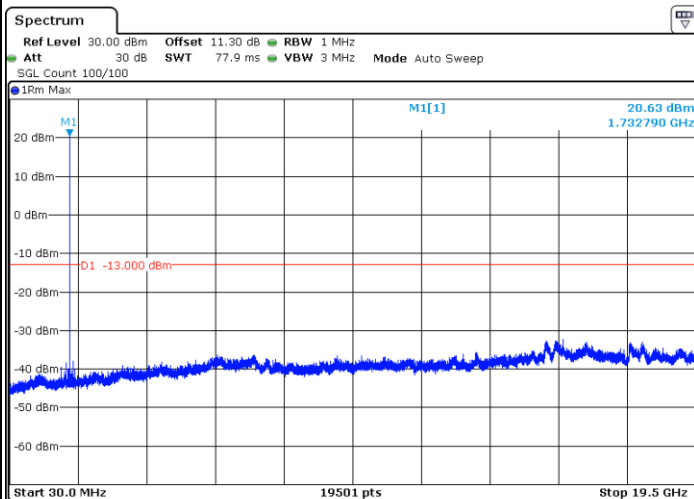

Date: 31.JUL.2024 16:31:55

Middle Channel / QPSK

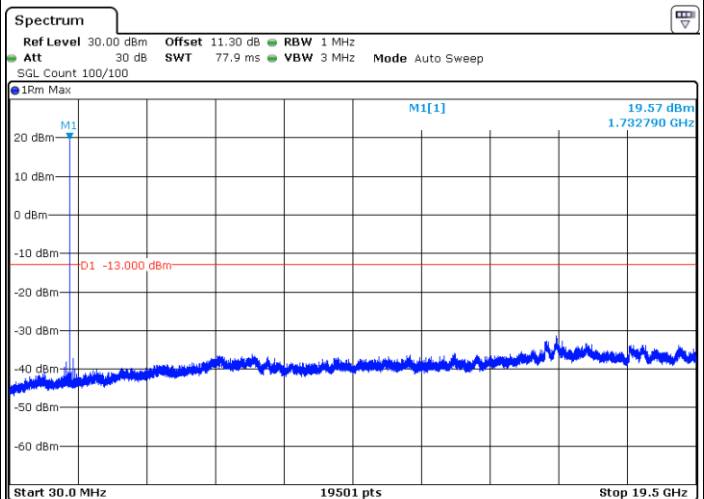

Date: 31.JUL.2024 16:32:52



LTE Band 4 / 15kHz

Highest Channel / BPSK

Highest Channel / QPSK

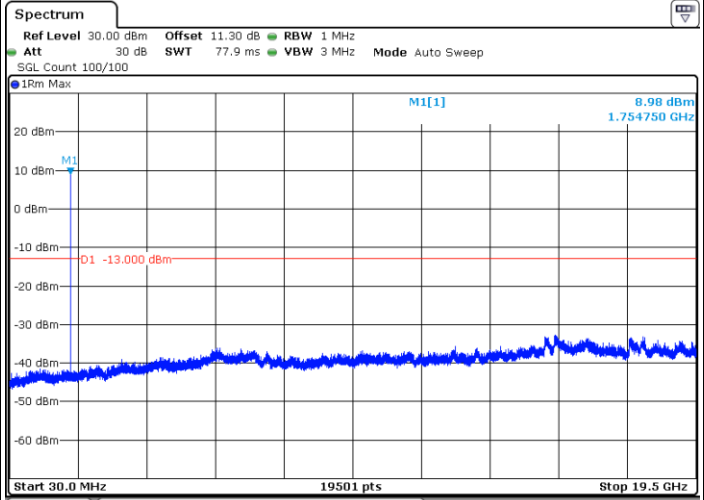
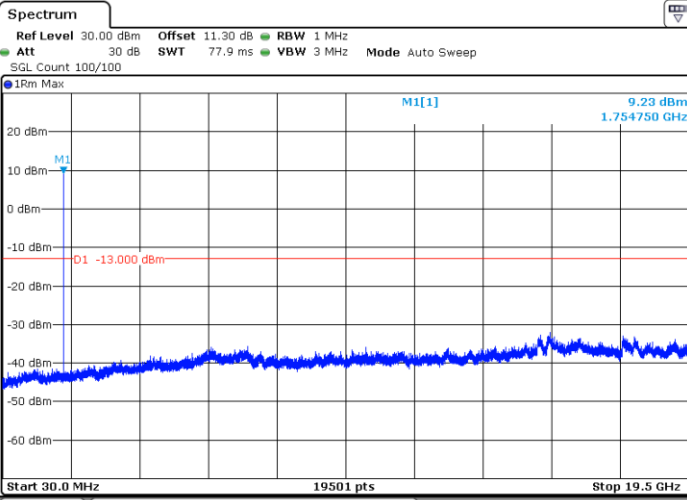

Date: 31.JUL.2024 16:44:27

Date: 31.JUL.2024 16:42:53



Frequency Stability

Test Conditions		LTE Band 4 (QPSK) / Middle Channel	Limit
Temperature (°C)	Voltage (Volt)	BW 15kHz	Note 2.
		Deviation (ppm)	Result
50	Normal Voltage	0.0045	PASS
40	Normal Voltage	0.0029	
30	Normal Voltage	0.0056	
20(Ref.)	Normal Voltage	0.0000	
10	Normal Voltage	0.0007	
0	Normal Voltage	0.0001	
-10	Normal Voltage	0.0021	
-20	Normal Voltage	0.0033	
-30	Normal Voltage	0.0015	
20	Maximum Voltage	0.0010	
20	Normal Voltage	0.0000	
20	Minimum Voltage	0.0013	

Note:

- 1. Normal Voltage = 110 V. ; Minimum Voltage = 90 V. ; Maximum Voltage = 264 V.
- 2. The frequency fundamental emissions stay within the authorized frequency block.



LTE Band 5

Peak-to-Average Ratio

Mode	LTE Band 5 / 15kHz			
Mod.	BPSK	QPSK		Limit: 13dB
T Size	1T	1T	Full T	Result
Lowest CH	2.64	2.09	4.09	PASS
Middle CH	2.52	2.06	4.03	
Highest CH	2.64	2.12	4.12	



LTE Band 5 / 15kHz / BPSK

Lowest Channel / 1T

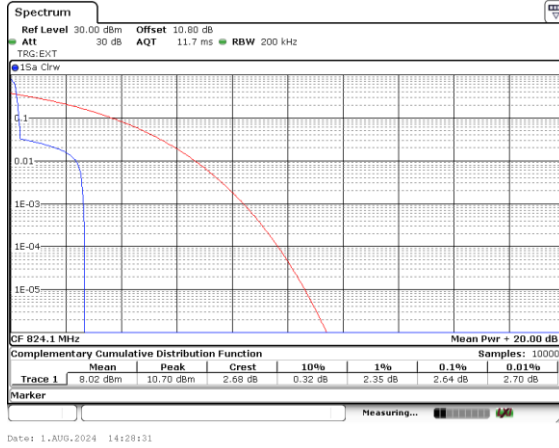

Middle Channel/ 1T

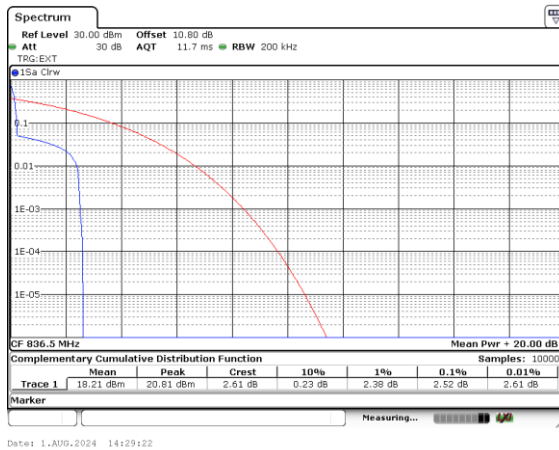

Highest Channel/ 1T

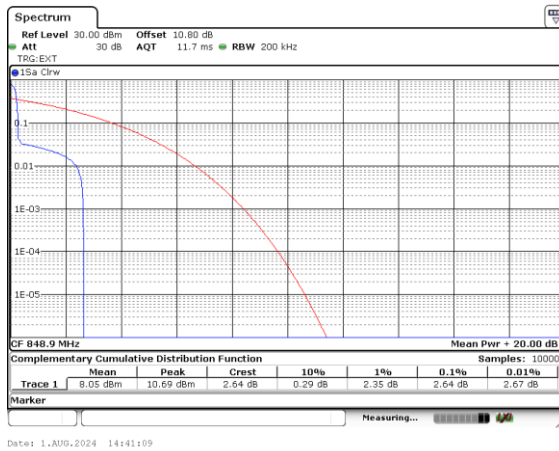



LTE Band 5 / 15kHz / QPSK

Lowest Channel / 1T

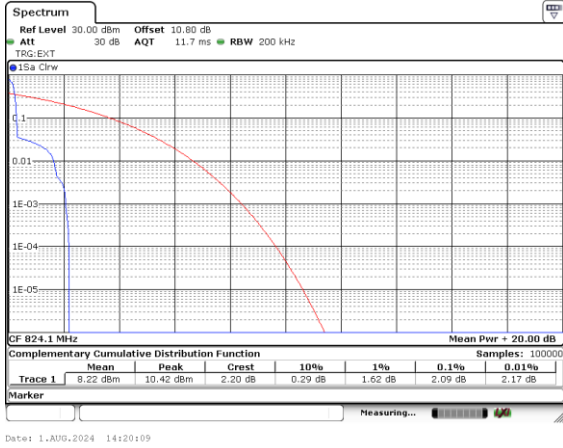

Lowest Channel / Full T

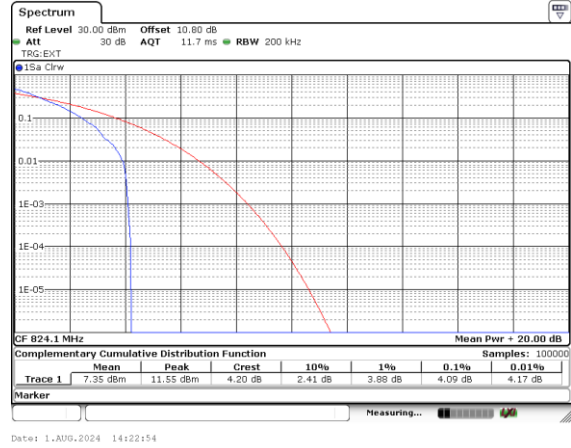

Middle Channel/ 1T

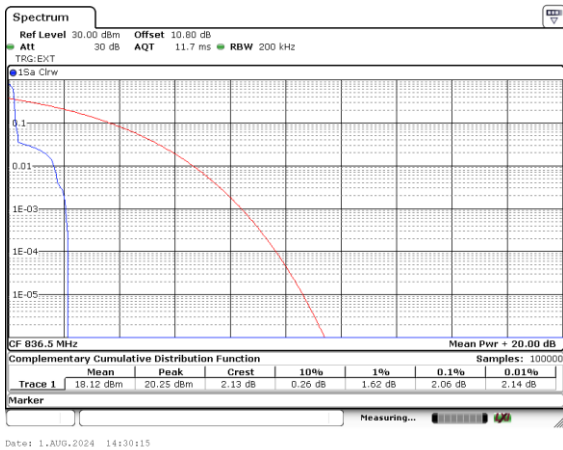

Middle Channel / Full T

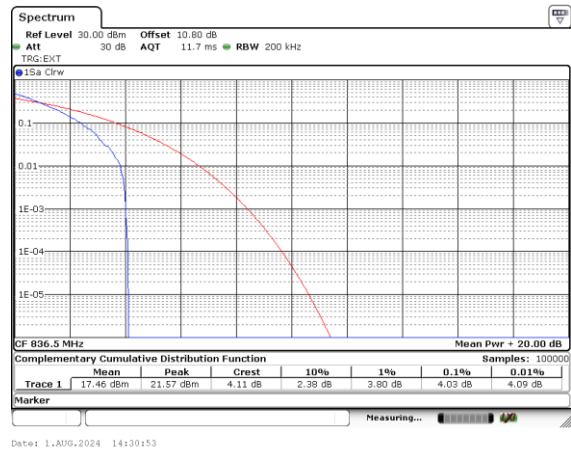

Highest Channel/ 1T

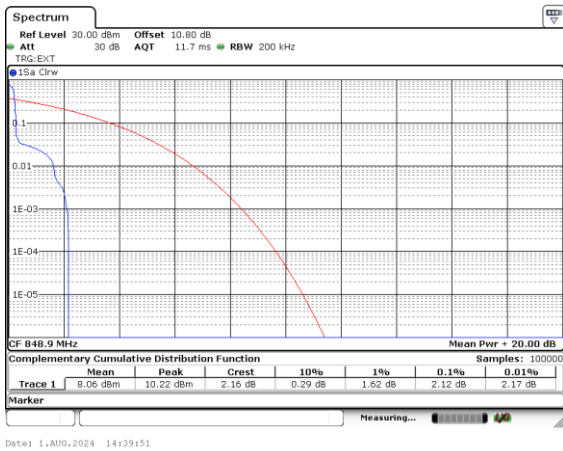

Highest Channel / Full T

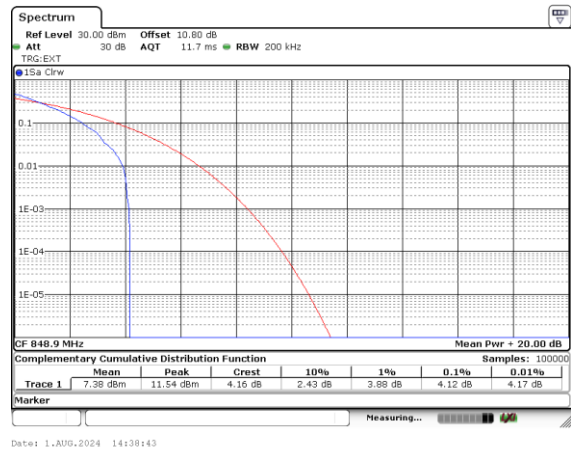



26dB Bandwidth

Mode	LTE Band 5 : 26dB(kHz)
Subcarrier Spacing	15k
Mod.	QPSK
Lowest CH	217.38
Middle CH	217.78
Highest CH	216.58



LTE Band 5

Lowest Channel / 15kHz / QPSK

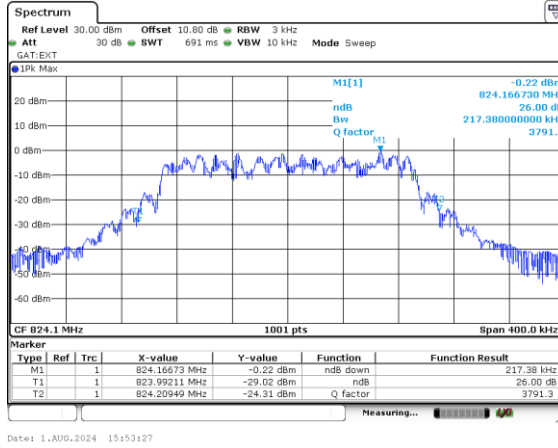

Date: 1.AUG.2024 15:53:27

Middle Channel / 15kHz / QPSK

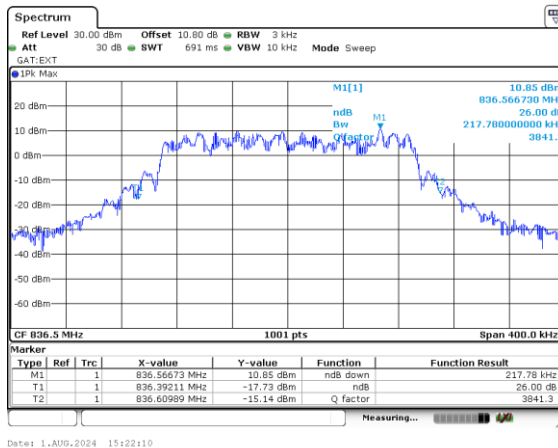

Date: 1.AUG.2024 15:22:10

Highest Channel / 15kHz / QPSK

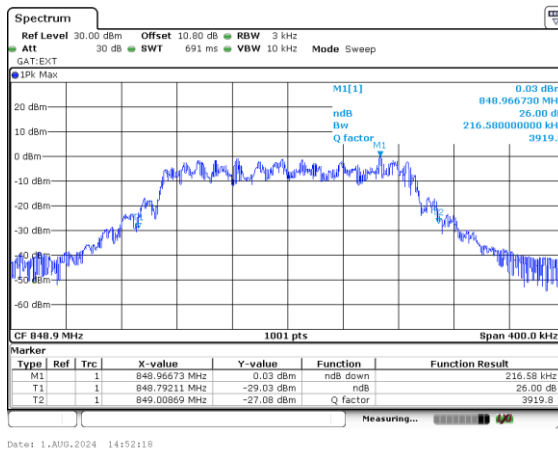

Date: 1.AUG.2024 14:52:18



Occupied Bandwidth

Mode	LTE Band 5 : OB(kHz)
Subcarrier Spacing	15k
Mod.	QPSK
Lowest CH	184.62
Middle CH	184.22
Highest CH	184.22



LTE Band 5

Lowest Channel / 15kHz / QPSK

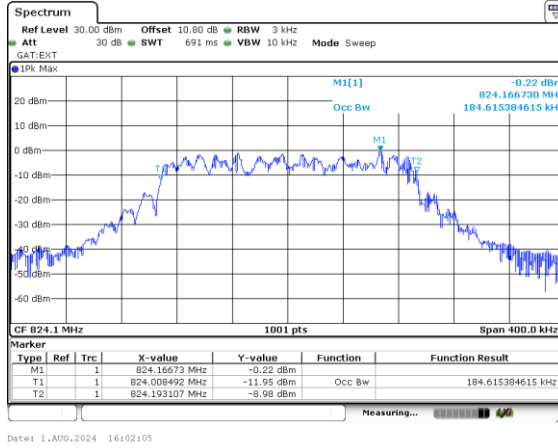

Middle Channel / 15kHz / QPSK

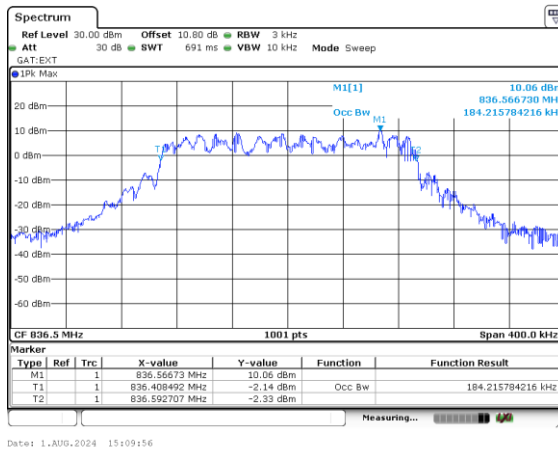

Highest Channel / 15kHz / QPSK

