

ANZZI®

ITEM: EF-AZ103WH

ANZZI EXHAUST FAN
INSTALLATION & OPERATION MANUAL

V1.0
01/05/2024

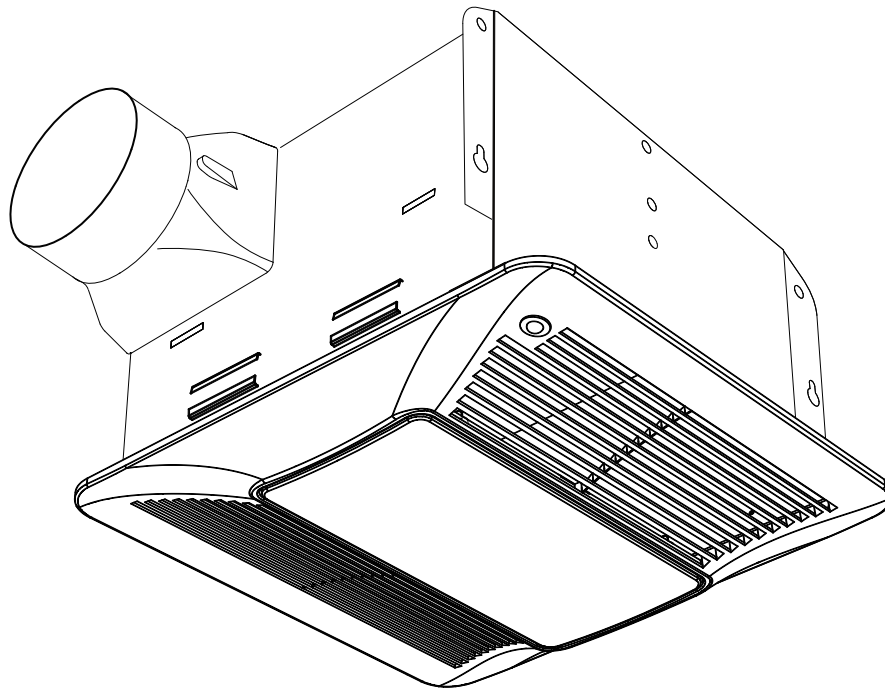

DON'T WAIT! REGISTER NOW!

Register your product within 90 days to ensure your product is recognized as an official purchase and is eligible for warranty coverage.

Mail in the completed registry card (Pg. 2) or register online at <https://register.anzzihome.com/register/>.



PRODUCT REGISTRATION*

IMPORTANT: Warranty will not be recognized unless product is registered.

We offer two options to register your product.

- 1. **Register online at <https://register.anzzihome.com/register/>** or Scan the QR code below. Registering online is fast, secure, and ensures we receive your information.

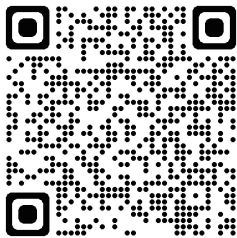

- 2. **Complete, cut out, and mail the registration card below.** Returning this registration card will ensure your product's warranty and allow us to process any warranty claims.

Mail the card to: 5701 NW 35 Avenue, Miami, FL 33142



Product Registration Card

Name..... Address

City.....State..... Zip.....

Phone Email.....

Date of Purchase Order or Purchase # SKU or Model #

Installer's NamePhone

I have read the Owner's Manual carefully and understand and agree that any installation, operation or maintenance of the product must be done strictly in accordance with instructions and guidelines contained in the owner's manual and installation guide.

Signature..... Date.....

Need help? For technical support call 305-614-4070 or visit us at www.ANZZI.com

PRODUCT SIZE CHART

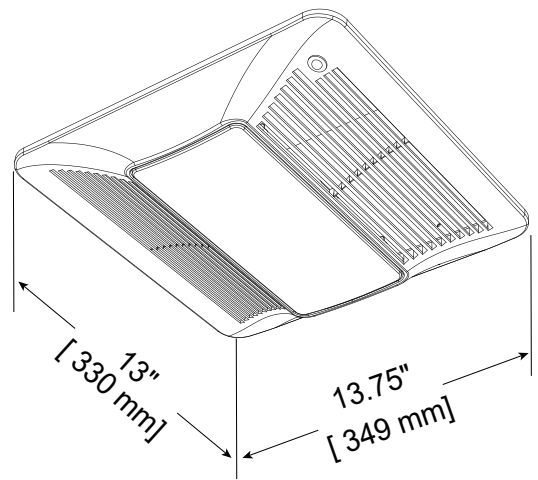
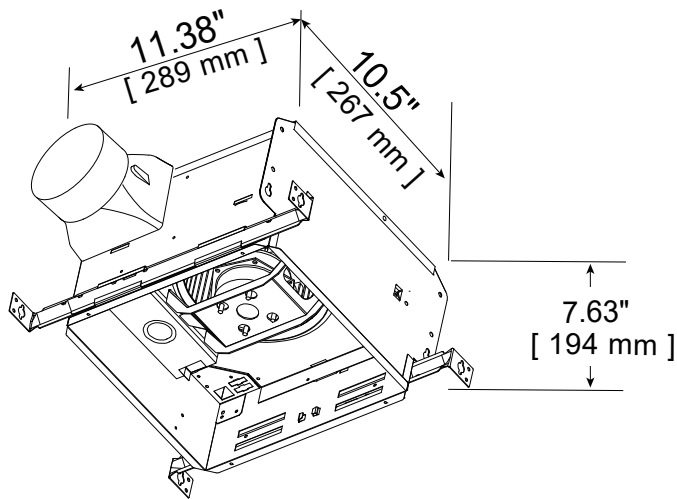

COMPONENTS

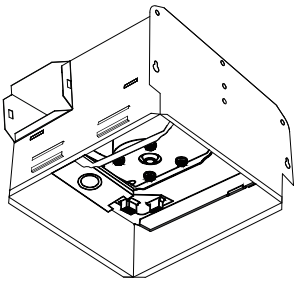

[1]

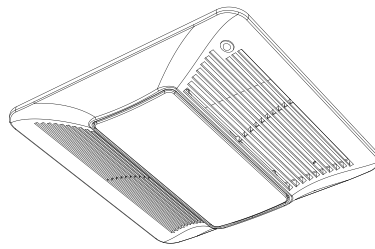

[2]

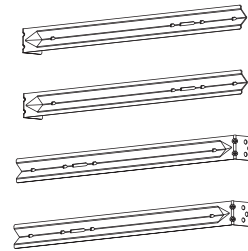

[3]



[4]

[5]

PART	Description	Qty.
1	Fan Body	1
2	Grille Assembly	1
3	Brackets	4
4	Long Screws (#8 x 0.98")	4
5	Short Screws (#8 x 0.51")	2
6	Duct Connector	1

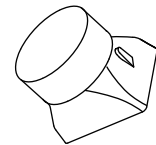

[6]

TOOLS AND MATERIALS

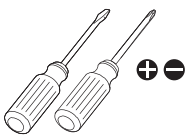

Screwdriver



Jab saw

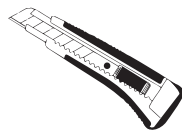

Utility knife



Gloves



Goggles



Duct tape

Thank you for purchasing an ANZZI Exhaust Fan. Please read and follow the installation and operation instructions carefully, to ensure the long life and reliable operation of this appliance. **FAILURE TO DO SO COULD CAUSE PROPERTY DAMAGE, SERIOUS INJURY, OR DEATH.** Please keep this manual for future reference.

SAFETY PRECAUTIONS

READ AND SAVE THESE INSTRUCTIONS

WARNING

TO REDUCE THE RISK OF FIRE, ELECTRIC SHOCK, OR INJURY TO PERSONS, OBSERVE THE FOLLOWING:

- Use this unit only in the manner intended by the manufacturer. If you have questions, contact the manufacturer.
- Before servicing or cleaning unit, switch power off at service panel and lock the switch to prevent power from being switched on accidentally. When the switch cannot be locked, securely fasten a prominent warning device, such as a tag, to the service panel.
- Installation work and electrical wiring must be done by qualified person(s) in accordance with all applicable codes and standards, including fire-rated construction.
- When cutting or drilling into wall or ceiling, do not damage electrical wiring and other hidden utilities.
- Ducted fans must always be vented to the outdoors.

CAUTION

- For General Ventilating Use Only. Do Not Use To Exhaust Hazardous Or Explosive Materials And Vapors.
- IN USA: INSTALL FAN AT LEAST 7 FEET (2.1M) ABOVE FLOOR. IN CANADA: INSTALL FAN AT LEAST 8.2 FEET (2.5M) ABOVE FLOOR.
- This product is designed for installation in ceilings up to a 12/12 pitch (45 degree angle). Duct connector must point up. DO NOT MOUNT THIS PRODUCT IN A WALL.
- To avoid motor bearing damage and noisy and/or unbalanced impellers, keep drywall spray, construction dust, etc. off power unit.

- Sufficient air is needed for proper combustion and exhausting of gases through the flue (chimney) of fuel burning equipment to prevent back drafting. Follow the heating equipment manufacturer's guideline and safety standards such as those published by the National Fire Protection Association (NFPA), and the American Society for Heating, Refrigeration and Air Conditioning Engineers (ASHRAE), and the local code authorities.
- If this unit is to be installed over a tub or shower, it must be marked as appropriate for the application and be connected to a GFCI (Ground Fault Circuit Interrupter) protected branch circuit.
- To Reduce The Risk Of Fire Or Electric Shock, Do Not Use This Fan With Any Solid-State Speed Control Device.
- NEVER place a switch where it can be reached from a tub or shower.
- This unit must be grounded.
- Not for use in cooking area. (See Fig 1)
- Please read specification label on product for further information and requirements.

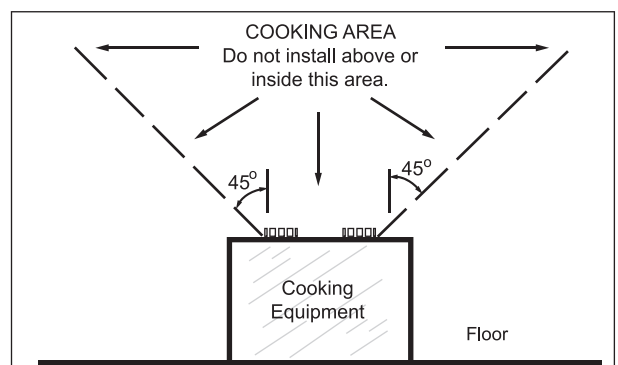

Fig 1

NOTICE

- Follow all local electrical and safety codes, as well as the National Electrical Code (NEC) and the Occupational Safety and Health Act (OSH Act).
- Always disconnect the power source before working on or near the ventilating fan, motor or junction box.
- Make sure that the electric service supply voltage is AC 120V, 60Hz.
- Protect the power cord from sharp edges, oil, grease, hot surfaces, chemicals or other objects.

- Do not kink the power cord.
- Do not install the unit where ducts are configured as shown in Fig 2.

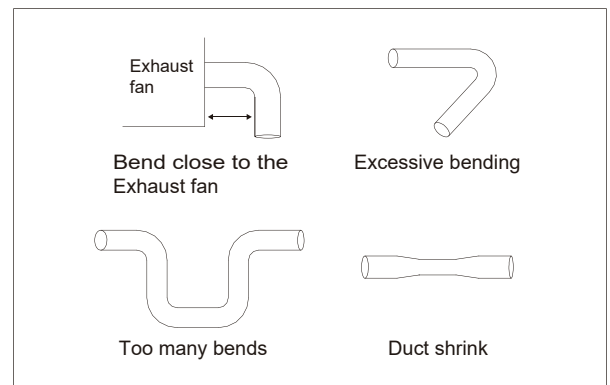

Fig 2

FEATURES AND SETTINGS

- Turning the " H " adjuster will change the humidity sensing level. When the detected humidity reaches the pre-set level, the fan will be switched to the maximum speed.
- Turning the " T " adjuster will change the time of the fan working at maximum speed after the humidity of room is lower than the pre-set humidity sensing level.
- The " Toggle switch " controls the suction of air. When the humidity is lower than the sensor setting, the fan will keep working at maximum speed until the pre-set time is up. Then the fan will operate at the speed pre-set by toggle switch.
- This exhaust fan is integrated with a wireless speaker. You can connect it with your phones or devices which have bluetooth connections and stream audio.

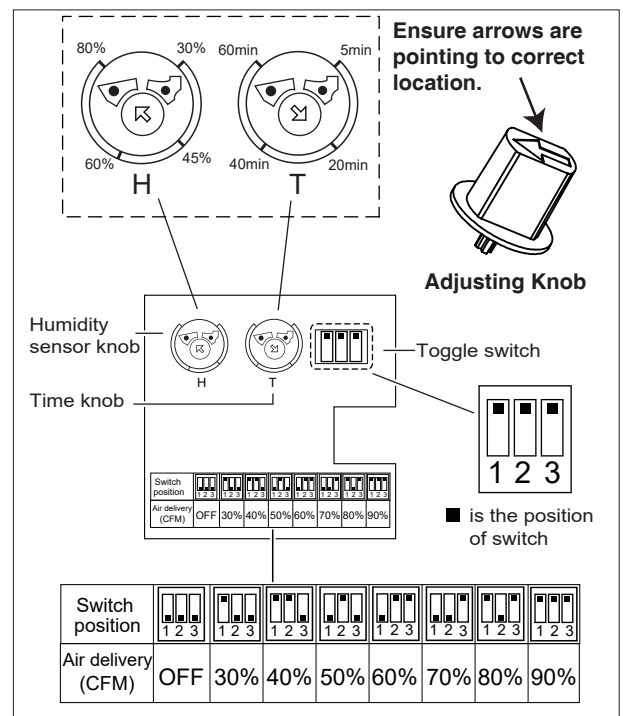

Fig 3

MOTION SENSOR

This exhaust fan unit features a motion sensor. While on, any movement within the sensing area will activate the exhaust fan at its maximum speed. The sensing area radius is equal to the exhaust fan's height. The fan slows down to pre-set speeds when the sensing area is unoccupied, the humidity is low, and the timer is up.

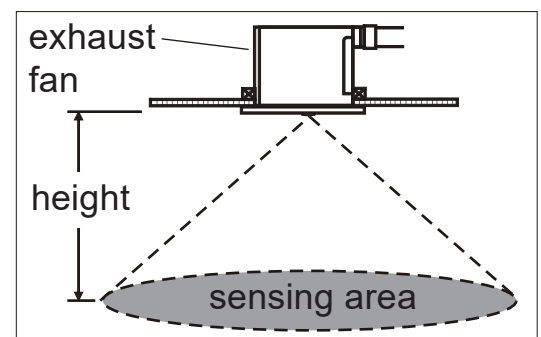

Fig 4

FEATURES AND SETTINGS

HUMIDITY SENSING LEVEL

- Install an Adjusting Knob to the "H" adjuster with the arrow on it pointing to 80% to adjust the humidity sensing level.
- The humidity sensing level is pre-set at 80%. When the detected humidity reaches the pre-set level, the fan will be switched to the maximum speed.

TOGGLE SWITCH

- There are three toggles on the toggle switch. Adjust the toggles as shown in fig 3 to set the CFM of the air suction when the maximum speed time of the fan is up. If the toggles are moved to the " OFF " setting, the fan will stop working after the maximum speed time is up. The toggle switch is pre-set to 90% CFM.

CAUTION

When installing Humidity and Time knobs, make sure the arrows are pointing to the correct location as picture shows in Fig 3.

INSTALLATION GUIDELINE

CAUTION

1. Install this fan in a GFCI protected branch circuit.
2. Check area above installation location to be sure that wiring can run to the planned location and that ductwork can be run. Make sure the area is sufficient for proper ventilation.
3. Inspect duct work and wiring before proceeding with installation.

Note: Not all parts necessary for the installation of your exhaust fan are included. However, most are available at your local home improvement or hardware store.
4. Make sure there is adequate space for installation with 11.38" x 10.5"(duct direction) x 7.63"(Height).
5. Install proper insulation around the fan to minimize building heat loss and gain. 4" circular duct is needed for installation. The ducting from this fan to the outside of the building has a strong effect on the air flow, noise and energy use of the fan. Use the shortest, straightest duct routing possible for best performance, and avoid installing the fan with smaller ducts than recommended. Insulation around the ducts can reduce energy loss and inhibit mold growth. Fans installed with existing ducts may not achieve their rated air flow.
6. Use a roof cap or wall cap that has a built-in damper to reduce backdrafts.

INSTALLATION EXAMPLE

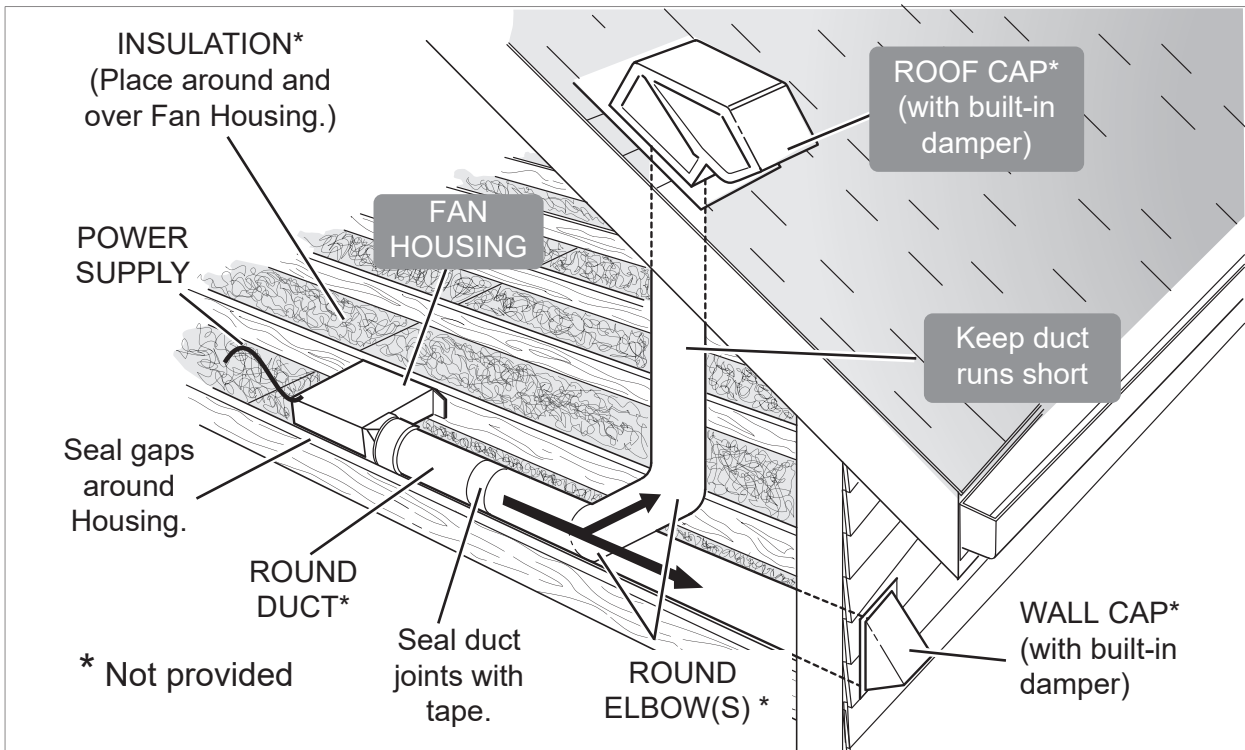

Fig 5

INSTALLATION

CAUTION

Shut down power supply at breaker box before starting installation.

NOTICE

- You may need the help of a second person to install this fan—one person on the attic side and one on the room side.
- Be careful to cut hole to the correct size. If hole is too big, the fan grille will not hide it.
- Installing the fan body in an existing building requires an accessible area (attic or crawl space) above the planned installation location and existing duct and wiring.
- Make sure there is space with 11.38" x 10.5" (duct direction) x 7.63"(Height).
- This fan can be installed to 11.5" - 24" between the joist or to I-joists, standard joists and truss construction.

INSTALLATION

Step 1 - There are two ways to install the fan. Choose the suitable one to follow below.

MOUNTING THE FAN TO THE JOIST, I-JOIST OR TRUSS DIRECTLY

Notice: Additional framing in 2" X 6" section size would be needed for "I" joist or joist and truss which are less than 6".

1. Position and hold the Fan Body [1] to the joist (truss or framing). Make sure the flange of housing is flush to the surface of joist.
2. Secure the tabs with Long Screws [4] as figure shows. (Fig 6)

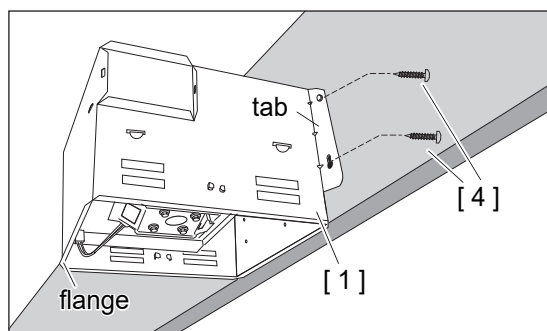

Fig 6

MOUNTING THE FAN TO THE JOIST, I-JOIST OR TRUSS WITH BRACKETS

1. Insert two Brackets [3] to the duct side and two Brackets [3] to back of the Fan Body [1] as figure shows. (Fig 7)
2. Insert the Fan Body [1] between joists. (Fig 8)
Note: Make sure the Fan Body [1] is level and perpendicular with the joist, and flush with the surface of the joists which are connected to the ceiling surface.
3. Secure the Brackets [3] to joists with the Long Screws [4]. (Fig 8)
4. Find the hole in the center of each overlapped pair of Brackets [3]. Install one Short Screw [5] in each hole, close to the middle of the Fan Body [1]. (Fig 8)

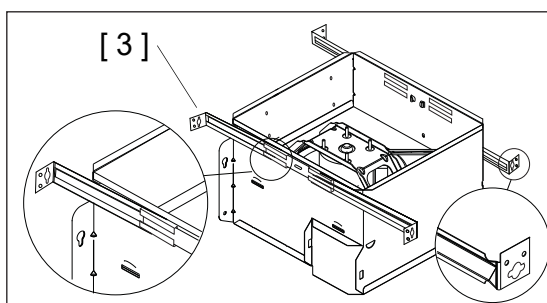

Fig 7

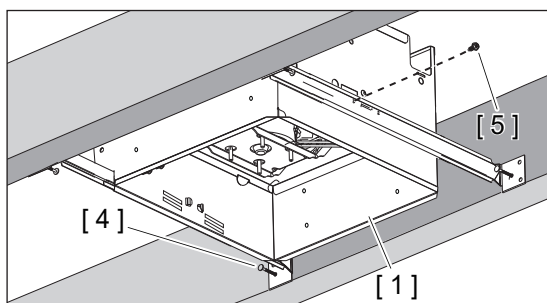

Fig 8

Step 2

1. Install the Duct Connector [6] and make sure the damper is at the right place and can flip freely. Connect the 4" round ductwork (not provided) to the duct connector, and run the ductwork to a roof or wall cap (not provided).
2. Using tape (not included), secure all the ductwork connections so that they are air tight.
Note: Use the shortest, straightest duct routing possible for best performance, and avoid installing the fan with smaller ducts than recommended. Insulation around the ducts can reduce energy loss and inhibit mold growth. Fans installed with existing ducts may not achieve their rated air flow.

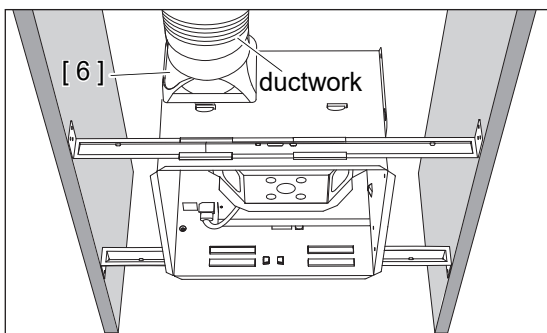

Fig 9

INSTALLATION

Step 3

Run 120 VAC house wiring to the location of the fan. Use only UL-approved Wire Nut (Not provided) to attach the house wiring to the wiring plate. Refer to the wiring diagram, and connect the wires as shown.

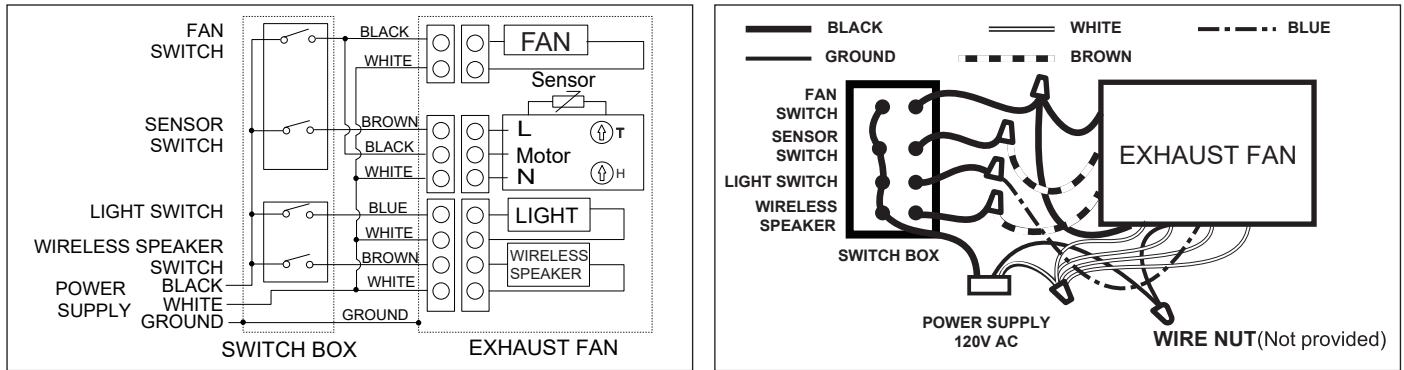

Fig 10

Step 4

1. Install ceiling material to complete the ceiling construction. Then, cut around the fan housing.
2. Remove dust from the Fan Body [1] with a vacuum cleaner. Do not use abrasive cloths, steel wool pads, or scouring powders. Never use solvents, thinner or harsh chemicals when cleaning the fan.
3. Plug the Light Connector into the receptacle of the Fan Body [1].
4. Plug the Motion Sensor Connector to the connector from the Fan Body [1].

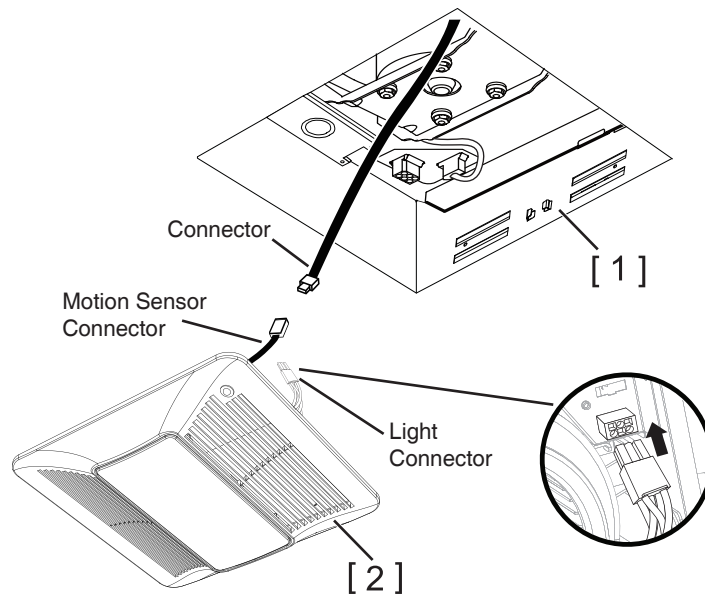

Fig 11

INSTALLATION

Step 5

1. Pinch the Springs of Grille Assembly [2] on the sides and insert the Springs into the Slots in Fan Body [1]. Then, push the Grille Assembly [2] towards the ceiling to secure.

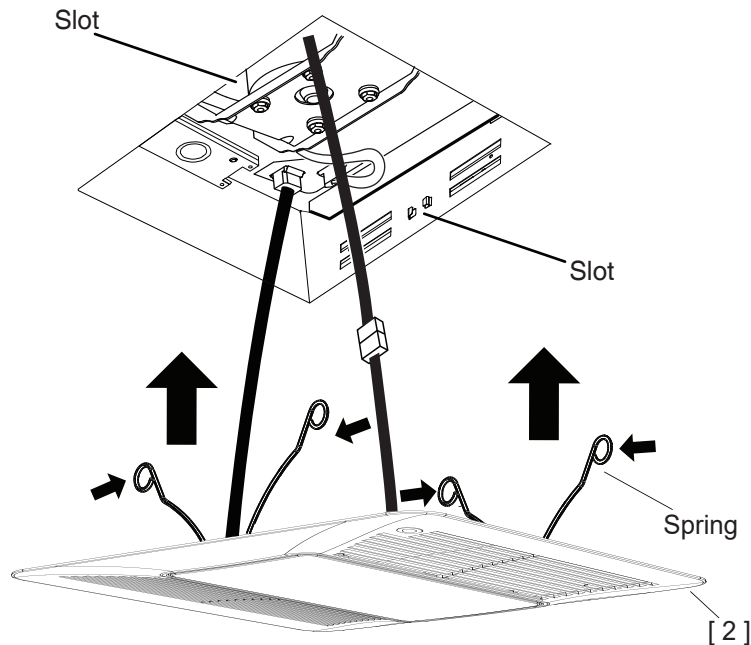

Fig 12

OPERATING INSTRUCTIONS

WARNING

This EXHAUST FAN must be properly installed before it is used.

1. Turn on the Light Switch to turn on the LED light.
2. Turn on the Sensor Switch to start the fan. The fan will operate under pre-set speed. When the humidity of the room reaches the pre-set humidity level, the fan will switch to the maximum speed to exhaust the air.
3. When the fan isn't working at the maximum speed, turn on the Fan Switch to adjust the fan to the maximum speed to exhaust the air continuously. Turn off the Fan Switch so that the fan goes back to the humidity sensor controlled mode.
4. Turn on the Wireless Speaker Switch to activate the wireless speaker. Turn on the bluetooth function on your phones or other devices. Pair them with the "wireless speaker" to stream audio through the speaker.

CLEANING AND MAINTENANCE

WARNING

Always disconnect the power source before working on the ventilating fan.

1. Pull down the Grille Assembly [2] and squeeze springs to pull it out from the Fan Body [1]. Unplug the Grille Assembly [2] from Fan Body [1].
2. Remove dust and dirt from the Fan Body [1] with a vacuum cleaner. Do not use abrasive cloths, steel wool pads, or scouring powders. Never use solvents, thinners or harsh chemicals when cleaning the fan.
3. Plug the Grille Assembly [2] back into the receptacle of the Fan Body [1]. Install the Grille Assembly [2] back to the Fan Body [1].

TROUBLE SHOOTING

SYMPTOMS	POSSIBLE CAUSE	RECOMMENDED ACTIONS
The fan is not turning on	<ol style="list-style-type: none">1. Power off2. Faulty switch3. Faulty wire connection	<ol style="list-style-type: none">1. Make sure power supply is on.2. Test or replace switch.3. Check wire in switch box.
The fan seems louder than it should	<ol style="list-style-type: none">1. CFM rating is too high for room2. Damper not working properly or damaged3. Bend in duct too close to fan discharge4. Fan discharge reduced to fit smaller duct5. Fan body not securely attached	<ol style="list-style-type: none">1. Be sure the CFM rating on the fan matches the size of your room.2. Check damper to ensure it is opening and closing properly. If the damper has become damaged, please call Customer Service.3. Be sure you do not have any sharp bends in duct closer than 18 in. to the fan discharge.4. Use recommended size ducting to reduce fan noise.5. Be sure the fan is securely attached to your ceiling joists.
The fan is not clearing the room	<ol style="list-style-type: none">1. Insufficient intake airflow within room2. Insufficient CFM	<ol style="list-style-type: none">1. Be sure a door or window is slightly ajar or opened to allow airflow. The fan is not able to draw air out of the room without enough airflow to draw in from.2. Be sure the CFM rating on the fan matches the requirements for your room size.

FCC CAUTION:

This device complies with part 15 of the FCC Rules. Operation is subject to the following two conditions: (1) This device may not cause harmful interference, and (2) this device must accept any interference received, including interference that may cause undesired operation.

Any changes or modifications not expressly approved by the party responsible for compliance could void the user's authority to operate the equipment.

NOTE: This equipment has been tested and found to comply with the limits for a Class B digital device, pursuant to part 15 of the FCC Rules. These limits are designed to provide reasonable protection against harmful interference in a residential installation. This equipment generates, uses and can radiate radio frequency energy and, if not installed and used in accordance with the instructions, may cause harmful interference to radio communications. However, there is no guarantee that interference will not occur in a particular installation. If this equipment does cause harmful interference to radio or television reception, which can be determined by turning the equipment off and on, the user is encouraged to try to correct the interference by one or more of the following measures:

- Reorient or relocate the receiving antenna.
- Increase the separation between the equipment and receiver.
- Connect the equipment into an outlet on a circuit different from that to which the receiver is connected.
- Consult the dealer or an experienced radio/TV technician for help.

The equipment complies with FCC radiation exposure limits set forth for an uncontrolled environment.

This transmitter must not be co-located or operating in conjunction with any other antenna or transmitter.

The equipment should be installed and operated with minimum 20cm distance between the radiator and your body.



ANZZI®