

TEST REPORT

Report No.: SHATBL2304004W02

Applicant : Jiangsu Shushi Technology Co., Ltd.

Product Name : Smart Hub Gen2 Plus

Brand Name : N/A

Model Name : 3RSH05027BWZ

FCC ID : 2BAGQ-3RSH05027BWZ

Test Standard : FCC Part15.247

Date of Test : 2023.4.08-2023.04.10

Report Prepared by :

Chris Xu

(Chris Xu)

Report Approved by :

Ghost Li.

(Ghost Li)

Authorized Signatory :

Terry Yang

(Terry Yang)



"Shanghai ATBL Technology Co., Ltd." hereby certifies that according to actual testing conditions. The test results or observations are provided in accordance with measured value, without taking risks caused by uncertainty into account. Without explicit stipulation in special agreements, standards, or regulations, ATBL shall not assume any responsibility. The test results or observations are applicable only to tested sample. Client shall be responsible for representativeness of the sample and authenticity of the material. This report will be void without authorized signature or special seal for testing report. Do not copied without authorization.

GENERAL DESCRIPTION

Applicant's Name.....: Jiangsu Shushi Technology Co., Ltd.
Address.....: NO.9 Nanxu Road,RunZhou District,Zhenjiang,Jiangsu,China
Manufacture's Name.....: Jiangsu Shushi Technology Co., Ltd.
Address.....: NO.9 Nanxu Road,RunZhou District,Zhenjiang,Jiangsu,China

Product Description

Product Name.....: Smart Hub Gen2 Plus
Brand Name: N/A
Model Name.....: 3RSH05027BWZ
Series Model.....: N/A
Test Standards.....: FCC Part15.247
Test Procedure.....: ANSI C63.10-2013

The device has been tested by ATBL, and the test results show that the equipment under test (EUT) is in compliance with the FCC Part15.247 requirements. And it is applicable only to the tested sample identified in the report.

This report shall not be reproduced except in full, without the written approval of ATBL, this document only be altered or revised by ATBL, personal only, and shall be noted in the revision of the document.

Date of receipt of test item.....: 2023.04.04
Date (s) of performance of tests.....: 2023.4.08-2023.04.10
Date of Issue.....: 2023.04.17
Test Result.....: **Pass**

TABLE OF CONTENTS

1. SUMMARY OF TEST RESULTS 6

2. GENERAL INFORMATION 7

 2.1 GENERAL DESCRIPTION OF THE EUT 7

 2.2 DESCRIPTION OF THE TEST MODES 8

 2.3 TEST SOFTWARE AND POWER LEVEL 9

 2.5 DESCRIPTION OF NECESSARY ACCESSORIES AND SUPPORT UNITS 10

 2.6 LABORATORY INFORMATION 10

 2.7 MEASUREMENT UNCERTAINTY 10

 2.8 EQUIPMENTS LIST 11

3. EMC EMISSION TEST 12

 3.1 CONDUCTED EMISSION MEASUREMENT 12

 3.2 TEST PROCEDURE 13

 3.3 TEST SETUP 13

 3.4 EUT OPERATING CONDITIONS 13

 3.5 TEST RESULTS 14

4. RADIATED EMISSION MEASUREMENT 16

 4.1 RADIATED EMISSION LIMITS 16

 4.2 TEST PROCEDURE 18

 4.3 TEST SETUP 19

 4.4 EUT OPERATING CONDITIONS 19

 4.5 FIELD STRENGTH CALCULATION 20

 4.6 TEST RESULTS 20

5. CONDUCTED SPURIOUS & BAND EDGE EMISSION 33

 5.1 LIMIT 33

 5.2 TEST PROCEDURE 33

 5.3 TEST SETUP 33

 5.4 EUT OPERATION CONDITIONS 33

 5.5 TEST RESULTS 34

6. POWER SPECTRAL DENSITY TEST 35

 6.1 LIMIT 35

 6.2 TEST PROCEDURE 35

 6.3 TEST SETUP 35

 6.4 EUT OPERATION CONDITIONS 35

 6.5 TEST RESULTS 36

7. BANDWIDTH TEST 37

 7.1 LIMIT 37

 7.2 TEST PROCEDURE 37

 7.3 TEST SETUP 37

7.4 EUT OPERATION CONDITIONS 37

7.5 TEST RESULTS 38

8. PEAK OUTPUT POWER TEST 39

8.1 LIMIT 39

8.2 TEST PROCEDURE 39

8.3 TEST SETUP 39

8.4 EUT OPERATION CONDITIONS 39

8.5 TEST RESULTS 40

9. ANTENNA REQUIREMENT 41

9.1 STANDARD REQUIREMENT 41

9.2 EUT ANTENNA 41

10. APPENDIX- PHOTOS OF TEST SETUP 42

Revision History

Rev.	Issue Date	Report NO.	Effect Page	Contents
00	2023.04.17	SHATBL2304002W02	ALL	Initial Issue

1. SUMMARY OF TEST RESULTS

Test procedures according to the technical standards:
KDB 558074 D01 15.247 Meas Guidance v05r02.

FCC Part 15.247, Subpart C			
Standard Section	Test Item	Judgment	Remark
15.207	Conducted Emission	PASS	--
15.247 (a)(2)	6dB&99% Bandwidth	PASS	--
15.247 (b)(3)	Output Power	PASS	--
15.247(d) & 15.209 & 15.205	Radiated Spurious Emission	PASS	--
15.247(d) & 15.205	Conducted Spurious & Band Edge Emission	PASS	--
15.247 (e)	Power Spectral Density	PASS	--
15.205	Restricted bands of operation	PASS	--
15.203	Antenna Requirement	PASS	--

NOTE:

- (1) 'N/A' denotes test is not applicable in this Test Report.
- (2) All tests are according to ANSI C63.10-2013.

2. GENERAL INFORMATION

2.1 GENERAL DESCRIPTION OF THE EUT

Product Name	Smart Hub Gen2 Plus	
Trade Name	N/A	
Model Name	3RSH05027BWZ	
Series Model	N/A	
Model Difference	N/A	
Product Description	The EUT is Smart Hub Gen2 Plus	
	Operation Frequency:	2402~2480 MHz
	Modulation Type:	GFSK
	Radio Technology:	BLE
	Bluetooth Version:	5.0
	Bluetooth Configuration:	BLE(Support 1M PHY)
	Number Of Channel:	40
	Antenna Designation:	Ceramic Antenna
	Antenna Gain (dBi)	2.8dBi
Channel List	Please refer to the Note 2.	
Power Input	DC5V	
Battery	N/A	
Hardware version number	P5_V2.7	
Software version number	02.00.31.00	
Connecting I/O Port(s)	Please refer to the Note 1.	

Note:

1. For a more detailed features description, please refer to the manufacturer's specifications or the User Manual.

2.

Channel List							
Channel	Frequency (MHz)	Channel	Frequency (MHz)	Channel	Frequency (MHz)	Channel	Frequency (MHz)
00	2402	10	2422	20	2442	30	2462
01	2404	11	2424	21	2444	31	2464
02	2406	12	2426	22	2446	32	2466
03	2408	13	2428	23	2448	33	2468
04	2410	14	2430	24	2450	34	2470
05	2412	15	2432	25	2452	35	2472
06	2414	16	2434	26	2454	36	2474
07	2416	17	2436	27	2456	37	2476
08	2418	18	2438	28	2458	38	2478
09	2420	19	2440	29	2460	39	2480

3.

Table for Filed Antenna

Ant.	Model Name	Antenna Type	Connector	Gain (dBi)	NOTE
0	3RSH05027BWZ	Ceramic Antenna	N/A	2.8dBi	BLE ANT

2.2 DESCRIPTION OF THE TEST MODES

For conducted test items and radiated spurious emissions

Each of these EUT operation mode(s) or test configuration mode(s) mentioned below was evaluated respectively.

Worst Mode	Description	Data/Modulation
Mode 1	TX CH00(2402MHz)	1Mbps/GFSK
Mode 2	TX CH19(2440MHz)	1Mbps/GFSK
Mode 3	TX CH39(2480MHz)	1Mbps/GFSK

Note:

(1) The measurements are performed at all Bit Rate of Transmitter, the worst data was reported.

For Conducted Emission

Test Case	
Conducted Emission	Mode 4: Keeping BT TX

2.3 TEST SOFTWARE AND POWER LEVEL

During testing channel & power controlling software provided by the customer was used to control the operating channel as well as the output power level.

RF Function	Type	Mode Or Modulation type	Ant Gain(dBi)	Power Class	Software For Testing
BLE	BLE	GFSK	2.8	15	Provided by the customer

2.4 BLOCK DIGRAM SHOWING THE CONFIGURATION OF SYSTEM TESTED

Radiated Spurious Emission Test



Conduction Test Set



2.5 DESCRIPTION OF NECESSARY ACCESSORIES AND SUPPORT UNITS

The EUT has been tested as an independent unit together with other necessary accessories or support units. The following support units or accessories were used to form a representative test configuration during the tests.

Necessary accessories

Item	Equipment	Mfr/Brand	Model/Type No.	Length	Note
E-2	Adapter	Moveforest	MF-05001000SA1	N/A	N/A
C-1	USB	N/A	20cm	N/A	N/A

Support units

Item	Equipment	Mfr/Brand	Model	Type No.	Note
E-3	Notebook	Lenovo	DESKTOP-USDEO09	00326-10000-00000-AA636	N/A
C-2	USB	N/A	100cm	N/A	N/A

Note:

- (1) The support equipment was authorized by Declaration of Confirmation.
- (2) For detachable type I/O cable should be specified the length in cm in 『Length』 column.

2.6 LABORATORY INFORMATION

Company Name:	Shanghai ATBL Technology Co., Ltd.
Address:	Building 8, No. 160, Basheng Road, Waigaoqiao Free Trade Zone, Pudong New Area, Shanghai
Telephone:	+86(0)21-51298625
The FCC Registration Number (FRN):	0031025281
A2LA Number:	6184.01
CNAS Number:	CNAS L14531

2.7 MEASUREMENT UNCERTAINTY

The reported uncertainty of measurement $y \pm U$, where expanded uncertainty U is based on a standard uncertainty multiplied by a coverage factor of $k=2$, providing a level of confidence of approximately **95** %.

No.	Item	Uncertainty
1	RF output power, conducted	± 0.962 dB
2	Conducted spurious emissions	± 2.986 dB
3	All emissions, radiated 30MHz-1GHz	± 2.49 dB
4	All emissions, radiated 1GHz-18GHz	± 3.50 dB
5	Occupied bandwidth	± 23.36 Hz
6	Power spectral density	± 0.866 dB

2.8 EQUIPMENTS LIST

2.8.1 Radiation Test equipment

Kind of Equipment	Manufacturer	Type No.	Serial No.	Management number	Calibrated until
Test Receiver	R&S	ESCI	100469	SHATBL-E003	2023.05.20
Spectrum Analyzer	Agilent	N9020A	MY50200811	SHATBL-E017	2023.05.20
Bilog Antenna	SCHWARZBECK	VLUB 9168	01174	SHATBL-E008	2023.05.20
Horn Antenna	SCHWARZBECK	BBHA 9120D	02014	SHATBL-E009	2023.05.20
Pre-Amplifier (0.1M-3GHz)	JPT	JPA-10M1G35	21010100035001	SHATBL-E005	2023.05.20
Pre-Amplifier (1G-18GHz)	JPT	JPA0118-55-303A	1910001800055000	SHATBL-E006	2023.05.20
Temperature & Humidity	DeLi	DeLi	N/A	SHATBL-E016	2023.05.20
Antenna/Turntable Controller	Brilliant	N/A	N/A	SHATBL-E007	N/A
Test SW	FALA	EMC-RI(Ver.4A2)		SHATBL-E046	N/A

2.8.2 Conduction Test equipment

Kind of Equipment	Manufacturer	Type No.	Serial No.	Management number	Calibration date
Test Receiver	R&S	ESPI	101679	SHATBL-E012	2023.05.20
LISN	R&S	ENV216	101300	SHATBL-E013	2023.05.20
LISN	R&S	ENV216	100333	SHATBL-E041	2023.05.20
Temperature & Humidity	DeLi	DeLi	N/A	SHATBL-E015	2023.05.20
Test SW	FALA	EZ-EMC(Ver.EMC-CON3A1.1)		SHATBL-E044	N/A

2.8.3 RF Connected Test

Kind of Equipment	Manufacturer	Type No.	Serial No.	equipment number	Calibrated until
Power meter (with pulse power sensor)	Anritsu	ML2496A	1935001	SHATBL-W030	2023.09.27
Pulse power sensor (with power meter)	Anritsu	MA2411B	1911006	SHATBL-W031	2023.09.27
Signal Analyzer	Agilent	N9020A	MY57300196	SHATBL-W004	2023.09.27
Signal Generator	Agilent	N5182B	MY46240556	SHATBL-W005	2023.09.27
Wireless Communications Test Set	R&S	CMW500	101331	SHATBL-W007	2023.09.27
Temperature & Humidity	Deli	deli	N/A	SHATBL-W011	2023.09.27
Attenuator	Agilent	8494B	DC-18G	SHATBL-W009	2023.09.27
Attenuator	Agilent	8496B	DC-18G	SHATBL-W010	2023.09.27
power splitter	MNK	MPD-DC/6-2 S	62315 G51	SHATBL-W015	2023.09.27
			62315 G52	SHATBL-W016	2023.09.27
Filter	Chengdu kangmaiwei	ZBSF-C2400 -2483.5-T3	N/A	SHATBL-W021	N/A
Constant temperature and humidity box	KSON	THS-B6C-150	6159K	SHATBL-W019	2024.01.16
Test SW	FALA	LZ-RF(Ver.LzRF-03A3.1)		SHATBL-W020	N/A

3. EMC EMISSION TEST

3.1 CONDUCTED EMISSION MEASUREMENT

3.1.1 POWER LINE CONDUCTED EMISSION LIMITS

Operating frequency band. In case the emission fall within the restricted band specified on Part 207(a) limit in the table below has to be followed.

FREQUENCY (MHz)	Conducted Emission limit (dBuV)	
	Quasi-peak	Average
0.15 -0.5	66 - 56 *	56 - 46 *
0.50 -5.0	56.00	46.00
5.0 -30.0	60.00	50.00

Note:

- (1) The tighter limit applies at the band edges.
- (2) The limit of “ * ” marked band means the limitation decreases linearly with the logarithm of the frequency in the range.

The following table is the setting of the receiver

Receiver Parameters	Setting
Attenuation	10dB
Start Frequency	0.15MHz
Stop Frequency	30MHz
IF Bandwidth	9kHz

3.2 TEST PROCEDURE

- a. The EUT is 0.8 m from the horizontal ground plane and 0.4 m from the vertical ground plane with EUT being connected to the power mains through a line impedance stabilization network (LISN). All other support equipment are powered from additional LISN(s). The LISN provides 50 Ohm/ 50uH of coupling impedance for the measuring instrument.
- b. Interconnecting cables that hang closer than 40 cm to the ground plane shall be folded back and forth in the center forming a bundle 30 to 40 cm long.
- c. I/O cables that are not connected to a peripheral shall be bundled in the center. The end of the cable may be terminated, if required, using the correct terminating impedance. The overall length shall not exceed 1 m.
- d. LISN is at least 80 cm from the nearest part of EUT chassis.
- e. For the actual test configuration, please refer to the related Item –EUT Test Photos.

3.3 TEST SETUP

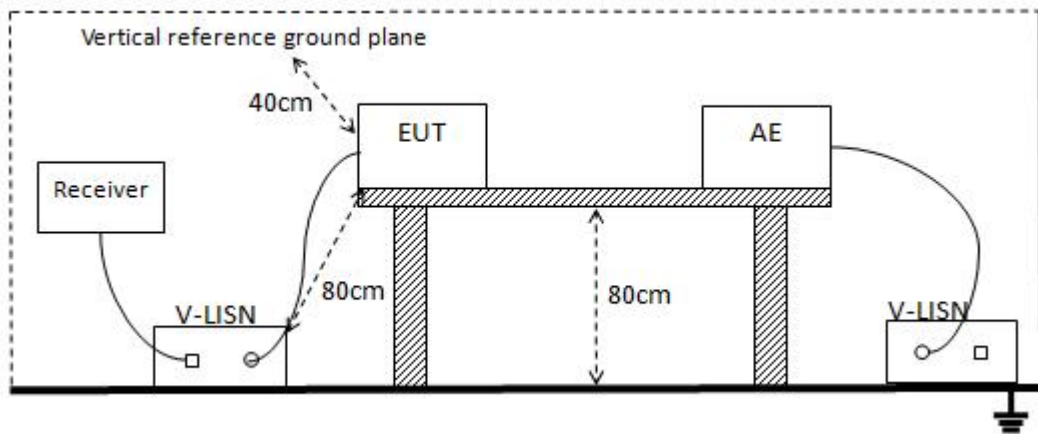

3.4 EUT OPERATING CONDITIONS

The EUT was configured for testing in a typical fashion (as a customer would normally use it). The EUT has been programmed to continuously transmit during test. This operating condition was tested and used to collect the included data.

3.5 TEST RESULTS

Temperature:	23.4°C	Relative Humidity:	55%RH
Test Voltage:	AC 120V/60Hz	Phase:	L
Test Mode:	Mode 4		

No.	Frequency (MHz)	Reading (dBuV)	Correct (dB/m)	Result (dBuV/m)	Limit (dBuV/m)	Margin (dB)	Remark
1	0.2300	34.59	10.74	45.33	62.45	-17.12	QP
2	0.2300	29.08	10.74	39.82	52.45	-12.63	AVG
3	0.5515	34.20	10.67	44.87	56.00	-11.13	QP
4	0.5515	22.99	10.67	33.66	46.00	-12.34	AVG
5	1.7064	29.24	10.77	40.01	56.00	-15.99	QP
6	1.7064	24.73	10.77	35.50	46.00	-10.50	AVG
7	3.6244	23.91	10.81	34.72	56.00	-21.28	QP
8	3.6244	16.58	10.81	27.39	46.00	-18.61	AVG
9	12.6670	15.83	10.74	26.57	60.00	-33.43	QP
10	12.6670	10.60	10.74	21.34	50.00	-28.66	AVG
11	15.6659	16.82	10.85	27.67	60.00	-32.33	QP
12	15.6659	9.71	10.85	20.56	50.00	-29.44	AVG

Remark:

1. All readings are Quasi-Peak and Average values.
2. Margin = Result (Result = Reading + Factor) – Limit.
3. Factor = LISN factor + Cable loss + Limiter (10dB)

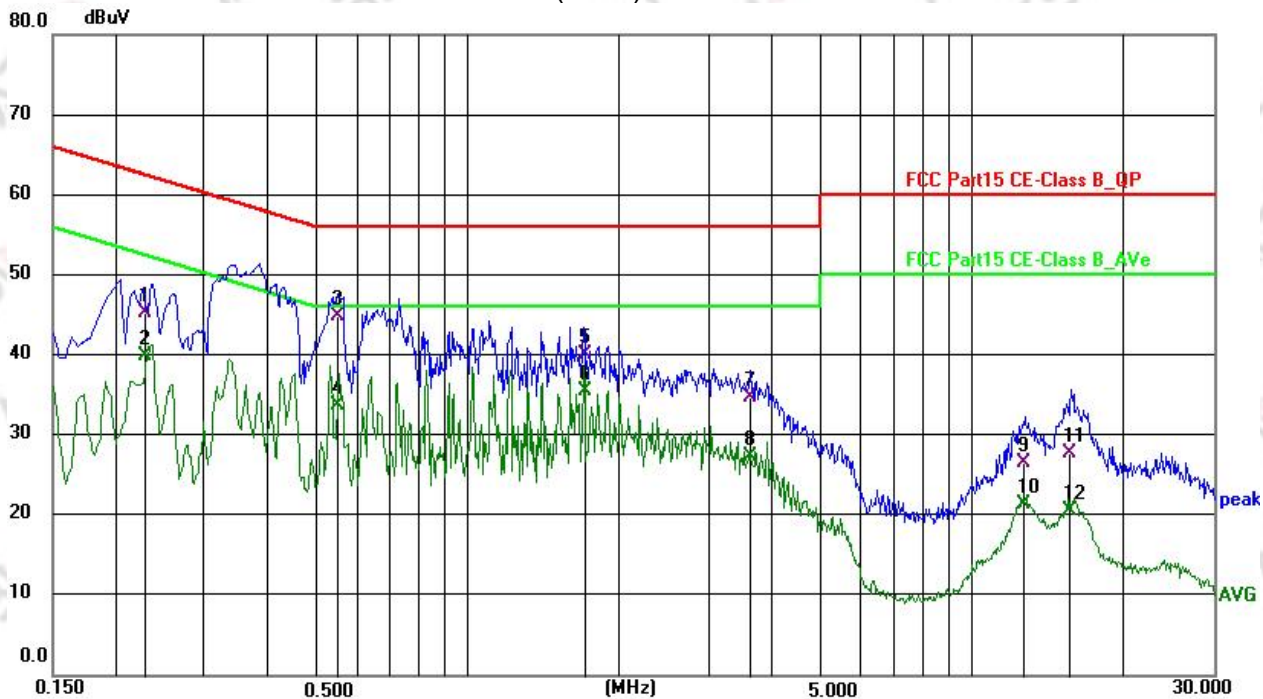

Temperature:	23.4°C	Relative Humidity:	55%RH
Test Voltage:	AC 120V/60Hz	Phase:	N
Test Mode:	Mode 4		

No.	Frequency (MHz)	Reading (dBUV)	Correct (dB/m)	Result (dBUV/m)	Limit (dBUV/m)	Margin (dB)	Remark
1	0.2321	37.33	10.38	47.71	62.37	-14.66	QP
2	0.2321	31.06	10.38	41.44	52.37	-10.93	AVG
3	0.5914	36.65	10.33	46.98	56.00	-9.02	QP
4	0.5914	25.88	10.33	36.21	46.00	-9.79	AVG
5	1.8184	25.47	10.39	35.86	56.00	-20.14	QP
6	1.8184	17.66	10.39	28.05	46.00	-17.95	AVG
7	3.7969	22.58	10.43	33.01	56.00	-22.99	QP
8	3.7969	14.35	10.43	24.78	46.00	-21.22	AVG
9	12.6762	15.97	10.52	26.49	60.00	-33.51	QP
10	12.6762	9.68	10.52	20.20	50.00	-29.80	AVG
11	24.4880	8.63	11.08	19.71	60.00	-40.29	QP
12	24.4880	2.19	11.08	13.27	50.00	-36.73	AVG

Remark:

1. All readings are Quasi-Peak and Average values.
2. Margin = Result (Result = Reading + Factor) – Limit.
3. Factor = LISN factor + Cable loss + Limiter (10dB)

80.0 dBUV

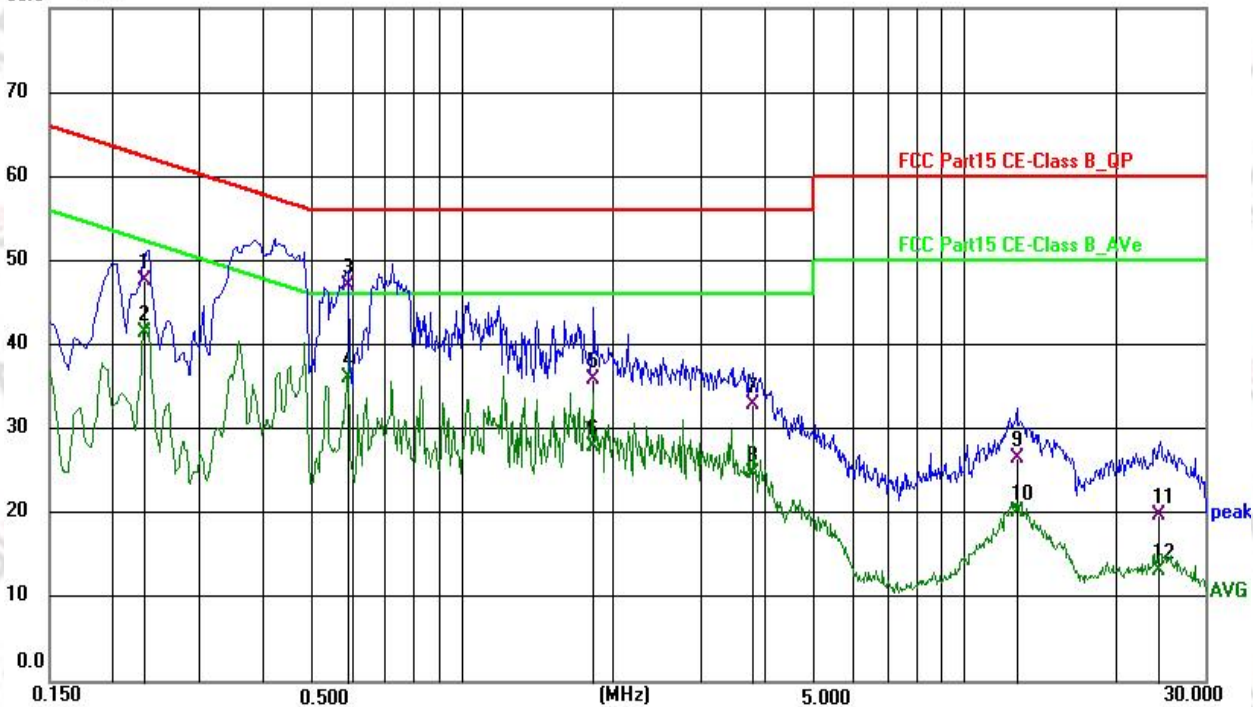

4. RADIATED EMISSION MEASUREMENT

4.1 RADIATED EMISSION LIMITS

In any 100 kHz bandwidth outside the operating frequency band. In case the emission fall within the Restricted band specified on Part15.205(a)&209(a) limit in the table and according to ANSI C63.10-2013 below has to be followed.

LIMITS OF RADIATED EMISSION MEASUREMENT (Frequency Range 9kHz-1000MHz)

Frequencies (MHz)	Field Strength (microrvolts/meter)	Measurement Distance (meters)
0.009~0.490	2400/F(kHz)	300
0.490~1.705	24000/F(kHz)	30
1.705~30.0	30	30
30~88	100	3
88~216	150	3
216~960	200	3
Above 960	500	3

LIMITS OF RADIATED EMISSION MEASUREMENT (Above 1000MHz)

FREQUENCY (MHz)	(dBuV/m) (at 3M)	
	PEAK	AVERAGE
Above 1000	74	54

Notes:

- (1) The limit for radiated test was performed according to FCC PART 15C.
- (2) The tighter limit applies at the band edges.
- (3) Emission level (dBuV/m)=20log Emission level (uV/m).

LIMITS OF RESTRICTED FREQUENCY BANDS

FCC:

FREQUENCY (MHz)	FREQUENCY (MHz)	FREQUENCY (MHz)	FREQUENCY (GHz)
0.090-0.110	16.42-16.423	399.9-410	4.5-5.15
0.495-0.505	16.69475-16.69525	608-614	5.35-5.46
2.1735-2.1905	16.80425-16.80475	960-1240	7.25-7.75
4.125-4.128	25.5-25.67	1300-1427	8.025-8.5
4.17725-4.17775	37.5-38.25	1435-1626.5	9.0-9.2
4.20725-4.20775	73-74.6	1645.5-1646.5	9.3-9.5
6.215-6.218	74.8-75.2	1660-1710	10.6-12.7
6.26775-6.26825	108-121.94	1718.8-1722.2	13.25-13.4
6.31175-6.31225	123-138	2200-2300	14.47-14.5
8.291-8.294	149.9-150.05	2310-2390	15.35-16.2
8.362-8.366	156.52475-156.52525	2483.5-2500	17.7-21.4
8.37625-8.38675	156.7-156.9	2690-2900	22.01-23.12
8.41425-8.41475	162.0125-167.17	3260-3267	23.6-24.0
12.29-12.293	167.72-173.2	3332-3339	31.2-31.8
12.51975-12.52025	240-285	3345.8-3358	36.43-36.5
12.57675-12.57725	322-335.4	3600-4400	Above 38.6
13.36-13.41			

For Radiated Emission

Spectrum Parameter	Setting
Attenuation	Auto
Detector	Peak/QP/AV
Start Frequency	9 kHz/150kHz(Peak/QP/AV)
Stop Frequency	150kHz/30MHz(Peak/QP/AV)
RB / VB (emission in restricted band)	200Hz (From 9kHz to 0.15MHz)/ 9kHz (From 0.15MHz to 30MHz); 200Hz (From 9kHz to 0.15MHz)/ 9kHz (From 0.15MHz to 30MHz)

Spectrum Parameter	Setting
Attenuation	Auto
Detector	Peak/QP
Start Frequency	30 MHz(Peak/QP)
Stop Frequency	1000 MHz (Peak/QP)
RB / VB (emission in restricted band)	120 kHz / 300kHz

Spectrum Parameter	Setting
Attenuation	Auto
Detector	Peak/AV
Start Frequency	1000 MHz(Peak/AV)
Stop Frequency	10th carrier harmonic(Peak/AV)
RB / VB (emission in restricted band)	1 MHz / 3 MHz(Peak) 1 MHz/1/T MHz(AVG)

For Restricted band

Spectrum Parameter	Setting
Detector	Peak/AV
Start/Stop Frequency	2310MHz to 2500MHz
RB / VB	1 MHz / 3 MHz(Peak) 1 MHz/1/T MHz(AVG)

Receiver Parameter	Setting
Start ~ Stop Frequency	9kHz~90kHz / RB 200Hz for PK & AV
Start ~ Stop Frequency	90kHz~110kHz / RB 200Hz for QP
Start ~ Stop Frequency	110kHz~490kHz / RB 200Hz for PK & AV
Start ~ Stop Frequency	490kHz~30MHz / RB 9kHz for QP
Start ~ Stop Frequency	30MHz~1000MHz / RB 120kHz for QP

4.2 TEST PROCEDURE

- a. The measuring distance of at 3 m shall be used for measurements at frequency 0.009MHz up to 1GHz, and above 1GHz.
- b. The EUT was placed on the top of a rotating table 0.8 meters(above 1GHz is 1.5 m) above the ground at a 3 meter an echoic chamber. The table was rotated 360 degrees to determine the position of the highest radiation.
- c. The height of the equipment shall be 0.8 m(above 1GHz is 1.5 m); the height of the test antenna shall vary between 1 m to 4 m. Horizontal and vertical polarization of the antenna are set to make the measurement.
- d. The initial step in collecting conducted emission data is a spectrum analyzer peak detector mode pre-scanning the measurement frequency range. Significant peaks are then marked and then Quasi Peak detector mode re-measured.
- e. If the Peak Mode measured value compliance with and lower than Quasi Peak Mode Limit, the EUT shall be deemed to meet QP Limits and then no additional QP Mode measurement performed.
- f. For the actual test configuration, please refer to the related Item –EUT Test Photos.

Note:

Both horizontal and vertical antenna polarities were tested and performed pretest to three orthogonal axis. The worst case emissions were reported.

4.3 TEST SETUP

(A) Radiated Emission Test-Up Frequency Below 30MHz

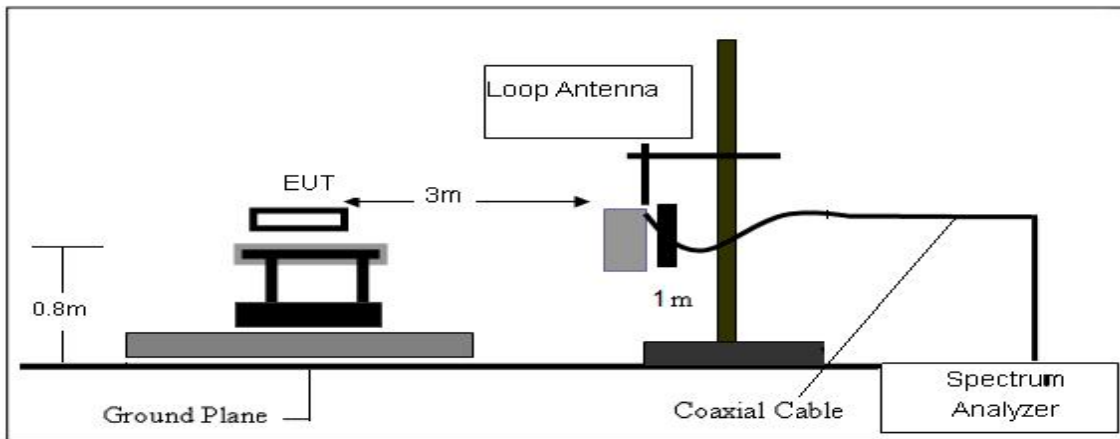

(B) Radiated Emission Test-Up Frequency 30MHz~1GHz

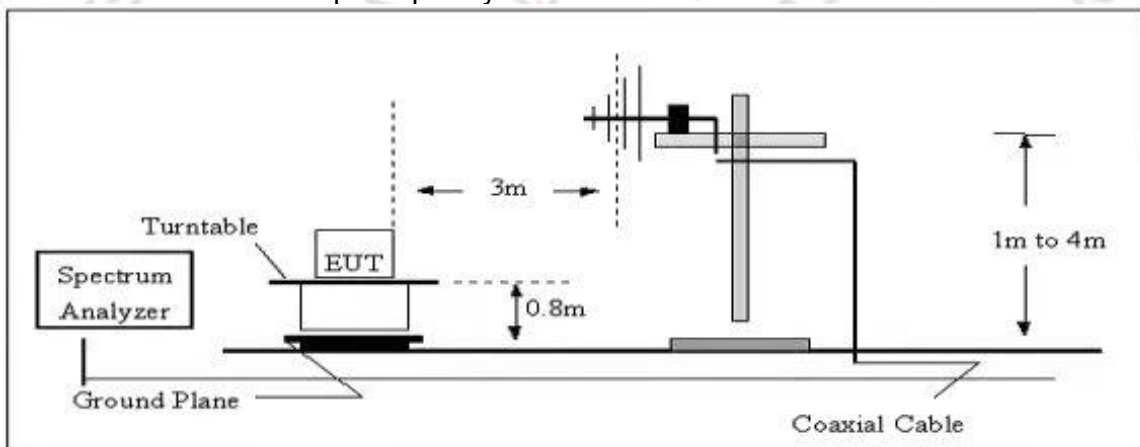

(C) Radiated Emission Test-Up Frequency Above 1GHz

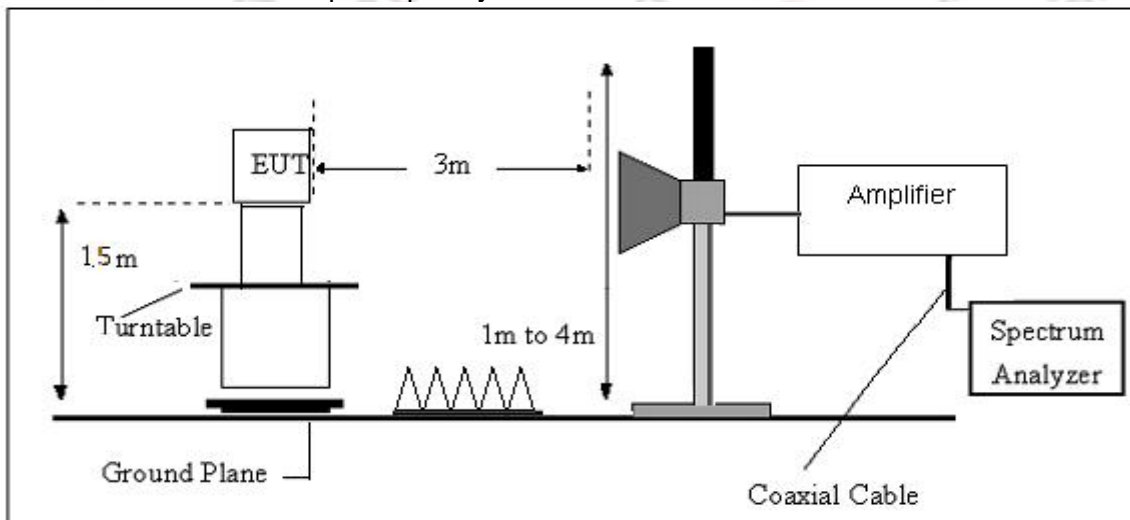

4.4 EUT OPERATING CONDITIONS

The EUT tested system was configured as the statements of 2.3 Unless otherwise a special operating condition is specified in the follows during the testing.

4.5 FIELD STRENGTH CALCULATION

The field strength is calculated by adding the Antenna Factor and Cable Factor and subtracting the Amplifier Gain and Duty Cycle Correction Factor (if any) from the measured reading. The basic equation with a sample calculation is as follows:

$$FS = RA + AF + CL - AG$$

Where

FS = Field Strength

CL = Cable Attenuation Factor (Cable Loss)

RA = Reading Amplitude

AG = Amplifier Gain

AF = Antenna Factor

For example

Frequency (MHz)	FS (dB μ V/m)	RA (dB μ V/m)	AF (dB)	CL (dB)	AG (dB)	Factor (dB)
300	40	58.1	12.2	1.6	31.9	-18.1

$$\text{Factor} = \text{AF} + \text{CL} - \text{AG}$$

4.6 TEST RESULTS

(9kHz -30MHz)

Temperature:	23.4°C	Relative Humidity	55%RH
Test Voltage:	DC5V	Polarization:	
Test Mode:	TX Mode1/2/3		

Note:

The amplitude of spurious emissions which are attenuated by more than 20dB below the permissible value has no need to be reported.

Distance extrapolation factor = $40 \log(\text{specific distance}/\text{test distance})$ (dB);

Limit line = specific limits(dBuv) + distance extrapolation factor.

(30MHz -1000MHz)

Temperature:	23.4°C	Relative Humidity:	55%RH
Test Voltage:	DC 5V	Phase:	H
Test Mode:	TX Mode 1		

Remark:

1. Margin = Result (Result =Reading + Factor)–Limit
2. Factor= Antenna factor+Cable attenuation factor(cable loss)-Amplifier gain

Mode 1 Horizontal

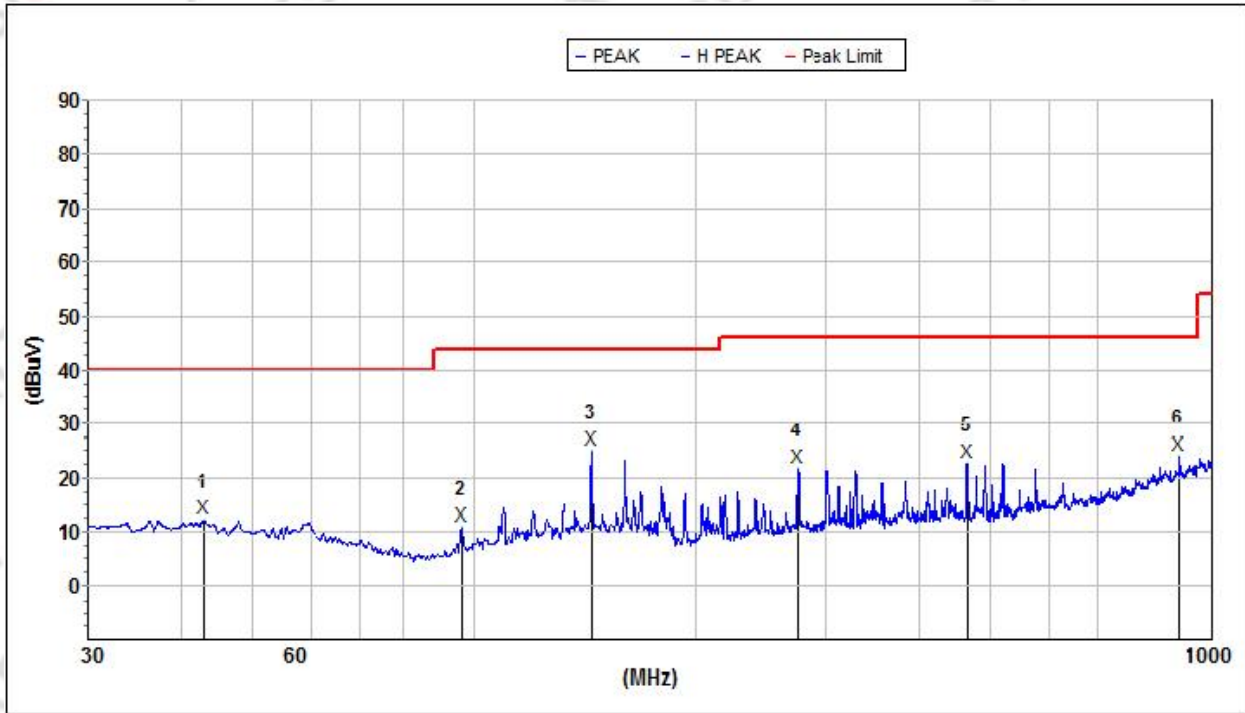

Mk.	Freq. (MHz)	Level (dBuVm)	Limit (dBuV/m)	Margin (dB)	Ant.F/G. (dB/m)	Amp.G. (dB)	Cbl.L. (dB)	Pol.
Peak								
1	43.050457	12.3	40.0	27.7	13.9	32.5	0.8	H
2	96.436153	11.1	43.5	32.4	9.9	32.9	1.3	H
3	144.334759	25.2	43.5	18.3	13.8	32.9	1.3	H
4	273.713554	21.9	46.0	24.1	12.2	32.7	2.6	H
5	466.416465	22.8	46.0	23.2	14.5	32.4	2.8	H
6	898.570586	24.3	46.0	21.7	19.6	31.6	3.6	H

(30MHz -1000MHz)

Temperature:	23.4°C	Relative Humidity:	55%RH
Test Voltage:	DC 5V	Phase:	Vertical
Test Mode:	TX Mode 1		

Remark:

1. Margin = Result (Result =Reading + Factor)–Limit
2. Factor= Antenna factor+Cable attenuation factor(cable loss)-Amplifier gain

Mode 1 Vertical

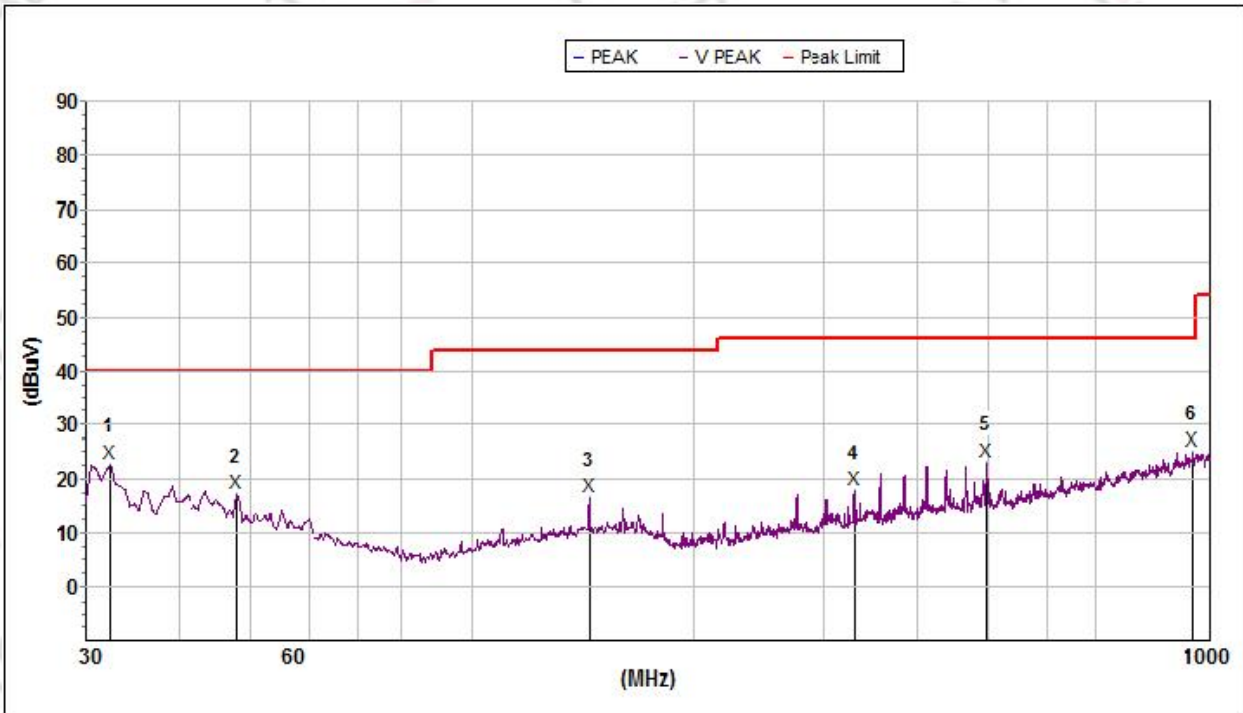

Mk.	Freq.(MHz)	Level (dBuV/m)	Limit (dBuV/m)	Margin (dB)	Ant.F/G. (dB/m)	Amp.G. (dB)	Cbl.L. (dB)	Pol.
Peak								
1	32.405937	22.8	40.0	17.2	13.3	32.2	0.8	V
2	47.909933	17.3	40.0	22.7	13.7	32.6	0.8	V
3	144.334759	16.6	43.5	26.9	13.8	32.9	1.3	V
4	330.194866	17.8	46.0	28.2	13.4	32.6	2.7	V
5	496.804694	23.2	46.0	22.8	16.5	32.5	2.8	V
6	948.760988	25.3	46.0	20.7	22.1	31.3	3.7	V

(30MHz -1000MHz)

Temperature:	23.4°C	Relative Humidity:	55%RH
Test Voltage:	DC 5V	Phase:	Horizontal
Test Mode:	TX Mode 3		

Remark:

1. Margin = Result (Result =Reading + Factor)-Limit
2. Factor= Antenna factor+Cable attenuation factor(cable loss)-Amplifier gain

Mode 3 Horizontal

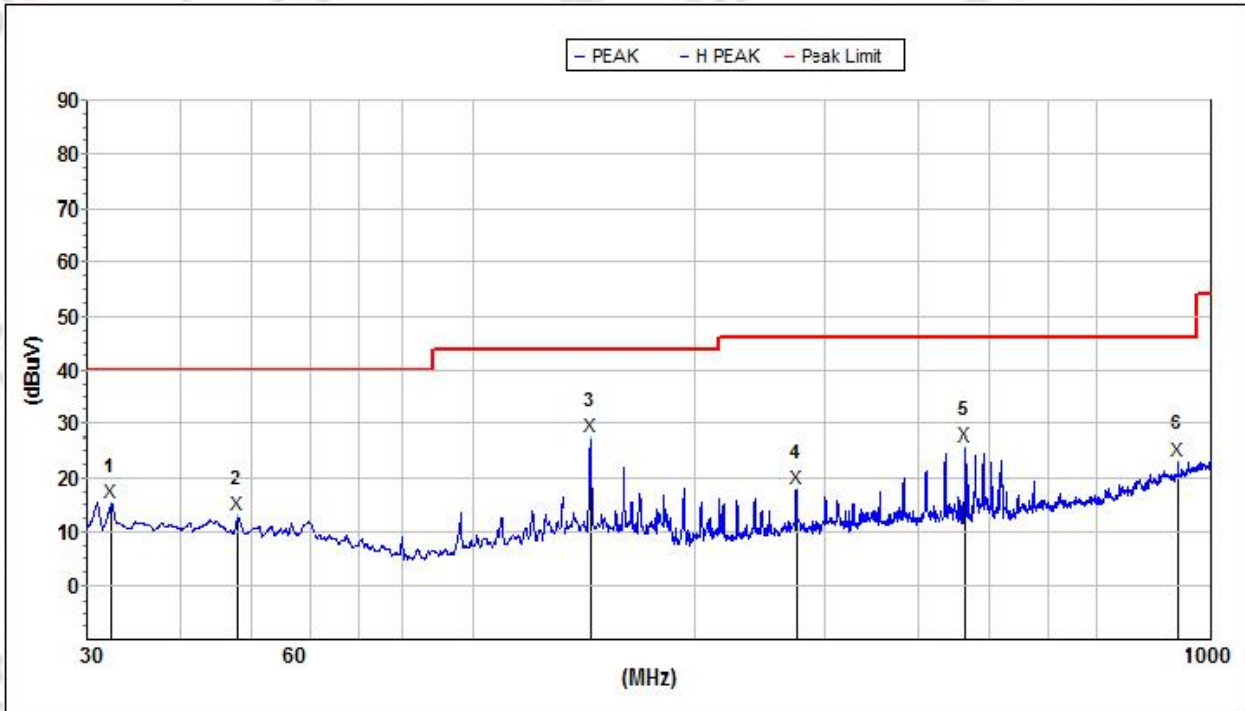

Mk.	Freq. (MHz)	Level (dBUV/m)	Limit (dBUV/m)	Margin (dB)	Ant.F/G. (dB/m)	Amp.G. (dB)	Cbl.L. (dB)	Pol.
Peak								
1	32.405937	15.4	40.0	24.6	13.3	32.2	0.8	H
2	47.909933	13.1	40.0	26.9	13.7	32.6	0.8	H
3	144.334759	27.6	43.5	15.9	13.8	32.9	1.3	H
4	273.234078	18.1	46.0	27.9	12.2	32.7	2.6	H
5	464.783813	25.9	46.0	20.1	14.4	32.4	2.8	H
6	898.570586	23.3	46.0	22.7	19.6	31.6	3.6	H

(30MHz -1000MHz)

Temperature:	23.4°C	Relative Humidity:	55%RH
Test Voltage:	DC 5V	Phase:	Vertical
Test Mode:	TX Mode 3		

Remark:

- Margin = Result (Result =Reading + Factor)-Limit
- Factor= Antenna factor+Cable attenuation factor(cable loss)-Amplifier gain

Mode 3 Vertical

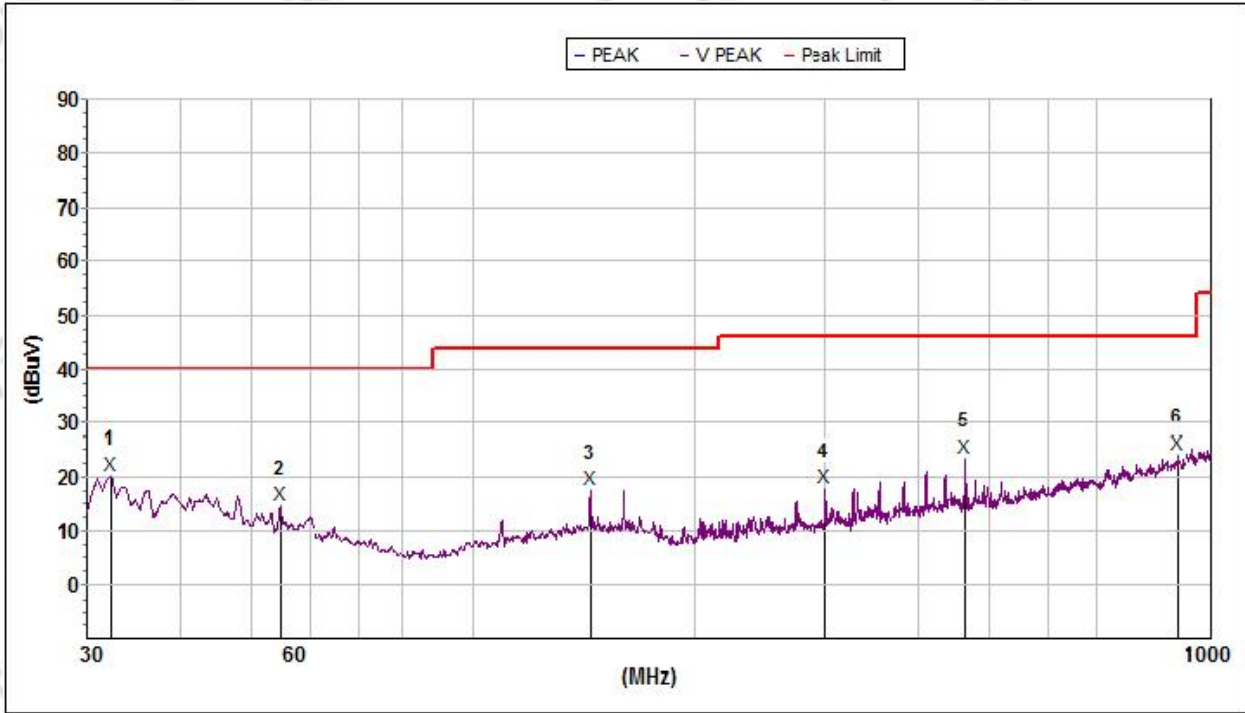

Mk.	Freq. (MHz)	Level (dBuV/m)	Limit (dBuV/m)	Margin (dB)	Ant.F/G. (dB/m)	Amp.G. (dB)	Cbl.L. (dB)	Pol.
Peak								
1	32.405937	20.1	40.0	19.9	13.3	32.2	0.8	V
2	54.642872	14.6	40.0	25.4	13.2	32.7	0.8	V
3	144.334759	17.7	43.5	25.8	13.8	32.9	1.3	V
4	299.841092	17.8	46.0	28.2	12.8	32.7	2.7	V
5	463.969631	23.6	46.0	22.4	16.1	32.4	2.8	V
6	898.570586	24.1	46.0	21.9	21.6	31.6	3.6	V

(1000MHz -18000MHz)

Temperature:	23.4°C	Relative Humidity:	55%RH
Test Voltage:	DC 5V	Phase:	Horizontal
Test Mode:	TX Mode 1		

Remark:

1. Margin = Result (Result =Reading + Factor)-Limit
2. Factor= Antenna factor+Cable attenuation factor(cable loss)-Amplifier gain

Mode 1 Horizontal

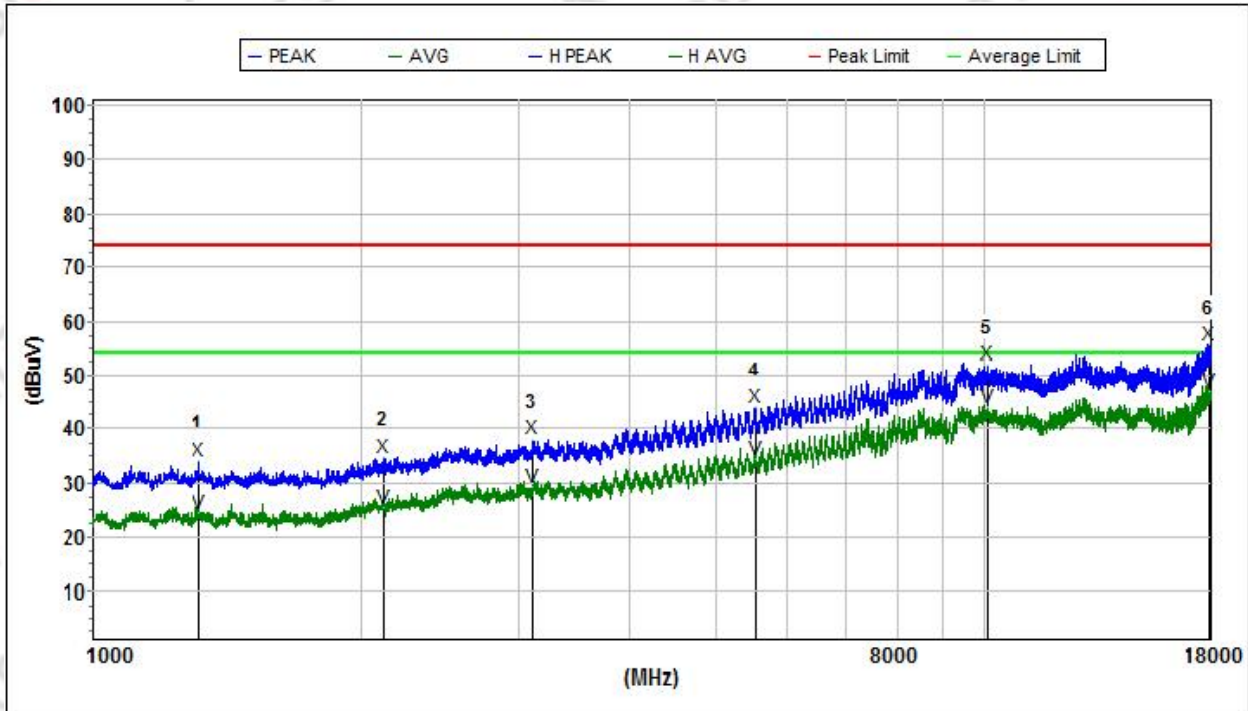

Mk.	Freq. (MHz)	Level (dBuV/m)	Limit (dBuV/m)	Margin (dB)	Ant.F/G. (dB/m)	Amp.G. (dB)	Cbl.L. (dB)	Pol.
Peak:								
1	1312.800000	34.1	74.0	39.9	25.8	61.1	2.3	H
2	2113.500000	34.9	74.0	39.1	27.2	60.8	2.7	H
3	3113.950000	38.2	74.0	35.8	29.7	58.7	3.0	H
4	5539.850000	44.0	74.0	30.0	32.8	58.1	4.0	H
5	10112.000000	52.0	74.0	22.0	38.6	60.4	5.4	H
6	17885.250000	55.6	74.0	18.4	41.6	57.7	7.0	H
Avg								
1	1312.800000	24.2	54.0	29.8	25.8	61.1	2.3	H
2	2113.500000	25.5	54.0	28.5	27.2	60.8	2.7	H
3	3113.950000	29.4	54.0	24.6	29.7	58.7	3.0	H
4	5539.850000	34.5	54.0	19.5	32.8	58.1	4.0	H
5	10112.000000	44.0	54.0	10.0	38.6	60.4	5.4	H
6	17885.250000	46.9	54.0	7.1	41.6	57.7	7.0	H

(1000MHz -18000MHz)

Temperature:	23.4°C	Relative Humidity:	55%RH
Test Voltage:	DC 5V	Phase:	Vertical
Test Mode:	TX Mode 1		

Remark:

- Margin = Result (Result =Reading + Factor)–Limit
- Factor= Antenna factor+Cable attenuation factor(cable loss)-Amplifier gain

Mode 1 Vertical

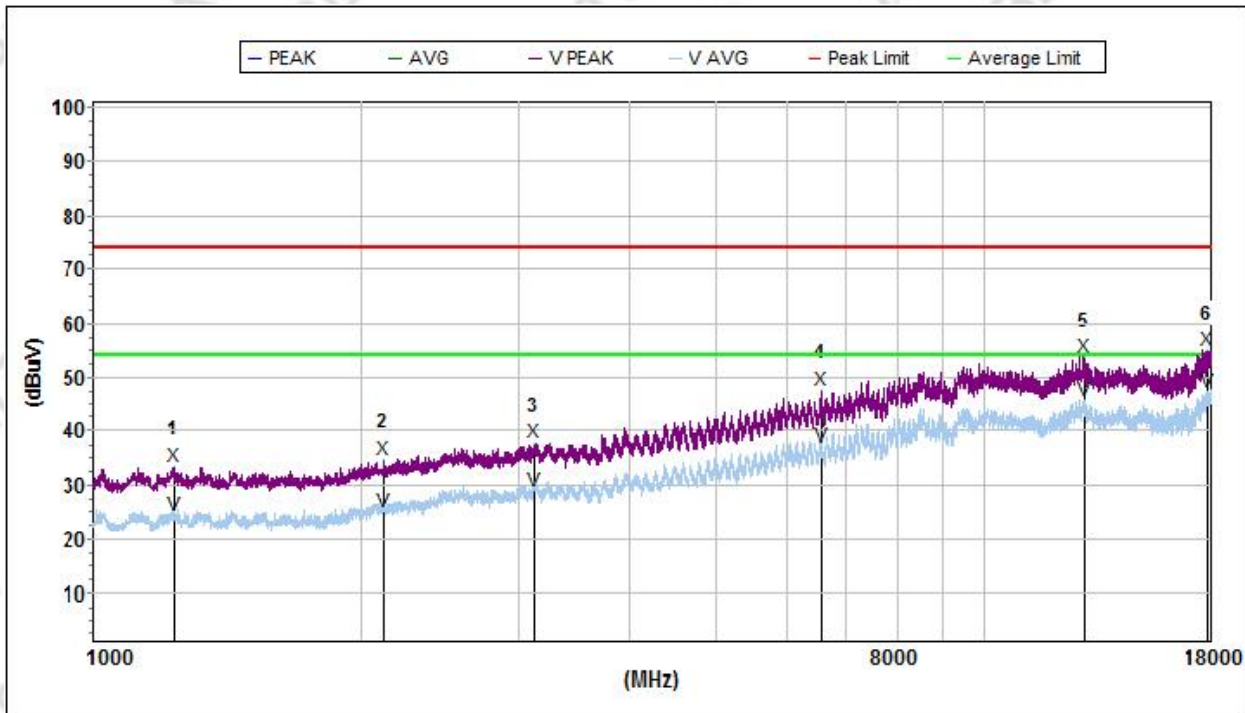

Mk.	Freq. (MHz)	Level (dBuV/m)	Limit (dBuV/m)	Margin (dB)	Ant.F/G. (dB/m)	Amp.G. (dB)	Cbl.L. (dB)	Pol.
Peak								
1	1228.650000	33.7	74.0	40.3	25.8	60.9	2.3	V
2	2120.300000	34.8	74.0	39.2	27.2	60.8	2.7	V
3	3122.450000	38.0	74.0	36.0	29.7	58.7	3.0	V
4	6567.500000	47.7	74.0	26.3	35.3	58.1	4.2	V
5	13002.850000	53.7	74.0	20.3	39.8	57.7	6.2	V
6	17809.600000	54.9	74.0	19.1	41.2	57.8	7.0	V
Avg								
1	1228.650000	24.5	54.0	29.5	25.8	60.9	2.3	V
2	2120.300000	25.0	54.0	29.0	27.2	60.8	2.7	V
3	3122.450000	28.9	54.0	25.1	29.7	58.7	3.0	V
4	6567.500000	37.1	54.0	16.9	35.3	58.1	4.2	V
5	13002.850000	45.6	54.0	8.4	39.8	57.7	6.2	V
6	17809.600000	47.4	54.0	6.6	41.2	57.8	7.0	V

(1000MHz -18000MHz)

Temperature:	23.4°C	Relative Humidity:	55%RH
Test Voltage:	DC 5V	Phase:	Horizontal
Test Mode:	TX Mode 3		

Remark:

- Margin = Result (Result =Reading + Factor)–Limit
- Factor= Antenna factor+Cable attenuation factor(cable loss)-Amplifier gain
Mode 3 Horizontal

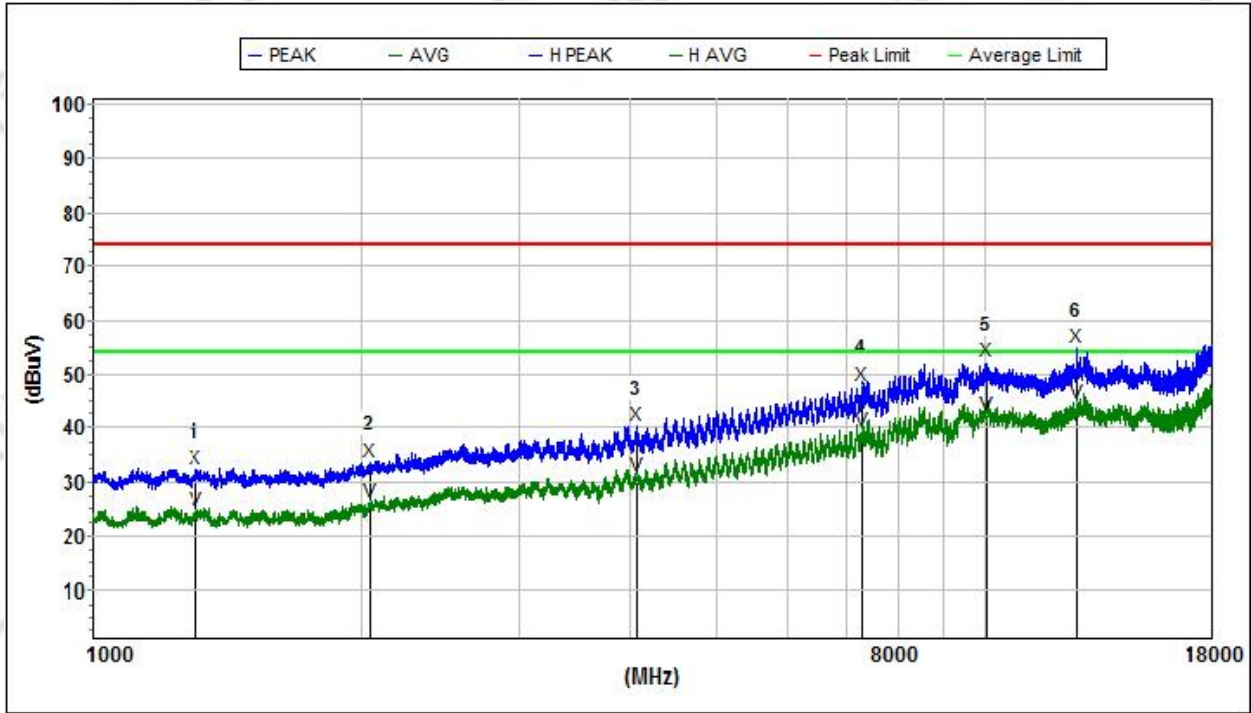

Mk.	Freq. (MHz)	Level (dBuV/m)	Limit (dBuV/m)	Margin (dB)	Ant.F/G. (dB/m)	Amp.G. (dB)	Cbl.L. (dB)	Pol.
Peak:								
1	1303.450000	32.5	74.0	41.5	25.8	61.1	2.3	H
2	2041.250000	34.0	74.0	40.0	26.8	60.9	2.7	H
3	4065.950000	40.6	74.0	33.4	30.8	58.3	3.3	H
4	7284.900000	48.2	74.0	25.8	36.8	57.6	4.5	H
5	10066.100000	52.3	74.0	21.7	38.6	60.3	5.4	H
6	12707.050000	55.0	74.0	19.0	39.4	58.0	6.1	H
Avg								
1	1303.450000	24.7	54.0	29.3	25.8	61.1	2.3	H
2	2041.250000	26.2	54.0	27.8	26.8	60.9	2.7	H
3	4065.950000	31.2	54.0	22.8	30.8	58.3	3.3	H
4	7284.900000	39.4	54.0	14.6	36.8	57.6	4.5	H
5	10066.100000	42.6	54.0	11.4	38.6	60.3	5.4	H
6	12707.050000	44.7	54.0	9.3	39.4	58.0	6.1	H

(1000MHz -18000MHz)

Temperature:	25.3°C	Relative Humidity:	52%RH
Test Voltage:	DC 5V	Phase:	Vertical
Test Mode:	TX Mode 3		

Remark:

1. Margin = Result (Result =Reading + Factor)–Limit
2. Factor= Antenna factor+Cable attenuation factor(cable loss)-Amplifier gain
Mode 3 Vertical

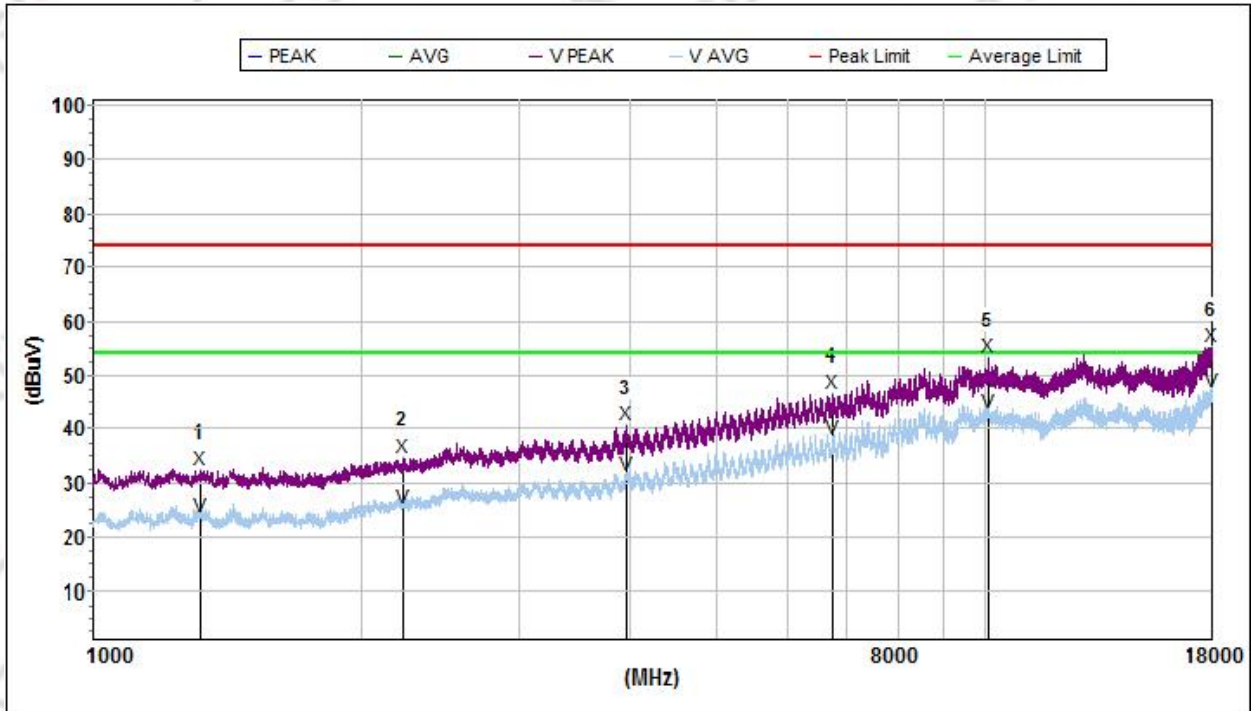

Mk.	Freq. (MHz)	Level (dBuV/m)	Limit (dBuV/m)	Margin (dB)	Ant.F/G. (dB/m)	Amp.G. (dB)	Cbl.L. (dB)	Pol.
Peak:								
1	1323.000000	32.6	74.0	41.4	25.8	61.1	2.3	V
2	2224.000000	34.8	74.0	39.2	27.2	60.4	2.8	V
3	3959.700000	40.9	74.0	33.1	30.8	58.5	3.3	V
4	6772.350000	46.6	74.0	27.4	35.8	58.4	4.3	V
5	10080.550000	53.4	74.0	20.6	38.6	60.4	5.4	V
6	17997.450000	55.2	74.0	18.8	42.3	57.6	7.0	V
Avg								
1	1323.000000	23.8	54.0	30.2	25.8	61.1	2.3	V
2	2224.000000	25.5	54.0	28.5	27.2	60.4	2.8	V
3	3959.700000	31.7	54.0	22.3	30.8	58.5	3.3	V
4	6772.350000	38.1	54.0	15.9	35.8	58.4	4.3	V
5	10080.550000	43.2	54.0	10.8	38.6	60.4	5.4	V
6	17997.450000	47.2	54.0	6.8	42.3	57.6	7.0	V

Note:

- 1.All TX Mode, the worst case is mode1&3, only show the worst case.
- 2.Other 18G-25G Emission detected are more than 20dB below the limit.

4.6 TEST RESULTS (Restricted Bands Requirements)

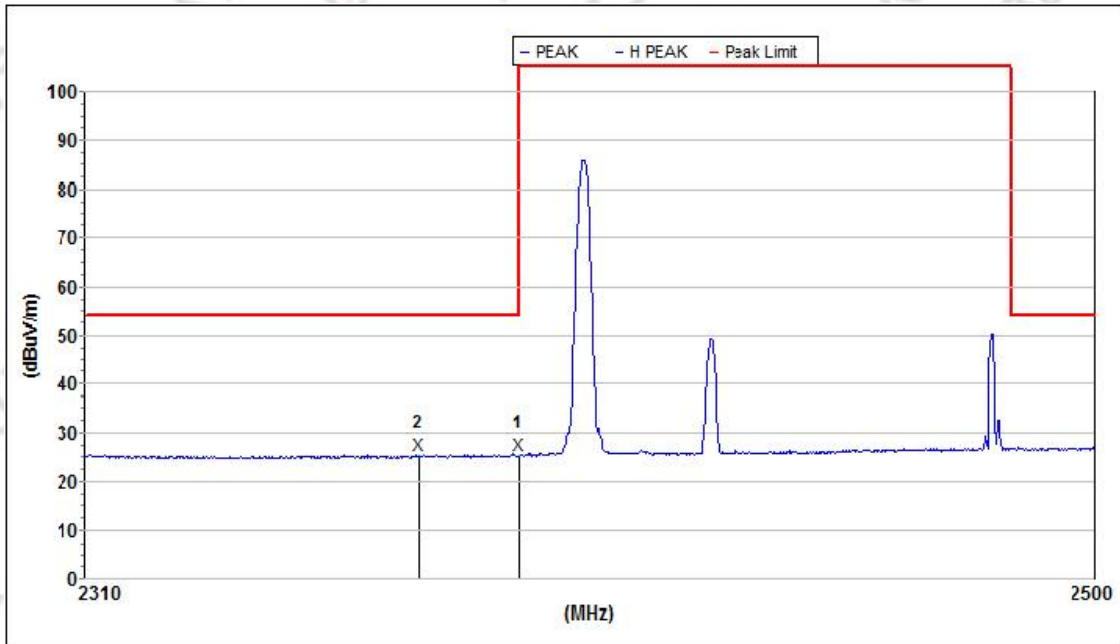
GFSK-Low
 Mode 1 Horizontal

Mk.	Frequency (MHz)	Level (dBuV/m)	Limit (dBuV/m)	Margin (dB)	Ant.F/G. (dB/m)	Amp.G. (dB)	Cbl.L. (dB)	Pol.
Avg								
1	2390.000000	25.4	54.0	28.6	27.3	59.6	2.8	H
2	2371.234786	25.4	54.0	28.6	27.3	59.6	2.8	H

Mode 1 Vertical

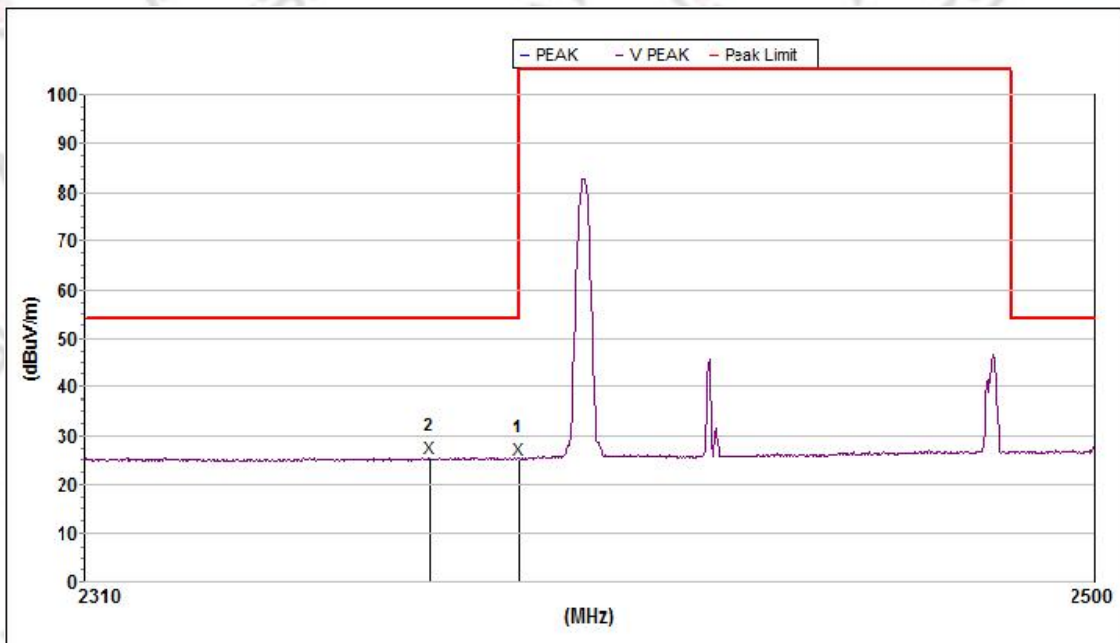

Mk.	Frequency (MHz)	Level (dBuV/m)	Limit (dBuV/m)	Margin (dB)	Ant.F/G. (dB/m)	Amp.G. (dB)	Cbl.L. (dB)	Pol.
Avg								
1	2390.000000	25.1	54.0	28.9	27.3	59.6	2.8	V
2	2373.297412	25.4	54.0	28.6	27.3	59.6	2.8	V

GFSK-Low
Mode 1 Horizontal

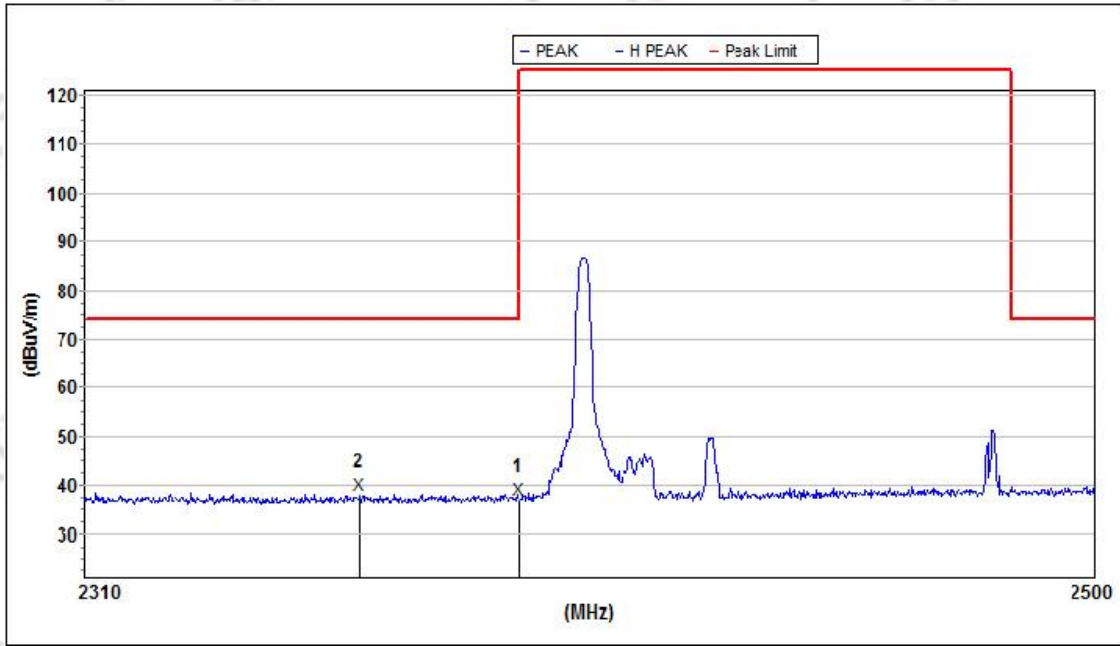

Mk.	Frequency (MHz)	Level (dBuV/m)	Limit (dBuV/m)	Margin (dB)	Ant.F/G. (dB/m)	Amp.G. (dB)	Cbl.L. (dB)	Pol.
Peak:								
1	2390.000000	37.0	74.0	37.0	27.3	59.6	2.8	H
2	2360.202161	38.2	74.0	35.8	27.3	59.7	2.8	H

Mode 1 Vertical

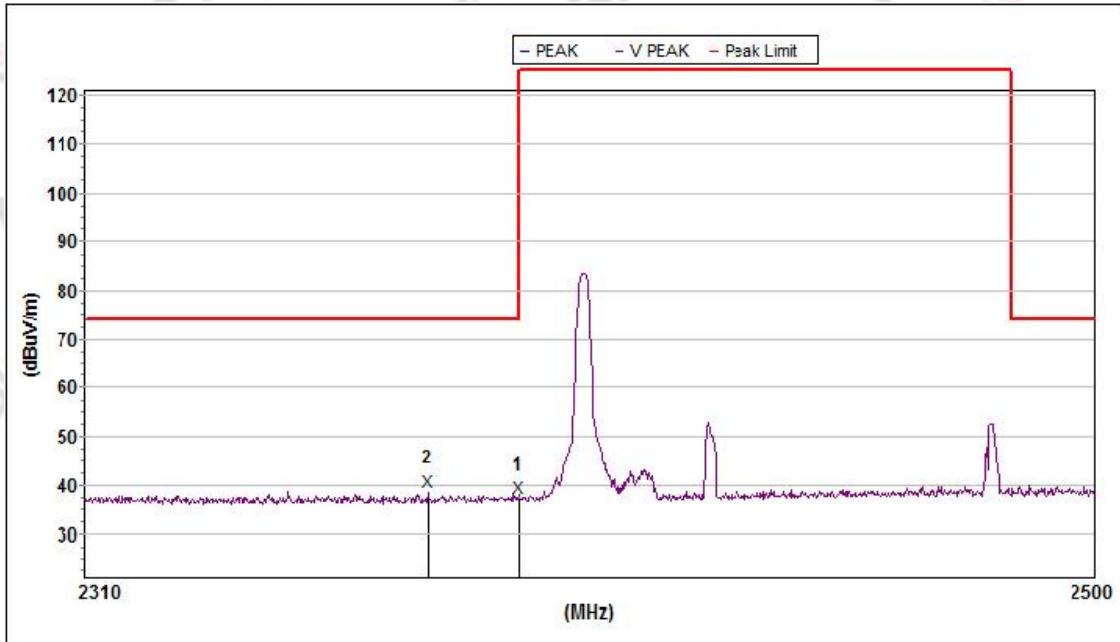

Mk.	Frequency (MHz)	Level (dBuV/m)	Limit (dBuV/m)	Margin (dB)	Ant.F/G. (dB/m)	Amp.G. (dB)	Cbl.L. (dB)	Pol.
Peak:								
1	2390.000000	37.3	74.0	36.7	27.3	59.6	2.8	V
2	2372.922256	38.6	74.0	35.4	27.3	59.6	2.8	V

GFSK-High
Mode 3 Horizontal

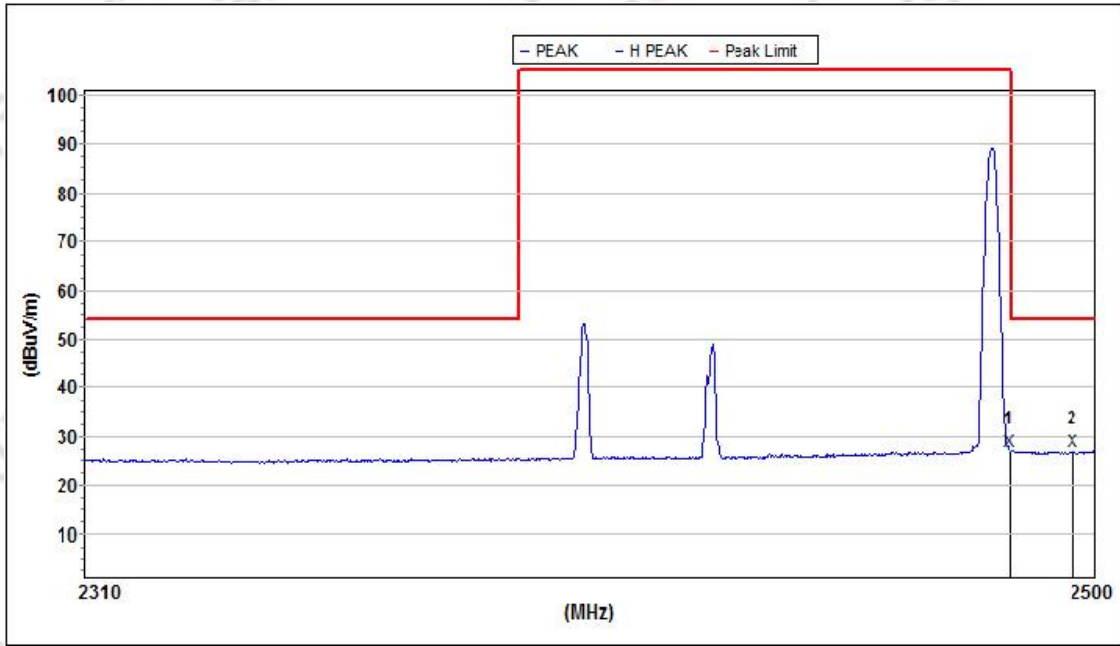

Mk.	Frequency (MHz)	Level (dBuV/m)	Limit (dBuV/m)	Margin (dB)	Ant.F/G. (dB/m)	Amp.G. (dB)	Cbl.L. (dB)	Pol.
Avg								
1	2483.501000	27.1	54.0	26.9	27.7	58.9	2.8	H
2	2495.853674	26.9	54.0	27.1	27.7	58.8	2.8	H

Mode 3 Vertical

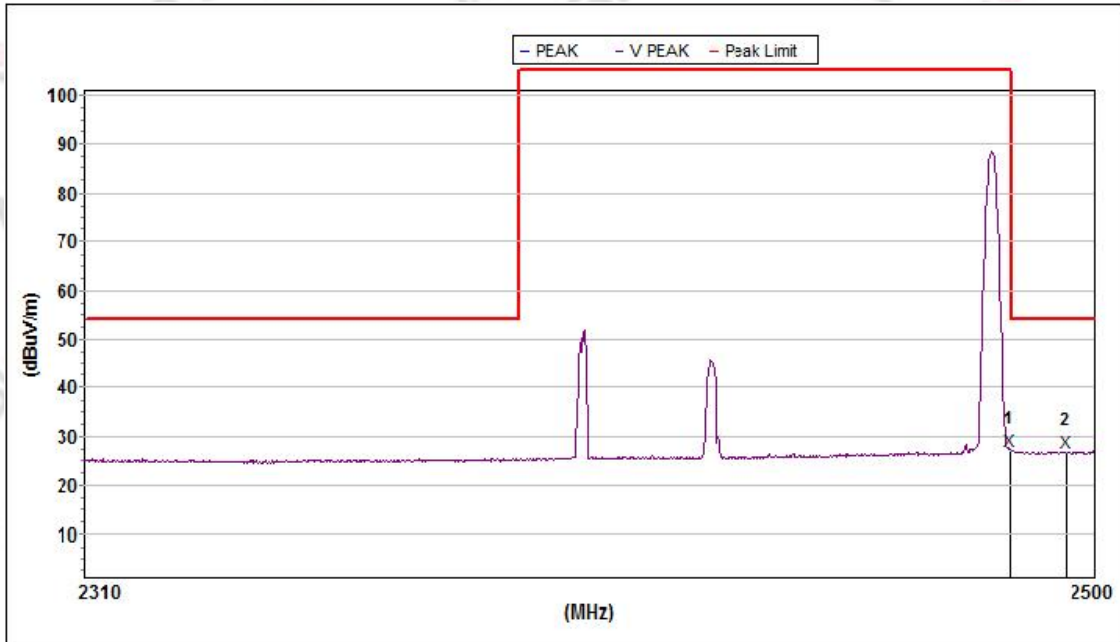

Mk.	Frequency (MHz)	Level (dBuV/m)	Limit (dBuV/m)	Margin (dB)	Ant.F/G. (dB/m)	Amp.G. (dB)	Cbl.L. (dB)	Pol.
Avg								
1	2483.501000	26.9	54.0	27.1	27.7	58.9	2.8	V
2	2494.275930	26.7	54.0	27.3	27.7	58.8	2.8	V

GFSK- High
Mode 3 Horizontal

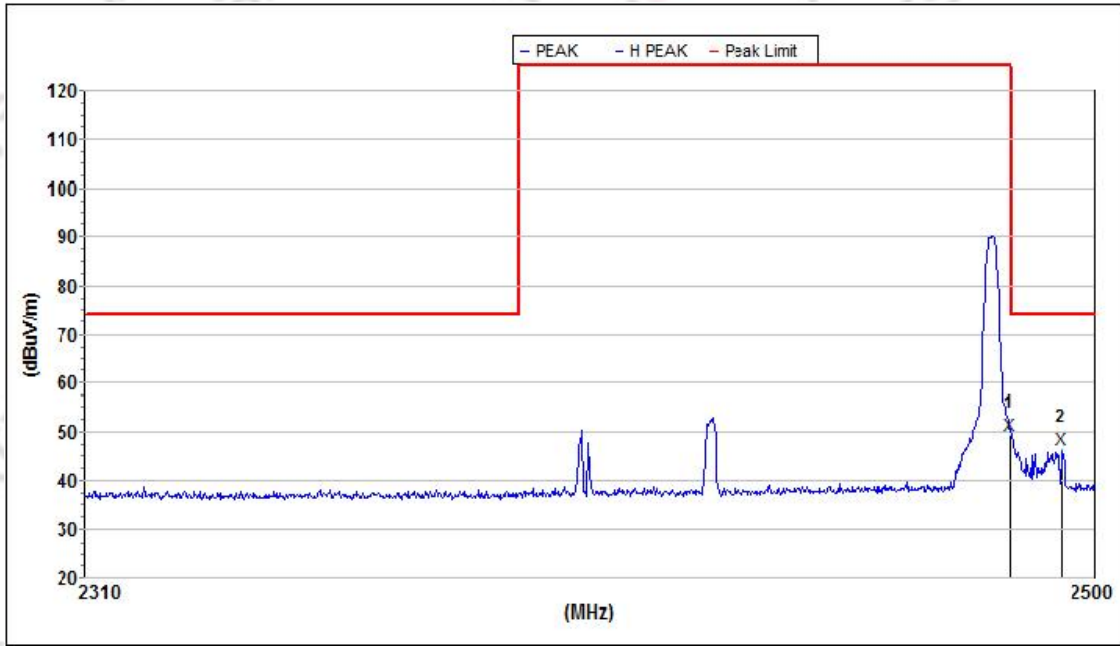

Mk.	Frequency (MHz)	Level (dBuV/m)	Limit (dBuV/m)	Margin (dB)	Ant.F/G. (dB/m)	Amp.G. (dB)	Cbl.L. (dB)	Pol.
Peak:								
1	2483.501000	49.4	74.0	24.6	27.7	58.9	2.8	H
2	2493.487433	46.2	74.0	27.8	27.7	58.8	2.8	H

Mode 3 Vertical

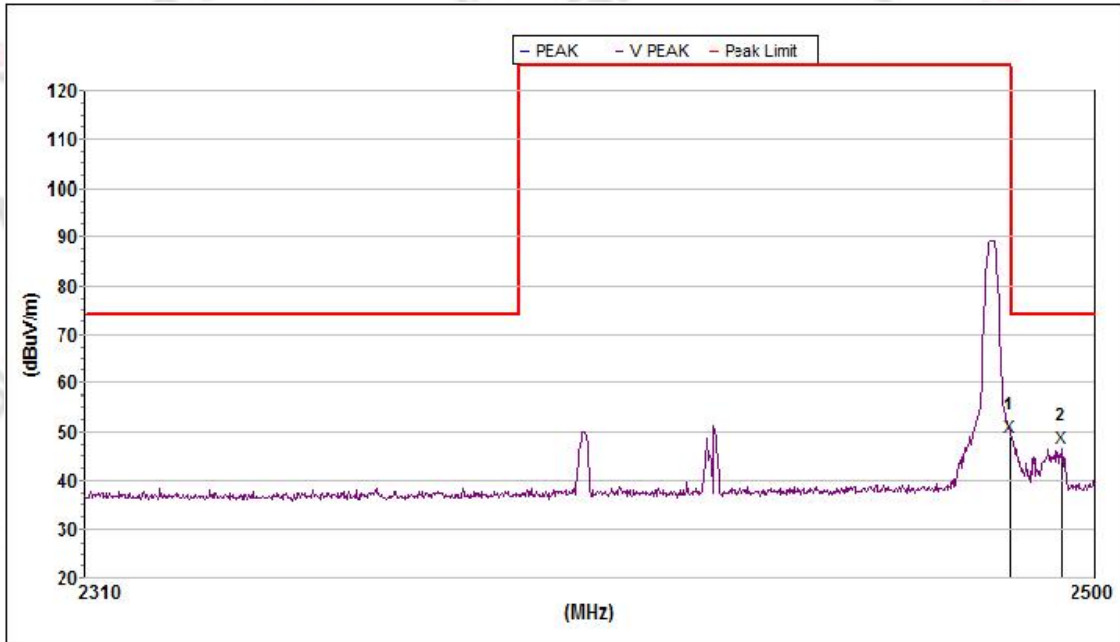

Mk.	Frequency (MHz)	Level (dBuV/m)	Limit (dBuV/m)	Margin (dB)	Ant.F/G. (dB/m)	Amp.G. (dB)	Cbl.L. (dB)	Pol.
Peak:								
1	2483.501000	48.9	74.0	25.1	27.7	58.9	2.8	V
2	2493.487433	46.8	74.0	27.2	27.7	58.8	2.8	V

Note: All TX Mode, the worst case is mode1&3, only show the worst case.

5. CONDUCTED SPURIOUS & BAND EDGE EMISSION

5.1 LIMIT

In any 100kHz bandwidth outside the frequency band in which the spread spectrum or digitally modulated intentional radiator is operating, the radio frequency power that is produced by the intentional radiator shall be at least 20dB below that in the 100kHz bandwidth within the band that contains the highest level of the desired power, based on either an RF conducted or a radiated measurement.

5.2 TEST PROCEDURE

Spectrum Parameter	Setting
Detector	Peak
Start/Stop Frequency	30 MHz to 10th carrier harmonic
RB / VB (emission in restricted band)	100 kHz/300 kHz
Trace-Mode:	Max hold

For Band edge

Spectrum Parameter	Setting
Detector	Peak
Start/Stop Frequency	Lower Band Edge: 2300 – 2450 MHz Upper Band Edge: 2430 – 2580 MHz
RB / VB (emission in restricted band)	100 kHz/300 kHz
Trace-Mode:	Max hold

5.3 TEST SETUP



The EUT which is powered by the Battery, is connected to the Spectrum Analyzer; the RF load attached to the EUT antenna terminal is 50 Ohm; the path loss as the factor is calibrated to correct the reading. Make the measurement with the spectrum analyzer's resolution bandwidth (RBW) = 100 kHz. In order to make an accurate measurement, set the span greater than RBW.

5.4 EUT OPERATION CONDITIONS

The EUT tested system was configured as the statements of 2.3 Unless otherwise a special operating condition is specified in the follows during the testing.

5.5 TEST RESULTS

Temperature:	23.4 °C	Relative Humidity:	55%RH
Test Voltage:	DC 5V	Test Mode:	TX Mode 1/2/3

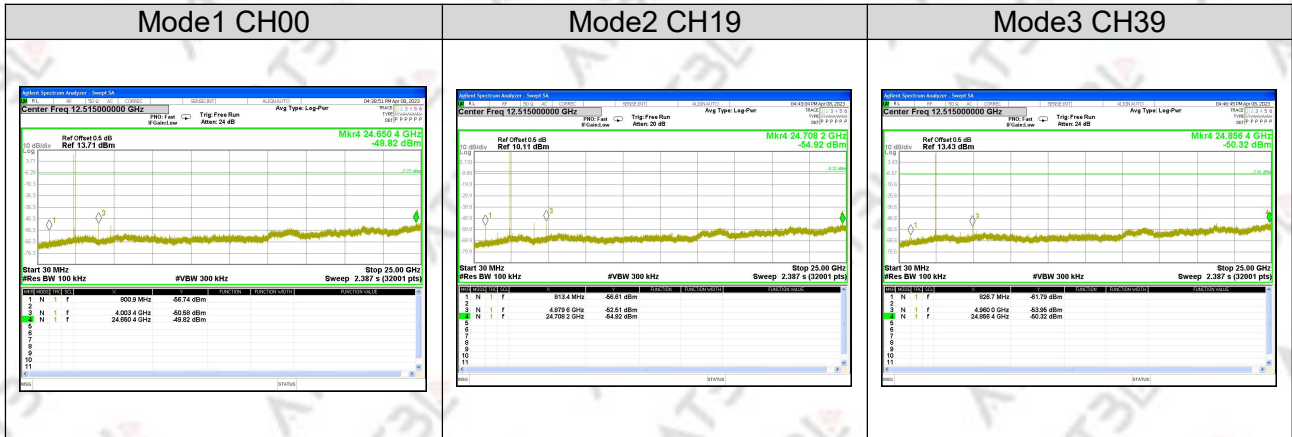

For Band edge(it's also the reference level for conducted spurious emission)

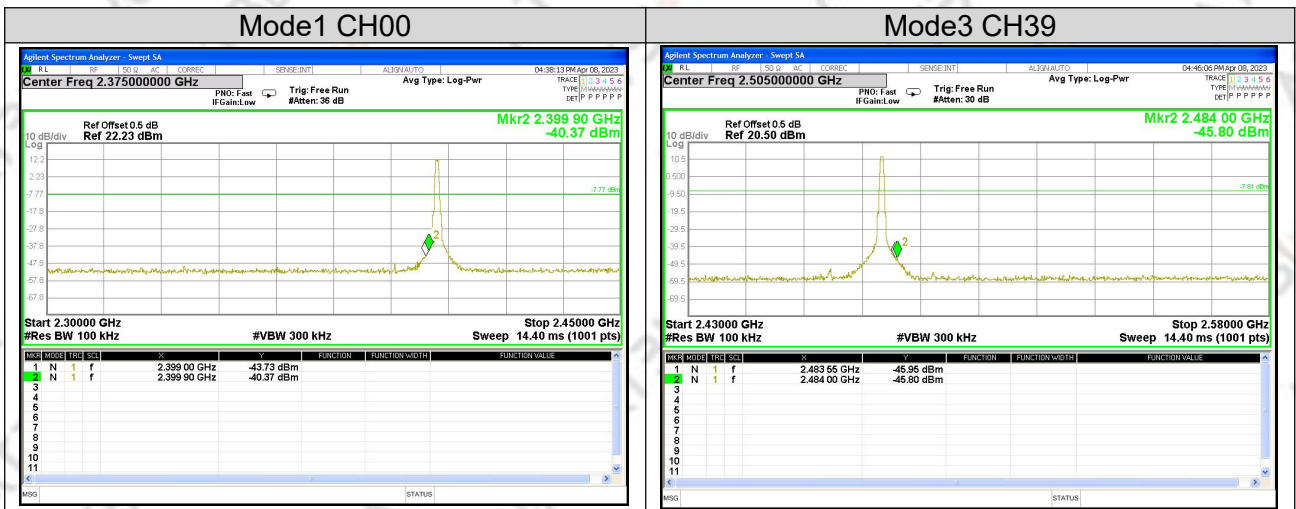

6. POWER SPECTRAL DENSITY TEST

6.1 LIMIT

FCC Part 15.247, Subpart C				
Section	Test Item	Limit	Frequency Range (MHz)	Result
15.247(e)	Power Spectral Density	$\leq 8\text{dBm}$ ($\text{RBW} \geq 3\text{kHz}$)	2400-2483.5	PASS

6.2 TEST PROCEDURE

1. Set analyzer center frequency to DTS channel center frequency.
2. Set the span to 1.5 times the DTS channel bandwidth.
3. Set the RBW to: $100\text{ kHz} \geq \text{RBW} \geq 3\text{ kHz}$.
4. Set the VBW $\geq 3 \times \text{RBW}$.
5. Detector = peak.
6. Sweep time = auto couple.
7. Trace mode = max hold.
8. Allow trace to fully stabilize.
9. Use the peak marker function to determine the maximum amplitude level.
10. If measured value exceeds limit, reduce RBW (no less than 3 kHz) and repeat.

6.3 TEST SETUP



6.4 EUT OPERATION CONDITIONS

The EUT tested system was configured as the statements of 2.3 Unless otherwise a special operating condition is specified in the follows during the testing.

6.5 TEST RESULTS

Temperature:	23.4 °C	Relative Humidity:	55%RH
Test Voltage:	DC 5V	Test Mode:	TX Mode1/2/3

	Frequency	Power Density	Limit (3kHz/dBm)	Result
		(dBm/3kHz)		
1M bps	2402 MHz	-2.26	≤8	PASS
	2440 MHz	-2.51	≤8	PASS
	2480 MHz	-2.13	≤8	PASS

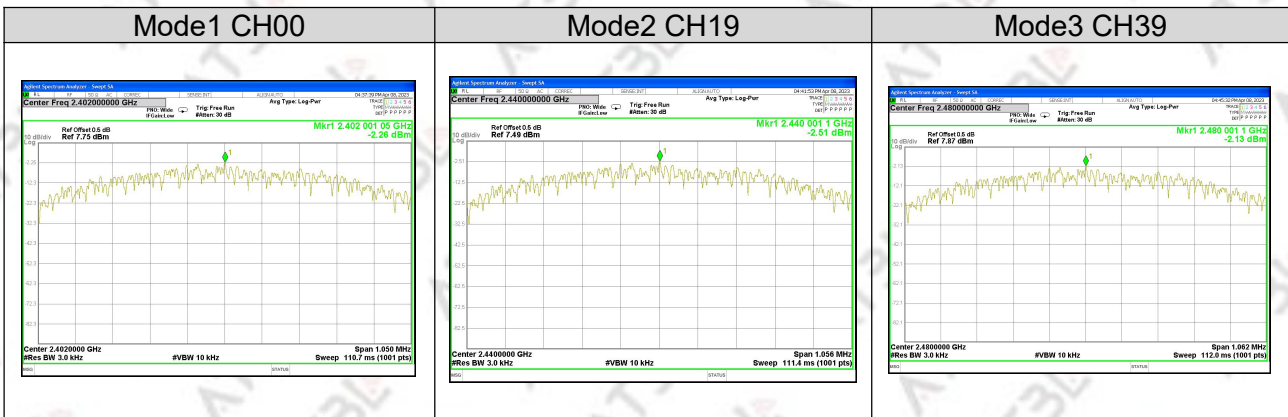

7. BANDWIDTH TEST

7.1 LIMIT

FCC Part 15.247, Subpart C				
Section	Test Item	Limit	Frequency Range (MHz)	Result
15.247(a)(2)	Bandwidth	$\geq 500\text{kHz}$ (6dB bandwidth)	2400-2483.5	PASS

7.2 TEST PROCEDURE

Connect the UUT to the spectrum analyzer and use the following settings:

Center Frequency	The centre frequency of the channel under test
Detector	Peak
RBW	For 6 dB Bandwidth : 100kHz For 99% Bandwidth : 1% to 5% of the occupied bandwidth
VBW	For 6dB Bandwidth : $\geq 3 \times \text{RBW}$ For 99% Bandwidth : approximately $3 \times \text{RBW}$
Trace	Max hold
Sweep	Auto

Allow the trace to stabilize and measure the maximum width of the emission that is constrained by the frequencies associated with the two outermost amplitude points (upper and lower frequencies) that are attenuated by 6 dB and 99% relative to the maximum level measured in the fundamental emission.

7.3 TEST SETUP

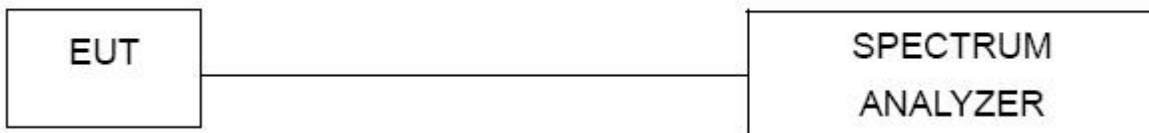

7.4 EUT OPERATION CONDITIONS

The EUT tested system was configured as the statements of 2.3 Unless otherwise a special operating condition is specified in the follows during the testing.

7.5 TEST RESULTS

Temperature:	23.4°C	Relative Humidity:	55%RH
Test Voltage:	DC 5V	Test Mode:	TX Mode1/2/3

Frequency	6dB Bandwidth (kHz)	99% Bandwidth (MHz)	6dB Bandwidth Limit(kHz)	Result
1M bps	2402 MHz	700.0	1.0291	PASS
	2440 MHz	704.0	1.0291	PASS
	2480 MHz	708.0	1.0311	PASS

6dB Bandwidth

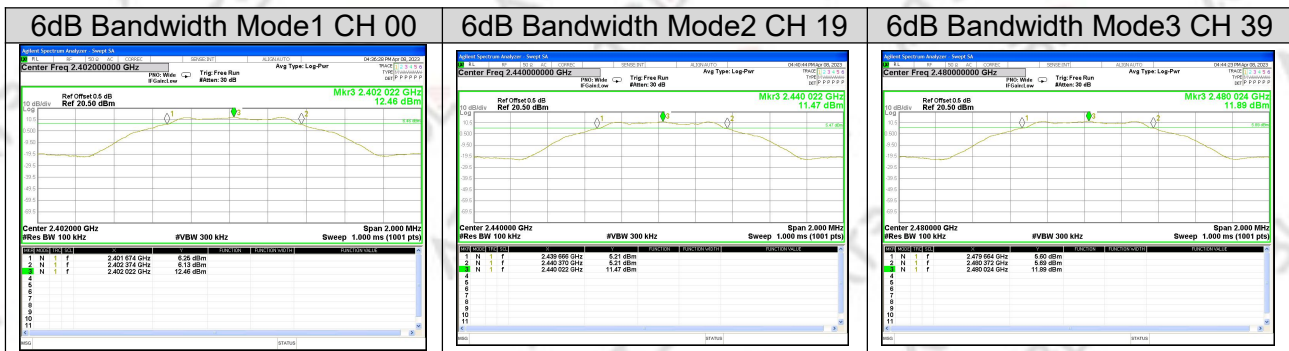

99% Bandwidth

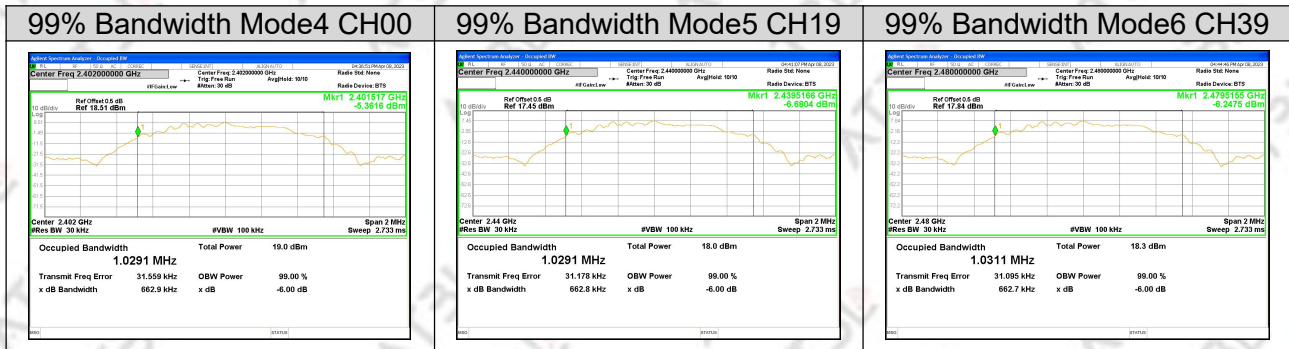

8. PEAK OUTPUT POWER TEST

8.1 LIMIT

FCC Part 15.247, Subpart C				
Section	Test Item	Limit	Frequency Range (MHz)	Result
15.247(b)(3)	Output Power	1 watt or 30dBm	2400-2483.5	PASS

8.2 TEST PROCEDURE

PKPM1 Peak power meter method:

The maximum peak conducted output power may be measured using a broadband peak RF power meter. The power meter shall have a video bandwidth that is greater than or equal to the DTS bandwidth and shall use a fast-responding diode detector.

8.3 TEST SETUP



8.4 EUT OPERATION CONDITIONS

The EUT tested system was configured as the statements of 2.3 Unless otherwise a special operating condition is specified in the follows during the testing.

8.5 TEST RESULTS

Temperature:	23.4 °C	Relative Humidity:	55%RH
Test Voltage:	DC 5V	Test Mode:	TX Mode1/2/3

Test Channel	Frequency	Peak Conducted Output Power	Average Conducted Output Power	LIMIT
	(MHz)	(dBm)	(dBm)	dBm
Mode1 CH00	2402	13.67	13.29	30
Mode2 CH19	2440	13.84	13.48	30
Mode3 CH39	2480	12.89	12.51	30

EIRP Power

Test Channel	Frequency	Peak Conducted Output Power	Antenna Gain	EIRP Power	LIMIT
	(MHz)	(dBm)	(dBi)	(dBm)	dBm
Mode1 CH00	2402	13.67	2.8	16.47	36
Mode2 CH19	2440	13.84	2.8	16.64	36
Mode3 CH39	2480	12.89	2.8	15.69	36

Note: Our power sensor test AVG power has no duty cycle display. The power sensor measures AVG power is Burst power. The software has considered the factor of the duty cycle factor, so it is unnecessary to add it again.

9. ANTENNA REQUIREMENT



9.1 STANDARD REQUIREMENT

15.203 requirement: For intentional device, according to 15.203: an intentional radiator shall be designed to ensure that no antenna other than that furnished by the responsible party shall be used with the device.

9.2 EUT ANTENNA

The EUT antenna is Ceramic Antenna. It comply with the standard requirement.

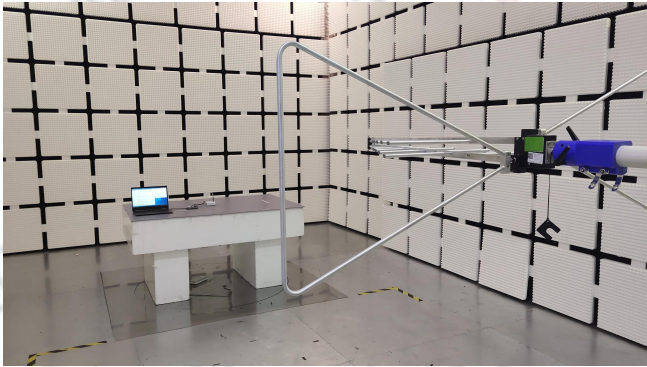
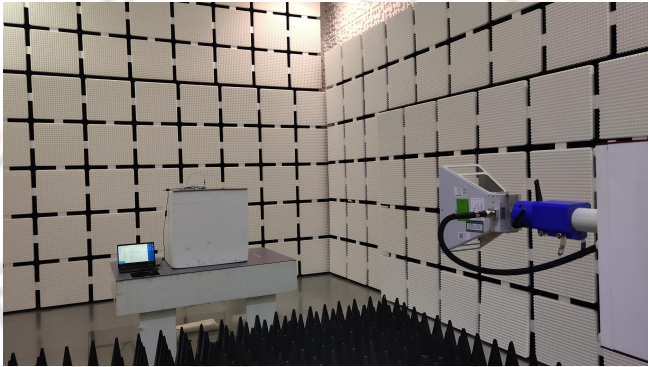
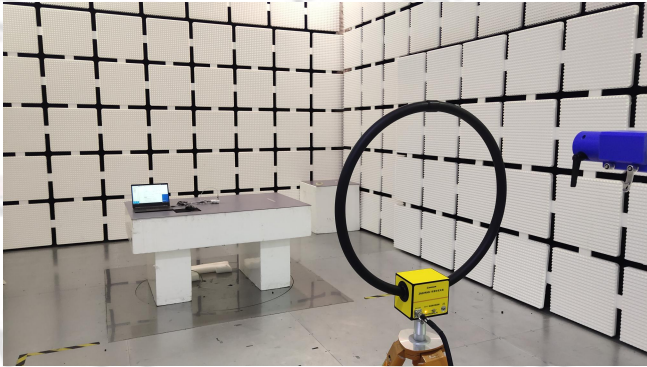
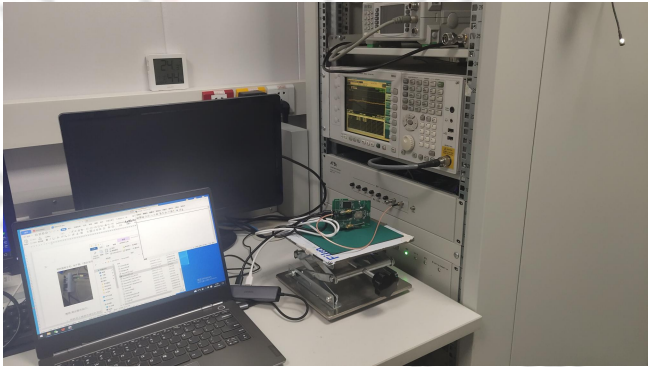
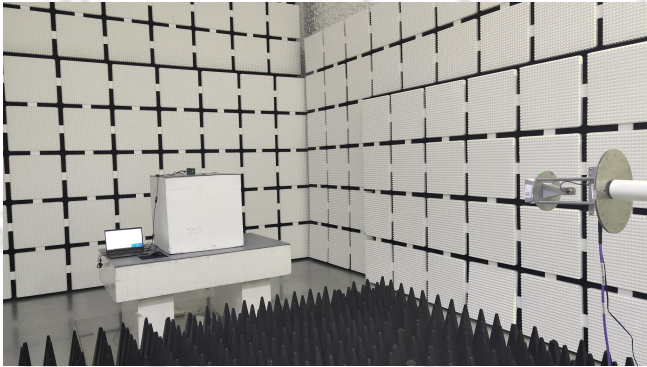
10.APPENDIX- PHOTOS OF TEST SETUP

<p>Radiated Emissions for 30MHz~1GHz</p> 	<p>Radiated Emissions for 1GHz~18GHz</p> 
<p>Radiated Emissions for 9kHz~30MHz</p> 	<p>Conducted for RF</p> 
<p>Radiated Emissions for above 18GHz</p> 	<p>AC Power Line Conducted Emissions</p> 

*****END OF THE REPORT*****