

## FCC Test Report

### (Co-Located)

**Report No.:** RFBAYG-WTW-P23080102-3

**FCC ID:** 2BAGA010011

**Product:** Charging Case

**Brand:** OZLO

**Model No.:** 010011

**Received Date:** 2023/8/4

**Test Date:** 2023/12/18

**Issued Date:** 2024/1/17

**Applicant:** Drowsy Digital Inc

**Address:** 850 New Burton Road Suite 201 19904 Dover Delaware United States  
19904

**Issued By:** Bureau Veritas Consumer Products Services (H.K.) Ltd., Taoyuan Branch  
Lin Kou Laboratories

**Lab Address:** No. 47-2, 14th Ling, Chia Pau Vil., Lin Kou Dist., New Taipei City, Taiwan

**Test Location:** No. 47-2, 14th Ling, Chia Pau Vil., Lin Kou Dist., New Taipei City, Taiwan

**FCC Registration /  
Designation Number:** 198487 / TW2021



This report is governed by, and incorporates by reference, the Conditions of Testing as posted at the date of issuance of this report at <http://www.bureauveritas.com/home/about-us/our-business/cps/about-us/terms-conditions/> and is intended for your exclusive use. Any copying or replication of this report to or for any other person or entity, or use of our name or trademark, is permitted only with our prior written permission. This report sets forth our findings solely with respect to the test samples identified herein. The results set forth in this report are not indicative or representative of the quality or characteristics of the lot from which a test sample was taken or any similar or identical product unless specifically and expressly noted. Our report includes all of the tests requested by you and the results thereof based upon the information that you provided to us. Measurement uncertainty is only provided upon request for accredited tests. Statements of conformity are based on simple acceptance criteria without taking measurement uncertainty into account, unless otherwise requested in writing. You have 60 days from date of issuance of this report to notify us of any material error or omission caused by our negligence or if you require measurement uncertainty; provided, however, that such notice shall be in writing and shall specifically address the issue you wish to raise. A failure to raise such issue within the prescribed time shall constitute your unqualified acceptance of the completeness of this report, the tests conducted and the correctness of the report contents.

## Table of Contents

<b>Release Control Record</b> .....	<b>3</b>
<b>1 Certificate of Conformity</b> .....	<b>4</b>
<b>2 Summary of Test Results</b> .....	<b>5</b>
2.1 Measurement Uncertainty .....	5
2.2 Modification Record .....	5
<b>3 General Information</b> .....	<b>6</b>
3.1 General Description of EUT .....	6
3.2 Antenna Description of EUT .....	6
3.3 Description of Test Modes .....	7
3.3.1 Test Mode Applicability and Tested Channel Detail .....	8
3.4 Description of Support Units .....	9
3.4.1 Configuration of System under Test .....	9
3.5 General Description of Applied Standards .....	10
<b>4 Test Types and Results</b> .....	<b>11</b>
4.1 Radiated Emission and Bandedge Measurement .....	11
4.1.1 Limits of Radiated Emission and Bandedge Measurement .....	11
4.1.2 Test Instruments .....	12
4.1.3 Test Procedure .....	14
4.1.4 Deviation from Test Standard .....	14
4.1.5 Test Setup .....	15
4.1.6 EUT Operating Condition .....	16
4.1.7 Test Results .....	17
<b>5 Construction Photos of EUT</b> .....	<b>20</b>
<b>Appendix – Information of the Testing Laboratories</b> .....	<b>21</b>

### Release Control Record

Issue No.	Description	Date Issued
RFBAYG-WTW-P23080102-3	Original release	2024/1/17

## 1 Certificate of Conformity

**Product:** Charging Case

**Brand:** OZLO

**Test Model:** 010011

**Sample Status:** Engineering sample

**Applicant:** Drowsy Digital Inc

**Test Date:** 2023/12/18

**Standard:** 47 CFR FCC Part 15, Subpart C (Section 15.247)

**Measurement** ANSI C63.10-2013

**procedure:** KDB 558074 D01 15.247 Meas Guidance v05r02

The above equipment has been tested by **Bureau Veritas Consumer Products Services (H.K.) Ltd., Taoyuan Branch**, and found compliance with the requirement of the above standards. The test record, data evaluation & Equipment Under Test (EUT) configurations represented herein are true and accurate accounts of the measurements of the sample's RF characteristics under the conditions specified in this report.

**Prepared by :**

*Annie Chang*

**Date:** 2024/1/17

Annie Chang / Senior Specialist

**Approved by :**

*Jeremy Lin*

**Date:** 2024/1/17

Jeremy Lin / Project Engineer

## 2 Summary of Test Results

Applied Standard	47 CFR FCC Part 15, Subpart C (Section 15.247)		
Clause	Test Item	Result	Remarks
15.205 / 15.209 / 15.247(d)	Unwanted Emissions below 1 GHz	Pass	Meet the requirement of limit. Minimum passing margin is -4.3dB at 34.07MHz.
15.205 / 15.209 / 15.247(d)	Unwanted Emissions above 1 GHz	Pass	Meet the requirement of limit. Minimum passing margin is -15.6dB at 4880.00MHz.

Note: Determining compliance based on the results of the compliance measurement, not taking into account measurement instrumentation uncertainty.

### 2.1 Measurement Uncertainty

Where relevant, the following measurement uncertainty levels have been estimated for tests performed on the EUT as specified in CISPR 16-4-2:

Measurement	Specification	Expanded Uncertainty (k=2) (±)
Unwanted Emissions below 1 GHz	9 kHz ~ 30 MHz	2.38 dB
	30 MHz ~ 1 GHz	5.7 dB
Unwanted Emissions above 1 GHz	1 GHz ~ 6 GHz	4.83 dB
	6 GHz ~ 18 GHz	5.37 dB
	18 GHz ~ 40 GHz	5.24 dB

The other instruments specified are routine verified to remain within the calibrated levels, no measurement uncertainty is required to be calculated.

### 2.2 Modification Record

There were no modifications required for compliance.

### 3 General Information

#### 3.1 General Description of EUT

Product	Charging Case	
Brand	OZLO	
Test Model	010011	
Status of EUT	Engineering sample	
Power Supply Rating	5Vdc form Type C port or 3.85Vdc from battery	
Modulation Type	BT-EDR (QCC5141)	GFSK, $\pi/4$ -DQPSK, 8DPSK
	BT-LE (QCC5141)	GFSK
	BT-LE (NxH3675)	GFSK
Modulation Technology	BT-EDR (QCC5141)	FHSS
	BT-LE (QCC5141)	DTS
	BT-LE (NxH3675)	DTS
Transfer Rate	BT-EDR (QCC5141)	Up to 3 Mbps
	BT-LE (QCC5141)	Up to 2 Mbps
	BT-LE (NxH3675)	Up to 2 Mbps
Number of Channel	2.402 GHz ~ 2.48 GHz	
Operating Frequency	BT-EDR (QCC5141)	79
	BT-LE (QCC5141)	40
	BT-LE (NxH3675)	40
Output Power	BT-EDR (QCC5141)	2.198 mW (3.42 dBm)
	BT-LE (QCC5141)	1.687 mW (2.27 dBm)
	BT-LE (NxH3675)	16.331 mW (12.13 dBm)

Note:

1. The EUT uses following accessory.

Item	Specification
USB A to USB C cable	Shielded without core, 1.0m

2. The EUT has built-in two RF Chips as the following:

RF Chip	Model
1	QCC5141
2	NxH3675

3. Simultaneously transmission condition.

Condition	Technology	
1	BT-EDR (QCC5141)	BT-LE (NxH3675)
2	BT-LE (QCC5141)	BT-LE (NxH3675)

4. The above EUT information is declared by manufacturer and for more detailed features description, please refer to the manufacturer's specifications or User's Manual.

#### 3.2 Antenna Description of EUT

The antenna information is listed as below.

Antenna No.	Gain (dBi)	Antenna Type	Connector Type
Antenna for NXH Chip (Ant 0)	0.5	LDS	N/A
Antenna for QCC Chip (Ant 1)	2	LDS	N/A

Note: The maximum gain was chosen for test.

\*Detail antenna specification please refer to antenna datasheet and/or antenna measurement report

### 3.3 Description of Test Modes

79 channels are provided for BT-EDR:

Channel	Frequency (MHz)	Channel	Frequency (MHz)	Channel	Frequency (MHz)	Channel	Frequency (MHz)
0	2402	20	2422	40	2442	60	2462
1	2403	21	2423	41	2443	61	2463
2	2404	22	2424	42	2444	62	2464
3	2405	23	2425	43	2445	63	2465
4	2406	24	2426	44	2446	64	2466
5	2407	25	2427	45	2447	65	2467
6	2408	26	2428	46	2448	66	2468
7	2409	27	2429	47	2449	67	2469
8	2410	28	2430	48	2450	68	2470
9	2411	29	2431	49	2451	69	2471
10	2412	30	2432	50	2452	70	2472
11	2413	31	2433	51	2453	71	2473
12	2414	32	2434	52	2454	72	2474
13	2415	33	2435	53	2455	73	2475
14	2416	34	2436	54	2456	74	2476
15	2417	35	2437	55	2457	75	2477
16	2418	36	2438	56	2458	76	2478
17	2419	37	2439	57	2459	77	2479
18	2420	38	2440	58	2460	78	2480
19	2421	39	2441	59	2461		

40 channels are provided for BT-LE:

Channel	Frequency (MHz)	Channel	Frequency (MHz)	Channel	Frequency (MHz)	Channel	Frequency (MHz)
0	2402	10	2422	20	2442	30	2462
1	2404	11	2424	21	2444	31	2464
2	2406	12	2426	22	2446	32	2466
3	2408	13	2428	23	2448	33	2468
4	2410	14	2430	24	2450	34	2470
5	2412	15	2432	25	2452	35	2472
6	2414	16	2434	26	2454	36	2474
7	2416	17	2436	27	2456	37	2476
8	2418	18	2438	28	2458	38	2478
9	2420	19	2440	29	2460	39	2480

### 3.3.1 Test Mode Applicability and Tested Channel Detail

EUT Configure Mode	Applicable To		Description
	RE $\ge$ 1G	RE<1G	
-	√	√	Right+Left side earphone charging (Powered from Notebook)

Where **RE $\ge$ 1G**: Radiated Emission above 1GHz  
**RE<1G**: Radiated Emission below 1GHz

#### **Radiated Emission Test (Above 1GHz):**

- Pre-Scan has been conducted to determine the worst-case mode from all possible combinations between available modulations, data rates and antenna ports (if EUT with antenna diversity architecture).
- Following channel(s) was (were) selected for the final test as listed below.

EUT Configure Mode	Mode	Freq. Range (MHz)	Available Channel	Tested Channel	Modulation
-	BT-EDR (QCC5141) + BT-LE (NxH3675)	2402 ~ 2480	0 to 78	78 + 19 (1M)	8DPSK
		2402 ~ 2480	0 to 39		GFSK

#### **Radiated Emission Test (Below 1GHz):**

- Pre-Scan has been conducted to determine the worst-case mode from all possible combinations between available modulations, data rates and antenna ports (if EUT with antenna diversity architecture).
- Following channel(s) was (were) selected for the final test as listed below.

EUT Configure Mode	Mode	Freq. Range (MHz)	Available Channel	Tested Channel	Modulation
-	BT-EDR (QCC5141) + BT-LE (NxH3675)	2402 ~ 2480	0 to 78	78 + 19 (1M)	8DPSK
		2402 ~ 2480	0 to 39		GFSK

#### **Test Condition:**

Applicable To	Environmental Conditions	Input Power	Tested By
<b>RE&gt;1G</b>	25deg. C, 75%RH	120Vac, 60Hz	William Su
<b>RE&lt;1G</b>	23deg. C, 69%RH	120Vac, 60Hz	William Su



### 3.4 Description of Support Units

The EUT has been tested as an independent unit together with other necessary accessories or support units. The following support units or accessories were used to form a representative test configuration during the tests.

ID	Product	Brand	Model No.	Serial No.	FCC ID	Remarks
A	NB	LENOVO	IdeaPad 5 15ITL05	N/A	N/A	Provided by Lab
B	NB Adapter	LENOVO	ADLX65CLGU2A	N/A	N/A	Provided by Lab
C	Left earphone	OZLO	010011L	N/A	2BAGA010011L	Supplied by applicant
D	Right earphone	OZLO	010011R	N/A	2BAGA010011R	Supplied by applicant

ID	Cable Descriptions	Qty.	Length (m)	Shielding (Yes/No)	Cores (Qty.)	Remarks
1	USB A to USB C cable	1	1	Y	0	Supplied by applicant
2	DC cable	1	1.8	N	0	Provided by Lab

#### 3.4.1 Configuration of System under Test

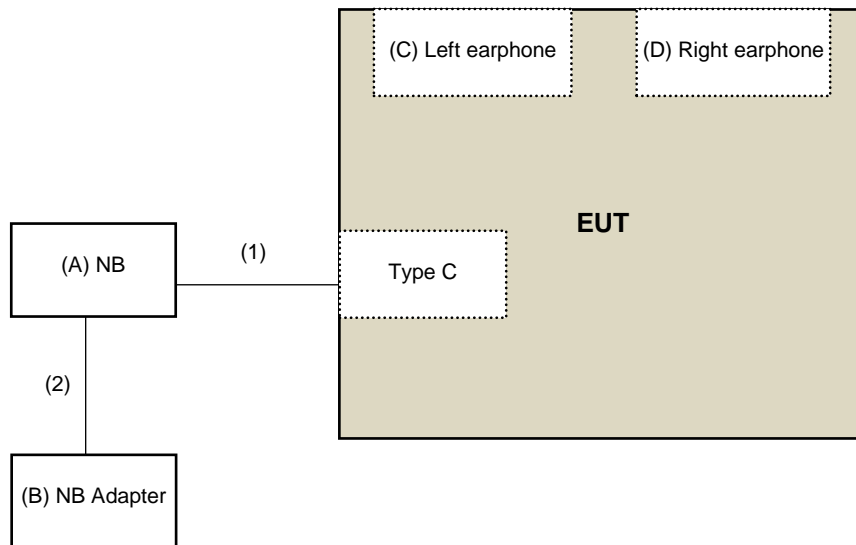

### **3.5 General Description of Applied Standards**

The EUT is a RF Product. According to the specifications of the manufacturer, it must comply with the requirements of the following standards and references:

**Test Standard:**

**FCC Part 15, Subpart C (15.247)**

**ANSI C63.10-2013**

All test items have been performed and recorded as per the above standards.

**References Test Guidance:**

**KDB 558074 D01 15.247 Meas Guidance v05r02**

All test items have been performed as a reference to the above KDB test guidance.

## 4 Test Types and Results

### 4.1 Radiated Emission and Bandedge Measurement

#### 4.1.1 Limits of Radiated Emission and Bandedge Measurement

Radiated emissions up to 1 GHz which fall in the restricted bands must comply with the radiated emission limits specified as below table. Other emissions shall be at least 20 dB below the highest level of the desired power:

Frequencies (MHz)	Field Strength (microvolts/meter)	Measurement Distance (meters)
0.009 ~ 0.490	2400/F(kHz)	300
0.490 ~ 1.705	24000/F(kHz)	30
1.705 ~ 30.0	30	30
30 ~ 88	100	3
88 ~ 216	150	3
216 ~ 960	200	3
Above 960	500	3

Notes:

1. The lower limit shall apply at the transition frequencies.
2. Emission level (dBuV/m) = 20 log Emission level (uV/m).

Radiated emissions above 1 GHz which fall in the restricted bands must comply with the radiated emission limits specified as below table. Other emissions shall be at least 20 dB below the highest level of the desired power:

Frequencies (MHz)	Field Strength (microvolts/meter)	Measurement Distance (meters)
Above 960	500	3

Notes:

1. The lower limit shall apply at the transition frequencies.
2. Emission level (dBuV/m) = 20 log Emission level (uV/m).
3. For frequencies above 1000 MHz, the field strength limits are based on average detector, however, the peak field strength of any emission shall not exceed the maximum permitted average limits, specified above by more than 20 dB under any condition of modulation.

#### 4.1.2 Test Instruments

##### Unwanted Emissions below 1 GHz

Description Manufacturer	Model No.	Serial No.	Calibrated Date	Calibrated Until
Bi_Log Antenna Schwarzbeck	VULB 9168	137	2023/10/13	2024/10/12
Coupling / Decoupling Network Schwarzbeck	CDNE-M2	00097	2023/5/25	2024/5/24
	CDNE-M3	00091	2023/5/25	2024/5/24
Loop Antenna EMCI	LPA600	270	2023/9/4	2024/9/3
MXE EMI Receiver Agilent	N9038A	MY51210129	2023/3/24	2024/3/23
		MY51210137	2023/6/5	2024/6/4
Preamplifier EMCI	EMC001340	980269	2023/6/27	2024/6/26
Preamplifier HP	8447D	2432A03504	2023/2/16	2024/2/15
RF Coaxial Cable Pacific	8D-FB	Cable-CH6-02	2023/6/27	2024/6/26
Signal Analyzer R&S	FSV40	101544	2023/5/9	2024/5/8
Software BVADT	Radiated_V8.7.08	N/A	N/A	N/A
Tower ADT	AT100	0306	N/A	N/A
Turn Table ADT	TT100	0306	N/A	N/A

##### Notes:

1. The calibration interval of the above test instruments is 12 months and the calibrations are traceable to NML/ROC and NIST/USA
2. The test was performed in Linkou 966 Chamber 6 (CH 6).
3. Tested Date: 2023/12/18

Unwanted Emissions above 1 GHz

Description Manufacturer	Model No.	Serial No.	Calibrated Date	Calibrated Until
Band Pass Filter Micro-Tronics	BRM17690	005	2023/5/25	2024/5/24
Boresight antenna tower fixture BV	BAF-02	6	N/A	N/A
High Pass Filter Wainwright	WHK 3.1/18G-10SS	SN 8	2023/5/25	2024/5/24
Horn Antenna EMCO	3115	00028257	2023/11/12	2024/11/11
Horn Antenna ETS-Lindgren	3117-PA	00215857	2023/11/12	2024/11/11
Horn Antenna Schwarzbeck	BBHA 9170	212	2023/10/16	2024/10/15
		BBHA9170241	2023/10/16	2024/10/15
MXE EMI Receiver Agilent	N9038A	MY51210129	2023/3/24	2024/3/23
		MY51210137	2023/6/5	2024/6/4
Notch Filter Micro-Tronics	BRC50703-01	010	2023/5/25	2024/5/24
Preamplifier EMCI	EMC0126545 EMC184045B	980076	2023/2/16	2024/2/15
		980175	2023/9/2	2024/9/1
		980235	2023/2/16	2024/2/15
Preamplifier HP	8449B	3008A01201	2023/2/16	2024/2/15
RF Coaxial Cable EMCI	EMC102-KM-KM-1000 EMC104	200310	2023/3/12	2024/3/11
		190801	2023/9/13	2024/9/12
		190804	2023/9/13	2024/9/12
RF Coaxial Cable HUBER+SUHNER	SF-104	Cable-CH6-01	2023/9/13	2024/9/12
Signal Analyzer R&S	FSV40	101042	2023/9/5	2024/9/4
		101544	2023/5/9	2024/5/8
Software BVADT	Radiated_V7.7.1.1.1	N/A	N/A	N/A
Tower ADT	AT100	0306	N/A	N/A
Turn Table ADT	TT100	0306	N/A	N/A

Notes:

1. The calibration interval of the above test instruments is 12 months and the calibrations are traceable to NML/ROC and NIST/USA
2. The test was performed in Linkou 966 Chamber 6 (CH 6).
3. Tested Date: 2023/12/18

#### 4.1.3 Test Procedure

##### **For Radiated emission below 30MHz**

- a. The EUT was placed on the top of a rotating table 0.8 meters above the ground at 3 meter chamber room for test. The table was rotated 360 degrees to determine the position of the highest radiation.
- b. The EUT was set 3 meters away from the interference-receiving antenna, which was mounted on the top of a variable-height antenna tower.
- c. Parallel, perpendicular, and ground-parallel orientations of the antenna are set to make the measurement.
- d. For each suspected emission, the EUT was arranged to its worst case and the rotatable table was turned from 0 degrees to 360 degrees to find the maximum reading.
- e. The test-receiver system was set to Quasi-Peak Detect Function and Specified Bandwidth with Maximum Hold Mode, except for the frequency band (9 kHz to 90 kHz and 110 kHz to 490 kHz) set to average detect function and peak detect function.

##### Notes:

1. The resolution bandwidth and video bandwidth of test receiver/spectrum analyzer is 200 Hz at frequency below 150 kHz.
2. The resolution bandwidth and video bandwidth of test receiver/spectrum analyzer is 9 kHz or 10 kHz at frequency (150 kHz to 30 MHz).
3. All modes of operation were investigated and the worst-case emissions are reported.

##### **For Radiated emission above 30MHz**

- a. The EUT was placed on the top of a rotating table 0.8 meters above the ground at 3 meter chamber room for test. The table was rotated 360 degrees to determine the position of the highest radiation.
- b. The EUT was set 3 meters away from the interference-receiving antenna, which was mounted on the top of a variable-height antenna tower.
- c. The height of antenna is varied from one meter to four meters above the ground to determine the maximum value of the field strength. Both horizontal and vertical polarizations of the antenna are set to make the measurement.
- d. For each suspected emission, the EUT was arranged to its worst case and then the antenna was tuned to heights from 1 meter to 4 meters and the rotatable table was turned from 0 degrees to 360 degrees to find the maximum reading.
- e. The test-receiver system was set to quasi-peak detect function and specified bandwidth with maximum hold mode when the test frequency is below 1 GHz.

##### Notes:

1. The resolution bandwidth and video bandwidth of test receiver/spectrum analyzer is 120 kHz for Quasi-peak detection (QP) at frequency below 1 GHz.
2. All modes of operation were investigated and the worst-case emissions are reported.

#### 4.1.4 Deviation from Test Standard

No deviation.

#### 4.1.5 Test Setup

##### For Radiated emission below 30MHz

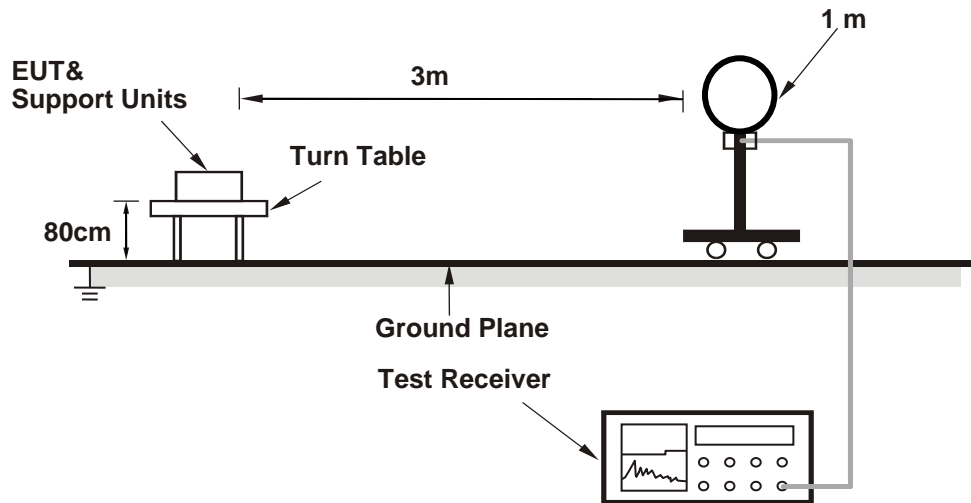

##### For Radiated emission 30MHz to 1GHz

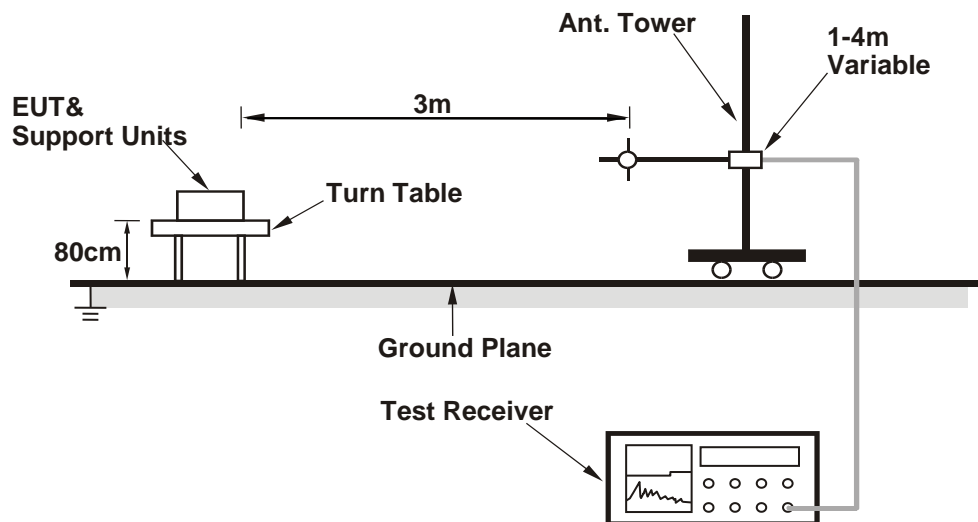

**For Radiated emission above 1GHz**

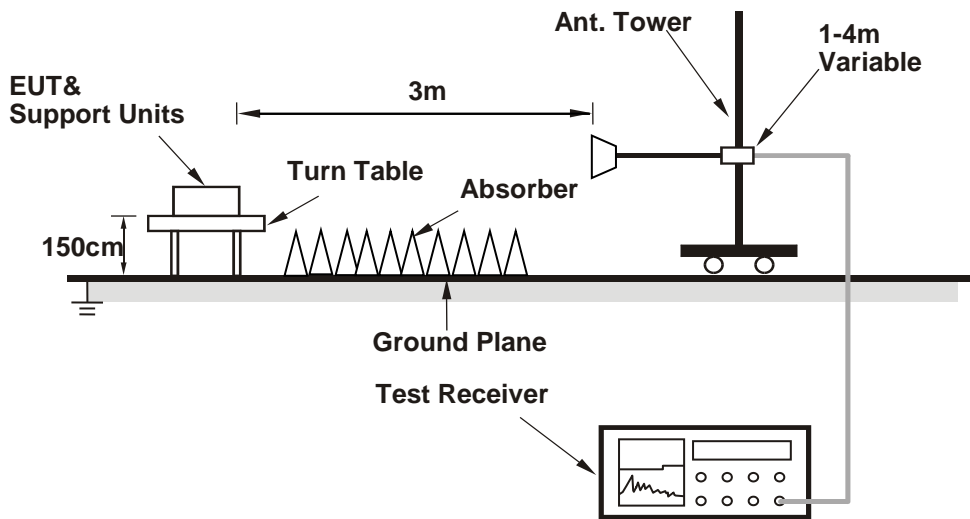

For the actual test configuration, please refer to the attached file (Test Setup Photo).

**4.1.6 EUT Operating Condition**

**BT-EDR (QCC5141)**

Controlling software (BlueTest v3.3.16.1687) has been activated to set the EUT under transmission condition continuously at specific channel frequency.

**BT-LE (NxH3675)**

Controlling software (cmd v10.0.19045.3803) has been activated to set the EUT under transmission condition continuously at specific channel frequency.



#### 4.1.7 Test Results

Above 1GHz data:

<b>RF Mode</b>	BT-EDR (QCC5141) + BT-LE (NxH3675)	<b>Channel</b>	CH 78 : 2480 MHz + CH 19 : 2440 MHz (1M)
<b>Frequency Range</b>	1 GHz ~ 25 GHz	<b>Detector Function &amp; Bandwidth</b>	PK: RB=1 MHz, VB=3 MHz, DET=Peak AV: Refer to note 5 as below (BT-EDR) AV: RB=1 MHz, VB=3 kHz, DET=Peak (BT-LE)
<b>Input Power</b>	120 Vac, 60 Hz	<b>Environmental Conditions</b>	25°C, 75% RH
<b>Tested By</b>	William Su		

#### Antenna Polarity & Test Distance : Horizontal at 3 m

No	Frequency (MHz)	Emission Level (dBuV/m)	Limit (dBuV/m)	Margin (dB)	Antenna Height (m)	Table Angle (Degree)	Raw Value (dBuV)	Correction Factor (dB/m)
1	2483.50	53.4 PK	74.0	-20.6	3.98 H	182	54.4	-1.0
2	2483.50	22.6 AV	54.0	-31.4	3.98 H	182	23.6	-1.0
3	4880.00	48.5 PK	74.0	-25.5	1.72 H	252	40.6	7.9
<b>4</b>	<b>4880.00</b>	<b>38.4 AV</b>	<b>54.0</b>	<b>-15.6</b>	<b>1.72 H</b>	<b>252</b>	<b>30.5</b>	<b>7.9</b>
5	4960.00	50.7 PK	74.0	-23.3	2.25 H	63	42.8	7.9
6	4960.00	19.9 AV	54.0	-34.1	2.25 H	63	12.0	7.9

#### Antenna Polarity & Test Distance : Vertical at 3 m

No	Frequency (MHz)	Emission Level (dBuV/m)	Limit (dBuV/m)	Margin (dB)	Antenna Height (m)	Table Angle (Degree)	Raw Value (dBuV)	Correction Factor (dB/m)
1	2483.50	52.5 PK	74.0	-21.5	2.56 V	123	53.5	-1.0
2	2483.50	21.7 AV	54.0	-32.3	2.56 V	123	22.7	-1.0
3	4880.00	47.0 PK	74.0	-27.0	2.58 V	185	39.1	7.9
4	4880.00	37.0 AV	54.0	-17.0	2.58 V	185	29.1	7.9
5	4960.00	48.5 PK	74.0	-25.5	1.72 V	228	40.6	7.9
6	4960.00	17.7 AV	54.0	-36.3	1.72 V	228	9.8	7.9

#### Remarks:

- Emission Level(dBuV/m) = Raw Value(dBuV) + Correction Factor(dB/m)
- Correction Factor(dB/m) = Antenna Factor(dB/m) + Cable Factor(dB) – Pre-Amplifier Factor(dB)
- Margin value = Emission Level – Limit value
- The other emission levels were very low against the lim
- No. 1, 2, 5, 6, the average value of fundamental and harmonic frequency is: Average = Peak value + 20 log(Duty cycle) Where the duty cycle correction factor is calculated from following formula:  
20 log(Duty cycle) = 20 log(2.9 ms / 100 ms) = -30.8 dB

Below 1GHz data:

<b>RF Mode</b>	BT-EDR (QCC5141) + BT-LE (NxH3675)	<b>Channel</b>	CH 78 : 2480 MHz + CH 19 : 2440 MHz (1M)
<b>Frequency Range</b>	30 MHz ~ 1 GHz	<b>Detector Function &amp; Bandwidth</b>	QP: RB=120kHz, DET=Quasi-Peak
<b>Input Power</b>	120 Vac, 60 Hz	<b>Environmental Conditions</b>	23°C, 69% RH
<b>Tested By</b>	William Su		

**Antenna Polarity & Test Distance : Horizontal at 3 m**

No	Frequency (MHz)	Emission Level (dBuV/m)	Limit (dBuV/m)	Margin (dB)	Antenna Height (m)	Table Angle (Degree)	Raw Value (dBuV)	Correction Factor (dB/m)
1	34.80	23.4 QP	40.0	-16.6	1.11 H	333	33.8	-10.4
2	71.56	24.1 QP	40.0	-15.9	1.55 H	37	35.5	-11.4
3	96.25	23.1 QP	43.5	-20.4	1.65 H	190	37.0	-13.9
4	134.57	27.0 QP	43.5	-16.5	1.52 H	217	36.6	-9.6
5	201.11	32.4 QP	43.5	-11.1	1.36 H	126	43.5	-11.1
6	328.91	28.6 QP	46.0	-17.4	1.00 H	166	34.0	-5.4

**Remarks:**

1. Emission Level(dBuV/m) = Raw Value(dBuV) + Correction Factor(dB/m)
2. Correction Factor(dB/m) = Antenna Factor(dB/m) + Cable Factor(dB) – Pre-Amplifier Factor(dB)
3. Margin value = Emission Level – Limit value
4. The other emission levels were very low against the limit of frequency range 30 MHz ~ 1 GHz.
5. The frequency range 9 kHz ~ 30 MHz: all emissions are more than 20 dB below the limit, therefore do not be recorded in this report.

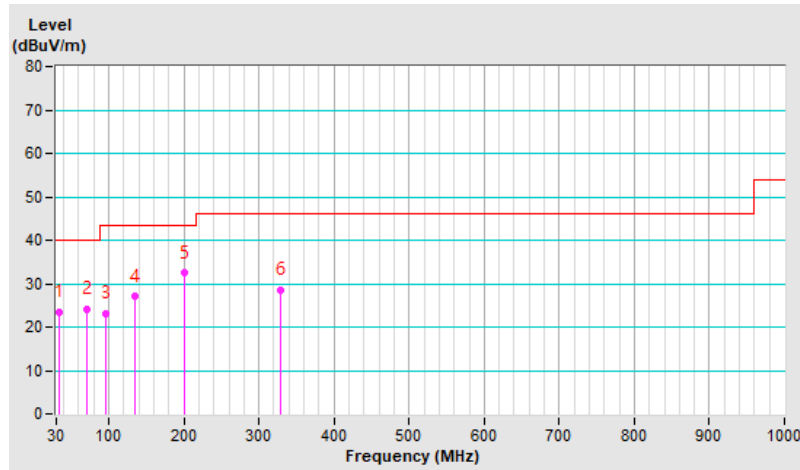

<b>RF Mode</b>	BT-EDR (QCC5141) + BT-LE (NxH3675)	<b>Channel</b>	CH 78 : 2480 MHz + CH 19 : 2440 MHz (1M)
<b>Frequency Range</b>	30 MHz ~ 1 GHz	<b>Detector Function &amp; Bandwidth</b>	QP: RB=120kHz, DET=Quasi-Peak
<b>Input Power</b>	120 Vac, 60 Hz	<b>Environmental Conditions</b>	23°C, 69% RH
<b>Tested By</b>	William Su		

Antenna Polarity & Test Distance : Vertical at 3 m								
No	Frequency (MHz)	Emission Level (dBuV/m)	Limit (dBuV/m)	Margin (dB)	Antenna Height (m)	Table Angle (Degree)	Raw Value (dBuV)	Correction Factor (dB/m)
1	34.07	35.7 QP	40.0	-4.3	1.00 V	49	46.2	-10.5
2	95.96	35.6 QP	43.5	-7.9	1.32 V	218	49.4	-13.8
3	134.52	27.7 QP	43.5	-15.8	1.44 V	102	37.3	-9.6
4	194.66	23.1 QP	43.5	-20.4	1.25 V	211	34.1	-11.0
5	329.63	26.2 QP	46.0	-19.8	1.65 V	306	31.6	-5.4
6	393.17	23.9 QP	46.0	-22.1	1.59 V	189	28.3	-4.4

**Remarks:**

1. Emission Level(dBuV/m) = Raw Value(dBuV) + Correction Factor(dB/m)
2. Correction Factor(dB/m) = Antenna Factor(dB/m) + Cable Factor(dB) – Pre-Amplifier Factor(dB)
3. Margin value = Emission Level – Limit value
4. The other emission levels were very low against the limit of frequency range 30 MHz ~ 1 GHz.
5. The frequency range 9 kHz ~ 30 MHz: all emissions are more than 20 dB below the limit, therefore do not be recorded in this report.

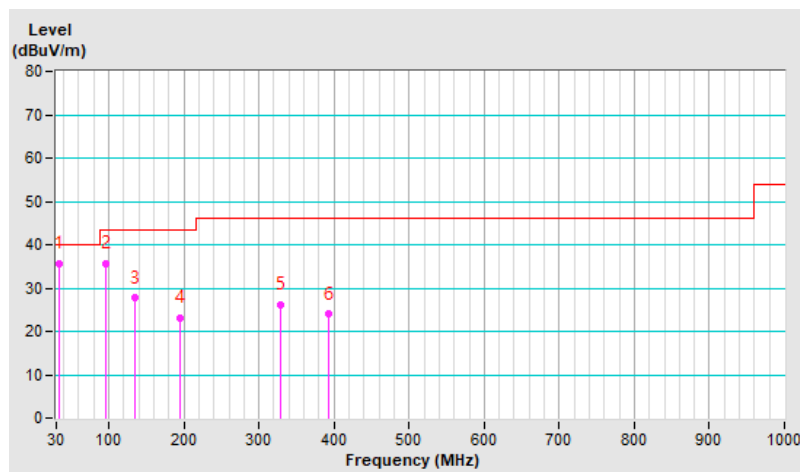

## 5 Construction Photos of EUT.

Please refer to the attached file (Test Setup Photo)

## Appendix – Information of the Testing Laboratories

We, Bureau Veritas Consumer Products Services (H.K.) Ltd., Taoyuan Branch, were founded in 1988 to provide our best service in EMC, Radio, Telecom and Safety consultation. Our laboratories are FCC recognized accredited test firms and accredited according to ISO/IEC 17025.

If you have any comments, please feel free to contact us at the following:

**Lin Kou EMC/RF Lab**

Tel: 886-2-26052180

Fax: 886-2-26051924

**Hsin Chu EMC/RF/Telecom Lab**

Tel: 886-3-6668565

Fax: 886-3-6668323

**Hwa Ya EMC/RF/Safety**

Tel: 886-3-3183232

Fax: 886-3-3270892

**Email:** [service.adt@tw.bureauveritas.com](mailto:service.adt@tw.bureauveritas.com)

**Web Site:** <http://ee.bureauveritas.com.tw>

The address and road map of all our labs can be found in our web site also.

--- END ---