

# Antenna Measurement System Information

## ● Antenna Information

Manufacturer: Pegatron

Brand: Humane

Model: 13EP-5DQ1T01

## ● Measurement OTA Chamber

- MVG SG 24-S 3D fully anechoic chamber, also known as Satimo chamber.
- The list of antenna engineers performed antenna passive measurement activities:
- Gary2\_Chang (gary2\_chang@pegatroncorp.com)
- William1\_Lin (william1\_lin@pegatroncorp.com)

## ● Test Equipment

- Annual calibration by an ISO 17025 accredited laboratory is performed on all test equipment. The following test equipment is typically used:

Network Analyzer	ENA E5063A
------------------	------------

The list of test equipment calibration information are as follows :

- MVG SG 24-S 3D fully anechoic antenna test chamber
- Agilent E5063A Network analyzer
- Agilent E5063A Network analyzer calibration date : 2023 / 04 / 19
- Agilent E5063A Network analyzer calibration name of personnel : Stan Lin

## ● Test Software

- The test equipment operates under the control of commercial test software. For OTA chambers sold by MVG, WaveStudio 22.4 is used.

## ● Test Method

- EIRP measurement is based on industry-standard method described in CTIA OTA Test Plan (current version 3.9.4). Peak gain (Horizontal and Vertical Polarization) is calculated by subtracting Conducted Power from the measured maximum EIRP. Testing is performed with Antenna integrated in the product Below is the measurement summary from the specification:

Figure 4-2 shows a typical real world configuration for measuring the path loss. In this case, a reference antenna with known gain is used in place of the theoretical isotropic source. The path loss may then be determined from the power into the reference antenna by adding the gain of the reference antenna. That is:

EQUATION 4.2

$$P_{ISO} = P_{RA} + G_{RA}$$

where  $P_{RA}$  is the power radiated by reference antenna, and  $G_{RA}$  is the gain of the reference antenna, so that:

EQUATION 4.3

$$PL = P_{RA} + G_{RA} - P_{TE}$$

FIGURE 4-2 TYPICAL CONFIGURATION FOR MEASURING PATH LOSS

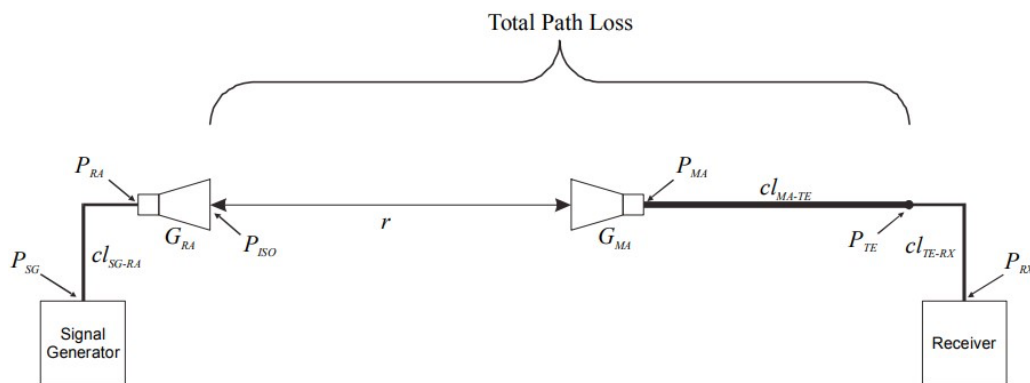

$$P_{RA} - P_{TE} = P_{RX}' - P_{RX}$$

FIGURE 4-3 CABLE REFERENCE CALIBRATION CONFIGURATION

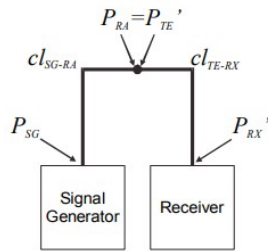

where  $P_{RX}'$  is the power measured at the receiver during the cable reference test, and  $P_{RX}$  is the power measured at the receiver during the range path loss measurement in Figure 4-2. Note that this formulation assumes that the effects of the reference antenna VSWR are accounted for in the gain of the reference antenna. For more information on this subject, refer to [1]. Thus, the path loss is then just given by:

EQUATION 4.5

$$PL = G_{RA} + P_{RX}' - P_{RX}$$

● Typical Setup for MVG SG 24-S

## Satimo 3D Chamber Instrument Setup – E5063A Passive

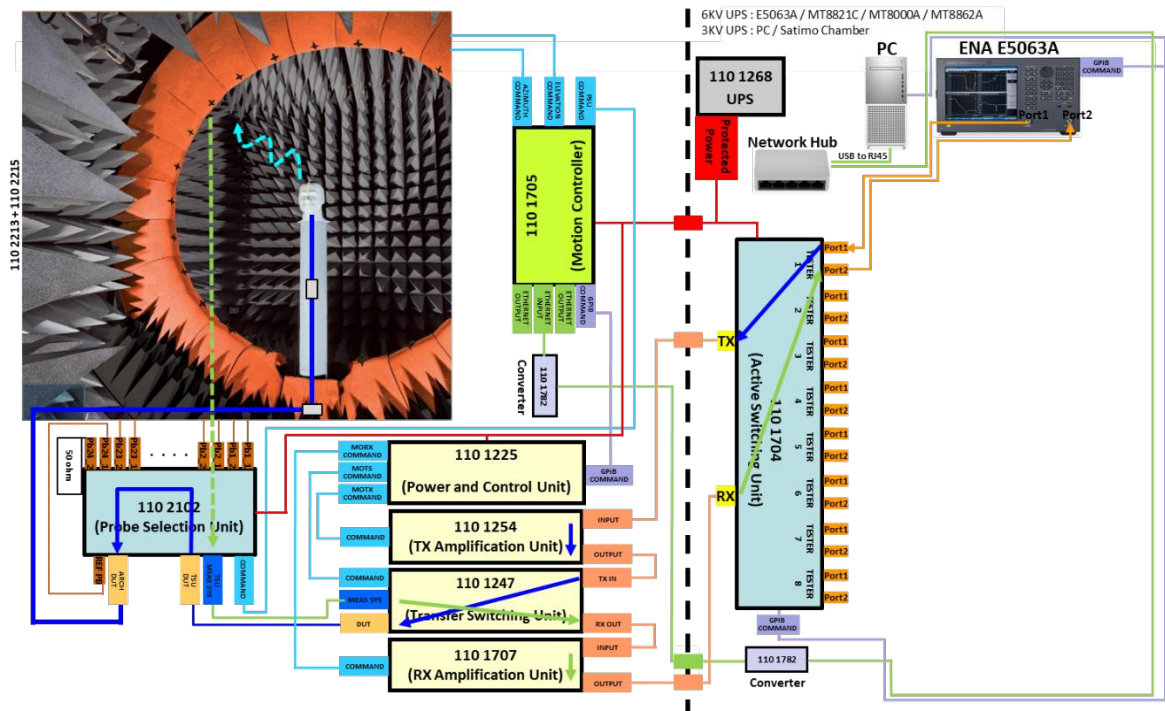

- **Antenna Description**

<b>Description</b>		
Antenna Type (Upper Antenna,Antenna 1)	PIFA Type	
Antenna Type (Lower Antenna,Antenna 2)	PIFA Type	
Peak Gain(Antenna 1) [V-pol / H-pol]	<b><u>V-Polarization</u></b>	<b><u>H-Polarization</u></b>
	Band1=-8.01 dBi	Band1=-7.05 dBi
	Band2=-8.52 dBi	Band2=-8.24 dBi
	Band3=-11.6 dBi	Band3=-11.04 dBi
	Band4=-11.85 dBi	Band4=-10.96 dBi
	Band5=-9.37 dBi	Band5=-9.37 dBi
	Band7=-3.76 dBi	Band7=-4.07 dBi
	Band8=-9.14 dBi	Band8=-9.18 dBi
	Band12=-13.1 dBi	Band12=-12.91 dBi
	Band17=-13.1 dBi	Band17=-12.91 dBi
	Band20=-9.37 dBi	Band20=-9.37 dBi
	Band26=-8.52 dBi	Band26=-8.52 dBi
	Band66=-11.6 dBi	Band66=-11.04 dBi
	Band71=-13.87 dBi	Band71=-14.38 dBi
Band38=-3.47 dBi	Band38=-3.1 dBi	
Band41=-3.47 dBi	Band41=-3.1 dBi	
Peak Gain(Antenna 2) [V-pol / H-pol]	<b><u>V-Polarization</u></b>	<b><u>H-Polarization</u></b>
	Wi-Fi 2.4GHz =-4.57 dBi	Wi-Fi 2.4GHz =-4.63 dBi
	<b><u>Wi-Fi 5GHz:</u></b>	<b><u>Wi-Fi 5GHz</u></b>
	5200MHz =-2.66 dBi	5200MHz =-3.58 dBi
	5500MHz =-5.37 dBi	5500MHz =-4.88 dBi
	5775MHz =-4.88 dBi	5775MHz =-4.48 dB
Cable Loss (Antenna 1)	without antenna cable	
Cable Loss (Antenna 2)	without antenna cable	
RF Connector	none	
Cable Diameter	none	