

Studebaker



Digital Bluetooth AM/FM Alarm Clock Radio

SB3500 OWNER'S MANUAL



Please read this Instruction Manual carefully before using the unit and retain it for future reference

Please contact Spectra Customer Service at 1-800-777-5331 if you have any questions about operating this product

B

WARNING

TO PREVENT FIRE OR SHOCK HAZARD, DO NOT USE THIS PLUG WITH AN EXTENSION CORD, RECEPTACLE OR OTHER OUTLET UNLESS THE BLADES CAN BE FULLY INSERTED TO PREVENT BLADE EXPOSURE. TO PREVENT FIRE OR SHOCK HAZARD, DO NOT EXPOSE THIS APPLIANCE TO RAIN OR MOISTURE.



The Rating plate is located at the bottom enclosure of the apparatus

IMPORTANT SAFETY INSTRUCTIONS

1. Read these instructions.
2. Keep these instructions.
3. Heed all warnings.
4. Follow all instructions.
5. Do not use this apparatus near water.
6. Clean only with dry cloth.
7. Do not block any ventilation openings. Install in accordance with the manufacturer's instructions.
8. Do not install near any heat sources such as radiators, heat registers, stoves, or other apparatus (including amplifiers) that product heat.
9. AC adaptor is used as disconnect device and it should remain readily operable during intended use. In order to disconnect the apparatus from the mains completely, the AC adaptor should be disconnected from the mains socket outlet completely.
10. Only use attachments/accessories specified by the manufacturer.
11. Unplug this apparatus during lightning storms or when unused for a long period of time.
12. Refer all servicing to qualified service personnel. Servicing is required when the apparatus has been damaged in any way, such as power-supply cord or plug is damaged, liquid has been spilled or objects have fallen into the apparatus, the apparatus has been exposed to rain or moisture, does not operate normally, or has been dropped.
13. This appliance shall not be exposed to dripping or splashing water and that no object filled with liquids such as vases shall be placed on the apparatus.
14. Do not overload wall outlet. Use only power source as indicated.
15. Use replacement part as specified by the manufacturer.
16. Upon completion of any service or repairs to this product, ask the service technician to perform safety checks.

17. Power Sources - This product should be operated only from the type of power source indicated on the marking label. If you are not sure of the type of power supply to your home, consult your product dealer or local power company. For products intended to operate from battery power, or other sources, refer to the operating instruction.
18. Object and Liquid Entry - Never push objects of any kind into this product through openings as they may touch dangerous voltage points or short-out parts that could result in a fire or electric shock. Never spill liquid of any kind on the product.
19. Damage Requiring Service - Unplug this product from the wall outlet and refer servicing to qualified service personnel under the following conditions:
 - a) When the power-supply cord or plug is damaged,
 - b) If liquid has been spilled, or objects have fallen into the product,
 - c) If the product has been exposed to rain or water,
 - d) If the product does not operate normally by following the operating instructions. Adjust only those controls that are covered by the operating instructions as an improper adjustment of other controls may result in damage and will often require extensive work by a qualified technician to restore the product to its normal operation.
 - e) If the product has been dropped or damaged in any way, and
 - f) When the product exhibits a distinct change in performance - this indicates a need for service.
20. The battery shall not be exposed to excessive heat such as sunshine, fire or the like.
21. Minimum distances of 4 inches around the apparatus for sufficient ventilation.
22. The ventilation should not be impeded by covering the ventilation openings with items, such as newspapers, tablecloths, curtains, etc.
23. No open flame sources, such as lit candles, should be placed on the product.
24. The use of apparatus in moderate climates.
25. Attention should be drawn to the environmental aspects of battery disposal.

SAVE THESE INSTRUCTIONS

COMPLIANCE WITH FCC REGULATIONS

FCC ID: 2BABY6361442

This device complies with Part 15 of the FCC Rules. Operation is subject to the following two conditions:

- (1) This device may not cause harmful interference, and
- (2) This device must accept any interference received, including interference that may cause undesired operation.

This equipment has been tested and found to comply with the limits for a class B digital device, pursuant to Part 15 of the FCC Rules. These limits are designed to provide reasonable protection against harmful interference in a residential installation. This equipment generates uses and can radiate radio frequency energy and, if not installed and used in accordance with the instructions, may cause harmful interference to radio communications. However, there is no guarantee that interference will not occur in a particular installation. If this equipment does cause harmful interference to radio or television reception, which can be determined by turning the equipment off and on, the user is encouraged to try to correct the interference by one or more of the following measures:

- Reorient or relocate the receiving antenna.
- Increase the separation between the equipment and receiver.
- Connect the equipment into an outlet on a circuit different from that to which the receiver is connected.
- Consult the dealer or an experienced radio/TV technician for help.

CAUTION: Changes or modifications not expressly approved by the party responsible for compliance could void the user's authority to operate the equipment.

PROTECT YOUR FURNITURE!!

This system is equipped with non-skid rubber 'feet' to prevent the product from moving when you operate the controls. These 'feet' are made from non-migrating rubber material specially formulated to avoid leaving any marks or stains on your furniture. However certain types of oil-based furniture polishes, wood preservatives, or cleaning sprays may cause the rubber 'feet' to soften and leave marks or a rubber residue on the furniture.

To prevent any damage to your furniture we strongly recommend that you purchase small self-adhesive felt pads, available at hardware stores and home improvement centers everywhere, and apply these pads to the bottom of the rubber 'feet' before you place the product on fine wooden furniture.

DEAR STUDEBAKER CUSTOMER

Selecting fine audio equipment such as the unit you've just purchased is only the start of your musical enjoyment. Now it's time to consider how you can maximize the fun and excitement your equipment offers. This manufacturer and the Electronic Industries Association's Consumer Electronics Group want you to get the most out of your equipment by playing it at a safe level. One that lets the sound come through loud and clear without annoying blaring or distortion and, most importantly, without affecting your sensitive hearing.

Sound can be deceiving. Over time your hearing "comfort level" adapts to higher volumes of sound. So, what sounds "normal" can actually be loud and harmful to your hearing. Protect against this by setting your equipment at a safe level BEFORE your hearing adapts.

To establish a safe level:

- Start your volume control at a low setting.
- Slowly increase the sound until you can hear it comfortably and clearly, and without distortion.

Once you have established a comfortable sound level:

- Set the dial and leave it there.

Taking a minute to do this now will help to prevent hearing damage or loss in the future. After all, we want you listening for a lifetime.

We Want You Listening for a Lifetime

Used wisely, your new sound equipment will provide a lifetime of fun and enjoyment. Since hearing damage from loud noise is often undetectable until it is too late, this manufacturer and the Electronic Industries Association's Consumer Electronics Group recommend you avoid prolonged exposure to excessive noise.



Customer's Record:



The serial number of this product is found on its bottom. You should note the serial number of this unit in the space provided as a permanent record of your purchase to aid in identification in the event of theft or loss.

Model Number: SB3500

Serial Number:

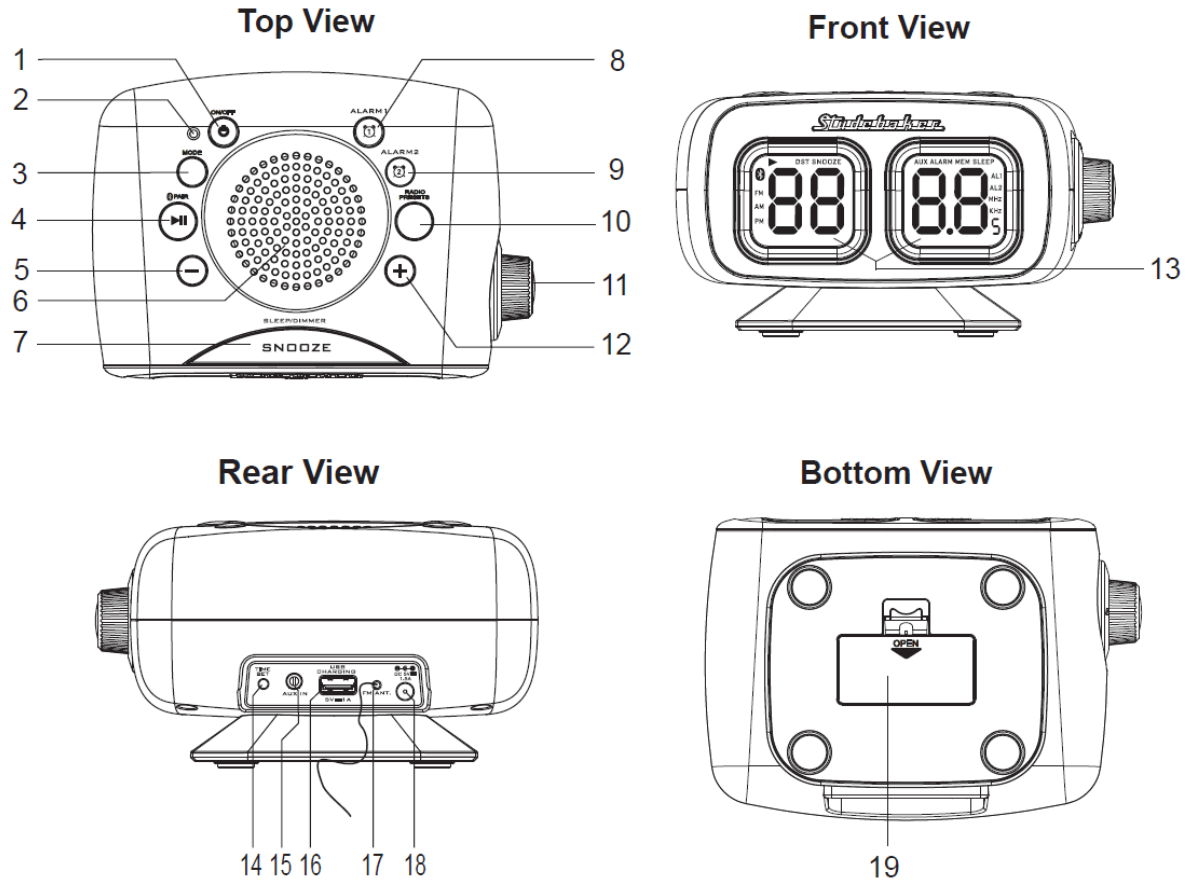
LOCATION OF CONTROLS



- | | |
|--|----------------------|
| 1 POWER  BUTTON | 11 VOLUME CONTROL |
| 2 POWER INDICATOR | 12 + BUTTON |
| 3 MODE BUTTON | 13 LCD DISPLAY |
| 4 PLAY/PAUSE  /  PAIR BUTTON | 14 TIME SET BUTTON |
| 5 - BUTTON | 15 AUX IN JACK |
| 6 SPEAKER | 16 USB CHARGING PORT |
| 7 SNOOZE / DIMMER / SLEEP BUTTON | 17 FM ANTENNA |
| 8 ALARM 1 BUTTON | 18 DC IN JACK |
| 9 ALARM 2 BUTTON | 19 BATTERY DOOR |
| 10 RADIO PRESETS BUTTON | |

POWER SOURCE (AC ADAPTOR ONLY)

The SB3500 is powered by an external AC-DC adaptor with an output of DC 5V --- 1.5A ◇ ◇ ◇ .

The unit is also equipped with a battery back-up system for the clock that is powered by 2 x AAA batteries (Not included).

POWER CONNECTION

1. Connect the cord of the power adaptor to the DC IN JACK (#18) at the back of the SB3500.
2. Plug the power adaptor into a household wall socket. The unit is powered up and in standby mode when you see the display turn on and blink.

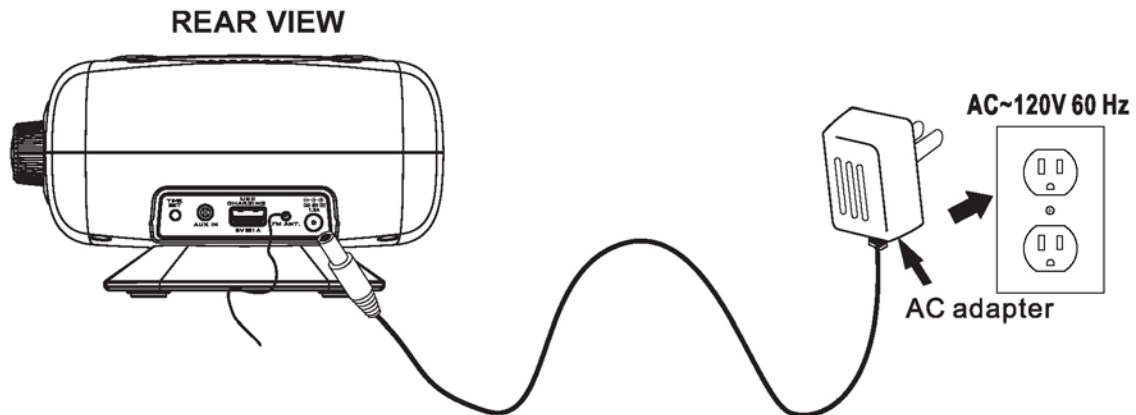

Battery Back-up system

- The radio is equipped with a battery back-up system. It requires 2 x AAA batteries (Not included).
- Open the BATTERY DOOR (#19) on the bottom of the unit. Insert the batteries into the battery compartment and make sure the positive and negative (+ or -) sides of the batteries are in contact with the corresponding terminals in the battery compartment. Replace the BATTERY DOOR (#19).

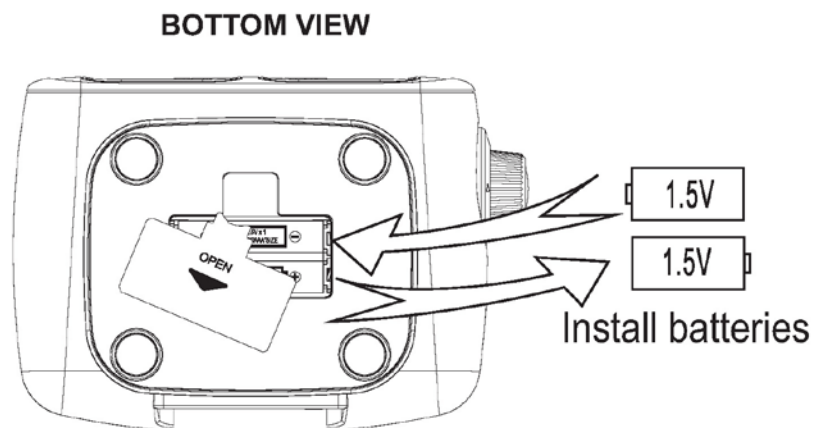

- If a power cut occurs, the unit automatically switches to the battery power supply and keeps the clock settings.
- When replacing the battery, do not disconnect the power adaptor. Otherwise, all clock and alarm settings will be lost.

Note: The unit will still operate without the batteries installed, but the time and alarm settings will be lost and have to be reset in the event of a power interruption or failure.

CAUTIONS:

1. Do not mix old and new batteries.
2. Only use good quality/name brand batteries.
3. Do not mix alkaline, standard (carbon-zinc) or rechargeable (nickel-cadmium) batteries.
4. If the unit is not going to be used for an extended period of time, please remove the batteries. Using old, leaking or cheaply made batteries can cause damage to the unit and may void the warranty.
5. Do not dispose of batteries in fire, batteries may explode or leak.
6. Batteries shall not be exposed to excessive heat such as sunshine, fire or the like.
7. Replace all the batteries at the same time, no matter exhausted or not, every 2 years at the same time to avoid possible battery leakage.
8. Do not try to recharge batteries not intended to be recharged; they can overheat, rupture and leak. (Follow battery manufacturer's directions).
9. Only an adult should replace the batteries.

CLOCK SETTING

The LCD DISPLAY (#13) will blink when the unit is plugged in for the first time and go into standby mode.

This unit features BATS – Bluetooth Automatic Time Set.

When any smartphone is connected through Bluetooth, the unit will automatically synchronize with the smartphone's clock. The unit may request authorization to access your smart phone.

Manually setting the Time

1. Press and hold the TIME SET BUTTON (#14) until the 12 Hr or 24 Hr blink on the LCD display (#13).
2. Repeatedly tap the - BUTTON (#5) or + BUTTON (#12) to select the 24-hour mode or 12-hour mode.
3. Tap the TIME SET BUTTON (#14) to confirm and the hour digits will blink.
4. Repeatedly tap the - BUTTON (#5) or + BUTTON (#12) to set the hour. Press and hold the buttons for fast advance/reverse setting.
Note: The PM icon on the bottom left corner of the LCD DISPLAY (#13) will light when the hour is set to PM and will be off when the hour is set to AM.
5. Press the TIME SET BUTTON (#14) to confirm and the minute digits will blink.
6. Repeatedly tap the - BUTTON (#5) or + BUTTON (#12) to set the minute. Press and hold the buttons for fast advance/reverse setting.
7. Tap the TIME SET BUTTON (#14) to confirm and complete the setting. The display will stop blinking.

Note:

- The unit will automatically save the settings and exit the time set mode if you do not tap the TIME SET BUTTON (#14) within 10 seconds.

ALARM OPERATION

The SB3500 features a dual alarm clock.

Setting the alarms:

1. Press and hold the ALARM 1 BUTTON (#8), the AL1 icon will light, and the hour of the alarm time will blink.
2. Tap the - BUTTON (#5) or + BUTTON (#12) to set the hour. Press and hold the buttons for fast advance/reverse setting.
3. Tap the ALARM 1 BUTTON (#8) to confirm the hour setting, the minutes digits will blink to prompt for input.
4. Tap the - BUTTON (#5) or + BUTTON (#12) to set the minute. Press and hold the button for fast reverse/advance setting.
5. Press the ALARM 1 BUTTON (#8) to confirm the minute setting, the alarm sound icons will show on the LCD DISPLAY (#13).
(bb – Alarm sound, F – FM radio, A – AM radio)
6. Repeatedly tap the - BUTTON (#5) or + BUTTON (#12) to select the wake up option (ALARM, FM Radio or AM Radio).
7. Press the ALARM 1 BUTTON (#8) to confirm and complete the alarm setting.
8. The ALARM 2 setting procedures are same as ALARM 1.

Wake to Radio (AM or FM)

- Make sure your radio station is set to the one you want to be woken up to. The unit will play the last radio station you listened to when the wake time is reached. The volume level will increase from low to high.
- The Radio will automatically turn on when the alarm time is reached. The corresponding AL1 or AL2 icon will blink.
- The alarm will sound for 60 minutes and then turn off automatically if the SNOOZE BUTTON (#7) is not pressed.
- To stop the radio sound immediately, tap the POWER  BUTTON (#1) or the corresponding alarm button.
- If you do not want the radio to turn on the following day, don't forget to tap the corresponding alarm button to disable the alarm.

Wake to Beeping Alarm

- The Beeping Alarm will automatically turn on when the alarm time is reached. The Beep sound level will increase from low to high.
- The corresponding AL1 or AL2 indicator will blink.
- The beep alarm will sound for 60 minutes and then turn off automatically if the SNOOZE BUTTON (#7) is not pressed.
- To stop the beep alarm sound immediately, tap the POWER  BUTTON (#1) or the corresponding alarm button.
- If you do not want the alarm to turn on the following day, don't forget to tap the corresponding alarm button to disable the alarm.

Turing the alarms ON or OFF

Tap the ALARM 1/ALARM 2 BUTTONS (#8/#9) once to enable the corresponding alarm. The alarm time will show on the display 5 seconds. Tap the ALARM 1/ALARM 2 BUTTONS (#8/#9) again to disable the corresponding alarm.

The corresponding AL1/AL2 icons will light when the alarm is enabled. The corresponding AL1/AL2 icons will turn off when the alarm is disabled.

Review the Alarm Setting

1. Press and hold the ALARM 1/ALARM 2 BUTTONS (#8/#9).
2. Tap the ALARM 1/ALARM 2 BUTTONS (#8/#9) repeatedly to check the corresponding alarm setting step by step.

Notes:

- For setting a one-day alarm, just set the desired alarm time one day before.
- The alarm will sound at the time set the day prior. After having switched off the alarm sound, tap the corresponding alarm button once to disable the alarm (the alarm icon will turn off).
- To set another one-day alarm, just repeat the above steps.



SNOOZE FUNCTION

When the alarm sounds, tap the SNOOZE BUTTON (#7) temporarily turn off the alarm and activate the snooze function, the alarm will stop and sound again 9 minutes later. If you tap the SNOOZE BUTTON (#7) again, the alarm will temporarily turn off again and sound again in 9 minutes and so on.

NOTES:

- The corresponding AL1 or AL2 icon light and the SNOOZE icon blink on the LCD DISPLAY (#13) during the snooze period.
- To cancel the snooze period and the alarm, press the POWER  BUTTON (#1).

RADIO OPERATION

1. Tap the POWER  BUTTON (#1) to turn on the unit and power indicator light.
2. Tap the MODE BUTTON (#3) repeatedly to select FM or AM radio mode.
3. The FM or AM icon will turn on and the frequency will show on the LCD display (#13).
4. Tap the - BUTTON (#5) or + BUTTON (#12) to adjust frequency.
5. Press and hold the - BUTTON (#5) or + BUTTON (#12) to search for the previous or next available FM station.
6. If the reception is poor, try Manual Tuning to fine-tune the station. Tap the - BUTTON (#5) or + BUTTON (#12) briefly to manually tune through the frequency band.
7. Adjust the VOLUME CONTROL (#11) to obtain the desired volume level.
8. When you have finished listening, press the POWER ON/OFF  BUTTON (#1) to turn the radio off.

Notes:

- In radio mode, the display will automatically switch back to showing the time after a few seconds.
- When listening to the radio, you can check the frequency of the station you are listening to by tapping the - BUTTON (#5) or + BUTTON (#12). The unit will automatically change back to the time after a few seconds.

To Set the Radio Presets

The unit allows you to store up to 10 FM stations and 10 AM stations to easily tune in to your favorite radio stations at any time.

1. Press the POWER ON/OFF  BUTTON (#1) to turn on the unit and the power indicator light.
2. Tap MODE BUTTON (#3) repeatedly to select FM or AM radio mode.
3. Tap the - BUTTON (#5) or + BUTTON (#12) to select the desired station.
4. Press and hold the RADIO PRESETS BUTTON (#10) until "P01" shows on the LCD DISPLAY (#13).
5. Tap the - BUTTON (#5) or + BUTTON (#12) to select a preset number (P01-P10).
6. Press the RADIO PRESETS BUTTON (#10) again to confirm the preset.
7. Repeat steps 3 through 6 to preset up to 10 stations.

Selecting a Preset Station

To select one of the preset stations already programmed, tap the RADIO PRESETS BUTTON (#10) repeatedly until you reach the desired preset number/radio station. Alternatively, press the RADIO PRESETS BUTTON (#10) once and then press the - BUTTON (#5) or + BUTTON (#12) to select a preset station.





TIPS FOR BEST RADIO RECEPTION

AM - The AM antenna is built inside the radio. If AM reception is weak, change the position of the unit until the internal antenna picks up the strongest signal.

FM - If FM reception is weak, fully extend the wire antenna and vary the position and location of the antenna until you find the strongest signal.

BLUETOOTH OPERATION

Pairing a Bluetooth Enabled Device with the SB3500

1. Tap the POWER  BUTTON (#1) to turn on the unit and the power indicator light.
2. Tap the MODE BUTTON (#2) repeatedly to select Bluetooth mode.
3. The Bluetooth icon  will turn on and flash on the LCD display (#13).
4. Turn on the Bluetooth function of your device and enable the search or scan function to find SB3500.
5. Select SB3500 from the device list when it appears on your device screen. If required, enter the pass code "0000" to pair (link) SB3500 with your device.
6. If you are pairing (linking) your computer to the speaker using Bluetooth, you may need to set the SB3500 as your computer's default sound device.
7. After pairing SB3500 with your Bluetooth device successfully, The Bluetooth icon  will light steadily.
8. If you want to pair the SB3500 with another Bluetooth device, press and hold the  PAIR BUTTON (#4), the Bluetooth icon  will flash. The unit will go into Pairing/Discoverable mode. Repeat steps 4 & 5.

Now you can play music from your Bluetooth device wirelessly to SB3500.

1. Selecting your favorite song, press Play/Pause Button on your Bluetooth device or PLAY/PAUSE  BUTTON (#4) on SB3500 to play or pause the Bluetooth device playback.
2. Tap the SKIP BACKWARD - BUTTON (#5) or SKIP FORWARD + BUTTON (#12) to select the Previous or Next track.
3. Slowly adjust both the volume controls of your SB3500 and your Bluetooth device until you reach a comfortable listening level.

Notes:

1. Refer to the manual of your cell phone, tablet PC, computer or other Bluetooth enabled devices for Bluetooth operation since it may vary from model to model.
2. If your Bluetooth enabled device does not support A2DP profile, it will not play the music through the speaker, even if paired (linked).
3. Remember to turn off the SB3500 when you have finished listening.
4. Don't forget to switch off the power of your external audio device as well.

AUX IN OPERATION

You can play other music sources (MP3 or other digital audio players) through the speakers of the unit by connecting the AUX IN JACK (#15) to your external player's audio out jack or headphone jack.

1. Plug one end of an audio cable (not included) into the AUX IN JACK (#15) and the other end of the cable to the headphone jack of your digital audio player.
2. Tap the POWER  BUTTON (#1) to turn on the unit and the power indicator light.
3. Tap the MODE BUTTON (#3) repeatedly to select AUX mode.
4. The AUX icon will show on the LCD Display (#13).
5. Turn on and start playing the external device you plugged into the AUX IN JACK (#15).
6. Slowly adjust both the volume controls of the unit and the external device until you reach a comfortable listening level.

Notes:

- If you connect the unit to the Line-Out Jack on your external device, you only need to adjust the volume control of your unit. If you connect to the Headphone Jack of your external device, you may need to adjust both the volume controls of your external device and the unit to obtain the desirable listening level.
- Remember to turn off the unit when you have finished listening. Don't forget to switch off the power of your external audio device as well.

SLEEP OPERATION

The sleep timer will automatically turn the unit off after a designated time has elapsed.

1. Tap the SLEEP BUTTON (#7) to enter sleep mode.
2. Repeatedly tap the SLEEP BUTTON (#7) to select the sleep timer 15 – 30 – 45 - 60 – OFF (in minutes). The unit will play for the selected length of time then turn off automatically.
3. To cancel the sleep timer, repeatedly tap the SLEEP BUTTON (#7) until the timer shows OFF.
4. To turn the unit "Off" before the selected length of time, press the POWER  BUTTON (#1) at any time.

Note: Tap the SLEEP BUTTON (#7) once to check the remaining sleep time.

DIMMER OPERATION

In standby mode, press and hold the DIMMER BUTTON (#7) repeatedly to select the brightness settings of the display (Low, Medium or High).

USB BATTERY CHARGING

CONNECTING A USB CORD (NOT INCLUDED) FOR CHARGING YOUR CELL PHONE (DC 5V \equiv 1 A)

1. Plug the standard end of the USB cable (not included) into the USB CHARGING PORT (#16) located on the back of the unit. Plug the other end of the cable into the device you wish to charge.
2. Observe the battery charge indicator on your device to make sure the charging process starts normally.
3. Unplug the cable when your device is fully charged.

WARNING!

- The USB port located on the back of the unit is designed for a smart phone or portable device battery charging only and does not support data transfer or connection to a computer.
- Don't connect the USB port of the unit to another USB charger. It may damage both units and void the warranty.

CARE AND MAINTENANCE

- Clean the radio with a soft damp cloth and let all parts dry completely after cleaning.
- Do not use any aggressive cleaners, brushes with nylon bristles, sharp or metallic cleaning utensils, knives, hard scrapers and the like. They could damage the surfaces of the radio.
- Do not immerse the radio in water and do not let water get into the housing of the radio.
- Unplug the power adaptor and clean the radio before storage.
- Always store the radio in a dry and clean place.

SPECIFICATIONS

Power:	AC Adaptor: Input AC 100-240V ~ Output: DC 5V \equiv 1.5A 
Backup battery:	2 x AAA batteries (not included)
USB Charging:	DC 5V \equiv 1A
Frequency Range:	FM 87.5 – 108 MHz AM 520 – 1710 KHz

TROUBLESHOOTING GUIDE

If you experience difficulties in the use of this clock radio, please check the following or call 1-800-777-5331 for Customer Service and support.

SYMPTOM	POSSIBLE CAUSE	POSSIBLE SOLUTION
Power does not come on	Power adaptor connection is unstable	Reconnect the adaptor
No sound	VOLUME control is turned down	Increase the Volume
Sound is distorted	Volume level is set too high.	Rotate the volume knob to select a comfortable level.
Noise or sound distorted on AM or FM broadcast	<ul style="list-style-type: none"> - Station not tuned properly - FM: Antenna is not extended - AM : Internal antenna is not positioned correctly 	<ul style="list-style-type: none"> - Retune Broadcast station - Fully extend the antenna - Reposition the unit until the best reception is obtained
No sound on Bluetooth	<ul style="list-style-type: none"> - The unit is not linked with the cell phone. - Unit placement out of range. - Volume set too low 	<ul style="list-style-type: none"> - Go through "Bluetooth Operations" process to link the speakers. - Relocate the unit within Bluetooth operating range. - Rotate the volume knob to turn the sound level up or increase sound on Bluetooth device
No charging from the USB port	The USB cable is damaged or not securely attached	Replace the USB cable or try to reconnect it again



At Spectra, environmental and social responsibility is a core value of our business. We are dedicated to continuous implementation of responsible initiatives with an aim to conserve and maintain the environment through responsible recycling.

Please visit us at <http://www.spectraintl.com/green.htm> for more information on Spectra's green initiatives or to find a recycler in your area.

The Bluetooth® word mark and logos are registered trademarks owned by Bluetooth SIG, Inc. and any use of such marks by Spectra Merchandising Intl, Inc. is under license. Other trademarks and trade names are those of their respective owners.

1 YEAR LIMITED WARRANTY AND SERVICE VALID IN THE U.S.A. ONLY

SPECTRA MERCHANDISING INTERNATIONAL, INC. warrants this unit to be free from defective materials or factory workmanship for a period of 1 year from the date of original customer purchase and provided the product is utilized within the U.S.A. This warranty is not assignable or transferable. Our obligation under this warranty is the repair or replacement of the defective unit or any part thereof, except batteries, when it is returned to the SPECTRA Service Department, accompanied by proof of the date of original consumer purchase, such as a duplicate copy of a sales receipt.

You must pay all shipping charges required to ship the product to SPECTRA for warranty service. If the product is repaired or replaced under warranty, the return charges will be at SPECTRA's expense. There are no other express warranties other than those stated herein.

This warranty is valid only in accordance with the conditions set forth below:

1. The warranty applies to the SPECTRA product only while:
 - a. It remains in the possession of the original purchaser and proof of purchase is demonstrated.
 - b. It has not been subjected to accident, misuse, abuse, improper service, usage outside the descriptions and warnings covered within the user manual or non-SPECTRA approved modifications.
 - c. Claims are made within the warranty period.
2. This warranty does not cover damage or equipment failure caused by electrical wiring not in compliance with electrical codes or SPECTRA user manual specifications, or failure to provide reasonable care and necessary maintenance as outlined in the user manual.
3. Warranty of all SPECTRA products applies to residential use only and is void when products are used in nonresidential environment or installed outside the United States.

This warranty gives you specific legal rights, and you may also have other rights which vary from state to state. TO OBTAIN SERVICE please remove all batteries (if any) and pack the unit carefully and send it freight prepaid to SPECTRA at the address shown below. IF THE UNIT IS RETURNED WITHIN THE WARRANTY PERIOD shown above, please include a proof of purchase (dated cash register receipt) so that we may establish your eligibility for warranty service and repair of the unit without cost. Also include a note with a description explaining how the unit is defective. A customer service representative may need to contact you regarding the status of your repair, so please include your name, address, phone number and email address to expedite the process.

IF THE UNIT IS OUTSIDE THE WARRANTY PERIOD, please include a check for **\$55.00** to cover the cost of repair, handling and return postage. All out of warranty returns must be sent prepaid.

It is recommended that you contact SPECTRA first at 1-800-777-5331 or by email at custserv@spectraintl.com for updated information on the unit requiring service. In some cases, the model you have may be discontinued, and SPECTRA reserves the right to offer alternative options for repair or replacement.

SPECTRA MERCHANDISING INTERNATIONAL, INC.
4230 North Normandy Avenue,
Chicago, IL60634, USA. 1-800-777-5331

To register your product, visit the link on the website below to enter your information.
<http://www.spectraintl.com/wform.htm>

1123

Printed in China
(SB3500BKB, SB3500CRB, SB3500RGB, SB3500BLB, B3500TEB)