

User Manual

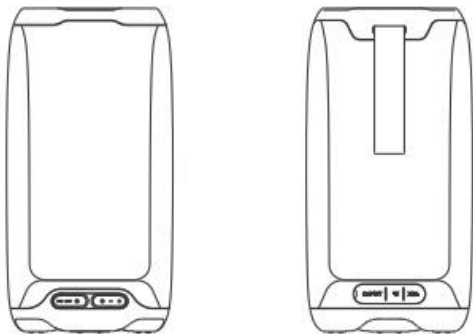

S25

Product User Manual

Packing List

Host * 1 Audio cable * 1 Instructions * 1
Charging cable * 1 Certificate of conformity * 1

Product Parameters

Audio parameters

Product Name: Karaoke sound system
Product model: S25
Sound channel system; Monophonic channel
Bluetooth module: 5.3+EDR
Transmission distance: 10 m
Rated input: 5V-1A (fast charging not supported)
Rated power: 7.4W
Product weight: 0.98kg

Battery capacity; 3600 mAh
Charging method: Type-c
Charging time: approximately 2 hours
Battery life: approximately 24 hours
Playback duration: 3.5-4 hours
Horn size; 66mm
Product size: 115 * 105 * 215mm

Audio parameters

Microphone parameters

Frequency range: 2.4GHz
Channel System: Mono
Sampling rate: 48KHZ
Rated input: 5V -1A
Voice wake-up
Xiao An Tong Xue

Battery capacity: 3.7V/800mAh
Charging method: Type-c
Charging time: approximately 2 hours
Battery life: approximately 12 hours

Product Appearance Description

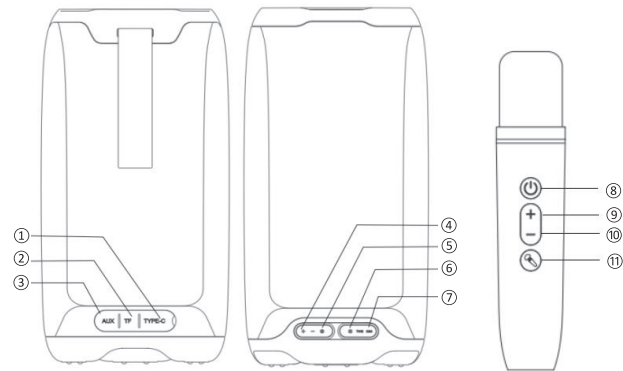

Audio:

1. Type-c charging port;
2. TF card;
3. AUX input;
4. Short press the volume up, long press one song;
5. Short press to decrease the volume, long press the previous song;
6. Short press the light mode to switch, long press to enter TWS, and the green light will be on for a long time;
7. Long press to turn on/off, short press to play, pause, and the red light flashes when charging, while the red light remains on when fully charged;

Microphone:

8. Long press to turn on/off, short press to mute, double-click to change the color of the colored light; When charging, the red light flashes and remains on when fully charged;
9. Short press Reverb Plus
10. Short press to reduce reverberation;
11. Long press to turn reverb on/off, short press to change sound

After sales service description

Dear user, thank you very much for using our product. In order to effectively protect your rights and interests, it is clear that the distribution agents and companies should bear the responsibility and obligation of product repair, replacement, and return (hereinafter referred to as the "three guarantees"). Please read the following information

1. The "Product Warranty Card" is a necessary voucher for our company to provide free after-sales service for the product during the warranty period
2. According to the principle of "whoever sells is responsible for the three guarantees", if there are quality issues with the product, please contact the dealer with the "Product Warranty Card". The dealer will provide service to the customer, and our company will provide service support to the dealer;
3. Our company promises that customers who have quality issues within seven days from the date of sale (the date shall be based on the valid invoice date, the same below) can return, replace, or repair them now; If there are quality issues within 8-15 days from the date of sale, customers can choose to replace and repair them; If there are quality issues within one year from the date of sale, customers can repair them free of charge; If there are quality issues with the product beyond the warranty period, customers can enjoy lifelong repair (each after-sales service point only charges for component materials): Please fill out the "Product Warranty Card" carefully with the dealer when purchasing

4. The following situations do not qualify for the three guarantees service:

- (1) Exceeding the three guarantees period
- (2) Damage caused by failure to use, repair, or store according to the product manual
- (3) Damage caused by disassembly by repairers who are not responsible for the three guarantees
- (4) The content on the Product Warranty Card does not match or is altered with the physical product identification
- (5) Damage caused by force majeure

Common problem handling

- 1.If the indicator light does not light up after turning on, please check if the audio power is sufficient, or connect the audio to a 5V/1A power supply for charging. The charging time is approximately 3-4 hours
2. There is no sound from the microphone. It may be due to the power not being turned on, the mode being incorrect, or the volume not being adjusted. Please adjust the microphone volume properly
3. If there is no reverberation in the audio system, it may be that the reverberation switch has been turned off. Please turn on the reverberation switch. 4. If there is noise in the microphone, it may be due to environmental noise, signal interference, or the microphone being too close to the speaker. Please readjust the direction of the microphone
- If Bluetooth playback is interrupted, it may be because the Bluetooth distance is too far, or there is an obstacle between the phone and the amplifier, which affects signal transmission. Please approach the connected phone and avoid obstacles
6. If Bluetooth cannot be connected, it may be due to being too far away, having obstacles, or being connected by other phones. Please approach the phone to avoid obstacles and disconnect the phone
7. If it is impossible to charge, check whether the charger is normal and whether the red indicator light of the charging port lights up when the audio is charging

Tips

This product is not sold with a power adapter. If a power adapter is used for power supply, a power adapter that has obtained CCC certification and meets the standard requirements should be purchased. The battery should not be exposed to environments such as sunlight, fire, or similar overheating. If the battery is not replaced properly, there is a risk of explosion, and it can only be replaced with the same type of battery

Product model: S25

Purchase date:

Agent:

Invoice date:

Phone:

Customer Name:

Postal Code:

QUALIFIED CERTIFICATE

MODEL: _____
CHECKER: _____
DATE: _____



FCC Warning:

This equipment has been tested and found to comply with the limits for a Class B digital device, pursuant to part 15 of the FCC Rules. These limits are designed to provide reasonable protection against harmful interference in a residential installation. This equipment generates, uses and can radiate radio frequency energy and, if not installed and used in accordance with the instructions, may cause harmful interference to radio communications. However, there is no guarantee that interference will not occur in a particular installation. If this equipment does cause harmful interference to radio or television reception, which can be determined by turning the equipment off and on, the user is encouraged to try to correct the interference by one or more of the following measures:

- Reorient or relocate the receiving antenna.
- Increase the separation between the equipment and receiver.
- Connect the equipment into an outlet on a circuit different from that to which the receiver is connected.
- Consult the dealer or an experienced radio/TV technician for help.

Caution: Any changes or modifications to this device not explicitly approved by manufacturer could void your authority to operate this equipment.

This device complies with part 15 of the FCC Rules. Operation is subject to the following two conditions:

(1) This device may not cause harmful interference, and (2) this device must accept any interference received, including interference that may cause undesired operation.

This equipment complies with FCC radiation exposure limits set forth for an uncontrolled environment. This equipment should be installed and operated with minimum distance 0cm between the radiator and your body.