

S21 Module Specification

Rev. 0.5

Linkplay Confidential

Table of contents

S21 Module Specification.....	1
Rev. 0.5.....	1
1 Module overview.....	3
1.1 MCU.....	3
1.2 Wi-Fi.....	3
1.3 Bluetooth.....	3
2 Hardware.....	3
2.1 Test Items.....	4
2.2 Description.....	4
2.3 Block Diagram.....	4
2.4 Pin Definitions.....	5
2.5 Pin Description.....	6
2.6 Strapping Pins.....	7
3 Electrical Characteristics.....	8
3.1 Absolute Maximum Ratings.....	8
3.2 Recommended Operating Conditions.....	9
3.3 DC Characteristics(3.3V,25°C).....	9
3.4 Current Consumption Characteristics.....	9
3.5 Wi-Fi Radio.....	10
3.5.1 Wi-Fi RF Standards.....	10
4 Module Size.....	11
5 FCC Warning.....	11
6 Revision History.....	12

1 Module overview

1.1 MCU

- S21 embedded 32-bit RISC-V single-core processor, up to 160MHz
- 384KB ROM
- 400KB SRAM (16 KB for cache)
- 8KB SRAM in RTC

1.2 Wi-Fi

- IEEE 802.11 b/g/n compliant
- Frequency range of operating channel:2412~2484MHz
- Supports 20MHz,40MHz bandwidth in 2.4GHz band
- 1T1R mode with data rate up to 150Mbps
- Wi-Fi Multimedia (WMM)
- TX/RX A-MPDU, TX/RX A-MSDU
- Immediate Block ACK
- Fragmentation and defragmentation
- Transmit opportunity (TXOP)
- Automatic Beacon monitoring (hardware TSF)
- 4×virtual Wi-Fi interfaces
- Simultaneous support for Infrastructure BSS in Station mode,SoftAP mode,Station + SoftAP mode,and promiscuous mode

(Note that when S21 scans in Station mode,the SoftAP channel will change along with the station channel)

- 802.11mc FTM

1.3 Bluetooth

- Bluetooth LE: Bluetooth 5, Bluetooth mesh
- Speed:125Kbps,500Kbps,1Mbps,2Mbps
- Advertising extensions
- Multiple advertisement sets
- Channel selection algorithm #2

2 Hardware

Interfaces: GPIO, SPI, UART, I2C, I2S, remote control peripheral, LED PWM controller, general DMA controller, TWAI controller (compatible with ISO11898-1), USB Serial/JTAG controller, temperature sensor, SAR ADC

40MHz crystal oscillator

4MB SPI flash

Operating voltage/Power supply: 3.0~3.6V

Operating ambient temperature:

- 85°C version module: -40~85°C
- 105°C version module: -40~105°C

• Dimensions: See Table 1

2.1 Test Items

• HTOL/HTSL/uHAST/TCT/ESD/Latch-up

2.2 Description

The S21 is a universal Wi-Fi and Bluetooth LE module. Rich peripherals and high performance make this module an ideal choice for smart home, industrial automation, healthcare, consumer electronics and more.

S21 adds an antenna switch, not connecting the external antenna button means that the wire is directly connected to the PCB antenna. When the external antenna is connected, the BACK-END PCB antenna is disconnected.

The ordering information for modules is as follows:

Module	Chip embedded	Module dimensions(mm)
S21	ESP32-C3FH4AZ	13.2x18.3x2.4

2.3 Block Diagram

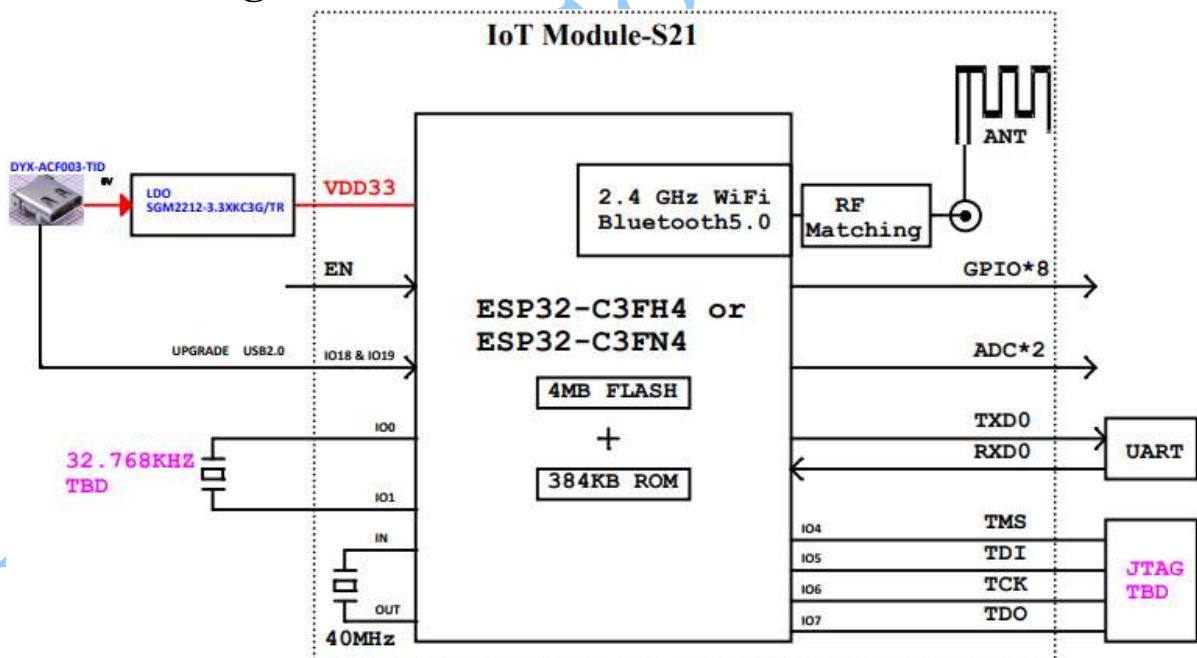

2.4 Pin Definitions

The pin diagram below shows the approximate location of pins on the module.

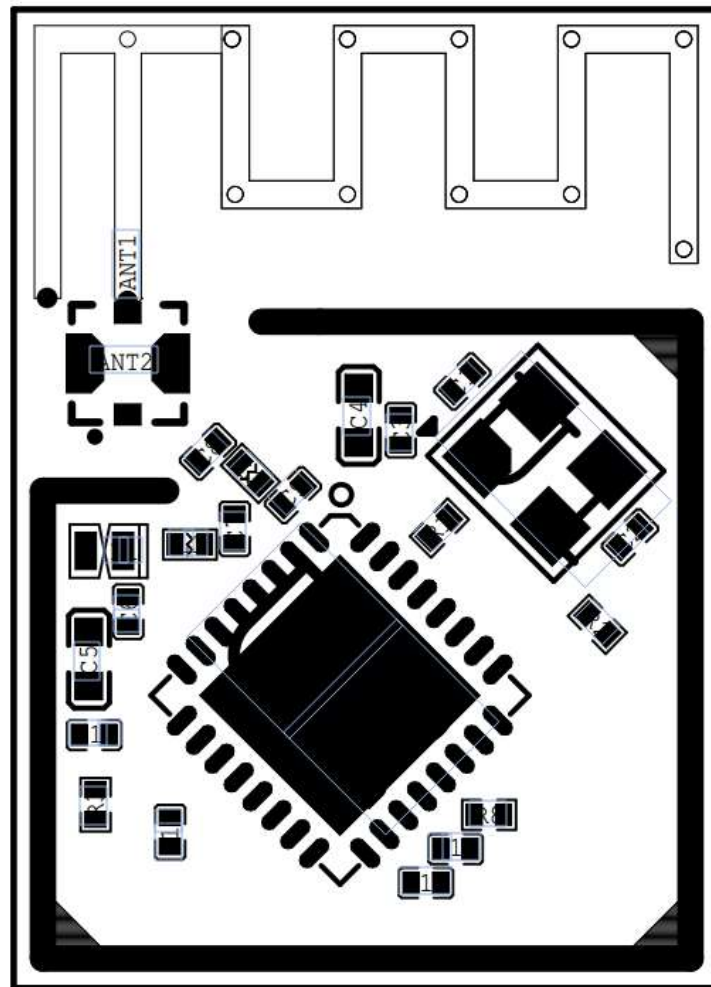

TOP VIEW

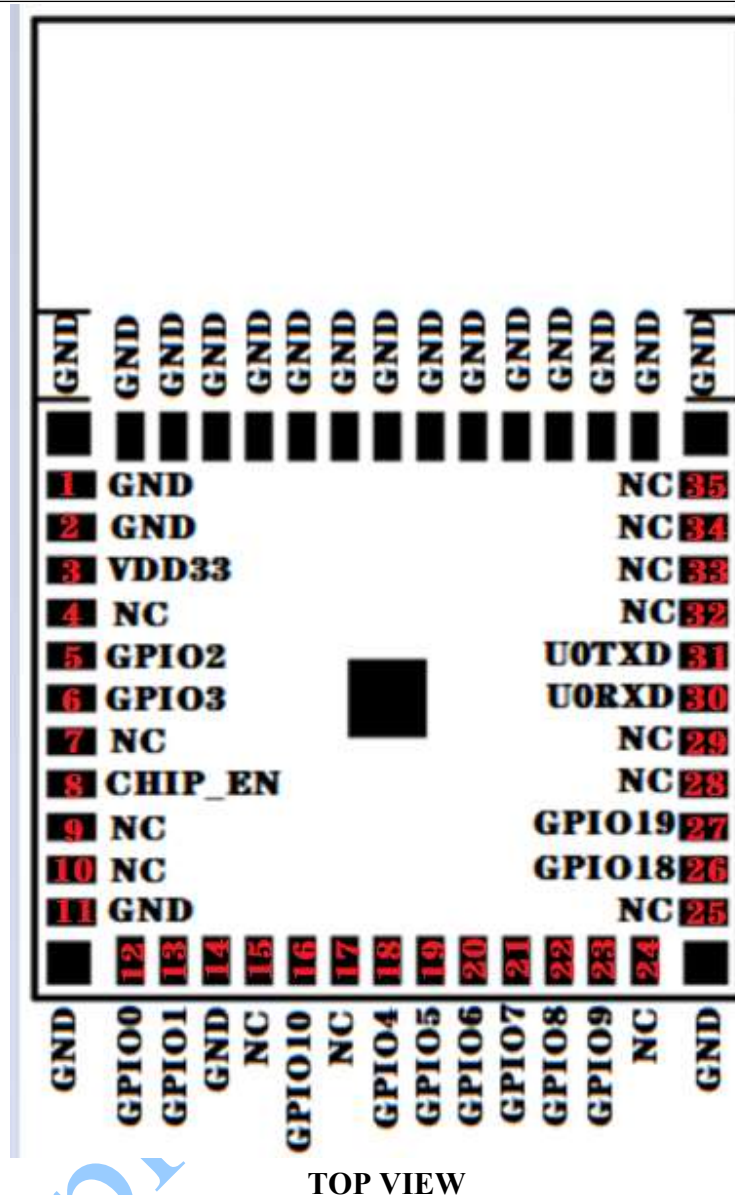

2.5 Pin Description

The module has 36 pins. Pin definitions are shown in the following table.

Name	No.	Type	Function
GND	1,2	Power Ground	Ground
3V3	3	Power Input	Power supply
IO2	5	Bidirectional	GPIO2,ADC1_CH2,FSPIQ
IO3	6	Bidirectional	GPIO3,ADC1_CH3
EN	8	Analog Input	High: On, enables the chip Low: Off, the chip powers off Note: Do not; leave the EN pin floating

IO0	12	Bidirectional	GPIO0,ADC1_CH0,XTAL_32K_P
IO1	13	Bidirectional	GPIO1,ADC1_CH0,XTAL_32K_N
GND	14	Power Ground	Ground
IO10	16	Bidirectional	GPIO10,FSPICS0
IO4	18	Bidirectional	GPIO4,ADC1_CH4,FSPIHD,MTMS
IO5	19	Bidirectional	GPIO5,ADC2_CH0,FSPIWP,MTD
IO6	20	Bidirectional	GPIO6,FSPICLK,MTCK
IO7	21	Bidirectional	GPIO7,FSPID,MTDO
IO8	22	Bidirectional	GPIO8
IO9	23	Bidirectional	GPIO9
IO18	26	Bidirectional	GPIO18,USB_D-
IO19	27	Bidirectional	GPIO19,USB_D+
RXD0	30	Bidirectional	GPIO20,U0RXD
TXD0	31	Bidirectional	GPIO21,U0TXD

2.6 Strapping Pins

S21 has four strapping pins:

- GPIO2
- GPIO8
- GPIO9

Software can read the values of GPIO2, GPIO8 and GPIO9 from GPIO_STRAPPING field in GPIO_STRAP_REG register.

During the chip's system reset, the latches of the strapping pins sample the voltage level as strapping bits of "0" or "1", and hold these bits until the chip is powered down or shut down.

Types of system reset include:

- power-on-reset
- RTC watchdog reset
- brownout reset
- analog super watchdog reset
- crystal clock glitch detection reset

By default, GPIO9 is connected to the internal pull-up resistor. If GPIO9 is not connected or connected to an external high-impedance circuit, the latched bit value will be "1"

To change the strapping bit values, you can apply the external pull-down/pull-up resistances, or use the host MCU's GPIOs to control the voltage level of these pins when powering on S21.

After reset, the strapping pins work as normal-function pins.

See the table below for more information on the startup mode configuration of the bundling pins.

Booting Mode			
Pin	Default	SPI Boot	Download Boot
GPIO2	N/A	1	1
GPIO8	N/A	Don't care	0

GPIO9	Internal pull-up	I/O/T	1
Enabling/Disabling ROM Code Print During Booting			
Pin	Default	Functionality	
GPIO8	N/A	When the value of effuse field EFFUSE_UART_PRINT_CONTROL is 0(default),print is enabled and not controlled by GPIO8. 1,if GPIO8 is 0,print is enabled; if GPIO8is1,it is disabled. 2,if GPIO8 is 0,print is disabled; if GPIO8is1,it is enabled. 3,print is disabled and not controlled by GPIO8.	

(The strapping combination of GPIO8=0 and GPIO9=0 is invalid and will trigger unexpected behavior.)

The figure below shows the Settings and hold times for tying pins before and after the CHIP_EN signal gets high. The details of the parameters are listed below

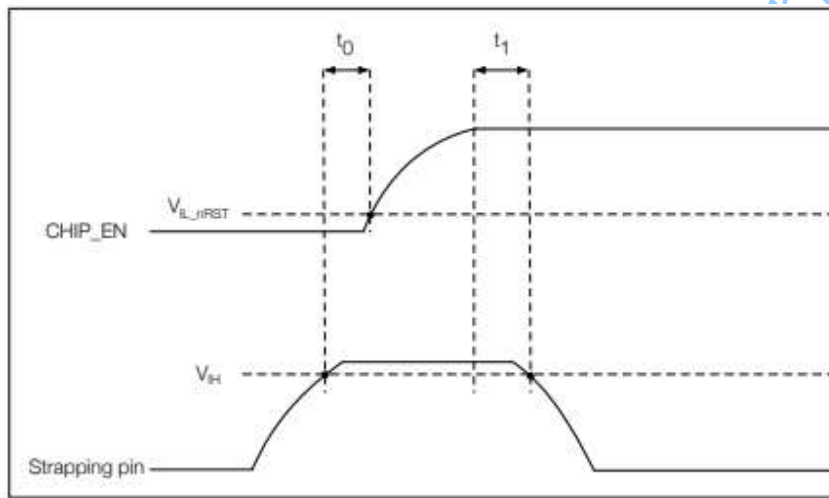

Parameter	Description	Functionality
T0	Setup time before CHIP EN goes from low to high	0
T1	Hold time after CHIP EN goes high	3

3 Electrical Characteristics

3.1 Absolute Maximum Ratings

Stresses above those listed in Absolute Maximum Ratings may cause permanent damage to the device. These are stress ratings only and functional operation of the device at these or any other conditions beyond those indicated under Recommended Operating Conditions is not implied. Exposure to absolute-maximum-rated conditions for extended periods may affect device reliability.

Symbol	Parameter	Min	Max	Unit
VDD33	Power supply voltage	-0.3	3.6	V
T _{STORE}	Storage temperature	-40	105	°C

3.2 Recommended Operating Conditions

Symbol	Parameter	Min	Typ	Max	Unit
VDD33	Power supply voltage	-0.3	3.3	3.6	V
I _{VDD}	Current delivered by external power supply		-	-	A
T _A	Ambient temperature	-40	-	85	°C
				105	
Humidity	Humidity condition	-	-	85	%RH

3.3 DC Characteristics(3.3V,25°C)

Symbol	Parameter	Min	Typ	Max	Unit
C _{IN}	Pin capacitance	-	2	-	pF
V _{IH}	High-level input voltage	0.75xVDD	-	VDD+0.3	V
V _{IL}	Low-level input voltage	-0.3	-	0.25xVDD	V
I _{IH}	High-level input current	-	-	50	nA
I _{IL}	Low-level input current	-	-	50	nA
V _{OH} ²	High-level output voltage	0.8xVDD	-	-	V
V _{OL} ²	Low-level output voltage	-	-	-	V
I _{OH}	High-level source current(VDD1=3.3V, VOH>=2.64V,PAD_DRIVER=3)	-	40	-	mA
I _{OL}	Low-level sink current(VDD1=3.3V, VOL=0.495V,PAD_DRIVER=3)	-	28	-	mA
R _{PU}	Pull-up resistor	-	45	-	kΩ
R _{PD}	Pull-down resistor	-	45	-	kΩ
V _{IH_nRST}	Chip reset release voltage	0.75xVDD1	-	VDD+0.3	V
V _{IL_nRST}	Chip reset voltage	-0.3	-	0.25xVDD	V

(VDD is the I/O voltage for a particular power domain of pins.)

(VOH and VOL are measured using high-impedance load.)

3.4 Current Consumption Characteristics

With the use of advanced power-management technologies, the module can switch between different power modes.

Work mode	Description		Peak (mA)
Active (RF working)	TX	-802.11b, 1 Mbps, @20.5 dBm	345
		802.11g, 54 Mbps, @18 dBm	285
		802.11n, HT20, MCS 7, @17.5 dBm	280
		802.11n, HT40, MCS 7, @17 dBm	280
	RX	802.11b/g/n, HT20	82
		802.11n, HT40	84

(The current consumption measurements are taken with a 3.3 V supply at 25 °C of ambient temperature at the RF port. All transmitters' measurements are based on a 100% duty cycle.)

(The current consumption figures for in RX mode are for cases when the peripherals are disabled and the CPU idle.)

Work mode	Description		Peak (mA)	Unit
Modem-sleep	The CPU is Powered on	160MHz	20	mA
		80MHz	15	mA
Light-sleep	-		130	μ A
Deep-sleep	RTC timer + RTC memory		5	μ A
Power off	CHIP_PU is set to low level, the chip is powered off		1	μ A

(The current consumption figures in Modem-sleep mode are for cases where the CPU is powered on and the cache idle.)

(When Wi-Fi is enabled, the chip may switch between Active and Modem-sleep modes. Therefore, current consumption changes accordingly.)

(In practice, software can adjust CPU's frequency according to CPU load to reduce current consumption.)

3.5 Wi-Fi Radio

3.5.1 Wi-Fi RF Standards

Name		Description
Center frequency range of operating channel		2412 ~ 2484 MHz
Wi-Fi wireless standard		IEEE 802.11b/g/n
Data rate	20 MHz	11b: 1, 2, 5.5 and 11 Mbps 11g: 6, 9, 12, 18, 24, 36, 48, 54 Mbps 11n: MCS0-7, 72.2 Mbps (Max)
	40 MHz	11n: MCS0-7, 150 Mbps (Max)
Antenna type		PCB antenna, IPEX antenna

(Device should operate in the center frequency range allocated by regional regulatory authorities.)

(Target center frequency range is configurable by software.)

4 Module Size

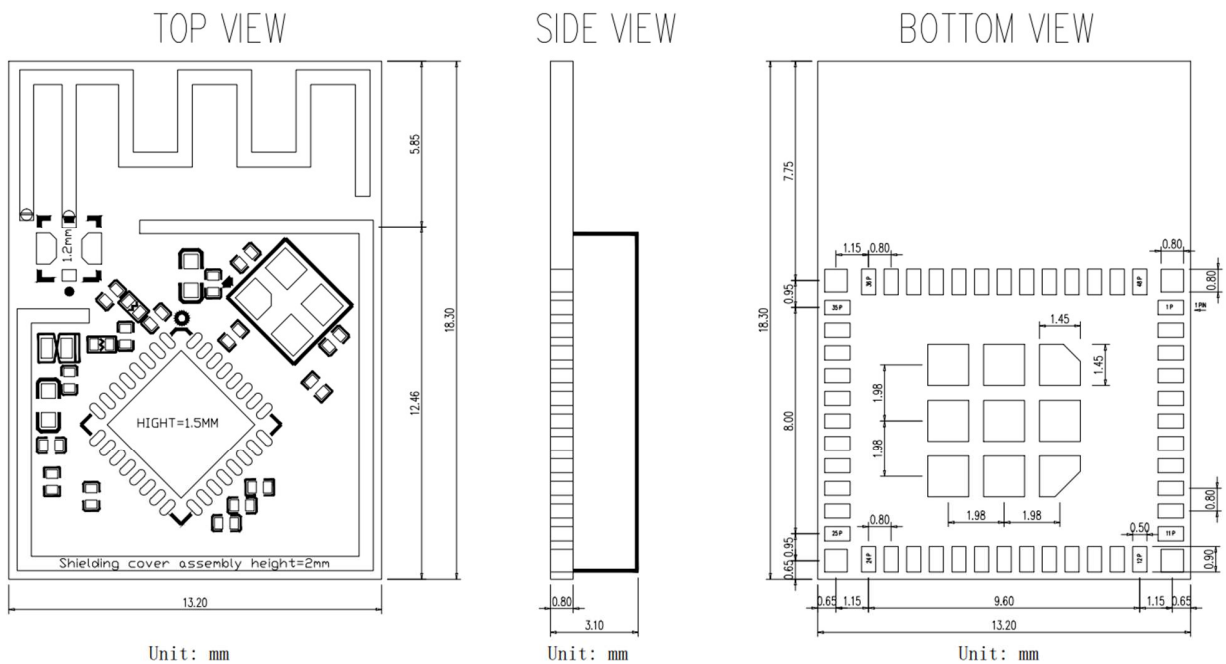

5 FCC Warning

Federal Communication Commission (FCC) Radiation Exposure Statement

When using the product, maintain a distance of 20cm from the body to ensure compliance with RF exposure requirements.

FCC statements:

This device complies with part 15 of the FCC rules. Operation is subject to the following two conditions:

- (1) this device may not cause harmful interference, and
- (2) this device must accept any interference received, including interference that may cause undesired operation.

NOTE: The manufacturer is not responsible for any radio or TV interference caused by unauthorized modifications or changes to this equipment. Such modifications or changes could void the user's authority to operate the equipment.

NOTE: This equipment has been tested and found to comply with the limits for a Class B digital device, pursuant to part 15 of the FCC Rules. These limits are designed to provide reasonable protection against harmful interference in a residential installation. This equipment generates uses and can radiate radio frequency energy and, if not installed and used in accordance with the instructions, may cause harmful interference to radio communications. However, there is no guarantee that interference will not occur in a particular installation. If this equipment does cause harmful interference to radio or television reception, which can be determined by turning the

equipment off and on, the user is encouraged to try to correct the interference by one or more of the following measures:

- Reorient or relocate the receiving antenna.
- Increase the separation between the equipment and receiver.
- Connect the equipment into an outlet on a circuit different from that to which the receiver is connected.
- Consult the dealer or an experienced radio/TV technician for help.

This device is intended only for OEM integrators under the following conditions:

1. The antenna must be installed such that 20 cm is maintained between the antenna and users.
2. The transmitter module may not be co-located with any other transmitter or antenna. As long as the two conditions above are met, additional transmitter testing will not be required. However, the OEM integrator is still responsible for testing their end-product for any additional compliance requirements required for the installed module.

Important Note:

In the event that these conditions cannot be met (for example certain laptop configurations or co-location with another transmitter), then the Federal Communications Commission of the U.S. Government (FCC) and the Canadian Government authorizations are no longer considered valid and the FCC ID and IC ID cannot be used on the final product. In these circumstances, the OEM integrator shall be responsible for re-evaluating the end-product (including the transmitter) and obtaining a separate FCC and IC authorization in the U.S. and Canada.

OEM Integrators - End Product Labeling Considerations:

This transmitter module is authorized only for use in device where the antenna may be installed such that 20 cm may be maintained between the antenna and users. The final end product must be labeled in a visible area with the following: “Contains, FCC ID: 2BABF-S21. The grantee’s FCC ID can be used only when all FCC compliance requirements are met.

OEM Integrators - End Product Manual Provided to the End User:

The OEM integrator shall not provide information to the end user regarding how to install or remove this RF module in end product user manual. The end user manual must include all required regulatory information and warnings as outlined in this document.

6 Revision History

Revision	Date	Originator	Comments
0.1	2021/09/08	Ping zhang	Initial Release
0.2	2022/01/11	Ping zhang	Second issue
0.3	2022/05/25	Ping zhang	Update module specifications

0.4	2022/07/27	Ya hui Zhou	Update module size
0.5	2023/06/05	Shengwei Yang	Add “FCC Warning”

Linkplay Confidential