

深圳旭航通讯科技有限公司

Shenzhen Xuhang Communication

Technology Co., Ltd

规格承认书

Antenna manufacturer	Shenzhen Xuhang Communication Technology Co., Ltd
Manufacturer's address	213-214, 2nd Floor, Building 1, Chenghede Industrial Park, No. 23 Huawang Road, Tongsheng Community, Dalang Street, Longhua District, Shenzhen
Name of the supplier	WIFI ANT
Antenna type	XH220075 (L=100mm)

客户确认

检验	审核	批准

供方确认

设计	射频	审核	批准

日期：2022 年 08 月 13 日

电性测试报告

TEST REPORTS

频率 Frequency	WIFI(2400~2500MHz)
阻抗 Impedance	50 Ohm Nominal
驻波比 V.S.W.R	≤ 2.0
辐射 Radiation	Omni-directional
增益 Gain(Peak)	2dBi
极化方式 Polarization	Linear,Vertical
功率 Admitted Power	1W
连接器 Connector	I-PEX I
Physical Properties	
天线材质 Antenna Material	PCB
线材类型 Cable Type	O.D.1.13mm
工作温度 Operating Temp.	-10-+60°C
存储温度 Storage Temp.	-10-+70°C
线材颜色 Cable Color	Black

匹配电路 Matching Circuits

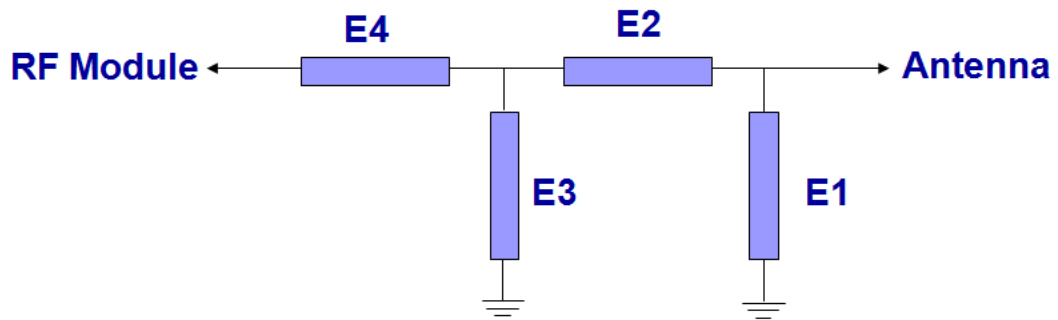

匹配电路 Matching Circuits

Element	Value	Vender
E1(0402)		
E2(0402)	0Ω	
E3(0402)		
E4(0402)	0Ω	

The original matching circuit is unchanged

Radiation Pattern

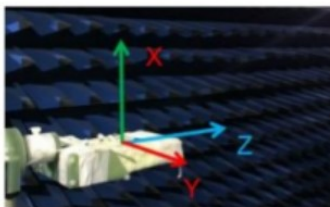
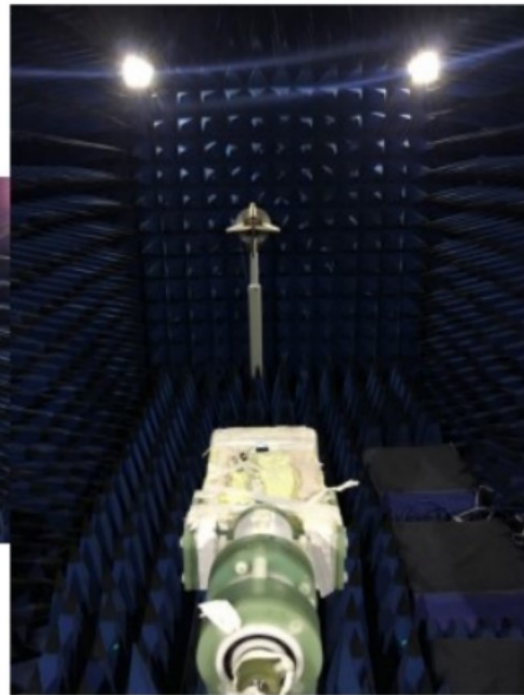
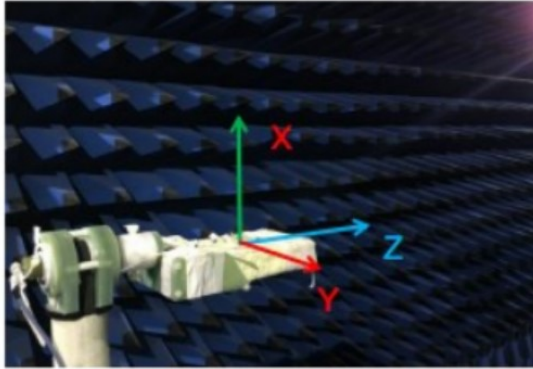

2400 MHz
ANT

H面: XY
E1面: XZ
E2面: YZ

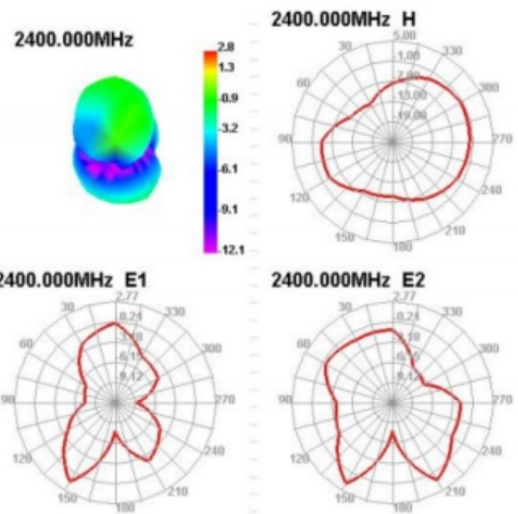

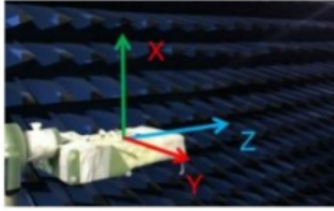

H面: XY
E1面: XZ
E2面: YZ

2450 MHz
ANT

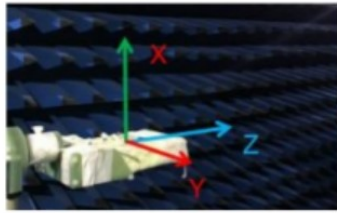
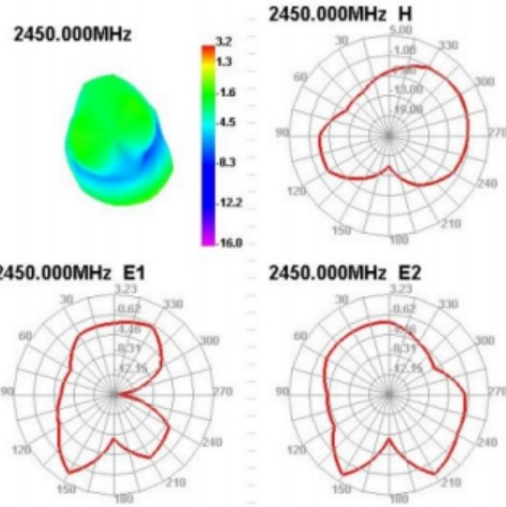

H面: XY
E1面: XZ
E2面: YZ

2500 MHz
ANT

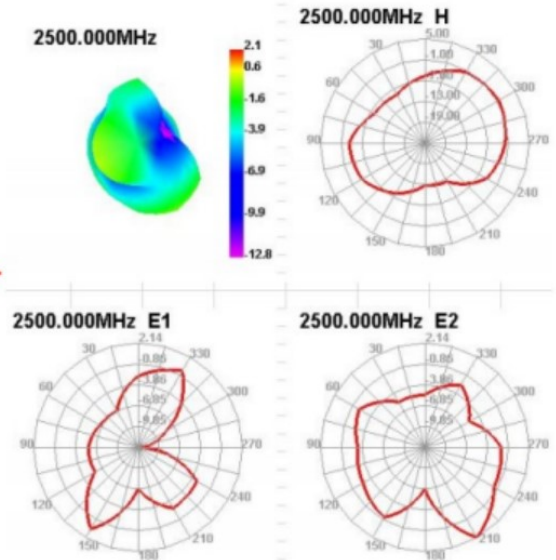

Gain table of Antenna

Frequency (MHz)	ANT	
	Efficiency (%)	Peak Gain (dBi)
2400	43.1	1.77
2410	44.98	1.33
2420	43.57	1.17
2430	44.18	1.34
2440	44.55	1.56
2450	45.83	2.00
2460	46.48	1.69
2470	46.31	1.42
2480	45.7	1.03
2490	44.19	1.29
2500	41.61	1.14

版次	修改内容	设计	审核	修改日期
A0	初版发行			

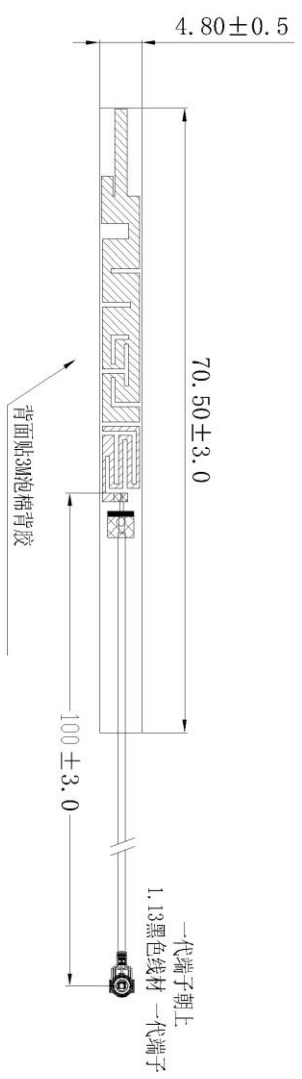

数量	名称	规格	单位	数量
2	同轴线	黑色	1.13	1
1	PCB	绿色		1

深圳旭航通讯科技有限公司

一般公差:	立项号: XH220075	日期: 2022.08.13
X	版本号: RA	结构:
.X	材质:	射频:
.XX	颜色:	批准:
.XXX	比例: 1:1	单位: mm
ANGULAR	$\Delta \pm 0.5^*$	比例: 1:1

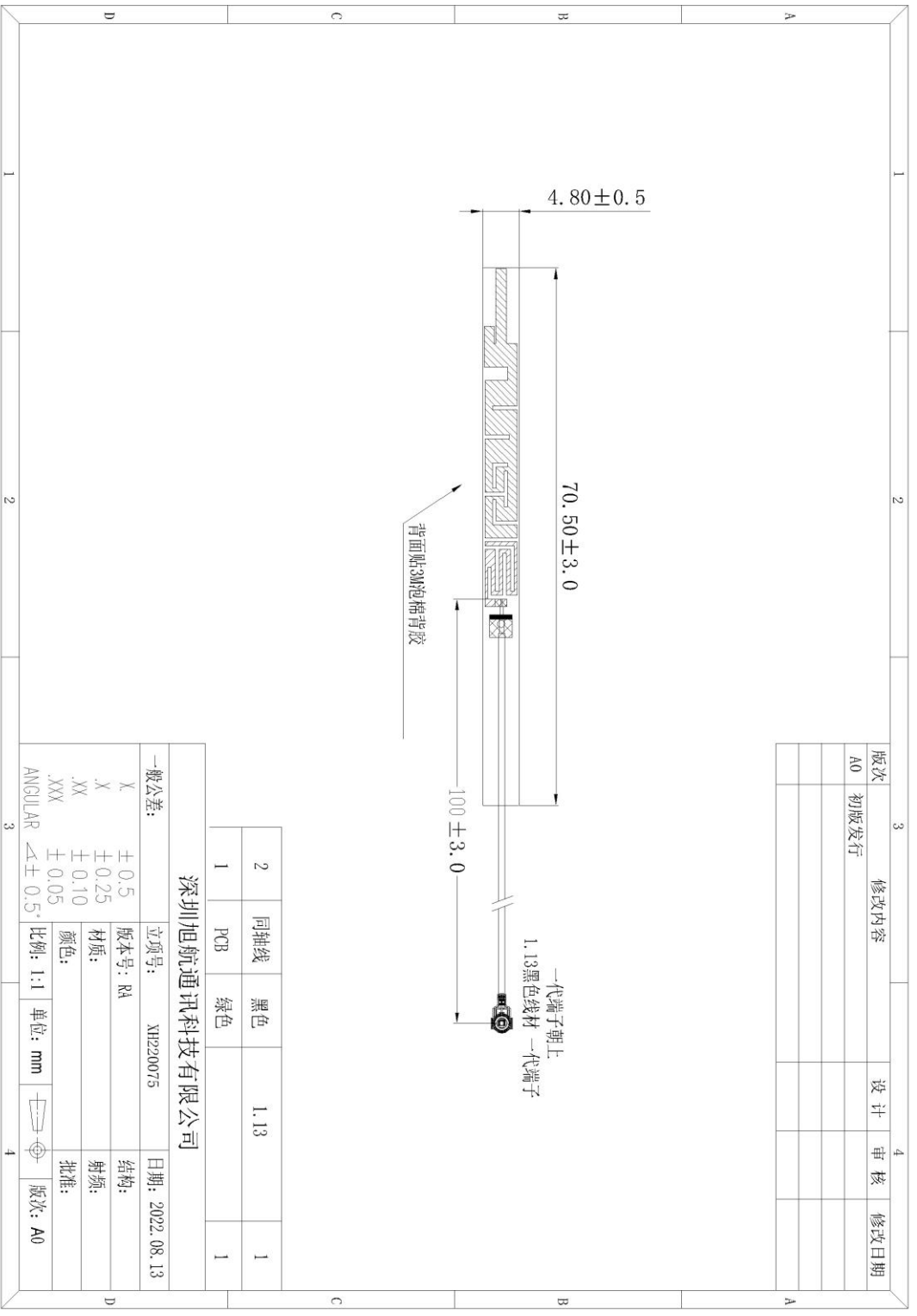

Antenna assembly position

As shown in the figure: the antenna is assembled at the arrow:

